

Confidential

1. Introduction

The TDx51xx-series are single-chip PLL-transmitter-ICs designed for RKE and remote controls along with any other ISM-applications.

During EMI-tests the application is subject to a strong radiated electromagnetic field of variable frequency. For certain applications (especially for automotive) the design has to withstand a very high field strength. This application note shows some ways for improvement of the EMI-performance.

2. Compact Layout

A good layout is very important. A groundplane should be used below all components. PCB-traces should be as short as possible, especially at the crystal oscillator.

3. Filtering

A series inductance (100-220nH) placed directly at pin10 (COSC) acts as a high impedance at high frequencies of the interferer. So the interference at pin10 will be reduced.

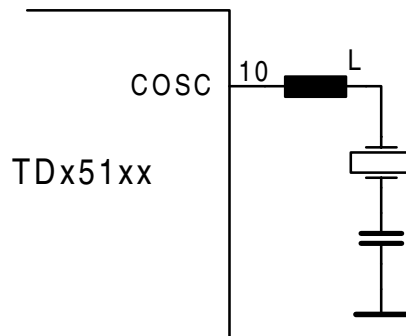

Inductor.wmf

Figure 1 Inductor