



# Lexmark E260, E260d, and E260dn Series

---

## User's Guide

**May 2008**

**[www.lexmark.com](http://www.lexmark.com)**

---

Lexmark and Lexmark with diamond design are trademarks of Lexmark International, Inc., registered in the United States and/or other countries. All other trademarks are the property of their respective owners.

© 2008 Lexmark International, Inc.

All rights reserved.

740 West New Circle Road  
Lexington, Kentucky 40550

# Contents

<b>Safety information.....</b>	<b>7</b>
<b>Learning about the printer.....</b>	<b>8</b>
Finding information about the printer.....	8
Printer configurations.....	9
Understanding the printer control panel.....	12
<b>Additional printer setup.....</b>	<b>14</b>
Selecting a location for the printer.....	14
Installing internal options.....	15
Accessing the system board to install internal options.....	15
Installing a memory card .....	16
Installing hardware options.....	17
Installing a 250- or 550-sheet drawer .....	17
Attaching cables.....	18
Installing printer software.....	19
<b>Interpreting the printer control panel lights.....</b>	<b>21</b>
Understanding the printer control panel light sequences.....	21
Understanding the primary light sequences.....	21
Understanding the secondary error light sequences.....	28
Understanding the secondary paper jam light sequences .....	34
Understanding the printer configuration menus.....	38
Printing the printer settings configuration sheet .....	38
<b>Loading paper and specialty media.....</b>	<b>40</b>
Setting the paper size and paper type.....	40
Configuring Universal paper settings.....	40
Loading the standard 250-sheet tray.....	41
Loading the optional 250- or 550-sheet tray.....	45
Using the manual feeder.....	46
Using the standard exit bin and paper stop.....	47
Paper capacities.....	47
Linking and unlinking trays.....	48
Linking trays.....	48
Unlinking trays .....	49
Assigning a Custom Type <x> name.....	49

Changing a Custom Type <x> name ..... 50

**Paper and specialty media guide.....51**

Paper guidelines.....51  
    Paper characteristics..... 51  
    Unacceptable paper ..... 52  
    Selecting paper..... 52  
    Selecting preprinted forms and letterhead..... 52  
    Using recycled paper and other office papers ..... 53  
Storing paper..... 53  
Supported paper sizes, types, and weights..... 54  
    Paper types and weights supported by the printer ..... 54  
    Paper sizes supported by the printer ..... 55

**Printing.....57**

Printing a document.....57  
Printing on both sides of the paper.....58  
    Printer models and printing on both sides of the paper..... 58  
    Printing on both sides of the paper automatically ..... 58  
    Printing on both sides of the paper manually..... 59  
Printing specialty documents.....60  
    Tips on using letterhead..... 60  
    Tips on using transparencies ..... 61  
    Tips on using envelopes..... 61  
    Tips on using labels..... 62  
    Tips on using card stock..... 63  
    Printing a booklet ..... 63  
Printing information pages.....63  
    Printing the menu settings and network setup pages ..... 63  
    Printing the print quality test pages ..... 64  
Setting Jam Recovery.....65  
Canceling a print job.....65

**Understanding printer menus.....67**

Menus on the Embedded Web Server.....67  
Using the Embedded Web Server.....68  
Installing the Local Printer Settings Utility.....69  
Using the Local Printer Settings Utility.....69  
Using the Finishing menu.....70  
Paper menu.....71  
    Default Source menu..... 71

Size/Type menu.....	71
Paper Texture menu .....	74
Paper Weight menu.....	75
Paper Loading menu .....	75
Custom Types menu.....	76
Universal Setup menu.....	76
<b>Settings menu.....</b>	<b>77</b>
General Settings menu .....	77
Setup menu .....	79
Finishing menu.....	80
Quality menu.....	82
PostScript menu.....	83
PCL Emul menu .....	83
<b>Network/Ports menu.....</b>	<b>85</b>
Network menu .....	85
Network Card menu.....	86
TCP/IP menu .....	87
IPv6 menu.....	88
AppleTalk menu .....	88
USB menu .....	89
Parallel menu.....	90

**Understanding printer messages.....93**

Checking the virtual display.....	93
List of status and error messages.....	93

**Maintaining the printer.....99**

Cleaning the exterior of the printer.....	99
Storing supplies.....	99
Conserving supplies.....	99
Checking the status of supplies.....	100
Checking the status of supplies from a network computer .....	100
Ordering supplies.....	101
Ordering toner cartridges.....	101
Ordering a photoconductor kit .....	102
Replacing supplies.....	102
Replacing the toner cartridge .....	102
Replacing the photoconductor kit .....	104
Recycling Lexmark products.....	107
Moving the printer.....	107
Before moving the printer .....	107
Moving the printer to another location.....	107

Shipping the printer .....	107
----------------------------	-----

## **Administrative support.....108**

Adjusting Power Saver.....	108
Restoring the factory default settings.....	108
Checking the device status.....	109
Viewing reports.....	109
Restricting access to printer menus.....	110
Setting up e-mail alerts.....	110
Configuring supply notifications.....	111
Copying printer settings to other printers.....	111

## **Clearing jams.....113**

Avoiding jams.....	113
Accessing jam areas.....	114
Understanding jam lights and access locations.....	114
Clearing jams behind the photoconductor kit and toner cartridge.....	118
Clearing jams from the standard exit bin.....	120
Clearing jams from Tray 1.....	120
Clearing jams from Tray 2.....	122
Clearing jams in the manual feeder.....	123
Clearing jams behind the rear door.....	124

## **Troubleshooting.....126**

Solving basic printer problems.....	126
Solving printing problems.....	126
Jobs do not print.....	126
Multiple-language PDFs do not print.....	127
Job takes longer than expected to print.....	127
Job prints from the wrong tray or on the wrong paper.....	127
Incorrect characters print.....	128
Tray linking does not work.....	128
Large jobs do not collate.....	128
Solving option problems.....	129
Option does not operate correctly or quits after it is installed.....	129
Drawers.....	129
Memory card.....	130
Solving paper feed problems.....	130
Paper frequently jams.....	130
Paper jam lights remain on after jam is cleared.....	130

Page that jammed does not reprint after the jam is cleared .....	131
Solving print quality problems.....	131
Isolating print quality problems.....	131
Blank pages.....	132
Characters have jagged or uneven edges .....	132
Clipped images.....	132
Gray background .....	133
Ghost images.....	133
Incorrect margins.....	134
Paper curl.....	134
Print is too dark.....	134
Print is too light .....	135
Skewed print.....	136
Toner fog or background shading appears on the page .....	136
Toner rubs off .....	136
Toner specks.....	137
Transparency print quality is poor.....	137
Streaked horizontal lines.....	137
Streaked vertical lines .....	138
Solid black or white streaks appear on transparencies or paper.....	139
Contacting Customer Support.....	139

**Notices.....140**

Product information.....	140
Edition notice.....	140
Power consumption.....	146

**Index.....153**

# Safety information

Connect the power supply cord to a properly grounded electrical outlet that is near the product and easily accessible.

 **CAUTION—SHOCK HAZARD:** Do not set up this product or make any electrical or cabling connections, such as the power supply cord or telephone, during a lightning storm.

Refer service or repairs, other than those described in the user documentation, to a professional service person.

This product is designed, tested, and approved to meet strict global safety standards with the use of specific Lexmark components. The safety features of some parts may not always be obvious. Lexmark is not responsible for the use of other replacement parts.

 **CAUTION—SHOCK HAZARD:** Make sure that all external connections (such as Ethernet and telephone system connections) are properly installed in their marked plug-in ports.

 **CAUTION—POTENTIAL INJURY:** This product uses a laser. Use of controls or adjustments or performance of procedures other than those specified herein may result in hazardous radiation exposure.

This product uses a printing process that heats the print media, and the heat may cause the media to release emissions. You must understand the section in your operating instructions that discusses the guidelines for selecting print media to avoid the possibility of harmful emissions.

 **CAUTION—HOT SURFACE:** The fuser and the inside of the printer near the fuser may be hot. To reduce the risk of injury from a hot component, allow the surface to cool before removing paper from this area.

 **CAUTION—POTENTIAL INJURY:** Use the handholds on the sides of the printer to lift it, and make sure your fingers are not under the printer when you set it down.

 **CAUTION—POTENTIAL INJURY:** Do not twist, bind, crush, or place heavy objects on the power cord. Do not subject the power cord to abrasion or stress. Do not pinch the power cord between objects such as furniture and walls. If the power cord is misused, a risk of fire or electrical shock results. Inspect the power cord regularly for signs of misuse. Remove the power cord from the electrical outlet before inspecting it.

 **CAUTION—SHOCK HAZARD:** When accessing the system board, turn the printer off, and then unplug the power cord from the wall outlet before continuing. If you have other devices attached to the printer, then turn them off as well and unplug any cables going to the printer.

 **CAUTION—SHOCK HAZARD:** If you are installing an optional drawer after setting up the printer, then turn the printer off and unplug the power cord from the wall outlet before continuing.

 **CAUTION—SHOCK HAZARD:** If you are installing a memory card after setting up the printer, then turn the printer off and unplug the power cord from the wall outlet before continuing.

 **CAUTION—SHOCK HAZARD:** To avoid the risk of electric shock when cleaning the exterior of the printer, unplug the power cord from the wall outlet and disconnect all cables from the printer before proceeding.

# Learning about the printer

## Finding information about the printer

### Setup information

Description	Where to find
The <i>Setup</i> information gives you instructions for setting up the printer. Follow the set of instructions for local, network, or wireless, depending on what you need.	You can find the <i>Setup</i> information on the side of the printer box or on the Lexmark Web site at <a href="http://www.lexmark.com">www.lexmark.com</a> .

### Help

Description	Where to find
The Help gives you instructions for using the software.	While in any Lexmark software program, click <b>Help, Tips → Help</b> , or <b>Help → Help Topics</b> .

### Customer support

Description	Where to find (North America)	Where to find (rest of world)
<b>Telephone support</b>	<p>Call us at</p> <ul style="list-style-type: none"> <li>US: 1-800-332-4120 Monday–Friday (8:00 AM–11:00 PM ET) Saturday (Noon–6:00 PM ET)</li> <li>Canada: 1-800-539-6275 Monday–Friday (8:00 AM–11:00 PM ET) Saturday (Noon–6:00 PM ET)</li> <li>Mexico: 001-888-377-0063 Monday–Friday (8:00 AM–8:00 PM ET)</li> </ul> <p><b>Note:</b> Telephone numbers and support times may change without notice. For the most recent telephone numbers available, see the printed warranty statement that came with your printer.</p>	<p>Telephone numbers and support hours vary by country or region.</p> <p>Visit our Web site at <a href="http://www.lexmark.com">www.lexmark.com</a>. Select a country or region, and then select the Customer Support link.</p> <p><b>Note:</b> For additional information about contacting Lexmark, see the printed warranty that came with your printer.</p>
<b>E-mail support</b>	<p>For e-mail support, visit our Web site: <a href="http://www.lexmark.com">www.lexmark.com</a>.</p> <ol style="list-style-type: none"> <li>1 Click <b>SUPPORT</b>.</li> <li>2 Click <b>Technical Support</b>.</li> <li>3 Select your printer type.</li> <li>4 Select your printer model.</li> <li>5 From the Support Tools section, click <b>e-Mail Support</b>.</li> <li>6 Complete the form, and then click <b>Submit Request</b>.</li> </ol>	<p>E-mail support varies by country or region, and may not be available in some instances.</p> <p>Visit our Web site at <a href="http://www.lexmark.com">www.lexmark.com</a>. Select a country or region, and then select the Customer Support link.</p> <p><b>Note:</b> For additional information about contacting Lexmark, see the printed warranty that came with your printer.</p>



# Printer configurations

## Basic model

The following illustration shows the printer front with its basic features or parts:

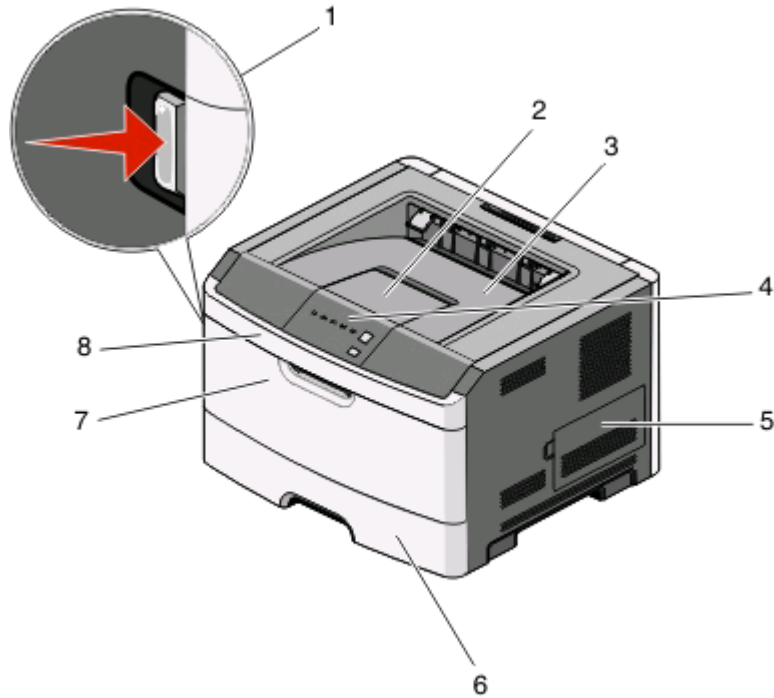

<b>1</b>	Front door release button
<b>2</b>	Paper stop
<b>3</b>	Standard exit bin
<b>4</b>	Printer control panel
<b>5</b>	System board door
<b>6</b>	Standard 250-sheet tray (Tray 1)
<b>7</b>	Manual feeder door
<b>8</b>	Front door

The following illustration shows the printer back with its basic features or parts:

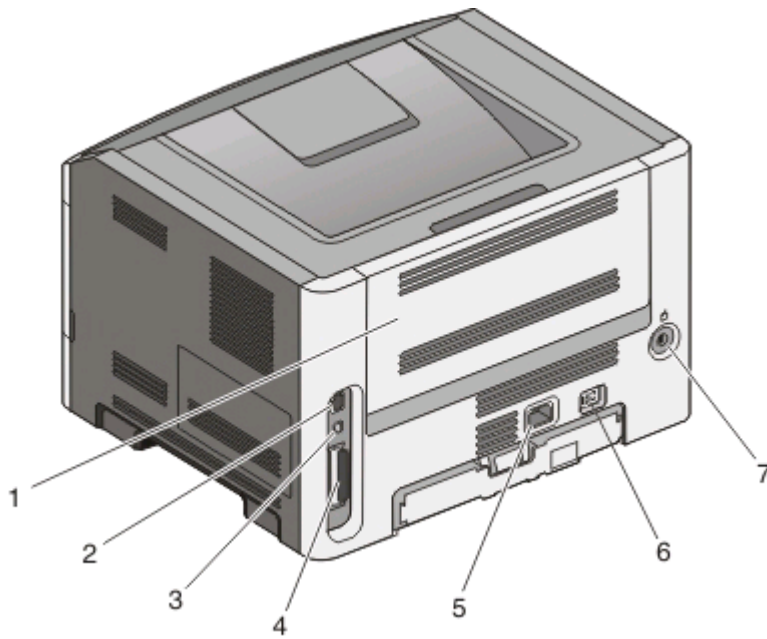

<b>1</b>	Rear door
<b>2</b>	Ethernet port *
<b>3</b>	USB port
<b>4</b>	Parallel port
<b>5</b>	Printer power cord socket
<b>6</b>	Power button (On/Off switch)
<b>7</b>	Locking device

\* The Ethernet port is a feature on network models only.

## Configured models

The following illustration shows the printer configured with an optional 250-sheet drawer:

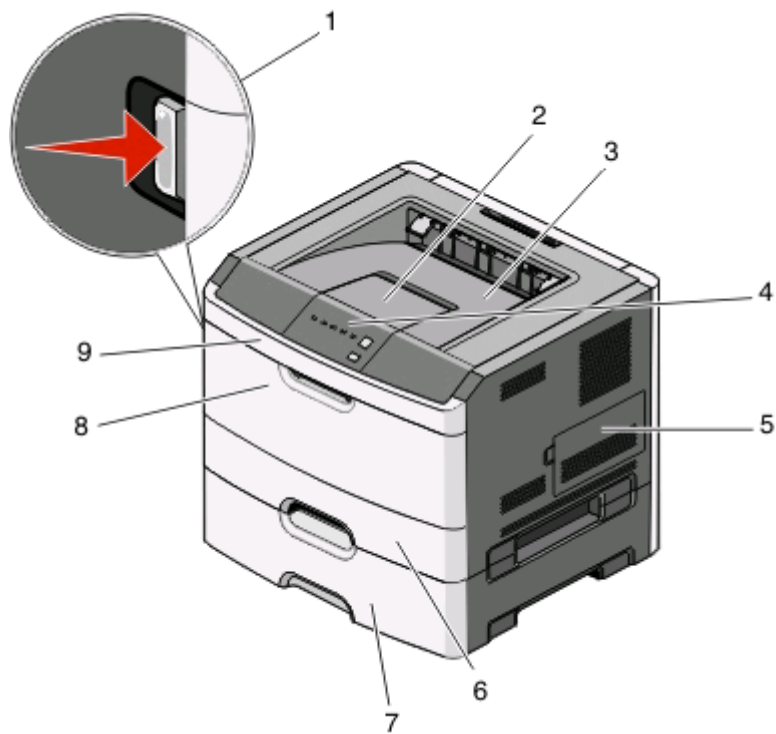

<b>1</b>	Front door release button
<b>2</b>	Paper stop
<b>3</b>	Standard exit bin
<b>4</b>	Printer control panel
<b>5</b>	System board door
<b>6</b>	Standard 250-sheet tray (Tray 1)
<b>7</b>	Optional 250-sheet drawer (Tray 2)
<b>8</b>	Manual feeder door
<b>9</b>	Front door

The following illustration shows the printer configured with an optional 550-sheet drawer:

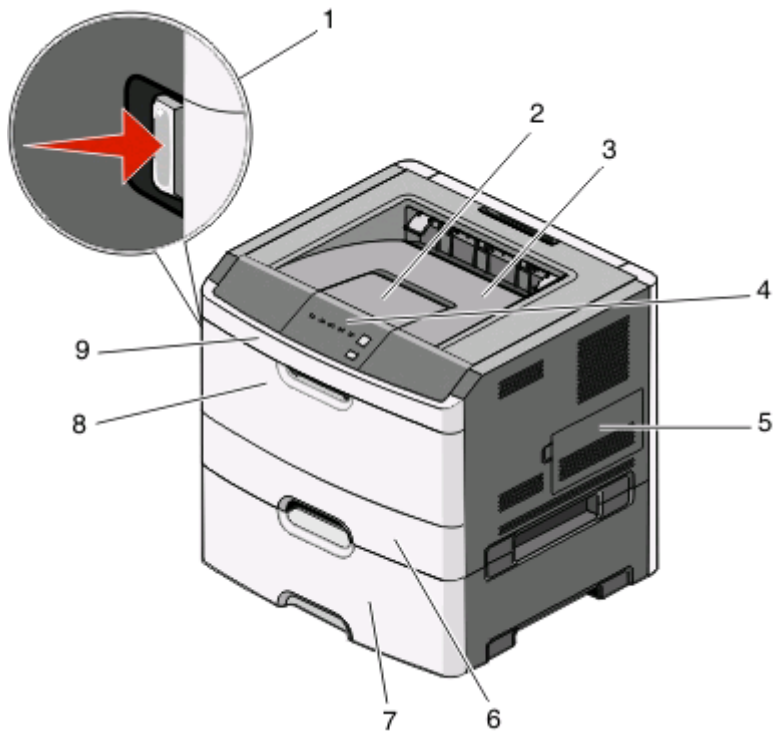





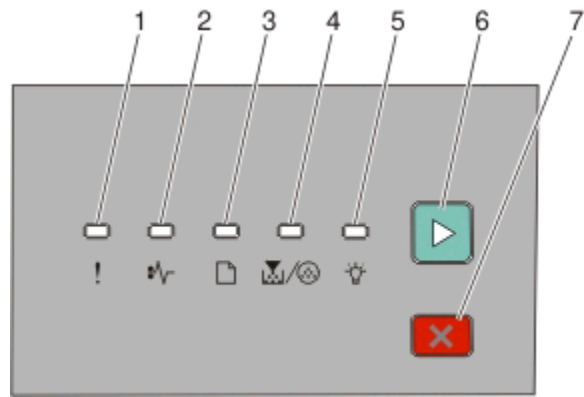

<b>1</b>	Front door release button
<b>2</b>	Paper stop
<b>3</b>	Standard exit bin
<b>4</b>	Printer control panel
<b>5</b>	System board door
<b>6</b>	Standard 250-sheet tray (Tray 1)
<b>7</b>	Optional 550-sheet drawer (Tray 2)
<b>8</b>	Manual feeder door
<b>9</b>	Front door

## Understanding the printer control panel

The printer control panel features six lights and two buttons.



Item		
1	Error light	
2	Jam light	
3	Load paper light	
4	Toner light	
5	Ready light	
6	Continue button	
7	Stop button	

# Additional printer setup

## Selecting a location for the printer

When selecting a location for the printer, leave enough room to open trays, covers, and doors. If you plan to install any options, leave enough room for them also. It is important to:

- Make sure airflow in the room meets the latest revision of the ASHRAE 62 standard.
- Provide a flat, sturdy, and stable surface.
- Keep the printer:
  - Away from the direct airflow of air conditioners, heaters, or ventilators
  - Free from direct sunlight, humidity extremes, or temperature fluctuations
  - Clean, dry, and free of dust
- Allow the following recommended amount of space around the printer for proper ventilation:

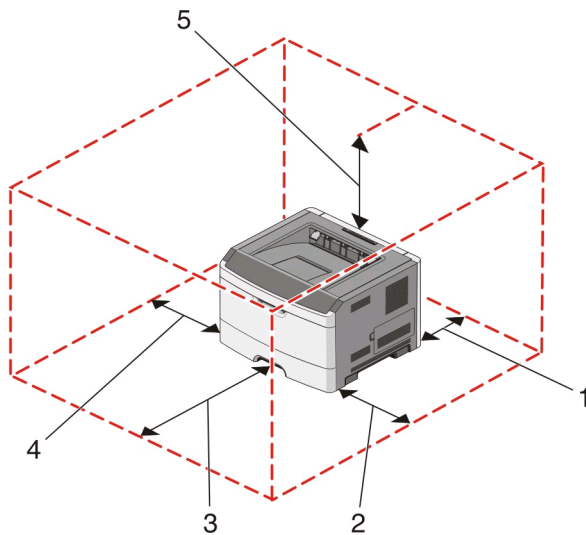

<b>1</b>	Rear	300 mm (12.0 in.)
<b>2</b>	Front	300 mm (12.0 in.)
<b>3</b>	Right side	200 mm (8.0 in.)
<b>4</b>	Left side	12.7 mm (0.5 in.)
<b>5</b>	Top	300 mm (12.0 in.)

# Installing internal options

## Accessing the system board to install internal options

**CAUTION—SHOCKHAZARD:** When accessing the system board, turn the printer off, and then unplug the power cord from the wall outlet before continuing. If you have other devices attached to the printer, then turn them off as well and unplug any cables going to the printer.

- 1 As you face the printer, the system board door is on the right side. Open the system board door.

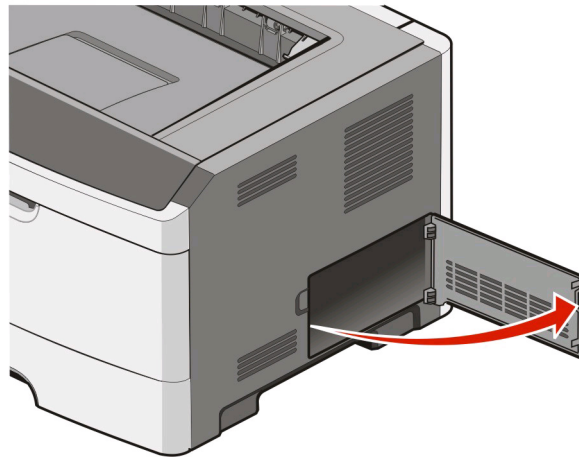

- 2 Use the following illustration to locate the appropriate connector.

**Warning—Potential Damage:** System board electronic components are easily damaged by static electricity. Touch something metal on the printer before touching any system board electronic components or connectors.

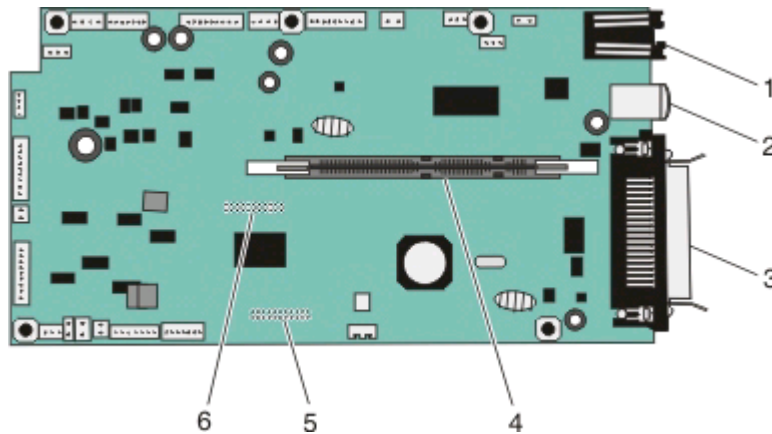

1	Ethernet connector <b>Note:</b> The Ethernet port is a feature on network models only.
2	USB port
3	Parallel connector
4	Memory card connector
5	Optional card connector
6	Optional card connector

## Installing a memory card

**CAUTION—SHOCK HAZARD:** If you are installing internal options, memory cards, flash memory, or a firmware card after setting up the printer, turn the printer off and unplug it from the wall outlet before continuing. If you have other devices attached to the printer, then turn them off as well and unplug any cables going to the printer.

**Warning—Potential Damage:** System board electronic components are easily damaged by static electricity. Touch something metal on the printer before touching any system board electronic components or connectors.

An optional memory card can be purchased separately and attached to the system board. To install the memory card:

- 1 Access the system board.

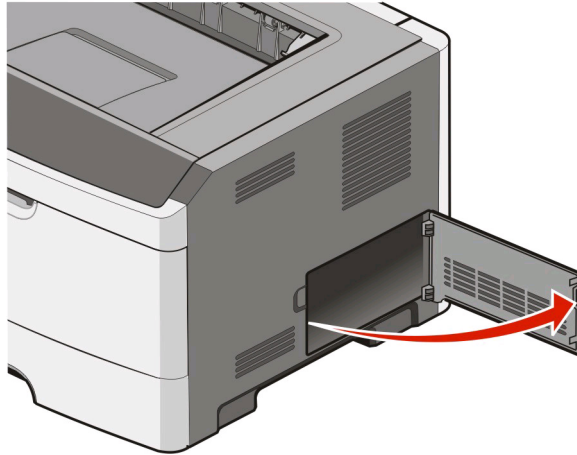

- 2 Unpack the memory card.

**Note:** Avoid touching the connection points along the edge of the card.

- 3 Align the memory card with its connector on the system board. Push the latches on the connector open if they are not open already.

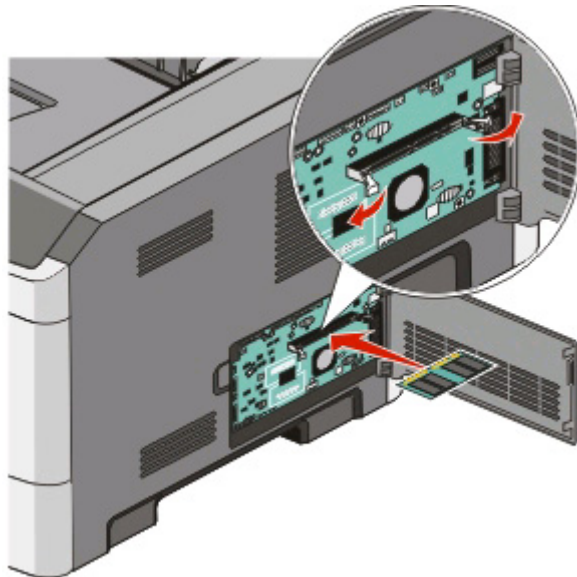



- 4 Push the memory card into the connector until the latches *snap* into place.

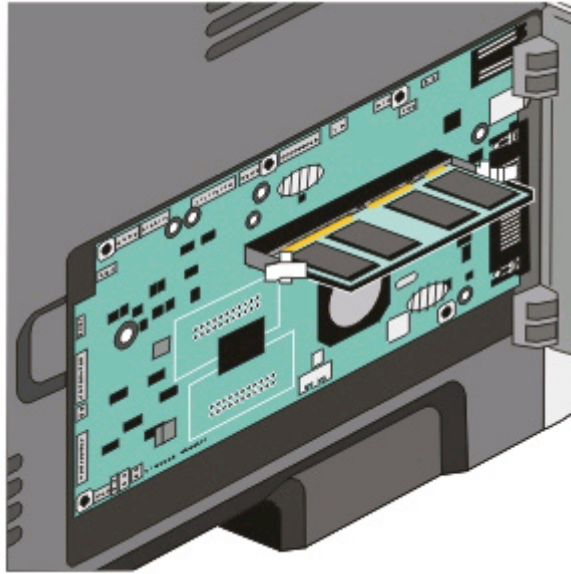

- 5 Close the system board door.

## Installing hardware options

### Installing a 250- or 550-sheet drawer

The printer supports one optional drawer; you can install a 250- or 550-sheet drawer.

**⚠ CAUTION—SHOCK HAZARD:** If you are installing an optional drawer after setting up the printer, then turn the printer off and unplug the power cord from the wall outlet before continuing

- 1 Unpack the drawer, and then remove any packing material from the outside of the drawer.
- 2 Remove the tray from the support unit.

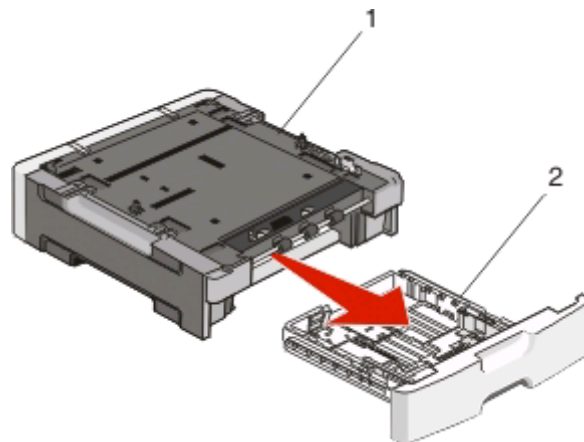

1	Support unit
2	Tray

- 3 Remove any packing material and tape from inside the tray.
- 4 Insert the tray into the support unit.
- 5 Place the drawer in the location chosen for the printer.
- 6 Align the printer with the drawer, and then lower the printer into place.

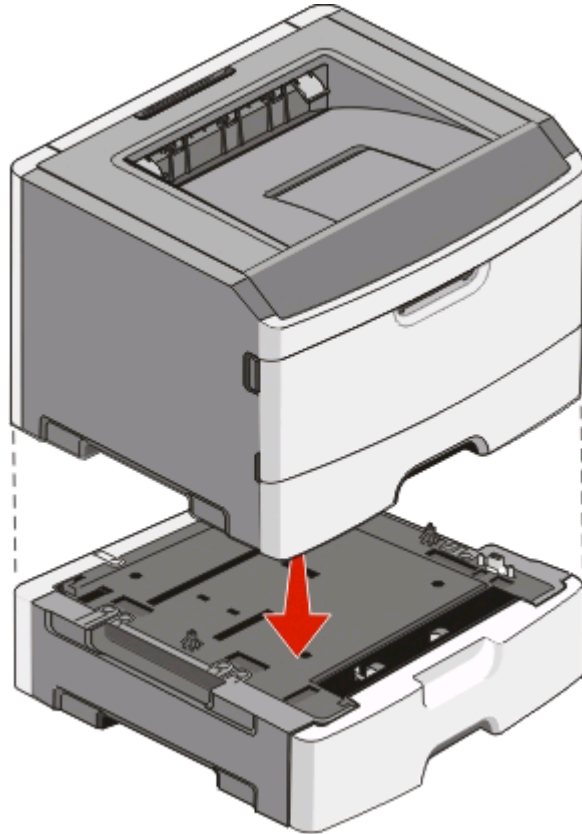

## Attaching cables

- 1 Connect the printer to a computer or a network.
  - For a local connection, use a USB or parallel cable.
  - For a network connection, use an Ethernet cable.
- 2 Connect the power cord to the printer first and then to a wall outlet.

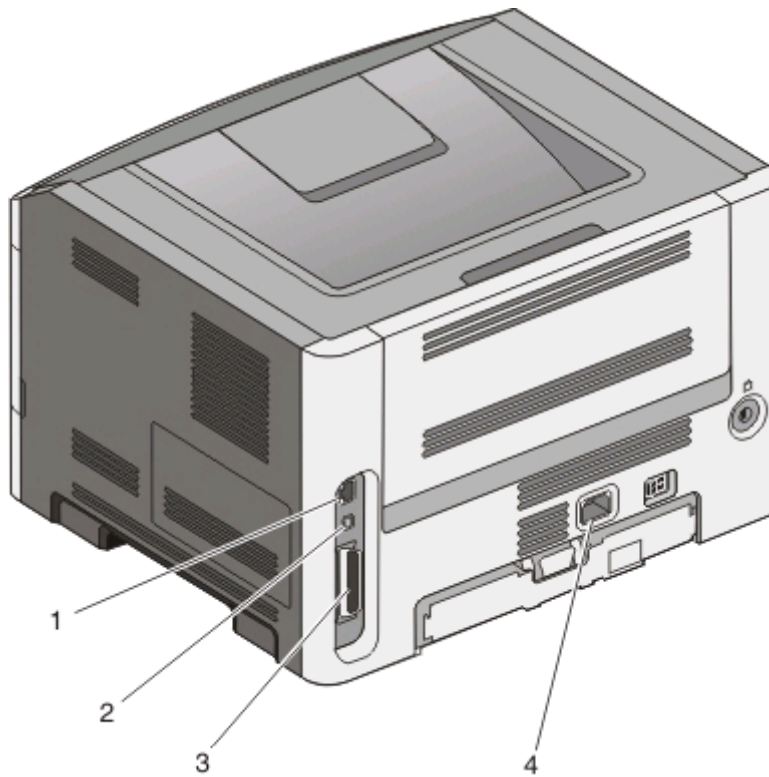

1	Ethernet port <b>Note:</b> The Ethernet port is a feature on network models only.
2	USB port
3	Parallel port
4	Printer power cord socket

## Installing printer software

A printer driver is software that lets the computer communicate with the printer. The printer software is typically installed during the initial printer setup. If you need to install the software after setup, follow these instructions:

### For Windows users

- 1 Close all open software programs.
- 2 Insert the *Software and Documentation CD*.
- 3 From the main installation dialog, click **Install**.
- 4 Follow the instructions on the screen.

### For Macintosh users

- 1 Close all open software applications.
- 2 Insert the *Software and Documentation CD*.

- 3 From the Finder desktop, double-click the printer CD icon that automatically appears.
- 4 Double-click the **Install** icon.
- 5 Follow the instructions on the screen.

## Using the World Wide Web

- 1 Go to the Lexmark Web site at **[www.lexmark.com](http://www.lexmark.com)**.
- 2 From the Drivers & Downloads menu, click **Driver Finder**.
- 3 Select your printer, and then select your operating system.
- 4 Download the driver and install the printer software.





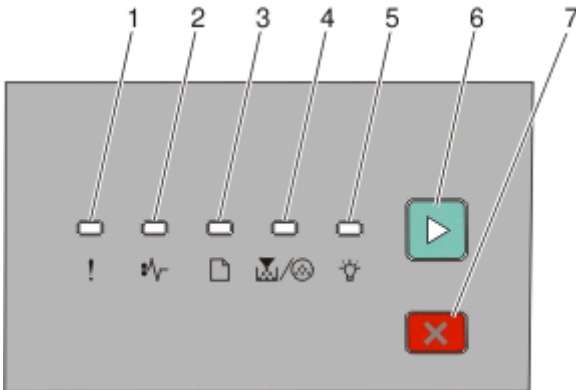

# Interpreting the printer control panel lights

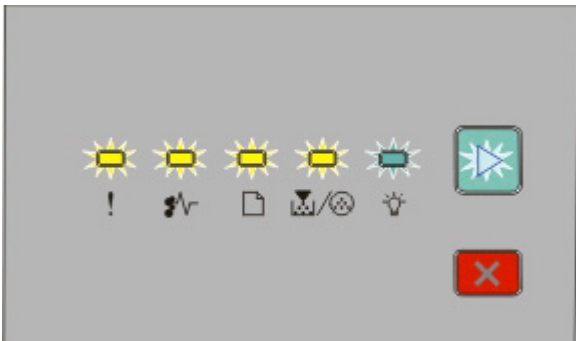

## Understanding the printer control panel light sequences



### Understanding the primary light sequences





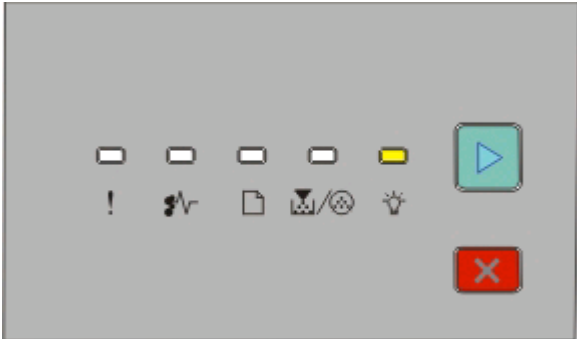



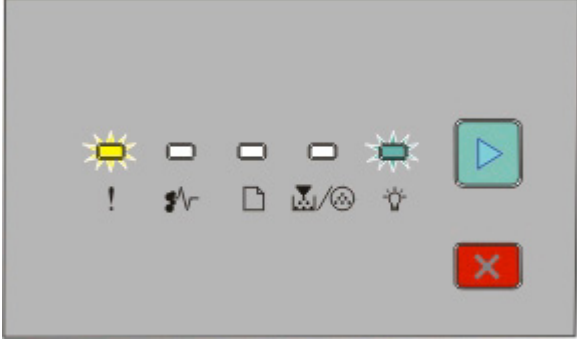





Printer control panel	Lights and buttons
	<ol style="list-style-type: none"> <li><b>1</b> Error</li> <li><b>2</b> Jam</li> <li><b>3</b> Load paper</li> <li><b>4</b> Toner</li> <li><b>5</b> Ready</li> <li><b>6</b> Continue</li> <li><b>7</b> Stop</li> </ol>

The printer control panel features six lights and two buttons. The lights can be on, off, blinking, or blinking slowly.

Light sequence	What you can do
 <p>Service Error</p> <ul style="list-style-type: none"> <li> - Blinking</li> <li> - Blinking</li> <li> - Blinking</li> <li> - Blinking</li> <li> - Blinking</li> <li> - Blinking</li> </ul>	<p>Turn the printer off and then on again. If the lights are still blinking, contact the manufacturer of your printer.</p>



Light sequence	What you can do
 <p>Replace PC Kit</p> <p>! - Blinking</p> <p>⌚/⚡ - Blinking</p> <p>▶ - On</p>	<p>Replace the photoconductor kit.</p>
 <p>Ready</p> <p>💡 - On (green)</p>	<p>Send a job to print.</p>
 <p>Power Saver</p> <p>💡 - On (yellow)</p>	<p>Send a job to print.</p>





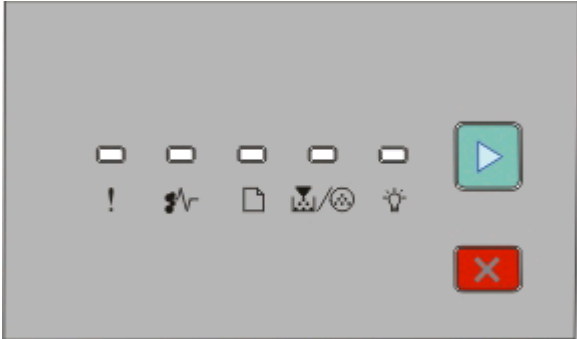
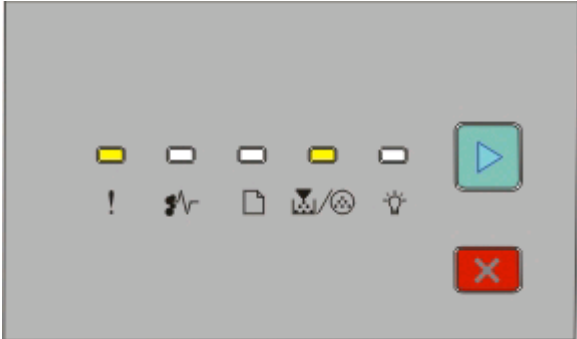
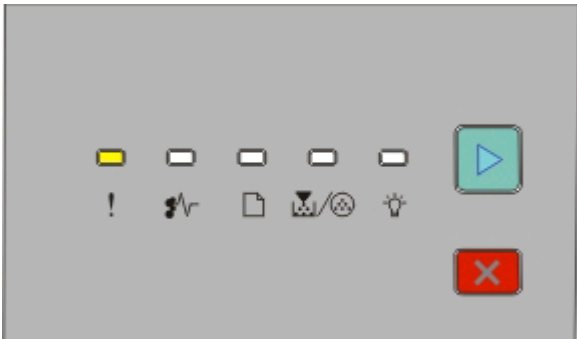



Light sequence	What you can do
 <p>Hex Trace Ready 💡 - Slowly Blinking</p>	<p>Use Hex Trace to troubleshoot printing problems.</p>
 <p>Busy 💡 - Blinking</p>	<p>Wait or press <b>X</b>.</p>
 <p>Flushing Buffer ⚠️ - Blinking 💡 - Blinking</p>	<p>Wait until the printer returns to the Ready state.</p>

Light sequence	What you can do
 <p>Waiting   - On   - On</p>	<p>Wait for the light sequence to clear.</p>
 <p>Canceling job   - On   - On   - On   - On   - On   - On</p>	<p>Wait for the light sequence to clear.</p>
 <p>Invalid Engine Code or Invalid Network Code   - On   - On</p>	<p>Press and release . To avoid this light sequence in the future, make sure you use valid code when programming the printer.</p>



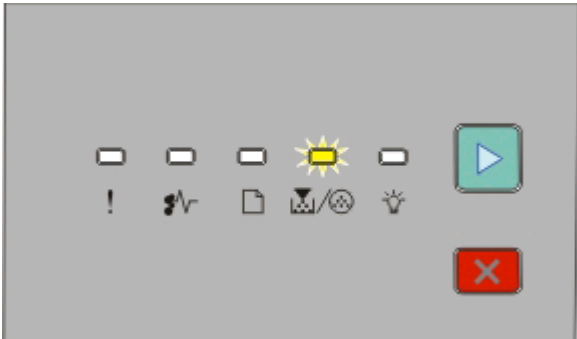



Light sequence	What you can do
 <p data-bbox="149 562 263 592">Not ready</p> <p data-bbox="149 600 233 630">▶ - On</p>	<p data-bbox="1091 205 1458 268">Press and release either ▶ or ✕ to return to the Ready state.</p>
 <p data-bbox="149 1008 451 1037">Cartridge region mismatch</p> <p data-bbox="149 1045 233 1075">! - On</p> <p data-bbox="149 1083 282 1113">⚠/⊗ - On</p>	<p data-bbox="1091 651 1458 714">Replace the toner cartridge with one suitable for your region.</p>
 <p data-bbox="149 1495 334 1524">Close front door</p> <p data-bbox="149 1533 233 1562">! - On</p>	<p data-bbox="1091 1138 1325 1167">Close the front door.</p>

Light sequence	What you can do
 <p>Load paper in Tray 1 or Tray 2</p> <p>☐ - On</p> <p>▶ - On</p>	<p>Load paper in Tray 1 or Tray 2.</p>
 <p>Load paper in manual feeder</p> <p>☐ - On</p>	<p>Load paper in the manual feeder.</p>
 <p>Remove paper from the standard output bin</p> <p>☐ - Blinking</p>	<p>Remove printed pages from the standard exit bin, and then press and release ▶ to clear the light sequence and continue printing.</p>

Light sequence	What you can do
 <p>Cartridge is low    - On   - On</p>	<ul style="list-style-type: none"> <li>• Press and release  to clear the light sequence and continue processing the print job.</li> <li>• With the printer turned off, remove the toner cartridge and shake it to extend its life.</li> <li>• Replace the toner cartridge, and then turn the printer on.</li> </ul>
 <p>PC Kit life warning    - Blinking   - On</p>	<ul style="list-style-type: none"> <li>• Press and release  to clear the light sequence and continue processing the print job.</li> <li>• Replace the photoconductor kit.</li> </ul>

The following light sequences show that there is a secondary error code or secondary jam code to read:

Light sequence	What you can do
 <p>Printer error   - On  - On</p>	<p>Press  twice quickly to see the secondary error code. For more information, see “Understanding the secondary error light sequences” on page 28.</p>

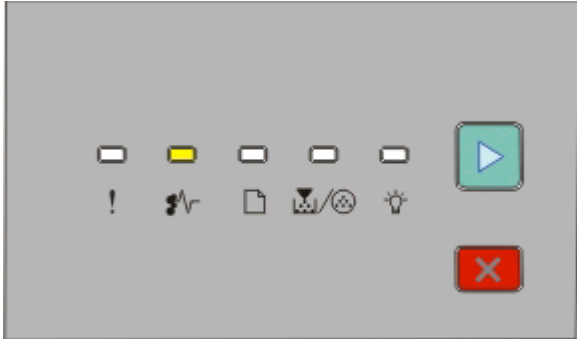

Light sequence	What you can do
 <p data-bbox="147 562 264 590">Paper jam</p> <p data-bbox="147 600 240 630">! - On</p> <p data-bbox="147 640 233 669">▶ - On</p>	<p data-bbox="1019 205 1469 363">Press ▶ twice quickly to see the secondary paper jam code. For more information, see “Understanding the secondary paper jam light sequences” on page 34.</p>



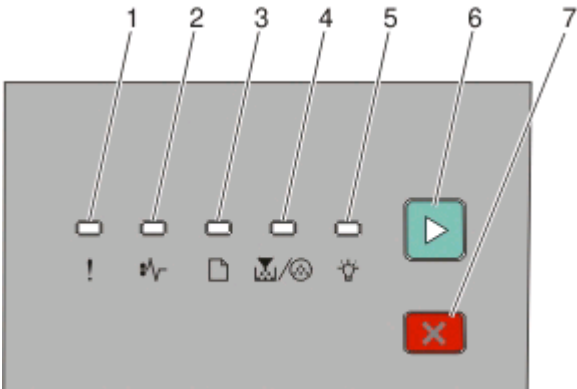

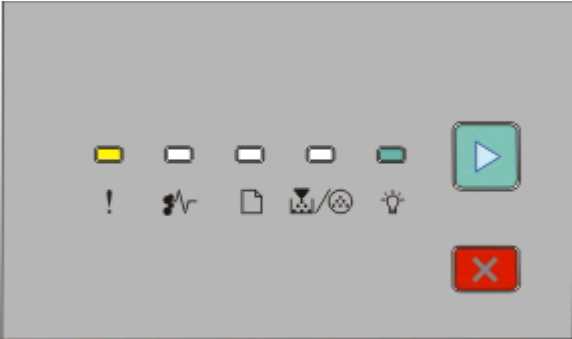
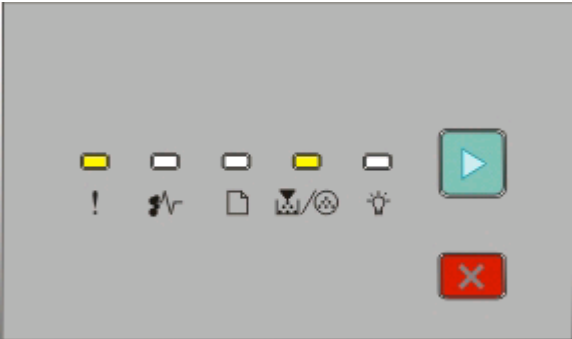
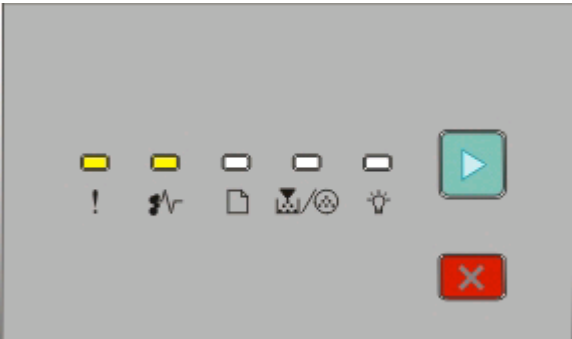

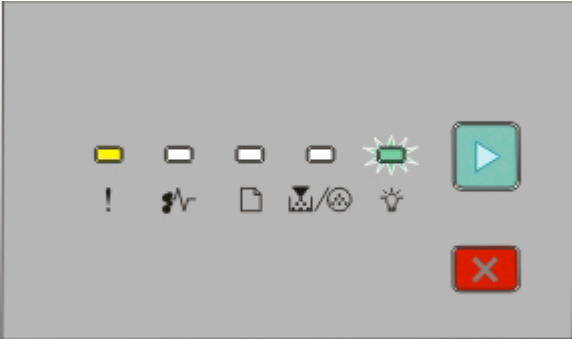
## Understanding the secondary error light sequences

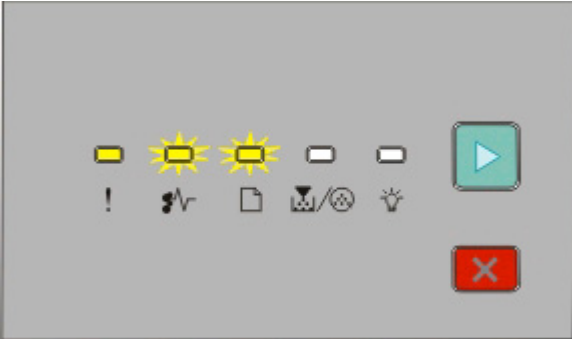

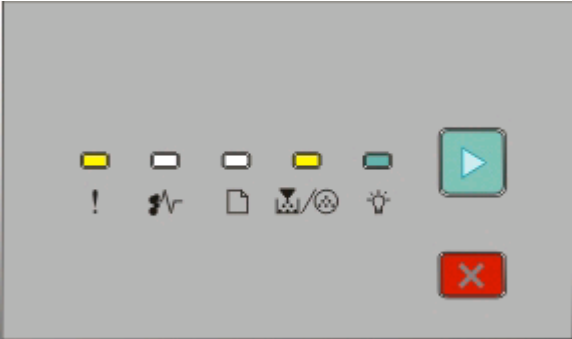
When the ▶ and ! lights are on simultaneously, press ▶ twice quickly to see the secondary error code.

Printer control panel	Lights and buttons
	<ul style="list-style-type: none"> <li data-bbox="1089 909 1179 936"><b>1</b> Error</li> <li data-bbox="1089 947 1166 974"><b>2</b> Jam</li> <li data-bbox="1089 984 1252 1012"><b>3</b> Load paper</li> <li data-bbox="1089 1022 1187 1050"><b>4</b> Toner</li> <li data-bbox="1089 1060 1192 1087"><b>5</b> Ready</li> <li data-bbox="1089 1098 1227 1125"><b>6</b> Continue</li> <li data-bbox="1089 1136 1175 1163"><b>7</b> Stop</li> </ul>

Light sequences	What you can do
 <p>Complex page, some data may not have printed</p> <p>! - On        ⚡ - On        ▶ - On</p>	<ul style="list-style-type: none"> <li>• Simplify the page by reducing the amount of text, graphics, fonts, or macros.</li> <li>• Set <b>Page Protect</b> to On.</li> <li>• Install additional printer memory. For more information, see “Installing a memory card” on page 16.</li> </ul>
 <p>Insufficient memory to collate job</p> <p>! - On        ⚡/⊕ - On        ▶ - On</p>	<ul style="list-style-type: none"> <li>• Press ▶ to collate the remaining pages of the job.</li> <li>• Press ✕ to cancel the print job.</li> <li>• Simplify the page by reducing the amount of text, graphics, fonts, or macros.</li> <li>• Install additional printer memory. For more information, see “Installing a memory card” on page 16.</li> </ul>
 <p>Network interface errors</p> <p>! - On        ⚡ - On ▶ - On</p>	<p>Check your network connections.</p>

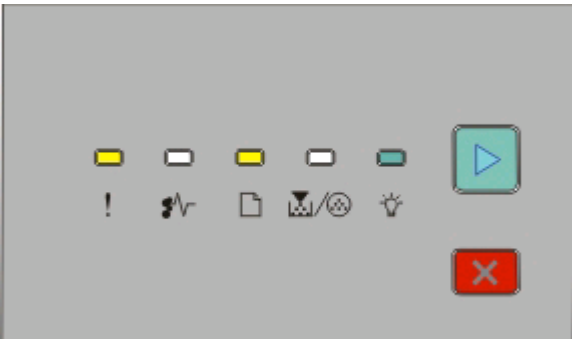
Light sequences	What you can do
 <p>Insufficient memory to support Resource Save feature</p> <p>! - On        ⚡ - On        📄 - On        🌐 - On        💡 - On        ▶ - On</p>	<p>Install additional printer memory.</p>
 <p>ENA connection lost</p> <p>! - On        ⚡ - On        📄 - On        🌐 - On        💡 - On        ▶ - On</p>	<p>Reestablish the connection with the network.</p>
 <p>Host interface disabled</p> <p>! - On        ⚡ - On        📄 - On        🌐 - On        💡 - On        ▶ - On</p>	<p>Press ▶ to clear the code. The printer discards any print jobs previously sent.</p>

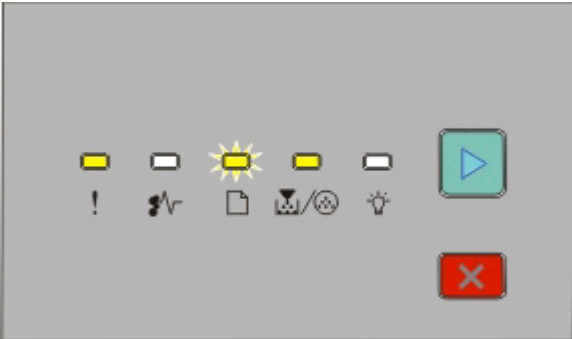

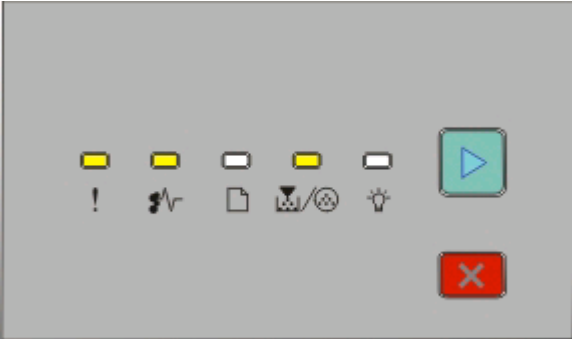
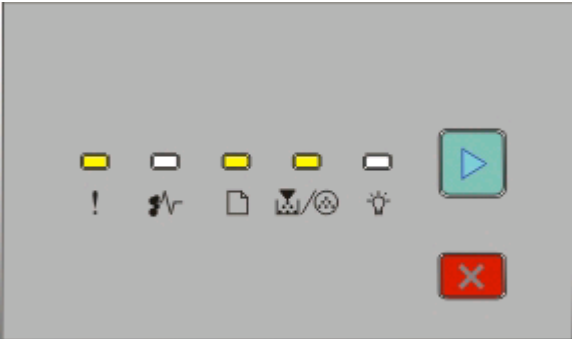

Light sequences	What you can do
 <p>Memory full</p> <p>! - On</p> <p>! - On</p> <p>! - On</p> <p>! - On</p>	<ul style="list-style-type: none"> <li>• Press  to clear the message and continue the print job.</li> <li>• Press and release  to cancel the print job.</li> <li>• Press and hold  to reset the printer.</li> <li>• To avoid this error in the future, simplify the print job. Reduce the complexity of the page by reducing the amount of text or graphics on the page and deleting unnecessary downloaded fonts or macros.</li> <li>• Install additional printer memory. For more information, see “Installing a memory card” on page 16.</li> </ul>
 <p>Short paper</p> <p>! - On</p> <p>! - On</p> <p>! - On</p> <p>! - On</p>	<ul style="list-style-type: none"> <li>• Make sure the paper you loaded is large enough.</li> <li>• Clear any paper jam.</li> <li>• Press  to clear the code and continue the print job.</li> </ul>
 <p>Invalid engine code</p> <p>! - On</p> <p>! - On</p> <p>! - On</p>	<p>Download valid engine code to the internal print server.</p>

Light sequences	What you can do
 <p>The image shows a printer control panel with five indicator lights and two buttons. From left to right: a yellow light with an exclamation mark below it (On), a green light with a signal icon below it (Off), a yellow light with a document icon below it (Blinking), a green light with a signal icon below it (Off), and a blue light with a signal icon below it (Off). To the right are a green play button and a red stop button.</p> <p>Invalid network code</p> <ul style="list-style-type: none"> <li>! - On</li> <li>📄 - Blinking</li> <li>💡 - On</li> </ul>	<p>Download valid network code to the internal print server.</p>
 <p>The image shows a printer control panel with five indicator lights and two buttons. From left to right: a yellow light with an exclamation mark below it (On), a green light with a signal icon below it (Off), a yellow light with a document icon below it (Blinking), a yellow light with a document icon below it (On), a green light with a signal icon below it (Off), and a blue light with a signal icon below it (Off). To the right are a green play button and a red stop button.</p> <p>Cartridge region mismatch</p> <ul style="list-style-type: none"> <li>! - On</li> <li>📄 - Blinking</li> <li>🗑️/🗑️ - On</li> </ul>	<p>Replace the toner cartridge with one that is suitable for your region.</p>
 <p>The image shows a printer control panel with five indicator lights and two buttons. From left to right: a yellow light with an exclamation mark below it (On), a yellow light with a document icon below it (Blinking), a green light with a signal icon below it (Off), a green light with a signal icon below it (Off), and a blue light with a signal icon below it (Off). To the right are a green play button and a red stop button.</p> <p>Invalid refill, Change cartridge</p> <ul style="list-style-type: none"> <li>! - On</li> <li>📄 - Blinking</li> <li>💡 - On</li> </ul>	<p>Replace the toner cartridge. For more information, see "Replacing the toner cartridge" on page 102.</p>





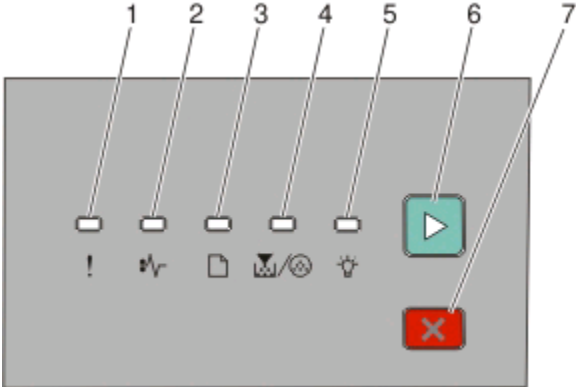

Light sequences	What you can do
 <p>Replace missing or defective cartridge</p> <p>! - On  ! - Blinking  ! - On</p>	<p>Replace the toner cartridge. For more information, see "Replacing the toner cartridge" on page 102.</p>
 <p>Cartridge part number unsupported by device</p> <p>! - On  ! - On  ! - On</p>	<p>Remove the unsupported toner cartridge, and then replace it with a supported toner cartridge.</p>

# Understanding the secondary paper jam light sequences



When the  and  lights are on, a paper jam has occurred. Press and release  twice quickly to display the secondary jam light sequence which can help pinpoint the site of the jam. Be sure to check all areas of the printer to ensure all the paper is removed. Once the jam is cleared, press  to continue printing.

Printer control panel	Lights and buttons
	<ol style="list-style-type: none"> <li><b>1</b> Error</li> <li><b>2</b> Jam</li> <li><b>3</b> Load paper</li> <li><b>4</b> Toner</li> <li><b>5</b> Ready</li> <li><b>6</b> Continue</li> <li><b>7</b> Stop</li> </ol>

## Secondary paper jam sequences on the printer control panel

Light sequence	What you can do to access the jam
 <p>200.yy Paper jam</p> <ul style="list-style-type: none"> <li> - On</li> <li> - On</li> <li> - On</li> </ul>	<p>Try one or more of the following:</p> <ul style="list-style-type: none"> <li>• Remove Tray 1.</li> <li>• Remove the photoconductor kit and toner cartridge unit.</li> </ul>

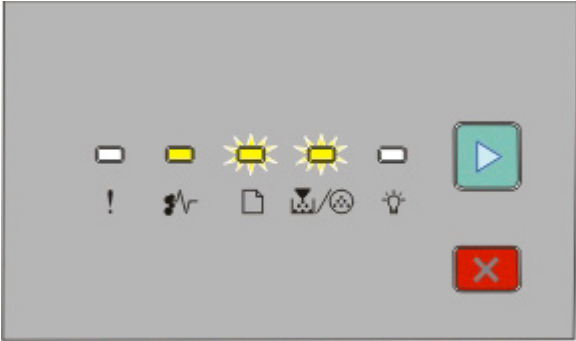
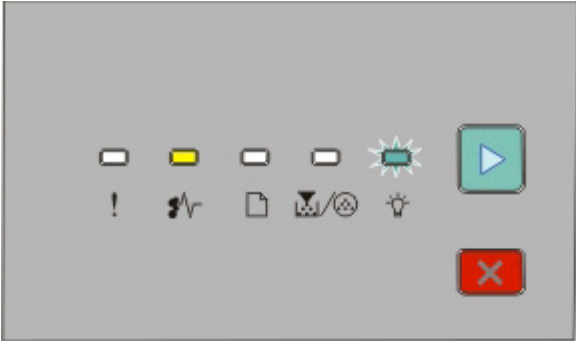

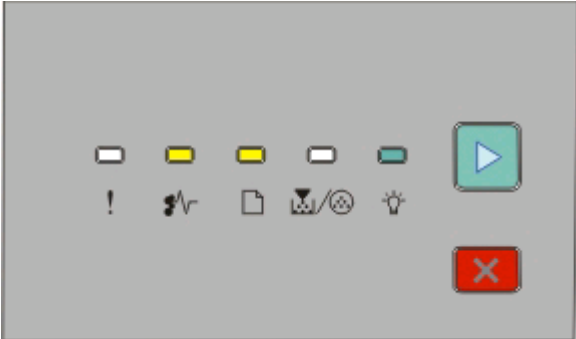

Light sequence	What you can do to access the jam
 <p>233.yy Paper jam</p> <ul style="list-style-type: none"> <li>! - On</li> <li>⚡ - On</li> <li>📄 - Blinking</li> <li>🔄 - Blinking</li> <li>▶ - On</li> </ul>	<p>Try one or more of the following:</p> <ul style="list-style-type: none"> <li>• Remove Tray 1.</li> <li>• Open the front door, and then open the rear door.</li> </ul>
 <p>234.yy Paper jam</p> <ul style="list-style-type: none"> <li>! - On</li> <li>⚡ - On</li> <li>💡 - Blinking</li> <li>▶ - On</li> </ul>	<p>Try one or more of the following:</p> <ul style="list-style-type: none"> <li>• Remove Tray 1.</li> <li>• Open the front door, and then open the rear door.</li> </ul>
 <p>235.yy Paper jam</p> <ul style="list-style-type: none"> <li>! - On</li> <li>⚡ - On</li> <li>📄 - Blinking</li> <li>💡 - Blinking</li> <li>▶ - On</li> </ul>	<p>Try one or more of the following:</p> <ul style="list-style-type: none"> <li>• Clear the jam at the standard exit bin.</li> <li>• Load paper supported by the duplex function. For more information, see “Paper sizes supported by the printer” on page 55.</li> </ul>

Light sequence	What you can do to access the jam
 <p>24x.yy Paper jam</p> <p>! - On</p> <p>⚡ - On</p> <p>📄 - On</p> <p>⚡/⊗ - On</p> <p>▶ - On</p>	<p>Try one or more of the following:</p> <ul style="list-style-type: none"> <li>• Remove Tray 1.</li> <li>• Remove the photoconductor kit and toner cartridge unit.</li> <li>• Remove Tray 2.</li> </ul>
 <p>24x.yy Paper jam</p> <p>! - On</p> <p>⚡ - On</p> <p>📄 - On</p> <p>⚡ - On</p> <p>▶ - On</p>	<p>Try one or more of the following:</p> <ul style="list-style-type: none"> <li>• Remove Tray 1.</li> <li>• Remove the photoconductor kit and toner cartridge unit.</li> <li>• Remove Tray 2.</li> </ul>





## Home Menu

 - On

 /  - On

 - On

 - On

**6** Press  until all the lights cycle.

The printer settings configuration sheet prints.

**Note:** The sheet prints only when the home menu light sequence is on.

# Loading paper and specialty media

This section explains how to load the 250- and 550-sheet trays, and the manual feeder. It also includes information about setting the Paper Size and Paper Type.

## Setting the paper size and paper type

Make sure the settings for the trays reflect the size and type of paper loaded in the trays. The factory default paper type setting is plain paper, so the paper type setting must be set manually for all trays that do not contain plain paper. Access the Paper menu through the Embedded Web Server if your printer is networked:

**1** Type the printer IP address in the address field of your Web browser.

**Note:** If you do not know the IP address of the printer, then print a network setup page and locate the IP address in the TCP/IP section.

**2** Click **Settings**.

**3** From the Paper menu, find the Size and Type for each input source.

**4** Select the paper size and paper type used most frequently from each input source.

**5** Click **Submit**.

If the printer is connected to a computer by a USB or parallel cable, use one of the following utilities to access the Paper menu, depending on your operating system:

- On a Windows computer, access the Paper menu through the Local Printer Settings Utility.
- On a Macintosh computer, access the Paper menu through the Printer Settings.

**Note:** The Paper Size and Type settings will be saved until you reset factory default settings. If you would like to override the Paper Size and Type settings for a special print job, do one of the following:

- For Windows users, click **File** → **Print**, and then click **Properties**, **Preferences**, **Options**, or **Setup**.
- For Macintosh users, choose **File** > **Print**, and then adjust the settings from the print dialog and pop-up menus.

## Configuring Universal paper settings

The Universal Paper Size is a user-defined setting that lets you print on paper sizes that are not preset in the printer menus. Defining a specific height and width measurement for the Universal paper size, in the portrait orientation, allows the printer to support the size. Specify all of the following Universal size settings for your paper:

- Units of measure (inches or millimeters)
- Portrait Width
- Portrait Height

**Note:** The smallest supported Universal size is 76.2 x 127 mm (3 x 5 in.); the largest is 216 x 356 mm (8.5 x 14 in.).

• If the printer is on a network, open the Embedded Web Server:

**1** Type the printer IP address into the address field of your Web browser.

**Note:** If you do not know the IP address of the printer, then print a network setup page and locate the IP address in the TCP/IP section.

**2** Click **Settings**.



- 3 From the Paper Menu, click **Universal Setup**.
  - 4 Select the unit of measure in inches or millimeters.
  - 5 Enter the paper width under Portrait Width.
  - 6 Enter the paper height under Portrait Height.
  - 7 Click **Submit**.
  - 8 Find the tray in which you will load the Universal paper, and then set the Paper Size to **Universal**.
  - 9 Click **Submit**.
- If the printer is connected to a computer by a USB or parallel cable, open the Local Printer Settings Utility for Windows or Printer Settings for Macintosh. One of these utilities installs with your printer software. Under the Paper menu, select **Universal** in the Paper Size selection box for the tray that will contain the Universal paper.

## Loading the standard 250-sheet tray

The printer has two trays to select from: the standard tray (Tray 1), also known as the 250-sheet tray, and either the optional 250-sheet tray or the optional 550-sheet tray (Tray 2). Only one optional drawer (which includes an optional tray) may be attached to the printer at one time.

Proper paper loading prevents jams and facilitates trouble-free printing.

- 1 Pull the tray completely out.

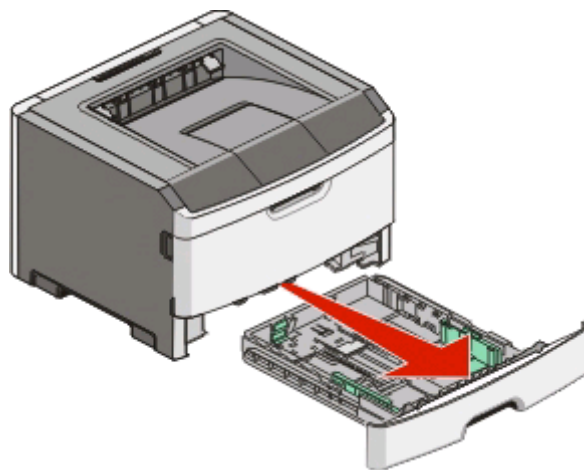

Do not remove trays while a job prints or when the Busy light sequence appears on the printer control panel. Doing so may cause a jam.

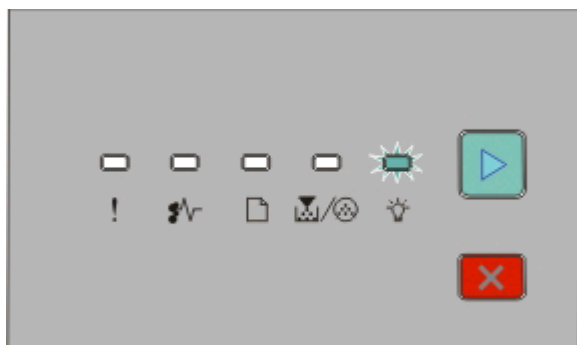

Busy

💡 - On

- 2 Squeeze the width guide tabs, and then slide them to the sides of the tray. The width guides move in unison.
- 3 Squeeze the length guide tabs together, and then slide the length guide to the correct position for the paper size being loaded.

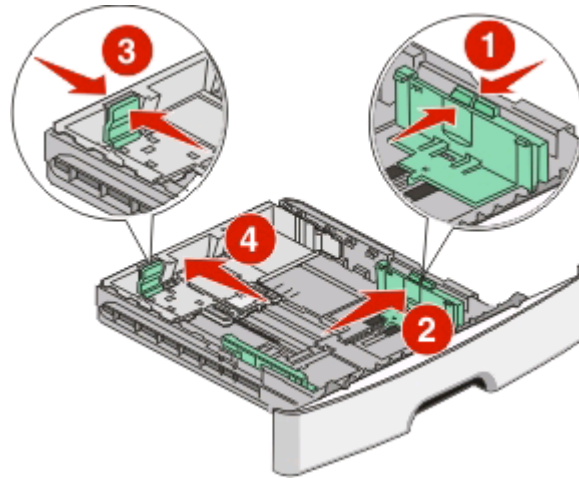

If you are loading a longer size of paper like A4 or legal, squeeze the length guide tabs and slide the length guide backwards to the position for the length of paper you are loading. The tray extends backwards.

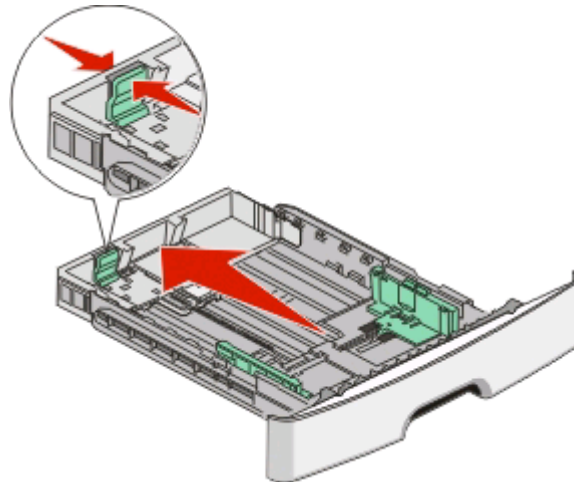

If you are loading A6-size paper:

- a Squeeze the length guide tabs together as shown, and slide the length guide toward the center of the tray to the A6 size position.
- b Raise the A6 length guide.

**Note:** The standard tray accommodates only 150 sheets of A6-size paper.

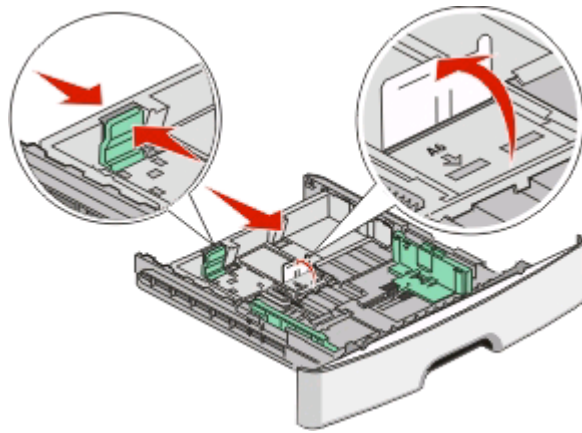

**4** Flex the sheets back and forth to loosen them, and then fan them. Do not fold or crease the paper. Straighten the edges on a level surface.



**5** Load the paper stack toward the back of the tray as shown with the recommended print side facedown.

**Note:** Notice the maximum fill line. Do not try to overload the tray. Do not load A6-size paper to the maximum fill line; the tray holds only 150 sheets of A6-size paper.

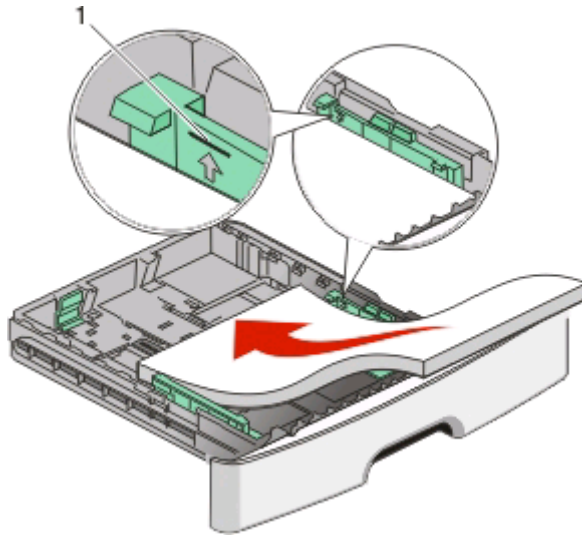

<b>1</b>	Maximum fill line
----------	-------------------

**Note:** When loading letterhead, place the top edge of the sheet toward the front of the tray. Load the letterhead with the design placed facedown.

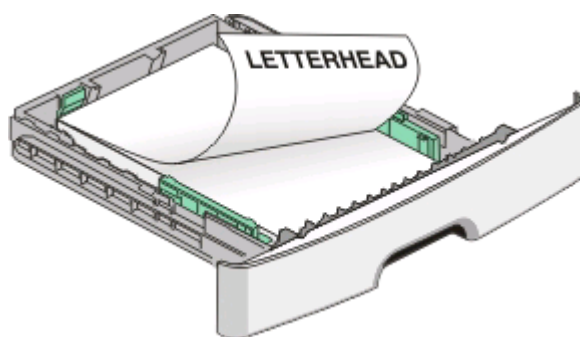

**6** Squeeze the width guide tabs on the right guide, and slide the width guides to lightly touch the side of the stack.

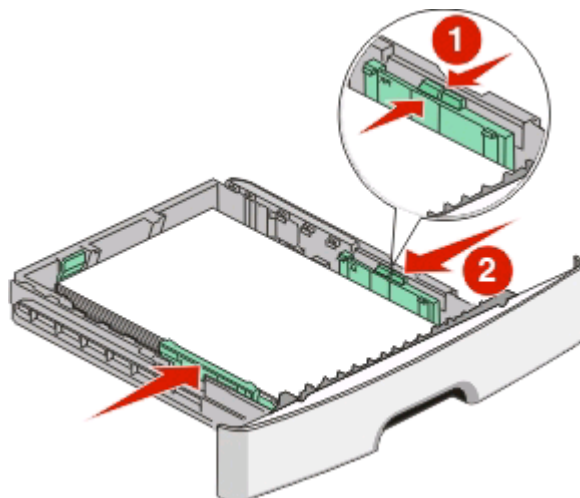

**7** Insert the tray.

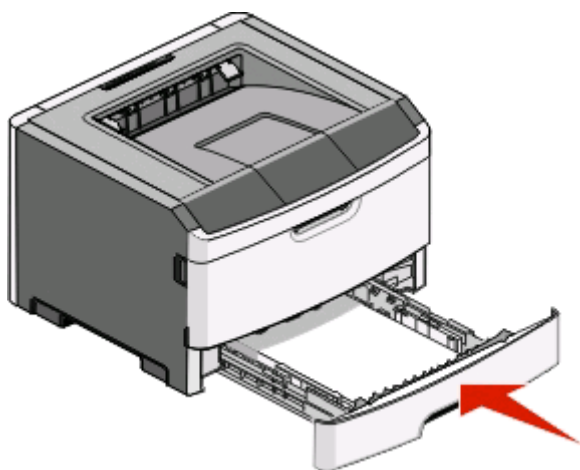

**8** If a different type of paper was loaded than the type previously loaded in the tray, change the Paper Type setting. For more information, see "Setting the paper size and paper type" on page 40.

**Note:** The difference between the standard 250-sheet tray and the optional 250- and 550-sheet trays is that the standard tray accommodates up to 150 sheets of A6-size paper, so the width guides slide farther to the center of the tray.

# Loading the optional 250- or 550-sheet tray

Only one optional drawer, which includes either a 250- or 550-sheet tray, may be attached to the printer at a time. Regardless of the number of sheets in the optional tray, it is referred to as Tray 2.

- 1 Pull the tray completely out.

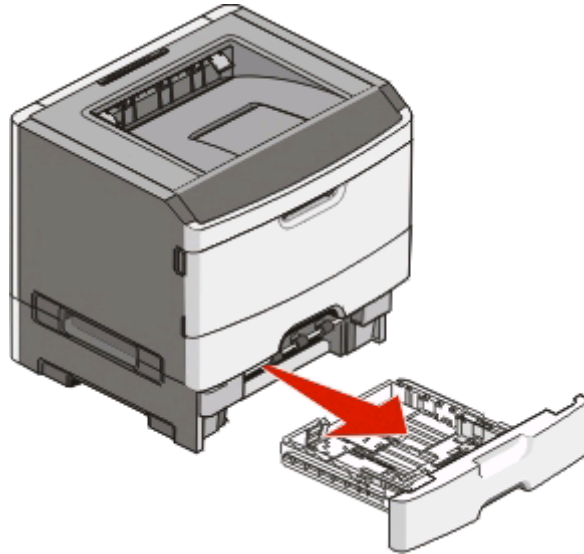

- 2 See "Loading the standard 250-sheet tray" on page 41 to complete the steps for loading a tray. An optional tray is loaded in the same way that the standard tray is loaded.

- 3 Insert the tray.

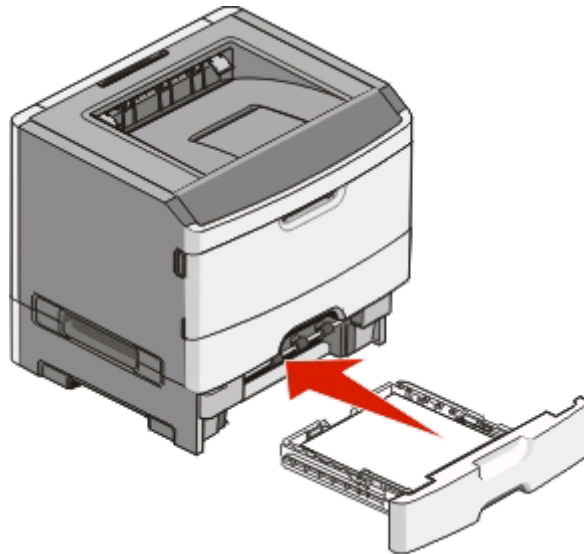

# Using the manual feeder

The manual feeder is located inside the manual feeder door of the printer and can feed only one sheet of paper at a time. You can use the manual feeder to quickly print on paper types or sizes that are not currently loaded in the tray.

- 1 Open the manual feeder door.

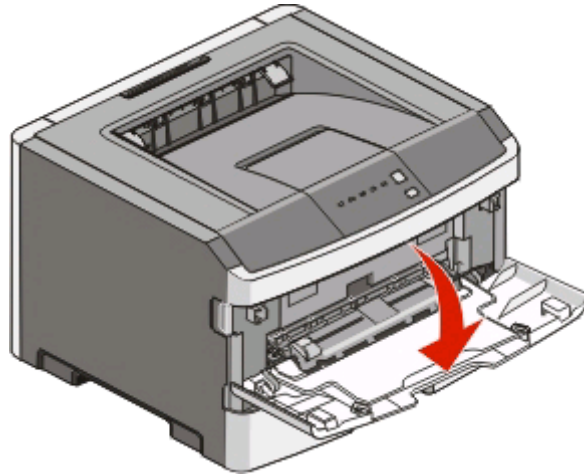

- 2 When the  light is lit, load the paper faceup into the center of the manual feeder.

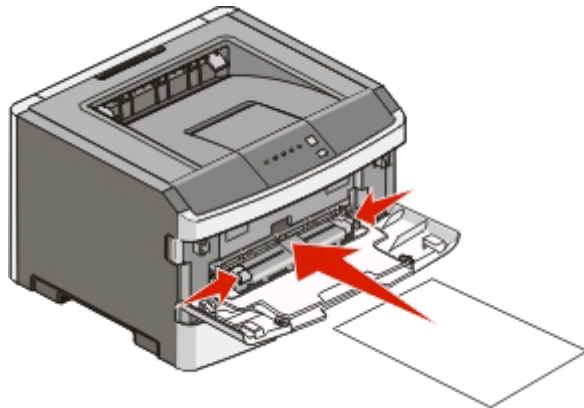

**Notes:**

- Load letterhead faceup, with the top of the sheet entering first.
- Load envelopes with the flap side down and with the stamp area as shown.

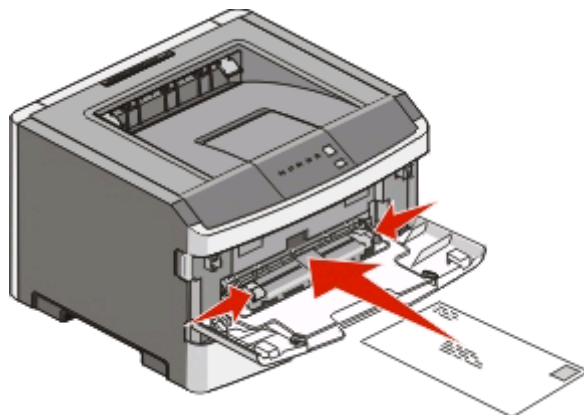

- 3 Feed paper into the manual feeder only to the point where its leading edge can contact the paper guides.
- 4 Adjust the paper guides to the paper width.

**Warning—Potential Damage:** Do not force the paper into the feeder. Forcing the paper causes jams.

## Using the standard exit bin and paper stop

The standard exit bin holds up to 150 sheets of 20 lb paper. It collects print jobs facedown. The standard exit bin includes a paper stop that keeps paper from sliding out the front of the bin as it stacks. The paper stop also aids in neater stacking of the paper.

To open the paper stop, pull it so it flips forward.

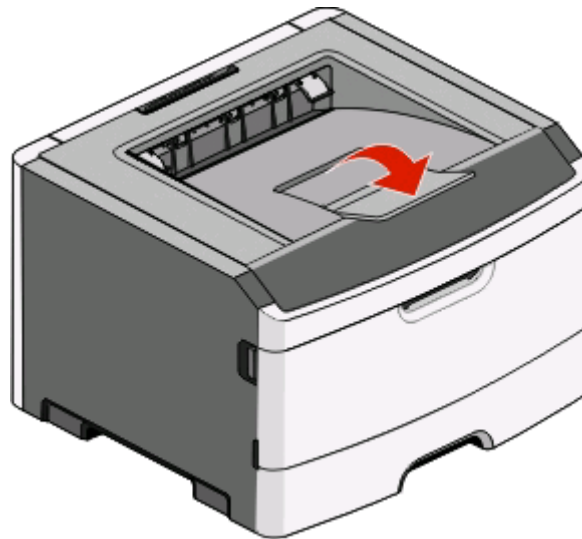

**Notes:**

- Do not leave the paper stop in the open position if you are printing on transparencies. Doing so may cause creases in the transparencies.
- When moving the printer to another location, make sure the paper stop is closed.

## Paper capacities

The capacities of the trays and the manual feeder are based on 75 g/m<sup>2</sup> (20 lb) paper.

Load up to	Notes
<p><b>Tray 1</b></p> <ul style="list-style-type: none"> <li>250 sheets of paper</li> <li>150 sheets of A6-size paper</li> <li>50 paper labels</li> <li>50 transparencies</li> </ul>	<p><b>Note:</b> Vinyl, pharmacy, or dual-sided labels are not supported. Use paper labels only.</p>

Load up to	Notes
<p><b>Tray 2</b></p> <ul style="list-style-type: none"> <li>250 or 550 sheets of paper</li> <li>50 paper labels</li> </ul>	<p><b>Notes:</b></p> <ul style="list-style-type: none"> <li>• Only one optional drawer may be installed on the printer at a time. The maximum amount of paper that can be loaded depends on whether you have an optional 250- or 550-sheet tray.</li> <li>• Vinyl, pharmacy, or dual-sided labels are not supported. Use paper labels only.</li> </ul>
<p><b>Manual feeder</b></p> <ul style="list-style-type: none"> <li>1 sheet of paper</li> <li>1 sheet of A6-size paper</li> <li>1 transparency</li> <li>1 sheet of card stock</li> <li>1 envelope</li> </ul>	<p><b>Note:</b> Feed paper into the manual feeder only to the point where its leading edge can contact the paper guides. Do not force the paper into the feeder.</p>

## Linking and unlinking trays

### Linking trays

Tray linking is useful for large print jobs or multiple copies. When one linked tray is empty, paper feeds from the next linked tray. When the Size and Type settings are the same for any trays, the trays are automatically linked. The Size and Type settings for all trays must be set from the Paper menu.

To initiate tray linking from a networked printer, access the Embedded Web Server:

- 1 Type the printer IP address into the address field of your Web browser.

**Note:** If you do not know the IP address of the printer, print a network setup page and locate the IP address in the TCP/IP section.

- 2 Click the **Settings** tab.
- 3 Under the Paper Menu, find the Size and Type for each tray.
- 4 Make sure the sizes and types of paper are the same under each tray to be linked.
- 5 Click **Submit**.

To initiate tray linking from a locally connected printer:

- On a Windows computer, access the Paper menu through the Local Printer Settings Utility.
- On a Macintosh computer, access the Paper menu through the Printer Settings.



## Unlinking trays

Unlinked trays have settings that are *not* the same as the settings of any other tray. To unlink a tray using the Paper menu, change the Paper Type and Paper Size settings of that tray so that they do not match the settings of any other tray.

- To unlink trays from a networked printer:
  - 1 Access the Embedded Web Server by typing the printer IP address into the address field of your Web browser.  
**Note:** If you do not know the IP address of the printer, then print a network setup page and locate the IP address in the TCP/IP section.
  - 2 Click **Settings**.
  - 3 Under the Paper Menu, find the Type and Size for each tray.
  - 4 Examine the Paper Type (for example: Plain Paper, Letterhead, Custom Type <x>). If the name that best describes your paper is used by linked trays, assign a different Paper Type name to the tray, such as Custom Type <x>, or assign your own custom name.
  - 5 Determine whether to change the Paper Size (for example: letter, A4, statement), making sure the Paper Size is not the same for any other tray.  
**Note:** Paper Size settings are not automatic; they must be set manually from the Paper Menu.
- To unlink trays from a locally connected printer, do one of the following:
  - On a Windows computer, access the Paper menu through the Local Printer Settings Utility. Then, change the Paper Type and Paper Size settings of the tray so that they do not match the settings of any other tray.
  - On a Macintosh computer, access the Paper menu through the Printer Settings. Then, change the Paper Type and Paper Size settings of the tray so that they do not match the settings of any other tray.

**Warning—Potential Damage:** Do not assign a Paper Type name that does not accurately describe the type of paper loaded in the tray. The temperature of the fuser varies according to the specified Paper Type. Paper may not be properly processed if an inaccurate Paper Type is selected.

## Assigning a Custom Type <x> name

Assigning a Custom Type <x> name to a tray enables you to link or unlink it. Use the same Custom Type <x> name for each tray that you want to link. Only trays with the same custom names assigned will link.

- 1 Do one of the following:
  - If the printer is on a network, open the Embedded Web Server by typing the printer IP address into the address field of your Web browser.  
**Note:** If you do not know the IP address of the printer, then print a network setup page and locate the IP address in the TCP/IP section.
  - If the printer is connected to a computer by a USB or parallel cable, open the Local Printer Settings Utility for Windows or Printer Settings for Macintosh. One of these utilities installs with the printer software.
- 2 Click **Settings**, and then click **Paper Menu**.
- 3 Click **Custom Name**, and then enter the name for the paper.
- 4 Click **Submit**.
- 5 Select a Custom Type

**6** Verify that the correct Paper Type is associated with the custom name.

**Note:** Plain Paper is the factory default Paper Type associated with all Custom Type <x> names and user-defined custom names.

**7** Click **Submit**.

## Changing a Custom Type <x> name

If the printer is on a network, you can use the Embedded Web Server to define a name other than Custom Type <x> for each of the custom paper types that are loaded. When a Custom Type <x> name is changed, the menus display the new name instead of Custom Type <x>.

To change a Custom Type <x> name:

**1** Type the printer IP address into the address field of your Web browser.

**Note:** If you do not know the IP address of the printer, print a network setup page and locate the address in the TCP/IP section.

**2** Click **Settings**.

**3** Click **Paper Menu**.

**4** Click **Custom Name**.

**5** Type a name for the paper type in a Custom Name <x> box.

**Note:** This custom name will replace a custom type <x> name under the Custom Types and Paper Size and Type menus.

**6** Click **Submit**.

**7** Click **Custom Types**.

**Custom Types** appears, followed by your custom name.

**8** Select a Paper Type setting from the pick list next to your custom name.

**9** Click **Submit**.

# Paper and specialty media guide

## Paper guidelines

### Paper characteristics

The following paper characteristics affect print quality and reliability. Consider these characteristics when evaluating new paper stock.

#### Weight

The printer trays can automatically feed paper weights up to 90 g/m<sup>2</sup> (24 lb bond) grain long paper. The manual feeder can automatically feed paper weights up to 163 g/m<sup>2</sup> (43 lb bond) grain long paper. Paper lighter than 60 g/m<sup>2</sup> (16 lb) might not be stiff enough to feed properly, causing jams. For best performance, use 75 g/m<sup>2</sup> (20 lb bond) grain long paper. For paper smaller than 182 x 257 mm (7.2 x 10.1 in.), we recommend 90 g/m<sup>2</sup> (24 lb) or heavier paper.

**Note:** Duplex printing is supported only for 60–90 g/m<sup>2</sup> (16–24 lb bond) paper.

#### Curl

Curl is the tendency for paper to curl at its edges. Excessive curl can cause paper feeding problems. Curl can occur after the paper passes through the printer, where it is exposed to high temperatures. Storing paper unwrapped in hot, humid, cold, or dry conditions, even in the trays, can contribute to paper curling prior to printing and can cause feeding problems.

#### Smoothness

Paper smoothness directly affects print quality. If paper is too rough, toner cannot fuse to it properly. If paper is too smooth, it can cause paper feeding or print quality issues. Always use paper between 100–300 Sheffield points; smoothness between 150–250 Sheffield points produces the best print quality.

#### Moisture content

The amount of moisture in paper affects both print quality and the ability of the printer to feed the paper correctly. Leave paper in its original wrapper until it is time to use it. This limits the exposure of paper to moisture changes that can degrade its performance.

Condition paper before printing by storing it in its original wrapper in the same environment as the printer for 24 to 48 hours before printing. Extend the time several days if the storage or transportation environment is very different from the printer environment. Thick paper may also require a longer conditioning period.

#### Grain direction

Grain refers to the alignment of the paper fibers in a sheet of paper. Grain is either *grain long*, running the length of the paper, or *grain short*, running the width of the paper.

For 60–90 g/m<sup>2</sup> (16–24 lb bond) paper, grain long paper is recommended.

## Fiber content

Most high-quality xerographic paper is made from 100% chemically treated pulped wood. This content provides the paper with a high degree of stability resulting in fewer paper feeding problems and better print quality. Paper containing fibers such as cotton can negatively affect paper handling.

## Unacceptable paper

The following paper types are not recommended for use with the printer:

- Chemically treated papers used to make copies without carbon paper, also known as carbonless papers, carbonless copy paper (CCP), or no carbon required (NCR) paper
- Preprinted papers with chemicals that may contaminate the printer
- Preprinted papers that can be affected by the temperature in the printer fuser
- Preprinted papers that require a registration (the precise print location on the page) greater than  $\pm 2.3$  mm ( $\pm 0.9$  in.), such as optical character recognition (OCR) forms

In some cases, registration can be adjusted with a software application to successfully print on these forms.

- Coated papers (erasable bond), synthetic papers, thermal papers
- Rough-edged, rough or heavily textured surface papers, or curled papers
- Recycled papers that fail EN12281:2002 (European)
- Paper weighing less than  $60 \text{ g/m}^2$  (16 lb)
- Multiple-part forms or documents

## Selecting paper

Using appropriate paper prevents jams and helps ensure trouble-free printing.

To help avoid jams and poor print quality:

- *Always* use new, undamaged paper.
- Before loading paper, know the recommended print side of the paper. This information is usually indicated on the paper package.
- *Do not* use paper that has been cut or trimmed by hand.
- *Do not* mix paper sizes, types, or weights in the same source; mixing results in jams.
- *Do not* use coated papers unless they are specifically designed for electrophotographic printing.

## Selecting preprinted forms and letterhead

Use these guidelines when selecting preprinted forms and letterhead:

- Use grain long for  $60$  to  $90 \text{ g/m}^2$  weight paper.
- Use only forms and letterhead printed using an offset lithographic or engraved printing process.
- Avoid papers with rough or heavily textured surfaces.

Use papers printed with heat-resistant inks designed for use in xerographic copiers. The ink must be able to withstand temperatures up to  $230^\circ\text{C}$  ( $446^\circ\text{F}$ ) without melting or releasing hazardous emissions. Use inks that are not affected by the resin in toner. Inks that are oxidation-set or oil-based generally meet these requirements; latex inks might not. When in doubt, contact the paper supplier.

Preprinted papers such as letterhead must be able to withstand temperatures up to  $230^\circ\text{C}$  ( $446^\circ\text{F}$ ) without melting or releasing hazardous emissions.

## Using recycled paper and other office papers

As an environmentally conscious company, Lexmark supports the use of recycled office paper produced specifically for use in laser (electrophotographic) printers. In 1998, Lexmark presented to the US government a study demonstrating that recycled paper produced by major mills in the US fed as well as non-recycled paper. However, no blanket statement can be made that *all* recycled paper will feed well.

Lexmark consistently tests its printers with recycled paper (20–100% post-consumer waste) and a variety of test paper from around the world, using chamber tests for different temperature and humidity conditions. Lexmark has found no reason to discourage the use of today's recycled office papers, but generally the following property guidelines apply to recycled paper.

- Low moisture content (4–5%)
- Suitable smoothness (100–200 Sheffield units, or 140–350 Bendtsen units, European)

**Note:** Some much smoother papers (such as premium 24 lb laser papers, 50–90 Sheffield units) and much rougher papers (such as premium cotton papers, 200–300 Sheffield units) have been engineered to work very well in laser printers, despite surface texture. Before using these types of paper, consult your paper supplier.

- Suitable sheet-to-sheet coefficient of friction (0.4–0.6)
- Sufficient bending resistance in the direction of feed

Recycled paper, paper of lower weight (<60 g/m<sup>2</sup> [16 lb bond]) and/or lower caliper (<3.8 mils [0.1 mm]), and paper that is cut grain-short for portrait (or short-edge) fed printers may have lower bending resistance than is required for reliable paper feeding. Before using these types of paper for laser (electrophotographic) printing, consult your paper supplier. Remember that these are general guidelines only and that paper meeting these guidelines may still cause paper feeding problems in any laser printer (for example, if the paper curls excessively under normal printing conditions).

## Storing paper

Use these paper storage guidelines to help avoid jams and uneven print quality:

- For best results, store paper where the temperature is 21°C (70°F) and the relative humidity is 40%. Most label manufacturers recommend printing in a temperature range of 18 to 24°C (65 to 75°F) with relative humidity between 40 and 60%.
- Store paper in cartons when possible, on a pallet or shelf, rather than on the floor.
- Store individual packages on a flat surface.
- Do not store anything on top of individual paper packages.

# Supported paper sizes, types, and weights

The following tables provide information on standard and optional paper sources and the types of paper they support.

**Note:** For an unlisted paper size, select the closest *larger* listed size.

For information on card stock and labels, see the *Card Stock & Label Guide*.

## Paper types and weights supported by the printer

The printer engine and the duplex path support 60–90 g/m<sup>2</sup> (16–24 lb) paper weights. The manual feeder supports 60–163 g/m<sup>2</sup> (16–43 lb) paper weights.

Paper type	250-sheet standard tray	250- or 550-sheet optional tray	Manual feeder	Duplex path
<b>Paper</b>	✓	✓	✓	✓
<ul style="list-style-type: none"> <li>• Plain</li> <li>• Light</li> <li>• Heavy</li> <li>• Rough/Cotton</li> <li>• Recycled</li> <li>• Custom</li> </ul>				
<b>Bond</b>	✓	✓	✓	✓
<b>Letterhead</b>	✓	✓	✓	✓
<b>Preprinted</b>	✓	✓	✓	✓
<b>Colored Paper</b>	✓	✓	✓	✓
<b>Card stock</b>	X	X	✓	X
<b>Glossy paper</b>	X	X	X	X
<b>Paper labels<sup>1</sup></b>	✓	✓	✓	X
<b>Transparencies</b>	✓	X	✓	X
<b>Envelopes (smooth)<sup>2</sup></b>	X	X	✓	X

<sup>1</sup> Single-sided paper labels are supported for occasional use. It is recommended to print 20 or fewer pages of paper labels a month. Vinyl, pharmacy, and dual-sided labels are not supported.

<sup>2</sup> Use envelopes that lie flat when individually placed on a table facedown.

## Paper sizes supported by the printer

Paper size	Dimensions	Standard 250-sheet tray	Optional 250- or 550-sheet tray	Manual feeder	Duplex path
<b>A4</b>	210 x 297 mm (8.3 x 11.7 in.)	✓	✓	✓	✓
<b>A5</b>	148 x 210 mm (5.8 x 8.3 in.)	✓	✓	✓	<b>X</b>
<b>A6<sup>1</sup></b>	105 x 148 mm (4.1 x 5.8 in.)	✓	<b>X</b>	✓	<b>X</b>
<b>Executive</b>	184 x 267 mm (7.3 x 10.5 in.)	✓	✓	✓	<b>X</b>
<b>Folio</b>	216 x 330 mm (8.5 x 13 in.)	✓	✓	✓	✓
<b>JIS B5</b>	182 x 257 mm (7.2 x 10.1 in.)	✓	✓	✓	<b>X</b>
<b>Legal</b>	216 x 356 mm (8.5 x 14 in.)	✓	✓	✓	✓
<b>Letter</b>	216 x 279 mm (8.5 x 11 in.)	✓	✓	✓	✓
<b>Oficio (Mexico)<sup>2</sup></b>	216 x 340 mm (8.5 x 13.4 in.)	✓	✓	✓	✓
<b>Statement</b>	140 x 216 mm (5.5 x 8.5 in.)	✓	✓	✓	<b>X</b>
<b>Universal<sup>3</sup></b>	76.2 x 127 mm (3 x 5 in.) up to 216 x 356 mm (8.5 x 14 in.)	✓	✓	✓	<b>X</b>
<b>B5 Envelope</b>	176 x 250 mm (6.9 x 9.8 in.)	<b>X</b>	<b>X</b>	✓	<b>X</b>
<b>C5 Envelope</b>	162 x 229 mm (6.4 x 9 in.)	<b>X</b>	<b>X</b>	✓	<b>X</b>
<b>DL Envelope</b>	110 x 220 mm (4.3 x 8.7 in.)	<b>X</b>	<b>X</b>	✓	<b>X</b>
<b>7 3/4 Envelope (Monarch)</b>	98 x 191 mm (3.9 x 7.5 in.)	<b>X</b>	<b>X</b>	✓	<b>X</b>
<b>9 Envelope</b>	98 x 225 mm (3.9 x 8.9 in.)	<b>X</b>	<b>X</b>	✓	<b>X</b>

<sup>1</sup> A6 is supported only for grain long papers.

<sup>2</sup> This size setting formats the page for 216 x 356 mm (8.5 x 14 in.) unless the size is specified by the software application.

<sup>3</sup> If a paper size you want to use is not listed, configure a Universal paper size. For more information, see "Configuring Universal paper settings" on page 40.

Paper size	Dimensions	Standard 250-sheet tray	Optional 250- or 550-sheet tray	Manual feeder	Duplex path
<b>10 Envelope</b>	105 x 241 mm (4.1 x 9.5 in.)	<b>X</b>	<b>X</b>	✓	<b>X</b>
<b>Other Envelope</b>	229 x 356 mm (9 x 14 in.)	<b>X</b>	<b>X</b>	✓	<b>X</b>

<sup>1</sup> A6 is supported only for grain long papers.

<sup>2</sup> This size setting formats the page for 216 x 356 mm (8.5 x 14 in.) unless the size is specified by the software application.

<sup>3</sup> If a paper size you want to use is not listed, configure a Universal paper size. For more information, see “Configuring Universal paper settings” on page 40.



# Printing

This chapter covers printing, printer reports, and job cancellation. Selection and handling of paper and specialty media can affect how reliably documents print. For more information, see “Avoiding jams” on page 113 and “Storing paper” on page 53.

## Printing a document

- 1 Load paper into a tray or feeder.
- 2 From the Paper menu, set the Paper Type and Paper Size based on the paper that is loaded.
- 3 Do one of the following:

### For Windows users

- a With a document open, click **File** → **Print**.
- b Click **Properties**, **Preferences**, **Options**, or **Setup**.
- c From the Form Source list box, select the source containing the paper you loaded.
- d From the Form Type list box, select the paper type.
- e From the Form Size list box, select the paper size.
- f Click **OK**, and then click **Print**.

### For Macintosh users

In Mac OS X:

- a Customize the settings as needed in the Page Setup dialog.
  - 1 With a document open, choose **File** > **Page Setup**.
  - 2 From the Paper Size pop-up menu, choose a paper size or create a custom size to match the loaded paper.
  - 3 Click **OK**.
- b Customize the settings as needed in the Print dialog:
  - 1 With a document open, click **File** > **Print**.  
If necessary, click the disclosure triangle to see more options.
  - 2 From the print options or Copies & Pages pop-up menu, choose **Printer Features**.
  - 3 From the Feature Sets pop-up menu, choose **Paper**.
  - 4 From the Paper type pop-up menu, choose a paper type.
  - 5 Click **Print**.

In Mac OS 9:

- a Customize the settings as needed in the Page Setup dialog:
  - 1 With a document open, choose **File** > **Page Setup**.
  - 2 From the Paper pop-up menu, choose a paper size or create a custom size to match the loaded paper.
  - 3 Click **OK**.

- b** Customize the settings as needed in the Print dialog:
  - 1** With a document open, choose **File > Print**.
  - 2** Select a Paper Source option, and then choose the tray loaded with the appropriate paper.
  - 3** Click **Print**.

## Printing on both sides of the paper

Some models of the printer have automatic duplex / 2-sided printing and other models have manual duplex / 2-sided printing.

### Printer models and printing on both sides of the paper

Use the table below to see whether your printer model will print on both sides of the paper automatically, or whether you should use the manual duplex method.

Model number	Duplex capability
E260	Manual duplex
E260d	Automatic duplex
E260dn	Automatic duplex

### Printing on both sides of the paper automatically

If your printer model has automatic 2-sided (duplex) printing, and you want to print two-sided pages for every print job, or for most print jobs, then select Duplex in the Finishing menu. To access the Finishing menu, do one of the following:

- If your printer is on a network, then type the printer IP address into the address field of your Web browser.
  - Note:** If you do not know the IP address of the printer, then print a network setup page and locate the IP address in the TCP/IP section.
- If the printer is connected to a computer by USB or parallel cable, then open the Local Printer Settings Utility for Windows or Printer Settings for Macintosh. One of these utilities installs with the printer software.
- For occasional two-sided printing, you can request two-sided printing in the printer software. Do one of the following, depending on your operating system:

#### For Windows users

- 1** With a document open, click **File → Print**.
- 2** Click **Properties, Preferences, Options, or Setup**.
- 3** Under the Page Layout tab, select **2-sided printing (duplex)**.
- 4** Select **Long edge** or **Short edge**.
- 5** Click **OK**.

#### For Macintosh users

- 1** With a document open, choose **File > Print**  
If necessary, click the disclosure triangle to see more options.
- 2** From the print options, Copies & Pages, or General pop-up menu, choose **Layout**.

- 3 From the Two-Sided pop-up menu, choose a duplex setting.
- 4 Click **Print**.



## Printing on both sides of the paper manually

If your printer does not have automatic two-sided (duplex) printing, and you want to print a duplex document, then you must use the manual duplexing method. This method involves printing the odd-numbered pages, and then flipping and reloading the stack of paper to print the even-numbered pages on the other side of the sheets.

- To duplex all print jobs, select Duplex in the Finishing menu. To access the Finishing menu, open the Local Printer Settings Utility for Windows or Printer Settings for Macintosh. One of these utilities installs with the printer software.
- To duplex a single print job, do one of the following:

### For Windows users

- 1 With a document open, click **File → Print**.
- 2 Click **Properties, Preferences, Options, or Setup**.
- 3 Under the Page Layout tab, select **2-sided printing (duplex)**.
- 4 Select **Long edge** or **Short edge**.
- 5 Click **Paper**.
- 6 Select the appropriate **Input options** for your print job.
- 7 Click **OK**.
- 8 Click **OK** on the Print window.

The printer prints every other page of the document first. Once the first side of your job prints, the  light comes on, and the  button light blinks.



 - On

 - Blinking

- 9 Load the paper back into the printer with the already-printed side up and the top of the page toward the front of the tray.

### For Macintosh users

- 1 With a document open, choose **File → Print**.
- 2 From the print options pop-up menu, choose **Paper Handling**.
- 3 From the “Pages to print” or Print menu, select to print the odd-numbered pages.
- 4 Click **Print**.

- 5 After printing the first set of pages, flip and reload the stack of printouts.
- 6 Repeat steps 1 and 2.
- 7 From the “Pages to print” or Print menu, select to print the even-numbered pages.
- 8 Click **Print**.

## Printing specialty documents

### Tips on using letterhead

Page orientation is important when printing on letterhead. Use the following table to determine which direction to load the letterhead:

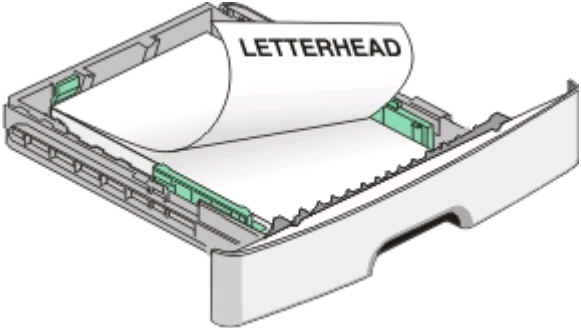
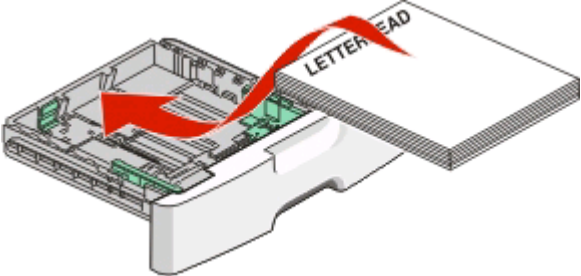
Source or process	Print side and paper orientation
<ul style="list-style-type: none"> <li>• Standard 250-sheet tray</li> <li>• Optional 250-sheet tray</li> <li>• Optional 550-sheet tray</li> </ul>	<p>Printed letterhead design is placed facedown. The top edge of the sheet with the logo is placed at the front of the tray.</p> 
<p>Duplex (two-sided) printing from trays</p>	<p>Printed letterhead design is placed faceup. The top edge of the sheet with the logo is placed at the front of the tray.</p> 
<p><b>Note:</b> Check with the manufacturer or vendor to determine whether the chosen preprinted letterhead is acceptable for laser printers.</p>	

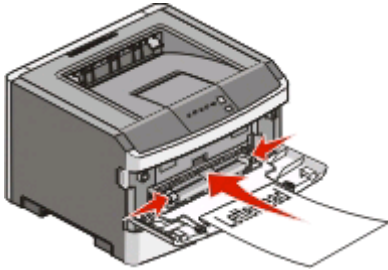
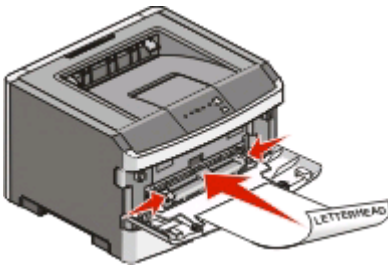
Source or process	Print side and paper orientation
Manual feeder (simplex printing)	<p>Preprinted letterhead design is placed faceup. The top edge of the sheet with the logo should enter the manual feeder first.</p> 
Manual feeder (duplex printing)	<p>Preprinted letterhead design is placed facedown. The top edge of the sheet with the logo should enter the manual feeder last.</p> 
<p><b>Note:</b> Check with the manufacturer or vendor to determine whether the chosen preprinted letterhead is acceptable for laser printers.</p>	

## Tips on using transparencies

Print samples on the transparencies being considered for use before buying large quantities.

When printing on transparencies:

- Feed transparencies from the standard 250-sheet tray or the manual feeder.
- Use transparencies designed specifically for laser printers. Check with the manufacturer or vendor to ensure transparencies are able to withstand temperatures up to 175°C (350°F) without melting, discoloring, offsetting, or releasing hazardous emissions.

**Note:** Transparencies can be printed at a temperature up to 180° C (356° F) if Transparency Weight is set to Heavy and Transparency Texture is set to Rough. Select these settings in the Paper menu, using the Embedded Web Server, or a local utility.

- To prevent print quality problems, avoid getting fingerprints on the transparencies.
- Before loading transparencies, fan the stack to prevent sheets from sticking together.
- Before loading transparencies, fan the stack to prevent sheets from sticking together.
- We recommend Lexmark part number 70X7240 for letter-size transparencies and Lexmark part number 12A5010 for A4-size transparencies.

## Tips on using envelopes

Print samples on the envelopes being considered for use before buying large quantities.

When printing on envelopes:

- Use envelopes designed specifically for laser printers. Check with the manufacturer or vendor to ensure the envelopes can withstand temperatures up to 210°C (410°F) without sealing, wrinkling, curling excessively, or releasing hazardous emissions.
- For the best performance, use envelopes made from 90 g/m<sup>2</sup> (24 lb bond) paper. Use up to 105 g/m<sup>2</sup> (28 lb bond) weight for envelopes as long as the cotton content is 25% or less. All-cotton envelopes must not exceed 90 g/m<sup>2</sup> (24 lb bond) weight.
- Use only new envelopes.
- To optimize performance and minimize jams, do not use envelopes that:
  - Have excessive curl or twist
  - Are stuck together or damaged in any way
  - Have windows, holes, perforations, cutouts, or embossing
  - Have metal clasps, string ties, or folding bars
  - Have an interlocking design
  - Have postage stamps attached
  - Have any exposed adhesive when the flap is in the sealed or closed position
  - Have bent corners
  - Have rough, cockle, or laid finishes
- Adjust the width guides to fit the width of the envelopes.

**Note:** A combination of high humidity (over 60%) and the high printing temperature may wrinkle or seal envelopes.

## Tips on using labels

Print samples on the labels being considered for use before buying large quantities.

**Note:** Use only paper label sheets. Vinyl, pharmacy, and dual-sided labels are not supported.

For detailed information on label printing, characteristics, and design, see the *Card Stock & Label Guide* available on the Lexmark Web site at [www.lexmark.com/publications](http://www.lexmark.com/publications).

When printing on labels:

- Use labels designed specifically for laser printers. Check with the manufacturer or vendor to verify that:
  - The labels can withstand temperatures up to 210°C (410°F) without sealing, excessive curling, wrinkling, or releasing hazardous emissions.

**Note:** Labels can be printed at a higher fusing temperature up to 220°C (428°F) if Label Weight is set to Heavy. Select this setting using the Embedded Web Server, or from the printer control panel Paper menu.

  - Label adhesives, face sheet (printable stock), and topcoats can withstand up to 25 psi (172 kPa) pressure without delaminating, oozing around the edges, or releasing hazardous fumes.
- Do not use labels with slick backing material.
- Use full label sheets. Partial sheets may cause labels to peel off during printing, resulting in a jam. Partial sheets also contaminate the printer and the cartridge with adhesive, and could void the printer and cartridge warranties.
- Do not use labels with exposed adhesive.
- Do not print within 1 mm (0.04 in.) of the edge of the label, of the perforations, or between die-cuts of the label.
- Be sure adhesive backing does not reach to the sheet edge. Zone coating of the adhesive at least 1 mm (0.04 in.) away from edges is recommended. Adhesive material contaminates the printer and could void the warranty.

- If zone coating of the adhesive is not possible, remove a 1.6 mm (0.06 in.) strip on the leading and driver edge, and use a non-oozing adhesive.
- Portrait orientation works best, especially when printing bar codes.

## Tips on using card stock

Card stock is heavy, single-ply specialty media. Many of its variable characteristics, such as moisture content, thickness, and texture, can significantly impact print quality. Print samples on the card stock being considered for use before buying large quantities.

When printing on card stock:

- Make sure the Paper Type is Card Stock.
- Select the appropriate Paper Texture setting.
- Be aware that preprinting, perforation, and creasing may significantly affect the print quality and cause jams or other paper handling problems.
- Check with the manufacturer or vendor to ensure the card stock can withstand temperatures up to 210°C (410°F) without releasing hazardous emissions.
- Do not use preprinted card stock manufactured with chemicals that may contaminate the printer. Preprinting introduces semi-liquid and volatile components into the printer.
- Use grain short card stock when possible.

## Printing a booklet

- 1 Click the **Page Layout** tab.
- 2 Click **More Page Layout Options**.
- 3 Click **Booklet**.
- 4 Click **OK**.



### Notes:

- The booklet feature automatically enables 2-sided printing with short-edge control, so any 2-sided printing options must be set before selecting the booklet function. After Booklet is selected, the 2-sided printing options remain at the last setting used.
- Booklet options are unavailable if the duplex unit is installed on the printer but not added to the Installed Options.

## Printing information pages

### Printing the menu settings and network setup pages

Print the menu settings page to review the current menu settings and to verify printer options are installed correctly. The network setup page prints at the same time, showing the network settings of the printer and levels of supplies. To print the menu settings and the network setup pages:

- 1 Make sure the  light is on.
- 2 Press .

The menu settings and network setup pages print.

On the menu settings page:



- Under the Paper Menu, check what papers are listed under Custom Types.

On the network setup page:

- Under Device Information, verify the amount of memory installed is correct .
- Under Cartridge Information, check the amount of toner.
- Under PC Unit, see the status of the photoconductor kit .

## Printing the print quality test pages

Print the print quality test pages to isolate print quality problems.

- 1 Turn the printer off, and then open the front door.
- 2 Press and hold  while turning the printer on.
- 3 Release .
- 4 Close the front door. The home menu light sequence appears.

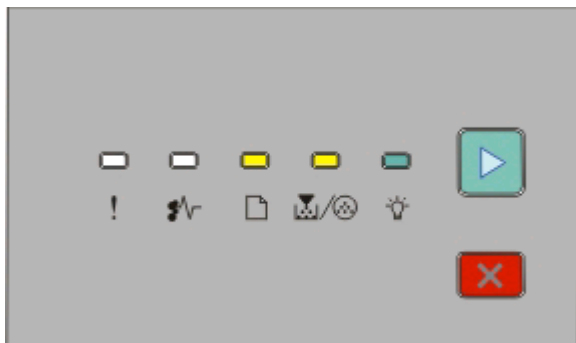



 - On

 /  - On

 - On

 - On

- 5 Press and release  until you see the light sequence for print quality test pages, as indicated on the printer settings configuration page.
- 6 Press and hold  until all the lights cycle.  
After a few minutes, the print quality test pages print. The pages include:
  - An information page that contains information about the printer, the toner cartridge, the margin settings, and the minimum stroke width, and a graphic for evaluating the print quality
  - Two pages to evaluate how well the printer is capable of printing various types of graphics
- 7 Examine the pages to determine the quality of printing. If there are problems, see “Solving print quality problems” on page 131.

To return to the home menu, press and hold  until all the lights cycle. To exit the menus, turn the printer off.



# Setting Jam Recovery

To ensure that a page will reprint after a paper jam, set Jam Recovery to Auto or On. To access Jam Recovery, do one of the following:



- Open the Embedded Web Server:
  - 1 Type the printer IP address into the address field of your Web browser.

**Note:** If you do not know the IP address of the printer, then print a network setup page and locate the IP address in the TCP/IP section.
  - 2 From the Settings screen, click **General Settings**, and then click **Print Recovery**.
  - 3 Click **Jam Recovery**, and then select **Auto** or **On**.
  - 4 Click **Submit**.
- If the printer is connected to a computer by a USB or parallel cable, open the Local Printer Settings Utility for Windows or Printer Settings for Macintosh. One of these utilities installs with your printer software. Under the Setup menu, make sure Jam Recovery is set to Auto or On.

## Canceling a print job

To cancel a print job, do one of the following:

### From the printer control panel

- 1 Press  to cancel the current print job.
- 2 Wait for the  light to appear before re-sending the print job.

### For Windows users

In Windows Vista:

- 1 Click .
- 2 Click **Control Panel**.
- 3 Click **Hardware and Sound**.
- 4 Click **Printers**.
- 5 Double-click the printer icon.
- 6 Select the job to cancel.
- 7 From the keyboard, press **Delete**.

In Windows XP:

- 1 Click **Start**.
- 2 From **Printers and Faxes**, double-click the printer icon.
- 3 Select the job to cancel.
- 4 From the keyboard, press **Delete**.

From the Windows taskbar:

When you send a job to print, a small printer icon appears in the right corner of the taskbar.

- 1 Double-click the printer icon.  
A list of print jobs appears in the printer window.
- 2 Select a job to cancel.
- 3 From the keyboard, press **Delete**.

## For Macintosh users

In Mac OS X version 10.5:

- 1 From the Apple menu, choose **System Preferences**.
- 2 Click **Print & Fax**, and then double-click the printer you are printing to.
- 3 From the printer window, select the job to cancel.
- 4 From the icon bar at the top of the window, click the **Delete** icon.

In Mac OS X versions 10.2 through 10.4:

- 1 Choose **Applications > Utilities**, and then double-click **Print Center** or **Printer Setup Utility**.
- 2 Double-click the printer icon.
- 3 From the printer window, select the job to cancel.
- 4 From the icon bar at the top of the window, click the **Delete** icon.

In Mac OS 9:

When you send a job to print, the printer icon for your selected printer appears on the desktop.

- 1 Double-click the printer icon.
- 2 From the printer window, select the job to cancel.
- 3 Click the trash icon.

# Understanding printer menus

A number of menus are available to make it easy for you to change printer settings. You may print a menus list by printing the menu settings and network setup pages. Access the menus from a networked printer by using the Embedded Web Server. From a printer connected by USB or parallel cable, access the menus by using the Local Printer Settings Utility for Windows or Printer Settings for Macintosh.

## Menus on the Embedded Web Server

The Embedded Web Server allows access to menus from a network printer. To open the Embedded Web Server:

- 1 Type the printer IP address into the address field of your Web browser.

**Note:** If you do not know the IP address of the printer, then print a network setup page and locate the IP address in the TCP/IP section.

- 2 Click one of the links to access the menus.

### Main menus under tabs of the Embedded Web Server

Device Status	Settings	Reports
<ul style="list-style-type: none"><li>• Toner Status</li><li>• Paper Input Tray(s)</li><li>• Paper Output Bin</li><li>• Device Type</li><li>• Speed</li><li>• Toner Cartridge Capacity</li><li>• PC Unit Life Remaining</li></ul>	<ul style="list-style-type: none"><li>• Default Settings<ul style="list-style-type: none"><li>– General Settings</li><li>– Print Settings</li><li>– Paper Settings</li></ul></li><li>• Other Settings<ul style="list-style-type: none"><li>– Network/Ports</li><li>– Update Firmware</li><li>– Security</li><li>– E-Mail Alert Setup</li><li>– Intervention Management</li></ul></li></ul>	<ul style="list-style-type: none"><li>• Device Statistics</li><li>• Device Settings</li><li>• Device Information</li><li>• Profiles List</li><li>• Printer Server Setup Page</li></ul>

- 3 Click **Settings**. The following menus are accessible:

#### Default Settings

General Settings  
Print Settings  
Paper Menu

#### Other Settings

Network/Ports  
Update Firmware  
Security  
E-mail Alert Setup  
Intervention Management

## Default Settings

### General Settings

Display Language  
Run Initial Setup  
Eco-Mode  
Quiet Mode  
Web Page Refresh Rate  
Asset Tag  
Contact Name  
Location  
Alarms  
Timeouts  
Print Recovery  
General Network Settings (Active Card)

### Print Settings

Finishing Menu  
Quality Menu  
Setup Menu  
PostScript Menu  
PCL Emul Menu  
Supply Notification

### Paper Menu

Default Source  
Paper Size/Type  
Paper Texture  
Paper Weight  
Paper Loading  
Custom Types  
Universal Setup

## Other Settings

### Network/Ports

TCP/IP  
IPv6  
SNMP  
Custom Link Setup  
General Network Settings (Active Card)  
Reset Print Server  
E-mail Server Setup  
Select Active Network Card  
Standard Network  
Standard USB  
Parallel

### Security

Web Page Password Protect  
Set Date and Time  
SNMP

## Using the Embedded Web Server

If the printer is installed on a network, the Embedded Web Server is available for a range of functions:

- Configuring printer settings
- Checking the status of the printer supplies
- Configuring network settings
- Creating a password for certain menus
- Viewing reports
- Restoring the factory default settings
- Viewing the virtual display

To access the Embedded Web Server:

- 1 Type the printer IP address into the address field of your Web browser.

**Note:** If you do not know the IP address of the printer, print a network setup page and locate the IP address in the TCP/IP section.

- 2 Click one of the tabs to access information about the printer, change settings, or view a report.

**Note:** If the printer is connected to a computer by a USB or parallel cable, open the Local Printer Settings Utility for Windows or Printer Settings for Macintosh to access printer menus.

## Installing the Local Printer Settings Utility

The Local Printer Settings Utility lets you change and save settings for a printer that is connected to a computer locally through a USB or parallel cable. After you install this utility, you can change settings of such controls as Toner Darkness, Power Saver, Paper Size, and Paper Type. Once selected, these settings apply to all print jobs, but you can use the printer software to change these settings for individual print jobs.

You can also save custom settings in a command file to distribute these settings to designated printers by using the **Save As Command File** option.

- 1 Insert the *Software and Documentation* CD.
- 2 Click **Install Printer and Software**.
- 3 Click **Agree** to accept the license agreement.
- 4 Select **Custom** installation, and then click **Next**.
- 5 Choose **Select Components** to install the utility on the computer instead of creating a script, and then click **Next**.
- 6 Select **Local** to install the utility on the computer you are currently using, and then click **Next**.
- 7 Under Tools, select **Local Printer Settings Utility**.
- 8 Click **Finish**.

### Notes:

- This utility is not supported in Windows x64 environments.
- This utility may not be included on this CD and/or may not be available for all printers.

## Using the Local Printer Settings Utility

The Local Printer Settings Utility lets you change and save printer settings for a printer connected locally through a USB or parallel cable. Save settings from the toolbar by clicking **Actions → Apply Settings**. You can also save your settings in a command file to distribute to designated printers by clicking **Actions → Save As Command File**.

The Local Printer Settings Utility contains the following menus and values:

- Paper
- Finishing
- Quality
- Setup

- PCL Emulation
- PostScript
- Parallel
- USB

Paper	Finishing	Quality	Setup
<ul style="list-style-type: none"> <li>• Paper Source</li> <li>• Paper Size</li> <li>• Paper Type</li> <li>• Custom Types</li> <li>• Substitute Size</li> <li>• Paper Texture</li> <li>• Paper Weight</li> </ul>	<ul style="list-style-type: none"> <li>• Duplex Binding</li> <li>• Copies</li> <li>• Blank Pages</li> <li>• Collation</li> <li>• Separator Sheets</li> <li>• Separator Source</li> <li>• Multipage (pages/side)</li> <li>• Multipage Ordering</li> <li>• Orientation</li> <li>• Multipage Border</li> </ul>	<ul style="list-style-type: none"> <li>• Print Resolution</li> <li>• Small Font Enhancer</li> <li>• Toner Darkness</li> <li>• Picture Grade</li> </ul>	<ul style="list-style-type: none"> <li>• Printer Language</li> <li>• Jam Recovery</li> <li>• Display Language</li> <li>• Print Area</li> <li>• Alarm Control</li> <li>• Toner Alarm</li> <li>• Download Target</li> <li>• Power Saver</li> <li>• Print Timeout</li> <li>• Auto Continue</li> <li>• Wait Timeout</li> <li>• Resolution Reduction</li> <li>• Resource Save</li> <li>• Reset Control</li> <li>• Print Buffer Control</li> <li>• Page Protect</li> <li>• Eco Mode</li> <li>• Quiet Mode</li> </ul>

PCL Emulation	PostScript	Parallel	USB
<ul style="list-style-type: none"> <li>• A4 Width</li> <li>• Orientation</li> <li>• Auto CR After LF</li> <li>• Auto LF after CR</li> <li>• Lines Per Page</li> </ul>	<ul style="list-style-type: none"> <li>• Print PS Error</li> <li>• Font Priority</li> </ul>	<ul style="list-style-type: none"> <li>• PCL SmartSwitch</li> <li>• PS SmartSwitch</li> <li>• Advanced Status</li> <li>• Honor Init</li> <li>• Protocol</li> <li>• Parallel Buffer</li> </ul>	<ul style="list-style-type: none"> <li>• PCL SmartSwitch</li> <li>• PS SmartSwitch</li> <li>• USB Buffer</li> </ul>

## Using the Finishing menu

Use the Finishing menu to adjust settings for such features as Collate, Separator Sheets, and N-up (Multipage) printing. You can use the settings to collate pages, to insert separator sheets between print jobs, and to print up to 16 images on a single page. To access the Finishing menu, do one of the following:

- If the printer is connected to a network, open the Embedded Web Server by typing the printer IP address into the address field of your Web browser. From the Settings tab, click **Print Settings**, and then click **Finishing Menu**.
- If the printer is connected to a computer by a USB or parallel cable, open the Local Printer Settings Utility for Windows or Printer Settings for Macintosh. One of these utilities installs with the printer software.

# Paper menu

## Default Source menu

Menu item	Description
<b>Default Source</b> Tray <x> Manual Paper Manual Env	Sets a default paper source for all print jobs <b>Notes:</b> <ul style="list-style-type: none"><li>• Tray 1 (standard tray) is the factory default setting.</li><li>• Only an installed paper source will appear as a menu setting.</li><li>• A paper source selected for a print job overrides the Default Source setting for the duration of the print job.</li><li>• If the same size and type of paper are in two trays and the Paper Size and Paper Type settings match, the trays are automatically linked. When one tray is empty, the job prints using paper from the linked tray.</li></ul>

## Size/Type menu

Menu item	Description
<b>Select Source menu</b> Tray 1 Tray 2 Manual Paper Manual Envelope	<b>Notes:</b> <ul style="list-style-type: none"><li>• These menus let you specify the installed paper size and type in the selected tray or manual feeder.</li><li>• Only installed trays and feeders are listed in this menu.</li></ul>
<b>Set Size menu for Tray 1 or Tray 2</b> A4 A5 A6 JIS B5 Executive Folio Legal Letter Oficio (Mexico) Statement Universal	Lets you specify the paper size loaded in each tray <b>Notes:</b> <ul style="list-style-type: none"><li>• Letter is the US factory default setting. A4 is the international factory default setting.</li><li>• If the same size and type of paper are in two trays and the Paper Size and Paper Type settings match, then the trays are automatically linked. When one tray is empty, the job prints using paper from the linked tray.</li><li>• The A6 paper size is supported only in Tray 1.</li></ul>

Menu item	Description
<p><b>Set Size menu for Manual Paper</b></p> <ul style="list-style-type: none"> <li>A4</li> <li>A5</li> <li>Executive</li> <li>Folio</li> <li>JIS B5</li> <li>Legal</li> <li>Letter</li> <li>Oficio (Mexico)</li> <li>Statement</li> <li>Universal</li> </ul>	<p>Lets you specify the size of the paper being loaded in the manual feeder</p> <p><b>Note:</b> Letter is the US factory default setting. A4 is the international factory default setting.</p>
<p><b>Set Size menu for Manual Envelope</b></p> <ul style="list-style-type: none"> <li>7 3/4 Envelope</li> <li>9 Envelope</li> <li>10 Envelope</li> <li>C5 Envelope</li> <li>B5 Envelope</li> <li>DL Envelope</li> <li>Other Envelope</li> </ul>	<p>Lets you specify the size of the envelope being manually loaded</p> <p><b>Note:</b> 10 Envelope is the US factory default setting. DL Envelope is the international factory default setting.</p>
<p><b>Set Type menu for Tray 1</b></p> <ul style="list-style-type: none"> <li>Plain Paper</li> <li>Card Stock</li> <li>Transparency</li> <li>Recycled</li> <li>Labels</li> <li>Bond</li> <li>Letterhead</li> <li>Preprinted</li> <li>Colored Paper</li> <li>Light Paper</li> <li>Heavy Paper</li> <li>Rough/Cotton</li> <li>Custom Type &lt;x&gt;</li> </ul>	<p>Lets you specify the type of paper loaded in Tray 1</p> <p><b>Notes:</b></p> <ul style="list-style-type: none"> <li>• Plain Paper is the factory default setting for Tray 1.</li> <li>• If available, a user-defined name will appear instead of Custom Type &lt;x&gt;.</li> <li>• Use this menu item to configure automatic tray linking.</li> </ul>



Menu item	Description
<p><b>Set Type menu for Tray 2</b></p> <ul style="list-style-type: none"> <li>Plain Paper</li> <li>Card Stock</li> <li>Recycled</li> <li>Labels</li> <li>Bond</li> <li>Letterhead</li> <li>Preprinted</li> <li>Colored Paper</li> <li>Light Paper</li> <li>Heavy Paper</li> <li>Rough/Cotton</li> <li>Custom Type &lt;x&gt;</li> </ul>	<p>Lets you specify the type of paper loaded in Tray 2</p> <p><b>Notes:</b></p> <ul style="list-style-type: none"> <li>• Custom Type &lt;x&gt; is the factory default setting.</li> <li>• If available, a user-defined name will appear instead of Custom Type &lt;x&gt;.</li> <li>• Use this menu item to configure automatic tray linking.</li> </ul>
<p><b>Set Type menu for Manual Paper</b></p> <ul style="list-style-type: none"> <li>Plain Paper</li> <li>Card Stock</li> <li>Transparency</li> <li>Labels</li> <li>Bond</li> <li>Letterhead</li> <li>Preprinted</li> <li>Colored Paper</li> <li>Light Paper</li> <li>Heavy Paper</li> <li>Rough/Cotton</li> <li>Custom Type &lt;x&gt;</li> </ul>	<p>Lets you specify the type of paper being manually loaded</p> <p><b>Note:</b> Plain Paper is the factory default setting.</p>
<p><b>Set Type menu for Manual Envelope</b></p> <ul style="list-style-type: none"> <li>Envelope</li> <li>Custom Type &lt;x&gt;</li> </ul>	<p>Lets you specify the type of envelope being manually loaded</p> <p><b>Note:</b> Envelope is the factory default setting.</p>

## Paper Texture menu

In the Paper Texture menu, the Select Type and Select Texture features work together to enable you to select the texture for a specific type of paper.

Menu item	Description
<b>Select Type</b> Plain Texture Card Stock Texture Transparency Texture Recycled Texture Labels Texture Bond Texture Envelope Texture Letterhead Texture Preprinted Texture Colored Texture Light Texture Heavy Texture Rough Texture Custom <x> Texture	Specifies the paper type
<b>Select Texture</b> Smooth Normal Rough	After you select a setting for Select Type, the Select Texture feature lets you set the texture for that type of media. <b>Notes:</b> <ul style="list-style-type: none"><li>• Normal is the factory default setting for most items.</li><li>• Rough is the factory default setting for Bond.</li><li>• When Rough Texture is the setting selected for Select Type, Rough is the only Select Texture setting available.</li><li>• Settings appear only if the paper is supported.</li></ul>

## Paper Weight menu

In the Paper Weight menu, the Select Type and Select Weight features work together to enable you to select the weight for a specific type of paper.

Menu item	Description
<b>Select Type</b> Plain Weight Card Stock Weight Transparency Weight Recycled Weight Labels Weight Bond Weight Envelope Weight Letterhead Weight Preprinted Weight Colored Weight Light Weight Heavy Weight Rough Weight Custom <x> Texture	Specifies the paper type
<b>Select Weight</b> Light Normal Heavy	After you select a setting for Select Type, the Select Weight feature lets you set the weight for that type of media.  <b>Notes:</b> <ul style="list-style-type: none"> <li>• Normal is the factory default setting for most items.</li> <li>• When Light Weight is the setting selected for Select Type, Light is the only Select Weight setting available.</li> <li>• When Heavy Weight is the setting selected for Select Type, Heavy is the only Select Weight setting available.</li> <li>• Settings appear only if the paper is supported.</li> </ul>

## Paper Loading menu

Menu item	Description
<b>Select Type</b> Recycled Loading Bond Loading Letterhead loading Preprinted Loading Colored Loading Light Loading Heavy Loading Custom Loading	Specifies the paper type  <b>Note:</b> After you select the type of paper, the Set Loading menu appears.

Menu item	Description
<b>Set Loading</b> <ul style="list-style-type: none"> <li>• Duplex</li> <li>• Off</li> </ul>	Specifies whether duplex (2-sided) printing is turned on <b>Note:</b> Off is the factory default setting.

## Custom Types menu

Menu item	Description
<b>Custom Type &lt;x&gt;</b> Paper Card Stock Transparency Labels Envelope Rough/Cotton	Name a <b>Custom Type &lt;x&gt;</b> , and this user-defined name displays instead of <b>Custom Type &lt;x&gt;</b> . <b>Notes:</b> <ul style="list-style-type: none"> <li>• The Custom Name must be limited to 16 characters.</li> <li>• Paper is the factory default setting for the Custom Type.</li> <li>• The custom media type must be supported by the selected tray or feeder in order for you to print from that source.</li> </ul>
<b>Recycled</b> Paper Card Stock Transparency Labels Envelope Rough/Cotton	Assign a paper type for the Recycled paper type loaded, and it will also be the Recycled paper type in other menus. <b>Notes:</b> <ul style="list-style-type: none"> <li>• Paper is the factory default setting.</li> <li>• The Recycled type must be supported by the selected tray or feeder in order for you to print from that source.</li> </ul>

## Universal Setup menu

These menu items are used to specify the height, width, and feed direction of the Universal Paper Size. The Universal Paper Size is a user-defined paper size. It is listed with the other paper size settings and includes similar options, such as support for duplex printing and printing multiple pages on one sheet.

Menu item	Description
<b>Units of Measure</b> Inches Millimeters	Identifies the units of measure <b>Notes:</b> <ul style="list-style-type: none"> <li>• Inches is the US factory default setting.</li> <li>• Millimeters is the international factory default setting.</li> </ul>
<b>Portrait Width</b> 3–14.17 inches 76–360 mm	Sets the portrait width <b>Notes:</b> <ul style="list-style-type: none"> <li>• If the width exceeds the maximum, then the printer uses the maximum width allowed.</li> <li>• 8.5 inches is the US factory default setting. Inches can be increased in 0.01-inch increments.</li> <li>• 216 mm is the international factory default setting. Millimeters can be increased in 1-mm increments.</li> </ul>

Menu item	Description
<b>Portrait Height</b> 3–14.17 inches 76–360 mm	Sets the portrait height <b>Notes:</b> <ul style="list-style-type: none"> <li>• If the height exceeds the maximum, then the printer uses the maximum height allowed.</li> <li>• 14 inches is the US factory default setting. Inches can be increased in 0.01-inch increments.</li> <li>• 356 mm is the international factory default setting. Millimeters can be increased in 1-mm increments.</li> </ul>
<b>Feed Direction</b> Short Edge Long Edge	Specifies the feed direction <b>Notes:</b> <ul style="list-style-type: none"> <li>• Short Edge is the factory default setting.</li> <li>• Long Edge appears only if the longest edge is shorter than the maximum length supported in the tray.</li> </ul>

## Settings menu

### General Settings menu

Menu item	Description
<b>Display Language</b> English Francais Deutsch Italiano Espanol Dansk Norsk Nederlands Svenska Portuguese Suomi Russian Polski Magyar Turkce Cesky Simplified Chinese Traditional Chinese Korean Japanese	Sets the language of the text appearing on the display <b>Note:</b> All languages may not be available for all printers.

Menu item	Description
<b>Eco-Mode</b> Off Energy Paper Energy/Paper	<b>Note:</b> Off is the factory default setting.
<b>Quiet Mode</b> Off On	<b>Note:</b> Off is the factory default setting.
<b>Run Initial Setup</b> Yes No	Before running the Setup Wizard, the default setting is Yes, but after running the wizard, the default setting is No.
<b>Alarm</b> Cartridge Alarm Off Single	The display shows a message when the toner is low <b>Notes:</b> <ul style="list-style-type: none"> <li>• Off is the factory default setting. The <b>Toner is low</b> message will appear as a warning.</li> <li>• Single means the <b>Toner is low</b> message will appear and the indicator light will blink red.</li> </ul>
<b>Timeouts</b> Power Saver Disabled 1–240	Sets the amount of time in minutes the printer waits after a job is printed before it goes into a reduced power state <b>Note:</b> Disabled does not appear unless Energy Conserve is Off.
<b>Timeouts</b> Print Timeout Disabled 1–255	Sets the amount of time in seconds the printer waits to receive an end-of-job message before canceling the remainder of the print job <b>Notes:</b> <ul style="list-style-type: none"> <li>• 90 seconds is the factory default setting.</li> <li>• When the timer expires, any partially printed page still in the printer is printed, and then the printer checks to see if any new print jobs are waiting.</li> <li>• Print Timeout is available only when using PCL. This setting has no effect on PostScript emulation print jobs.</li> </ul>
<b>Timeouts</b> Wait Timeout Disabled 15–65535	Sets the amount of time in seconds the printer waits for additional data before canceling a print job <b>Notes:</b> <ul style="list-style-type: none"> <li>• 40 seconds is the factory default setting.</li> <li>• Wait Timeout is available only when the printer is using PostScript emulation. This setting has no effect on PCL emulation print jobs.</li> </ul>

Menu item	Description
<b>Print Recovery</b> Auto Continue Disabled 5–255	Lets the printer automatically continue printing from certain offline situations when not resolved within the specified time period  <b>Notes:</b> <ul style="list-style-type: none"> <li>• Disabled is the factory default setting.</li> <li>• 5–255 is a range of time in seconds.</li> </ul>
<b>Print Recovery</b> Jam Recovery On Off Auto	Specifies whether the printer reprints jammed pages  <b>Notes:</b> <ul style="list-style-type: none"> <li>• Auto is the factory default setting. The printer reprints jammed pages unless the memory required to hold the pages is needed for other printer tasks.</li> <li>• On sets the printer to always reprint jammed pages.</li> <li>• Off sets the printer to never reprint jammed pages.</li> </ul>
<b>Print Recovery</b> Page Protect On Off	Lets the printer successfully print a page that may not have printed otherwise  <b>Notes:</b> <ul style="list-style-type: none"> <li>• Off is the factory default setting. Off prints a partial page when there is not enough memory to print the whole page.</li> <li>• On sets the printer to process the whole page so that the entire page prints.</li> </ul>
<b>Factory Defaults</b> Do Not Restore Restore Now	Returns the printer settings to the factory default settings  <b>Notes:</b> <ul style="list-style-type: none"> <li>• Do Not Restore is the factory default setting. Do Not Restore keeps the user-defined settings.</li> <li>• Restore Now returns all printer settings to the factory default settings except those in the Network/Ports menu. All downloads stored in RAM are deleted. Downloads stored in flash memory are not affected.</li> </ul>

## Setup menu

Menu item	Description
<b>Printer Language</b> PS Emulation PCL Emulation	Sets the default printer language  <b>Notes:</b> <ul style="list-style-type: none"> <li>• PostScript emulation uses a PS interpreter for processing print jobs. PCL emulation uses a PCL interpreter for processing print jobs.</li> <li>• The factory default printer language is PCL Emulation.</li> <li>• Setting a printer language as the default does not prevent a software program from sending print jobs that use another printer language.</li> </ul>

Menu item	Description
<b>Print Area</b> Normal Whole Page	Sets the logical and physical printable area <b>Notes:</b> <ul style="list-style-type: none"> <li>• Normal is the factory default setting. When attempting to print data in the non-printable area defined by the Normal setting, the printer clips the image at the boundary.</li> <li>• The Whole Page setting allows the image to be moved into the non-printable area defined by the Normal setting, but the printer will clip the image at the Normal setting boundary.</li> <li>• The Whole Page setting affects only pages printed using a PCL 5e interpreter. This setting has no effect on pages printed using the PCL XL or PostScript interpreter.</li> </ul>
<b>Download Target</b> RAM Flash	Sets the storage location for downloads <b>Notes:</b> <ul style="list-style-type: none"> <li>• RAM is the factory default setting.</li> <li>• Flash appears only if a flash option is installed.</li> <li>• Storing downloads in RAM is temporary.</li> </ul>
<b>Resource Save</b> On Off	Specifies how the printer handles temporary downloads, such as fonts and macros stored in RAM, when the printer receives a job that requires more memory than is available <b>Notes:</b> <ul style="list-style-type: none"> <li>• Off is the factory default setting. Off sets the printer to retain the downloads only until memory is needed. Downloads are deleted in order to process print jobs.</li> <li>• The On setting retains the downloads during language changes and printer resets. If the printer runs out of memory, downloads are not deleted.</li> </ul>
<b>Print All Order</b> Alphabetically Newest First Oldest First	Sets the order in which the print jobs are printed. <b>Note:</b> Alphabetically is the factory default setting.

## Finishing menu

Menu item	Description
<b>Sides (Duplex)</b> 2-sided 1-sided	Specifies whether duplex (2-sided) printing is set as the default for all print jobs <b>Notes:</b> <ul style="list-style-type: none"> <li>• 1-sided is the factory default setting.</li> <li>• To set 2-sided printing from the software program, for Windows users, click <b>File → Print</b>, and then click <b>Properties, Preferences, Options, or Setup</b>. For Macintosh users, choose <b>File &gt; Print</b>, and then adjust the settings from the print dialog and pop-up menus.</li> </ul>



Menu item	Description
<b>Duplex Binding</b> Long Edge Short Edge	Defines the way duplexed pages are bound and how the printing on the back of the page is oriented in relation to the printing on the front of the page <b>Notes:</b> <ul style="list-style-type: none"> <li>• Long Edge is the factory default setting.</li> <li>• Long Edge specifies that binding be placed on the left edge of portrait pages and the top edge of landscape pages.</li> <li>• Short Edge specifies that binding be placed on the top edge of portrait pages and the left edge of landscape pages.</li> </ul>
<b>Copies</b> 1–999	Specifies a default number of copies for each print job <b>Note:</b> 1 is the factory default setting.
<b>Blank Pages</b> Do Not Print Print	Specifies whether blank pages are inserted in a print job <b>Note:</b> Do Not Print is the factory default setting.
<b>Collate</b> Off (1,1,1,2,2,2) On (1,2,1,2,1,2)	Stacks the pages of a print job in sequence when printing multiple copies <b>Notes:</b> <ul style="list-style-type: none"> <li>• On is the factory default setting, so the pages will be printed sequentially.</li> <li>• Both settings print the entire job the same number of times.</li> </ul>
<b>Separator Sheets</b> None Between Copies Between Jobs Between Pages	Specifies whether blank separator sheets are inserted <b>Notes:</b> <ul style="list-style-type: none"> <li>• None is the factory default setting.</li> <li>• Between Copies inserts a blank sheet between each copy of a print job if Collate is On. If Collation is Off, a blank page is inserted between each set of printed pages, such as after all page 1s and after all page 2s.</li> <li>• Between Jobs inserts a blank sheet between print jobs.</li> <li>• Between Pages inserts a blank sheet between each page of the print job. This setting is useful when printing transparencies or inserting blank pages in a document for notes.</li> </ul>
<b>Separator Source</b> Tray <x> Multi-Purpose Feeder	Specifies the paper source for separator sheets <b>Notes:</b> <ul style="list-style-type: none"> <li>• Tray 1 (standard tray) is the factory default setting.</li> <li>• Multi-Purpose Feeder appears as a value only if it is a supported option on the printer and if Configure MP is set to Cassette.</li> </ul>
<b>N-up (pages-side)</b> Off 2-Up 3-Up 4-Up 6-Up 9-Up 12-Up 16-Up	Specifies that multiple-page images be printed on one side of a sheet of paper. <b>Notes:</b> <ul style="list-style-type: none"> <li>• Off is the factory default setting.</li> <li>• The number selected is the number of page images that will print per side.</li> </ul>

Menu item	Description
<b>N-up Ordering</b> Horizontal Reverse Horizontal Reverse Vertical Vertical	Specifies the positioning of multiple-page images when using N-up (pages-sides) <b>Notes:</b> <ul style="list-style-type: none"> <li>• Horizontal is the factory default setting.</li> <li>• Positioning depends on the number of images and whether the images are in portrait or landscape orientation.</li> </ul>
<b>Orientation</b> Auto Landscape Portrait	Specifies the orientation of a multiple-page sheet <b>Notes:</b> <ul style="list-style-type: none"> <li>• Auto is the factory default setting. The printer chooses between portrait and landscape.</li> <li>• Landscape uses long edge.</li> <li>• Portrait uses short edge.</li> </ul>
<b>N-up Border</b> None Solid	Prints a border around each page image when using N-up (pages-sides) <b>Note:</b> None is the factory default setting.

## Quality menu

Menu item	Description
<b>Print Resolution</b> 300 dpi 600 dpi 1200 dpi 1200 IQ 2400 IQ	Specifies the printed output resolution <b>Note:</b> 600 dpi is the factory default setting.
<b>Toner Darkness</b> 1–10	Lightens or darkens the printed output <b>Notes:</b> <ul style="list-style-type: none"> <li>• 8 is the factory default setting.</li> <li>• Selecting a smaller number can help conserve toner.</li> </ul>
<b>Enhance Fine Lines</b> On Off	Enables a print mode preferable for files such as architectural drawings, maps, electrical circuit diagrams, and flow charts <b>Notes:</b> <ul style="list-style-type: none"> <li>• Off is the factory default setting.</li> <li>• To set Enhance Fine Lines, with a document open, click <b>File → Print</b>, and then click <b>Properties, Preferences, Options, or Setup</b> for Windows users. For Macintosh users, choose <b>File&gt; Print</b>, and then adjust the settings from the print dialog and pop-up menus.</li> <li>• To set Enhance Fine Lines using the Embedded Web Server, type the network printer IP address in a browser window.</li> </ul>
<b>Gray Correction</b> Auto Off	Choose whether to apply Gray Correction on printed gray images. The Auto setting automatically applies Gray Correction and Off does not. <b>Note:</b> Off is the factory default setting.

Menu item	Description
<b>Pixel Boost</b> Off Fonts Horizontally Vertically Both directions	Choose whether to make characters more distinct and definite. Pixel Boost may be needed when using certain fonts. <b>Note:</b> Off is the factory default setting.
<b>Brightness</b> -6-6	Adjusts or darkens printed output and conserves toner <b>Note:</b> 0 is the factory default setting.
<b>Contrast</b> 0-5	Adjusts the contrast of printed objects <b>Note:</b> 0 is the factory default setting.

## PostScript menu

Menu item	Description
<b>Print PS Error</b> On Off	Prints a page containing the PostScript error <b>Note:</b> Off is the factory default setting.
<b>Font Priority</b> Resident Flash/Disk	Establishes the font search order <b>Notes:</b> <ul style="list-style-type: none"> <li>Resident is the factory default setting.</li> <li>A formatted flash memory option card must be installed in the printer and operating properly for this menu item to be available.</li> <li>The flash memory option cannot be Read/Write, Write, or password-protected.</li> <li>Job Buffer Size must not be set to 100%.</li> </ul>

## PCL Emul menu

Menu item	Description
<b>Font Source</b> Resident Download Flash All	Specifies the set of fonts available <b>Notes:</b> <ul style="list-style-type: none"> <li>Resident is the factory default setting. It shows the factory default set of fonts downloaded into RAM.</li> <li>Download appears only if downloaded fonts exist. It shows all the fonts downloaded into RAM.</li> <li>Flash appears only if a flash option containing fonts is installed.</li> <li>A flash option must be properly formatted and cannot be Read/Write, Write, or password protected.</li> <li>All shows all fonts available to any option.</li> </ul>
<b>Font Name</b> <x>	Lets you view or change the setting from a selection list

Menu item	Description
<b>Symbol Set</b> <x>	Lets you view or change the setting from a selection list
<b>PCL Emulation Settings</b> Point Size 1.00–1008.00	Changes the point size for scalable typographic fonts <b>Notes:</b> <ul style="list-style-type: none"> <li>• 12 is the factory default setting.</li> <li>• Point Size refers to the height of the characters in the font. One point equals approximately 1/72 of an inch.</li> <li>• Point sizes can be increased or decreased in 0.25-point increments.</li> </ul>
<b>PCL Emulation Settings</b> Pitch 0.08–100	Specifies the font pitch for scalable monospaced fonts <b>Notes:</b> <ul style="list-style-type: none"> <li>• 10 is the factory default setting.</li> <li>• Pitch refers to the number of fixed-space characters per inch (dpi).</li> <li>• Pitch can be increased or decreased in 0.01-dpi increments.</li> <li>• For nonscalable monospaced fonts, the pitch appears on the display but cannot be changed.</li> </ul>
<b>PCL Emulation Settings</b> Orientation Portrait Landscape	Specifies the orientation of text and graphics on the page <b>Notes:</b> <ul style="list-style-type: none"> <li>• Portrait is the factory default setting.</li> <li>• Portrait prints text and graphics parallel to the short edge of the page.</li> <li>• Landscape prints text and graphics parallel to the long edge of the page.</li> </ul>
<b>PCL Emulation Settings</b> Lines per Page 1–255 60 64	Specifies the number of lines that print on each page <b>Notes:</b> <ul style="list-style-type: none"> <li>• 60 is the US factory default setting. 64 is the international default setting.</li> <li>• The printer sets the amount of space between each line based on the Lines per Page, Paper Size, and Orientation settings. Select the desired Paper Size and Orientation before setting Lines per Page.</li> </ul>
<b>PCL Emulation Settings</b> A4 Width 198 mm 203 mm	Sets the printer to print on A4-size paper <b>Notes:</b> <ul style="list-style-type: none"> <li>• 198 mm is the factory default setting.</li> <li>• The 203-mm setting sets the width of the page to allow the printing of eighty 10-pitch characters.</li> </ul>
<b>PCL Emulation Settings</b> Auto CR after LF On Off	Specifies whether the printer automatically performs a carriage return (CR) after a line feed (LF) control command <b>Note:</b> Off is the factory default setting.
<b>PCL Emulation Settings</b> Auto LF after CR On Off	Specifies whether the printer automatically performs a line feed (LF) after a carriage return (CR) control command <b>Note:</b> Off is the factory default setting.

Menu item	Description
<b>Tray Renumber</b> Assign MP Feeder Off None 0–199 Assign Tray <x> Off None 0–199 Assign Manual Paper Off None 0–199 Assign Man Env Off None 0–199	Configures the printer to work with printer software or programs that use different source assignments for trays, drawers, and feeders  <b>Notes:</b> <ul style="list-style-type: none"> <li>• Off is the factory default setting.</li> <li>• None is not an available selection. It is displayed only when it is selected by the PCL 5 interpreter.</li> <li>• None ignores the Select Paper Feed command.</li> <li>• 0–199 allows a custom setting to be assigned.</li> </ul>
<b>Tray Renumber</b> View Factory Def None	Displays the factory default setting assigned to each tray, drawer, or feeder
<b>Tray Renumber</b> Restore Defaults Yes No	Returns all tray, drawer, and feeder assignments to the factory default settings

## Network/Ports menu

### Network menu

Menu item	Description
<b>PCL SmartSwitch</b> On Off	Sets the printer to automatically switch to PCL emulation when a print job requires it, regardless of the default printer language  <b>Notes:</b> <ul style="list-style-type: none"> <li>• On is the factory default setting.</li> <li>• When the Off setting is used, the printer does not examine incoming data.</li> <li>• When the Off setting is used, the printer uses PostScript emulation if PS SmartSwitch is set to On. It uses the default printer language specified in the Setup menu if PS SmartSwitch is set to Off.</li> </ul>

Menu item	Description
<b>PS SmartSwitch</b> On Off	Sets the printer to automatically switch to PS emulation when a print job requires it, regardless of the default printer language  <b>Notes:</b> <ul style="list-style-type: none"> <li>• On is the factory default setting.</li> <li>• When the Off setting is used, the printer does not examine incoming data.</li> <li>• When the Off setting is used, the printer uses PCL emulation if PCL SmartSwitch is set to On. It uses the default printer language specified in the Setup menu if PCL SmartSwitch is set to Off.</li> </ul>
<b>NPA Mode</b> Off Auto	Sets the printer to perform the special processing required for bidirectional communication following the conventions defined by the NPA protocol  <b>Notes:</b> <ul style="list-style-type: none"> <li>• Auto is the factory default setting.</li> <li>• Changing this setting from the printer control panel and then exiting the menus causes the printer to restart. The menu selection is updated.</li> </ul>
<b>Network Buffer</b> Disabled Auto 3K to <maximum size allowed>	Sets the size of the network input buffer  <b>Notes:</b> <ul style="list-style-type: none"> <li>• Auto is the factory default setting.</li> <li>• The value can be changed in 1K increments.</li> <li>• The maximum size allowed depends on the amount of memory in the printer, the size of the other link buffers, and whether Resource Save is set to On or Off.</li> <li>• To increase the maximum size range for the Network Buffer, disable or reduce the size of the parallel and USB buffers.</li> <li>• Changing this setting from the printer control panel and then exiting the menus causes the printer to restart. The menu selection is updated.</li> </ul>
<b>Mac Binary PS</b> On Off Auto	Sets the printer to process Macintosh binary PostScript print jobs  <b>Notes:</b> <ul style="list-style-type: none"> <li>• Auto is the factory default setting.</li> <li>• The Off setting filters print jobs using the standard protocol.</li> <li>• The On setting processes raw binary PostScript print jobs.</li> </ul>
<b>Network Setup</b>	Reflects the network setup for your printer

## Network Card menu

Menu item	Description
<b>View Card Status</b> Connected Disconnected	Allows you to ascertain whether the Network Card is connected.
<b>View Card Speed</b>	Reflects the speed of a currently active network card.

Menu item	Description
<b>View Network Address</b> UAA LAA	Both addresses are represented by 12-digit hexadecimal numbers.
<b>Job Timeout</b> 0-225 seconds	Sets the amount of time in seconds that a network print job can take before it is canceled.  <b>Notes:</b> <ul style="list-style-type: none"> <li>• 90 seconds is the factory default setting.</li> <li>• A setting value of 0 disables the timeout.</li> <li>• If a value of 1–9 is selected, the setting is saved as 10.</li> </ul>
<b>Banner Page</b> On Off	Allows the printer to print a banner page.  <b>Note:</b> Off is the factory default setting.

## TCP/IP menu

Use the following menu items to view or set the TCP/IP information.

**Note:** This menu is available only for network models or printers attached to print servers.

Menu item	Description
<b>TCP/IP</b> Activate On Off	Specifies whether to activate TCP/IP  <b>Note:</b> On is the factory default setting.
<b>TCP/IP</b> View Hostname	Shows the current TCP/IP hostname
<b>TCP/IP</b> IP Address	Lets you view or change the current TCP/IP Address information  <b>Note:</b> This is a four-field IP Address.
<b>TCP/IP</b> Netmask	Lets you view or change the current TCP/IP Netmask information  <b>Note:</b> This is a four-field IP Netmask.
<b>TCP/IP</b> Gateway	Lets you view or change the current TCP/IP Gateway information  <b>Note:</b> This is a four-field IP Gateway.
<b>TCP/IP</b> Enable DHCP Yes No	Lets you view or change the setting  <b>Note:</b> Yes is the factory default setting.
<b>TCP/IP</b> AutoIP Yes No	Lets you view or change the setting  <b>Note:</b> Yes is the factory default setting.

Menu item	Description
<b>TCP/IP</b> Enable FTP/TFTP Yes No	Lets you view or change the setting <b>Note:</b> Yes is the factory default setting.
<b>TCP/IP</b> Enable HTTP Server Yes No	Lets you view or change the setting <b>Note:</b> Yes is the factory default setting.
<b>TCP/IP</b> WINS Server Address DNS Server Address	Lets you view or change the setting <b>Note:</b> This is a four-field IP address.

## IPv6 menu

Use the following menu items to view or set the Internet Protocol version 6 (IPv6) information.

**Note:** This menu is available only for network models or printers attached to print servers.

Menu item	Description
<b>IPv6</b> Enable IPv6 On Off	Enables IPv6 in the printer <b>Note:</b> On is the factory default setting.
<b>IPv6</b> Auto Configuration On Off	Enables the network adapter to accept the automatic IPv6 address configuration entries provided by a router <b>Note:</b> On is the factory default setting.
<b>IPv6</b> View Hostname View Address View Router Address	Shows the setting <b>Note:</b> These settings can be changed only from the Embedded Web Server.
<b>IPv6</b> Enable DHCPv6 Yes No	Enables DHCPv6 in the printer <b>Note:</b> Yes is the factory default setting.

## AppleTalk menu

Menu item	Description
<b>Activate</b> Off On	Activates or deactivates AppleTalk support <b>Note:</b> On is the factory default setting.



Menu item	Description
<b>View Name</b> <none>	Shows the assigned AppleTalk name
<b>View Address</b> <none>	Shows the assigned AppleTalk address
<b>Set Zone</b> <list of zones available on the network>	Provides a list of AppleTalk zones available on the network <b>Note:</b> The factory default setting is the default zone for the network. If no default zone exists, the zone marked with an * is the factory default setting.

## USB menu

Menu item	Description
<b>PCL SmartSwitch</b> On Off	Sets the printer to automatically switch to PCL emulation when a print job received through a USB port requires it, regardless of the default printer language <b>Notes:</b> <ul style="list-style-type: none"> <li>• On is the factory default setting.</li> <li>• When the Off setting is used, the printer does not examine incoming data.</li> <li>• When the Off setting is used, the printer uses PostScript emulation if the PS Smartswitch setting is On. It uses the default printer language specified in the Setup menu if the PS SmartSwitch setting is Off.</li> </ul>
<b>PS SmartSwitch</b> On Off	Sets the printer to automatically switch to PS emulation when a print job received through a USB port requires it, regardless of the default printer language <b>Notes:</b> <ul style="list-style-type: none"> <li>• On is the factory default setting.</li> <li>• When the Off setting is used, the printer does not examine incoming data.</li> <li>• When the Off setting is used, the printer uses PCL emulation if the PCL Smartswitch setting is On. It uses the default printer language specified in the Setup menu if the PCL SmartSwitch setting is Off.</li> </ul>
<b>NPA Mode</b> On Off Auto	Sets the printer to perform the special processing required for bidirectional communication following the conventions defined by the NPA protocol <b>Notes:</b> <ul style="list-style-type: none"> <li>• Auto is the factory default setting.</li> <li>• Changing this setting causes the printer to restart.</li> </ul>

Menu item	Description
<b>USB Buffer</b> Disabled Auto 3K to <maximum size allowed>	Sets the size of the USB input buffer  <b>Notes:</b> <ul style="list-style-type: none"> <li>• Auto is the factory default setting.</li> <li>• The Disabled setting turns off job buffering. Any jobs already buffered are printed before normal processing is resumed.</li> <li>• The USB buffer size value can be changed in 1K increments.</li> <li>• The maximum size allowed depends on the amount of memory in the printer, the size of the other link buffers, and whether the Resource Save setting is On or Off.</li> <li>• To increase the maximum size range for the USB Buffer, disable or reduce the size of the parallel and network buffers.</li> <li>• Changing this setting causes the printer to restart.</li> </ul>
<b>Mac Binary PS</b> On Off Auto	Sets the printer to process Macintosh binary PostScript print jobs  <b>Notes:</b> <ul style="list-style-type: none"> <li>• Auto is the factory default setting.</li> <li>• The Off setting filters print jobs using the standard protocol.</li> <li>• The On setting processes raw binary PostScript print jobs.</li> </ul>
<b>USB with ENA</b> ENA Address ENA Netmask ENA Gateway	Sets the network address, netmask, and gateway information for an external print server that is attached to the printer using a USB cable  <b>Note:</b> This menu item and its submenus are available only if the printer is attached to an external print server through the USB port.

## Parallel menu

Menu item	Description
<b>PCL SmartSwitch</b> On Off	Sets the printer to automatically switch to PCL emulation when a print job received through a USB port requires it, regardless of the default printer language  <b>Notes:</b> <ul style="list-style-type: none"> <li>• On is the factory default setting.</li> <li>• When the Off setting is used, the printer does not examine incoming data.</li> <li>• When the Off setting is used, the printer uses PostScript emulation if PS SmartSwitch is set to On. It uses the default printer language specified in the Setup menu if PS SmartSwitch is set to Off.</li> </ul>
<b>PS SmartSwitch</b> On Off	Sets the printer to automatically switch to PS emulation when a print job received through a USB port requires it, regardless of the default printer language  <b>Notes:</b> <ul style="list-style-type: none"> <li>• On is the factory default setting.</li> <li>• When the Off setting is used, the printer does not examine incoming data.</li> <li>• When the Off setting is used, the printer uses PCL emulation if PCL SmartSwitch is set to On. It uses the default printer language specified in the Setup menu if PCL SmartSwitch is set to Off.</li> </ul>

Menu item	Description
<b>NPA Mode</b> Off Auto	Sets the printer to perform the special processing required for bidirectional communication following the conventions defined by the NPA protocol  <b>Notes:</b> <ul style="list-style-type: none"> <li>• Auto is the factory default setting.</li> <li>• Changing this setting automatically resets the printer.</li> </ul>
<b>Parallel Buffer</b> Disabled Auto 3K to <max size allowed>	Sets the size of the parallel input buffer  <b>Notes:</b> <ul style="list-style-type: none"> <li>• Auto is the factory default setting.</li> <li>• The Disabled setting turns off job buffering. Any jobs already buffered on the disk are printed before normal processing is resumed.</li> <li>• The parallel buffer size setting can be changed in 1-K increments.</li> <li>• The maximum size allowed depends on the amount of memory in the printer, the size of the other link buffers, and whether Resource Save is set to On or Off.</li> <li>• To increase the maximum size range for the Parallel Buffer, disable or reduce the size of the USB and network buffers.</li> <li>• Changing this setting automatically resets the printer.</li> </ul>
<b>Advanced Status</b> Off On	Enables bidirectional communication through the parallel port  <b>Notes:</b> <ul style="list-style-type: none"> <li>• On is the factory default setting.</li> <li>• The Off setting disables parallel port negotiation.</li> </ul>
<b>Protocol</b> Standard Fastbytes	Specifies the parallel port protocol  <b>Notes:</b> <ul style="list-style-type: none"> <li>• Fastbytes is the factory default setting. It provides compatibility with most existing parallel ports and is the recommended setting.</li> <li>• The Standard setting tries to resolve parallel port communication problems.</li> </ul>
<b>Honor Init</b> On Off	Determines whether the printer honors printer hardware initialization requests from the computer  <b>Notes:</b> <ul style="list-style-type: none"> <li>• Off is the factory default setting.</li> <li>• The computer requests initialization by activating the Init signal from the parallel port. Many personal computers activate the Init signal each time the computer is turned on.</li> </ul>
<b>Parallel Mode 2</b> On Off	Determines whether the parallel port data is sampled on the leading or trailing edge of strobe  <b>Note:</b> On is the factory default setting.

Menu item	Description
<b>Mac Binary PS</b> On Off Auto	Sets the printer to process Macintosh binary PostScript print jobs  <b>Notes:</b> <ul style="list-style-type: none"> <li>• Auto is the factory default setting.</li> <li>• The Off setting filters print jobs using the standard protocol.</li> <li>• The On setting processes raw binary PostScript print jobs.</li> </ul>
<b>Parallel with ENA</b> ENA Address ENA Netmask ENA Gateway	Sets the network address, netmask, and gateway information for an external print server that is attached to the printer using a parallel cable.  <b>Note:</b> This menu is available only if the printer is attached to an external print server through the parallel port.

# Understanding printer messages

## Checking the virtual display

When the Embedded Web Server is open, a virtual display appears in the top left corner of the screen. It works as an actual display would work on a printer control panel, showing printer messages.

To access the Embedded Web Server, type the printer IP address into the address field of your Web browser.

**Note:** If you do not know the IP address of the printer, then print a network setup page and locate the IP address in the TCP/IP section.

The virtual display appears in the top left corner of the screen.

## List of status and error messages

### Busy

Wait for the message to clear.

### Canceling

Wait for the message to clear.

### Close front door

Close the front door of the printer.

### Flushing buffer

Wait for the message to clear.

### Hex Trace

The printer is in Hex Trace mode.

### Invalid Engine Code

You need to download valid engine code for the printer.

**Note:** Engine code may be downloaded while this message appears on the display.

### Invalid Network Code

You need to download valid network printing code for the internal print server. The internal print server is a hardware option installed inside the printer.

**Note:** Network code may be downloaded while this message appears on the display.

## Load manual feeder with <x>

Try one or more of the following:



- Load the specified paper in the manual feeder.
- Cancel the current job.

## Load <src> with <x>

Try one or more of the following:

- Load the tray or other source with the correct paper type and size.
- Cancel the current job.

## Not Ready

Press and release either  or 

to return to the Ready state.

## Power Saver

The printer is saving power while it waits for the next print job. Send a job to print to take the printer out of Power Saver mode.

## Programming Engine Code DO NOT POWER OFF

Wait for the message to clear.

**Warning—Potential Damage:** Do not turn the printer power off while **Programming Engine Code** appears on the display.

## Programming System Code DO NOT POWER OFF

Wait for the message to clear.

**Warning—Potential Damage:** Do not turn the printer power off while **Programming System Code** appears on the display.

## Ready

The printer is ready to receive print jobs.

## Restoring Factory Defaults

Wait for the message to clear. When factory default settings are restored, all downloaded resources in the printer memory are deleted. This includes fonts, macros, and symbol sets.

## Remove paper from standard output bin

Remove the stack of paper from the standard exit bin.

## Waiting

The printer has received a job to print, but is waiting for additional data.

Try one or more of the following:

- Press  to print the contents of the buffer.
- Cancel the current print job.

## 31.yy Replace defective or missing cartridge

The toner cartridge is either missing or not functioning properly.

Try one or more of the following:

- Remove the toner cartridge, and then reinstall it.
- Remove the toner cartridge, and then install a new one.

## 32.yy Cartridge part number unsupported by device

Remove the toner cartridge, and then install a supported one.

## 34 Short paper

Try one or more of the following:

- Load the appropriate paper in the tray.
- Press  to clear the message and print the job using a different paper tray.
- Check tray length and width guides and make sure the paper is properly loaded in the tray.
- Check the Print Properties or Print Dialog settings to make sure the print job is requesting the correct paper size and type.
- Check that the paper size is correctly set. For example, if the Manual Feeder Size is set to Universal, make sure the paper is large enough for the data being printed.
- Cancel the current print job.

## 37 Insufficient memory to collate job

There is not enough memory to collate the print job. Try one or more of the following:

- To print the portion of the job already stored and begin collating the rest of the print job, press .
- Cancel the current print job.

## 38 Memory full

Try one or more of the following:

- Press  to clear the message and continue printing. The job may not print correctly.
- Cancel the current print job.
- Install additional printer memory.

## 39 Complex page, some data may not have printed

Try one or more of the following:

- Press  to clear the message and continue printing.
- Cancel the current print job.
- Install additional printer memory.

## 54 Standard network software error

Try one or more of the following:

- Press  to continue printing.
- Turn the printer off and then back on to reset the printer.
- Upgrade (flash) the network firmware in the printer or print server.

## 84 PC Kit life warning

The photoconductor kit is near exhaustion.

Try one or more of the following:

- Replace the photoconductor kit.
- Press  to clear the message and continue printing.

## 84 Replace PC Kit

The photoconductor kit is exhausted. Install a new photoconductor kit.

## 42.xy Cartridge region mismatch

Replace the toner cartridge with one that is correct for the region where you purchased your printer.

## 200.yy Paper jam

The message indicates either where the paper is jammed or the number of pages jammed.

**1** To access the jam, try one or more of the following:

- Remove Tray 1.
- Open the front door, and then remove the photoconductor kit and toner cartridge unit.

**2** Remove the jam.

**3** Replace the photoconductor kit and toner cartridge unit if you have removed it.

**4** Close any open doors or trays.

**5** Press  to continue printing.



## 201.yy Paper jam

The message indicates either where the paper is jammed or the number of pages jammed.

- 1 Open the front door, and then remove the photoconductor kit and toner cartridge unit.
- 2 Remove the jam.
- 3 Replace the photoconductor kit and toner cartridge unit.
- 4 Close the front door.
- 5 Press  to continue printing.

## 202.yy Paper jam

The message indicates either where the paper is jammed or the number of pages jammed.

- 1 Open the front door.
- 2 Open the rear door.
- 3 Remove the jam.
- 4 Close both doors.
- 5 Press  to continue printing.

## 231.yy Paper jam

**Note:** This message appears only if the printer has a duplex unit.

The message indicates either where the paper is jammed or the number of pages jammed.

- 1 Open the front door.
- 2 Open the rear door.
- 3 Remove the jam.
- 4 Close both doors.
- 5 Press  to continue printing.

## 233.yy Paper jam

**Note:** This message appears only if the printer has a duplex unit.

The message indicates either where the paper is jammed or the number of pages jammed.

- 1 To access the jam, try one or more of the following:
  - Remove Tray 1, and then depress the lever.
  - Open the front door, and then open the rear door.
- 2 Remove the jam.
- 3 Close any open doors or trays.
- 4 Press  to continue printing.

## 234.yy Paper jam

**Note:** This message appears only if the printer has a duplex unit.

The message indicates either where the paper is jammed or the number of pages jammed.

- 1 To access the jam, try one or more of the following:
  - Open the front door, and then open the rear door.
  - Remove Tray 1, and then depress the lever.
- 2 Remove the jam.
- 3 Close any open doors or trays.
- 4 Press  to continue printing.

## 235.yy Paper jam

**Note:** This message appears only if the printer has a duplex unit.

The message indicates either where the paper is jammed or the number of pages jammed.

- 1 Remove the jam from the standard exit bin.
- 2 Check the paper size to ensure that it is supported by the printer.
- 3 Press  to continue printing.

## 24x.yy Paper jam

The message indicates either where the paper is jammed, or the number of pages jammed.

- 1 To access the jam, try one or more of the following:
  - Remove Tray 1.
  - Open the front door, and then remove the photoconductor kit and toner cartridge unit.
  - Remove Tray 2.
- 2 Remove the jam.
- 3 Replace the photoconductor kit and toner cartridge unit if you have removed it.
- 4 Close any open doors or trays.
- 5 Press  to continue printing.

## 251.yy Paper jam

The message indicates either where the paper is jammed or how many pages are jammed.

- 1 Remove the jam from the manual feeder.
- 2 Press  to continue printing.

# Maintaining the printer

Periodically, certain tasks are required to maintain optimum print quality.

## Cleaning the exterior of the printer

- 1 Make sure that the printer is turned off and unplugged from the wall outlet.



**CAUTION—SHOCK HAZARD:** To avoid the risk of electric shock when cleaning the exterior of the printer, unplug the power cord from the wall outlet and disconnect all cables to the printer before proceeding.

- 2 Remove all paper from the printer.
- 3 Dampen a clean, lint-free cloth with water.

**Warning—Potential Damage:** Do not use household cleaners or detergents, as they may damage the finish of the printer.

- 4 Wipe only the outside of the printer.

**Warning—Potential Damage:** Using a damp cloth to clean the interior may cause damage to your printer.

- 5 Make sure all areas of the printer are dry before beginning a new print job.

## Storing supplies

Choose a cool, clean storage area for the printer supplies. Store supplies right side up in their original packing until you are ready to use them.

Do not expose supplies to:

- Direct sunlight
- Temperatures above 35°C (95°F)
- High humidity above 80%
- Salty air
- Corrosive gases
- Heavy dust

## Conserving supplies

### Conserving supplies using the printer menus

There are some settings you can change in the printer menus that will help you conserve toner and paper.

To access printer menus:

- Open the Embedded Web Server by typing the printer IP address into the address field of your Web browser.  
**Note:** If you do not know the IP address of the printer, print a network setup page and locate the IP address in the TCP/IP section.
- If the printer is connected to the computer by a USB or parallel cable, open the Local Printer Settings Utility for Windows or Printer Settings for Macintosh. One of these utilities installs with the printer software.

Supply	Path to menu item	Purpose of menu item
Toner	From the Quality menu, you can adjust the Toner Darkness setting.	Lets you adjust the level of toner released on a sheet of paper or specialty media. The values range from 1 (lightest setting) to 10 (darkest setting) with 8 being the factory default setting.
Paper or specialty media	From the Finishing menu, you can adjust the N-up (Multipage Print) setting.	Lets you select to print two or more page images on one side of a sheet. Values for N-up are 2-Up, 3-Up, 4-Up, 6-Up, 9-Up, 12-Up, and 16-Up.
	From the Finishing menu, you can select Duplex.	Lets you print on both sides of a sheet of paper

## Conserving supplies when printing multiple copies

If you need to print several copies, you can conserve supplies by printing the first copy and checking it for accuracy before printing the remaining copies.

## Checking the status of supplies

A message appears on the display when a replacement supply item is needed or when maintenance is required.

### Checking the status of supplies from a network computer

**Note:** The computer must be connected to the same network as the printer.

- 1 Type the printer IP address into the address field of your Web browser.

**Note:** If you do not know the IP address of the printer, print a network setup page and locate the IP address in the TCP/IP section.

- 2 Click **Device Status**. The Device Status page appears, displaying a summary of supply levels.

# Ordering supplies

To order supplies in the U.S., contact Lexmark at 1-800-539-6275 for information about Lexmark authorized supplies dealers in your area. In other countries or regions, visit the Lexmark Web Site at [www.lexmark.com](http://www.lexmark.com) or contact the place where you purchased the printer.

**Note:** All life estimates for printer supplies assume printing on letter- or A4-size plain paper.

## Ordering toner cartridges

When **88 Toner is low** appears or when the print becomes faded, you may be able to extend the life of the toner cartridge:

- 1 Remove the toner cartridge.
- 2 Firmly shake the cartridge side-to-side and front-to-back several times to redistribute toner.

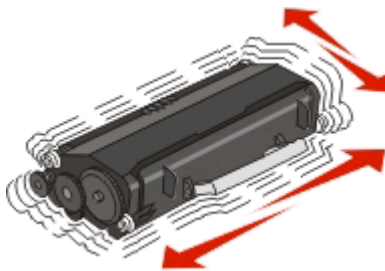

- 3 Reinsert the cartridge and continue printing.

**Note:** Repeat this procedure multiple times until the print remains faded, and then replace the cartridge.

**The recommended toner cartridges specifically designed for your printer are as follows. The part numbers are indicated.**

Part name	Regular cartridge	Lexmark Return Program Cartridge
<b>For the US and Canada</b>		
Toner cartridge	E260A21A	E260A11A
<b>For Europe, the Middle East, and Africa</b>		
Toner cartridge	E260A21E	E260A11E
<b>For the Asia Pacific Region, including Australia, New Zealand, and India</b>		
Toner cartridge	E260A21P	E260A11P
<b>For Latin America</b>		
Toner cartridge	E260A21L	E260A11L

# Ordering a photoconductor kit

Depending on your printer model, the printer issues a message or a light sequence to let you know the photoconductor kit is near its end of life. At this time, order a photoconductor kit. You can also see the status of the photoconductor kit by printing a network setup page.

Part name	Part number
Photoconductor kit	E260X22G

# Replacing supplies

## Replacing the toner cartridge

### Light sequence

Toner is low

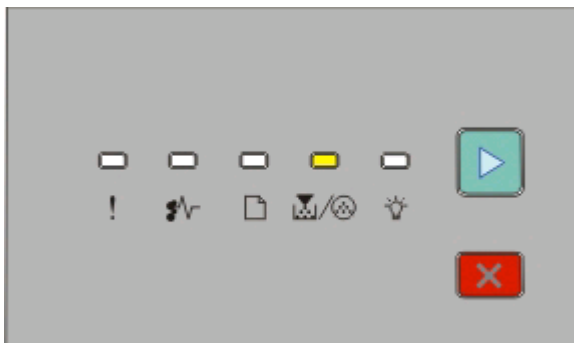

- - On
- - On

When the “Toner is low” light sequence appears, or when you experience faded print, remove the toner cartridge. Firmly shake it side-to-side and front-to-back several times to redistribute the toner, and then reinsert it and continue printing. When shaking the cartridge no longer improves the print quality, replace the toner cartridge.

**Note:** You can check to see approximately how much toner is left in your cartridge by printing a menu settings page.

To replace the toner cartridge:

- 1 Open the front door by pressing the button on the left side of the printer and lowering the door.

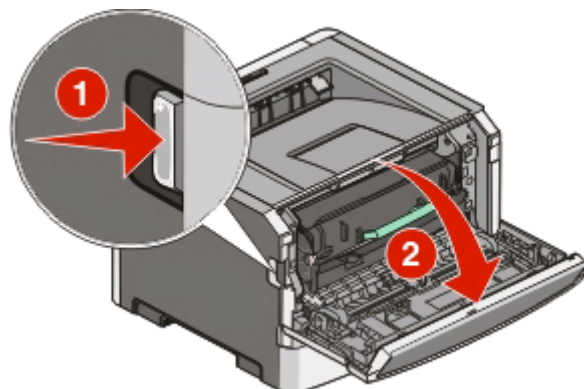

- 2 Press the button on the base of the photoconductor kit, and then pull the toner cartridge out using the handle.

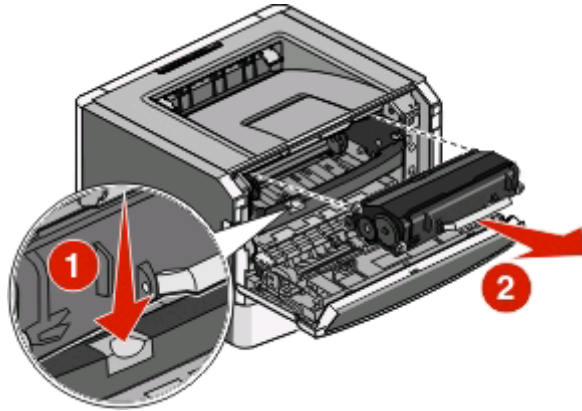

- 3 Unpack the new toner cartridge.

**Warning—Potential Damage:** When replacing a toner cartridge, do not leave the new cartridge exposed to direct light for an extended period of time. Extended light exposure can cause print quality problems.

- 4 Rotate the cartridge in all directions to distribute the toner.

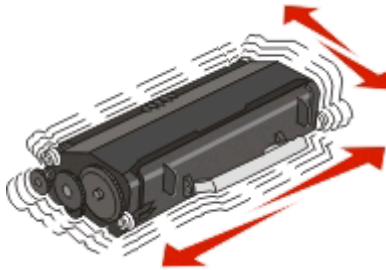

- 5 Install the new toner cartridge by aligning the rollers on the toner cartridge with the arrows on the tracks of the photoconductor kit. Push the toner cartridge in as far as it will go. The cartridge *clicks* into place when correctly installed.

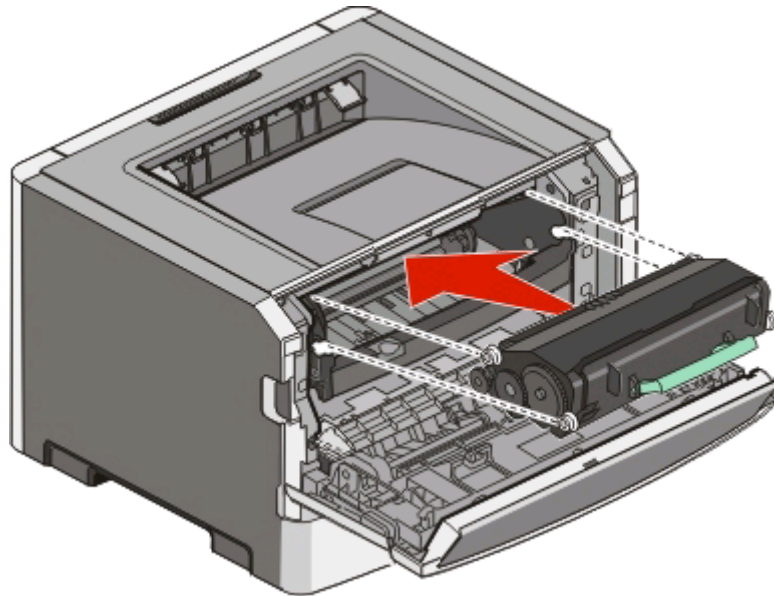

- 6 Close the front door.

# Replacing the photoconductor kit

The printer notifies you when the photoconductor kit reaches a page maximum. The printer does this by displaying the “Photoconductor life warning” light sequence or the “Replace photoconductor” light sequence.

## Light sequences

### Photoconductor life warning

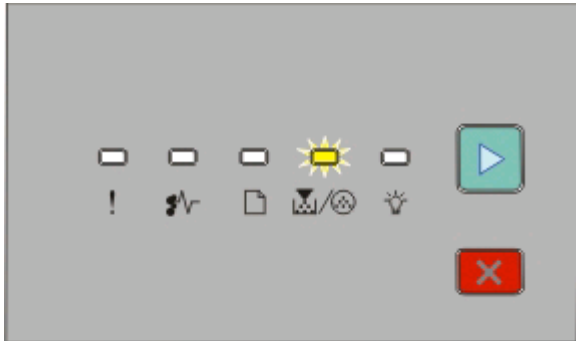

! - Blinking

▶ - On

### Replace photoconductor

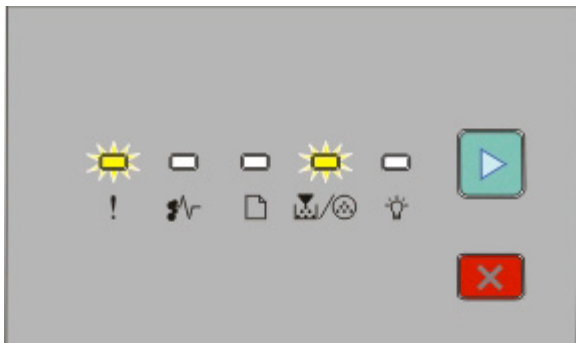

! - Blinking

! - Blinking

▶ - On

When you first receive either light sequence, you should immediately order a new photoconductor kit. While the printer may continue to function properly after the photoconductor kit has reached its official end-of-life, print quality significantly decreases.

**Note:** The photoconductor kit is one item only.

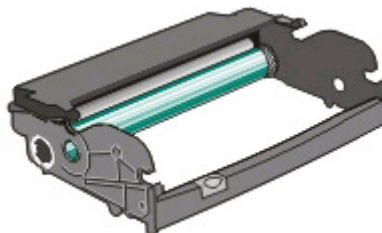



To replace the photoconductor kit:

- 1 Open the front door by pressing the button on the left side of the printer and lowering the front door.
- 2 Pull the photoconductor kit and toner cartridge together as a unit out of the printer by pulling on the toner cartridge handle.

**Note:** The photoconductor kit and toner cartridge form a unit.

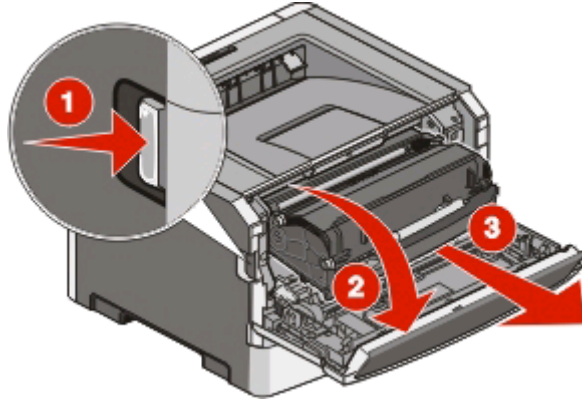

Place the unit on a flat, clean surface.

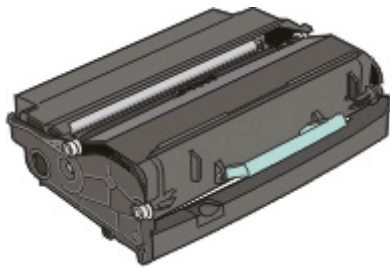

- 3 Press the button on the base of the photoconductor kit. Pull the toner cartridge up and out using the handle.

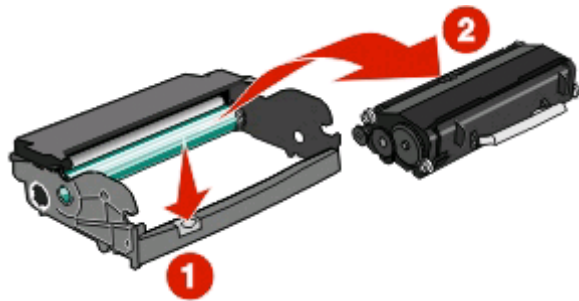

- 4 Unpack the new photoconductor kit.

**Warning—Potential Damage:** Be careful not to touch the photoconductor drum. Doing so may affect the print quality of future print jobs.

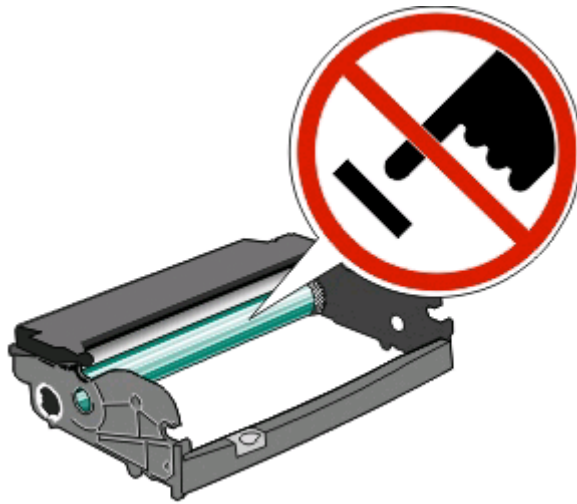

- 5 Insert the toner cartridge into the photoconductor kit by aligning the rollers on the toner cartridge with the tracks. Push the toner cartridge in until it *clicks* into place.

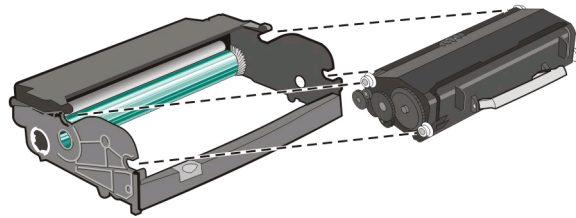

- 6 Install the unit into the printer by aligning the arrows on the guides of the unit with the arrows in the printer. Push the unit as far as it will go.

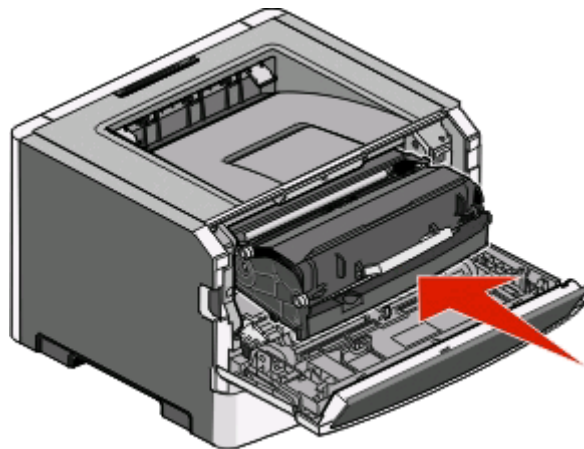

- 7 After you replace the photoconductor kit, reset the photoconductor counter. To reset the counter, see the instruction sheet that came with the new photoconductor kit.

**Warning—Potential Damage:** Resetting the photoconductor counter without replacing the photoconductor kit may damage your printer and void your warranty.

- 8 Close the front door.

# Recycling Lexmark products

To return Lexmark products to Lexmark for recycling:

- 1 Visit our Web site at [www.lexmark.com/recycle](http://www.lexmark.com/recycle).
- 2 Find the product type you want to recycle, and then select your country from the list.
- 3 Follow the instructions on the computer screen.

## Moving the printer

### Before moving the printer



**CAUTION—POTENTIAL INJURY:** Follow these guidelines to avoid personal injury or printer damage:

- Turn the printer off using the power switch, and then unplug the power cord from the wall outlet.
- Disconnect all cords and cables from the printer before moving it.
- Lift the printer off of the optional drawer and set it aside instead of trying to lift the drawer and printer at the same time.

**Note:** Use the handholds located on both sides of the printer to lift it off the optional drawer.

- Make sure your fingers are not under the printer when you set it down.

**Warning—Potential Damage:** Damage to the printer caused by improper moving is not covered by the printer warranty.

### Moving the printer to another location

The printer and options can be safely moved to another location by following these precautions:

- Any cart used to move the printer must have a surface able to support the full footprint of the printer. Any cart used to move the options must have a surface able to support the dimensions of the options.
- Keep the printer in an upright position.
- Avoid severe jarring movements.

### Shipping the printer

When shipping the printer, use the original packaging or call the place of purchase for a relocation kit.

# Administrative support

## Adjusting Power Saver

To increase or decrease the number of minutes before the printer enters Power Saver mode, do one of the following:

- If your printer is on a network, access the Embedded Web Server:
  - 1 Type the printer IP address into the address field of your Web browser.

**Note:** If you do not know the IP address of the printer, print a network setup page and locate the IP address in the TCP/IP section.
  - 2 Click **Settings**, and then click **General Settings**.
  - 3 Click **Timeouts**, and then, in the Power Saver box, increase or decrease the number of minutes you want the printer to wait before it enters Power Saver mode. Available settings range from 1–240 minutes.
  - 4 Click **Submit**.
- If your printer is connected to a computer by a USB or parallel cable, use the Local Printer Settings Utility for Windows or Printer Settings for Macintosh.
  - 1 Click **Setup**.
  - 2 Make sure the Power Saver check box is selected.
  - 3 Clicking the small arrow buttons, increase or decrease the number of minutes before the printer enters Power Saver mode. Available settings range from 1–240 minutes.
  - 4 From the menu bar, click **Actions** → **Apply Settings**.

## Restoring the factory default settings

Do one of the following:

- If your printer is on a network, access the Embedded Web Server:
  - 1 Type the printer IP address into the address field of your Web browser.

**Note:** If you do not know the IP address of the printer, print a network setup page and locate the IP address in the TCP/IP section.
  - 2 From the Settings screen, click **General Settings**.
  - 3 Under Factory Defaults, select **Restore Now**, and then click **Submit**.
- If your printer is connected to a computer by a USB or parallel cable, use the Local Printer Settings Utility for Windows or Printer Settings for Macintosh.
  - 1 Open the utility.
  - 2 Do one of the following:
    - From the Local Printer Settings Utility menu bar, click **Actions** → **Restore Factory Defaults**.
    - From Printer Settings, click **Factory Defaults**.

**Warning—Potential Damage:** Restore Factory Defaults returns all printer settings to the factory default settings except Network/Port menu settings. All downloads stored in RAM are deleted. Downloads stored in flash memory or on a printer hard disk are not affected.

- You can also restore factory default settings using the printer control panel. For instructions, print a printer settings configuration sheet.

## Checking the device status

From the Device Status page of the Embedded Web Server, it is possible to see tray settings, the level of toner in the toner cartridge, the percentage of life remaining in the photoconductor kit, and capacity measurements of certain printer parts. To access the device status:

- 1 Type the printer IP address in the address field of your Web browser.

**Note:** If you do not know the IP address of the printer, print a network setup page and locate the IP address in the TCP/IP section.

- 2 Click the **Device Status** tab. The following menu appears:

### Device Status

Toner Status

Paper Input Tray

Paper Output Bin

Device Type

Speed

Toner Cartridge Capacity

PC Unit Life Remaining

## Viewing reports

You can view some reports from the Embedded Web Server. These reports are useful for assessing the status of the printer, the network, and supplies. To view reports from a network printer:

- 1 Type the printer IP address into the address field of your Web browser.

**Note:** If you do not know the IP address of the printer, then print a network setup page and locate the IP address in the TCP/IP section.

- 2 Click **Reports**.

The following reports may be viewed from the Embedded Web Server:

### Reports

Device Statistics

Device Settings

Device Information

Profiles List

Printer Server Setup Page

The reports have the following subcategories:

<b>Device Statistics</b>	<b>Device Settings</b>	<b>Device Information</b>	<b>Printer Server Setup Page</b>
Job Information	Paper Menu	Page Count	Ethernet10/100
Jobs by Document Length	Reports	Installed Memory	Standard Network Card
Other Job Data	Settings	Processor Speed	Integrated Network Option Settings
Media Sheet Count	Network/Ports	Serial Number	TCP/IP
	Reports	Engine ID	IPv6
	Network Card	Loader	
	TCP/IP	Kernel	
	IPv6	Base	
	USB Menu	Network	
	Warnings	Network Driver	
	Device Information	Engine	
	Cartridge Information	Font	

## Restricting access to printer menus

You can safeguard entry to menus by creating passwords and choosing specific menus to protect. Each time a protected menu is selected, the user will be prompted to enter the correct password.

To protect printer menus using the Embedded Web Server:

- 1 Type the printer IP address into the address field of your Web browser.

**Note:** If you do not know the IP address of the printer, then print a network setup page and locate the IP address in the TCP/IP section.

- 2 Click **Settings**.

- 3 Under Other Settings, click **Security**.

- 4 Click **Web Page Password Protect**. It is possible to protect entry to the Paper, Reports, Settings, and Network/Ports menus.

- 5 From this screen, you may set a User Password and an Advanced Password. Determine which password will access each menu. You may also choose not to protect a menu.

**Note:** The Security menu is always password-protected when either an Advanced Password or a User Password has been set. If both passwords have been set, then only the Advanced Password is valid for access to the Security menu mode.

- 6 Click **Submit** to save your settings.

## Setting up e-mail alerts

You can have the printer send you an e-mail when the supplies are getting low or when the paper needs to be changed, added, or unjammed.

To set up e-mail alerts:

- 1 Type the printer IP address into the address field of your Web browser.  
**Note:** If you do not know the IP address of the printer, then print a network setup page and locate the IP address in the TCP/IP section.
- 2 Click **Settings**.
- 3 Under Other Settings, click **E-mail Alert Setup**.
- 4 Select the items for notification and type in the e-mail addresses that you want to receive e-mail alerts.
- 5 Click **Submit**.

**Note:** See your system support person to set up the e-mail server.

## Configuring supply notifications

You can determine how you would like to be notified when supplies run low or reach their end-of-life.

To configure supply notifications using the Embedded Web Server:

- 1 Type the printer IP address into the address field of your Web browser.  
**Note:** If you do not know the IP address of the printer, then print a network setup page and locate the IP address in the TCP/IP section.
- 2 Click **Settings**.
- 3 Click **Print Settings**.
- 4 Click **Supply Notifications**.
- 5 From the drop-down box for each supply, select among the options for notification. Explanations for each option are provided.
- 6 Click **Submit** to save your selections.

## Copying printer settings to other printers

Using the Embedded Web Server, you can copy printer settings to up to 15 other network printers. To copy printer settings:

- 1 Type the printer IP address into the address field of your Web browser.  
**Note:** If you do not know the IP address of the printer, then print a network setup page and locate the IP address in the TCP/IP section.
- 2 Click **Copy Printer Settings**.
- 3 To change the language, select a language from the drop-down list, and then click **Click here to submit language**.
- 4 Click **Printer Settings**.

**5** Enter the IP addresses of the source and target printers.

**Note:** To add additional target printers, click the **Add Target IP** button.

**6** Click **Copy Printer Settings**.



# Clearing jams

## Avoiding jams

The following hints can help you avoid jams:

- Use only recommended paper or specialty media. For more information, see “Paper and specialty media guide” on page 51.
- Do not load too much paper. Make sure the stack height does not exceed the indicated maximum height.
- Do not load wrinkled, creased, damp, or curled paper.
- Flex, fan, and straighten paper before loading it.



- Do not use paper that has been cut or trimmed by hand.
- Do not mix paper sizes, weights, or types in the same stack.
- Store the paper in an appropriate environment.
- Do not remove trays while the printer is printing. Wait for the  light to come on before removing a tray. The light sequence for loading paper also signals that the tray may be removed:



Load paper

 - On

- Do not load the manual feeder while the printer is printing. Wait for the  light to come on.
- Push all trays in firmly after loading paper.
- Make sure the guides in the trays are properly positioned, and are not pressing too tightly against the paper.
- Make sure all paper sizes and paper types are set correctly.
- Make sure all printer cables are attached correctly. For more information, see the setup documentation.

# Accessing jam areas

Open doors and remove trays to access jam areas. The following illustration shows possible jam areas:

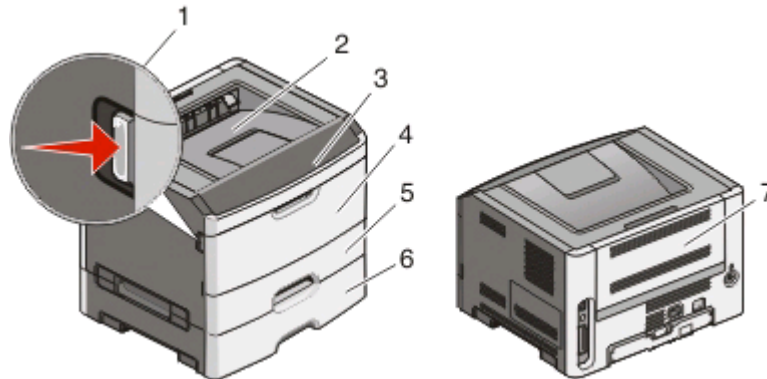

Access point	Description
1	Push button to open the front door. Inside this door is the unit housing the toner cartridge and photoconductor kit.
2	Standard exit bin
3	Front door
4	Manual feeder door
5	Standard 250-sheet tray (Tray 1)
6	Optional tray (Tray 2)
7	Rear door

# Understanding jam lights and access locations

The following table lists the jam lights and messages and provides brief instructions for how to access each jam. More detailed instructions follow.

**Note:** The jam messages listed appear on the virtual display of the Embedded Web Server.

200.yy Paper jam

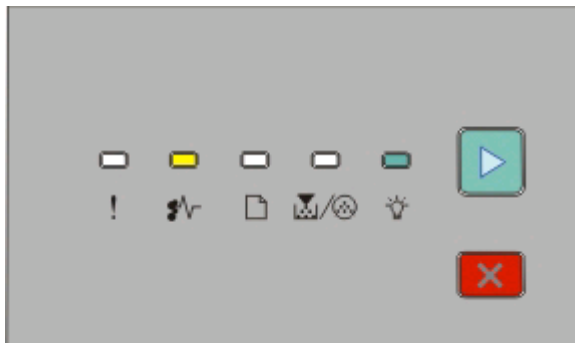

200.yy Paper jam

! - On

💡 - On

▶ - On

Try one of the following:

- Remove Tray 1.
- Open the front door, and then remove the photoconductor kit and toner cartridge unit.

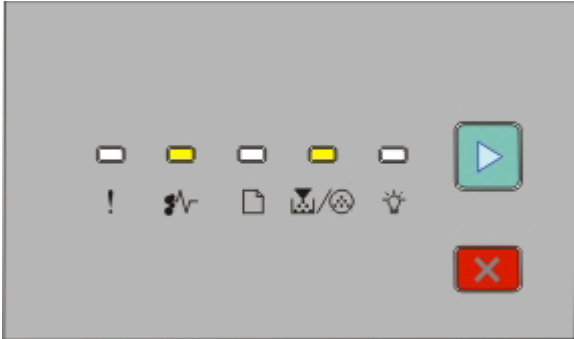

**201.yy Paper jam**

⚡ - On

📄/🚫 - On

▶ - On

Open the front door, and then remove the photoconductor kit and toner cartridge unit.

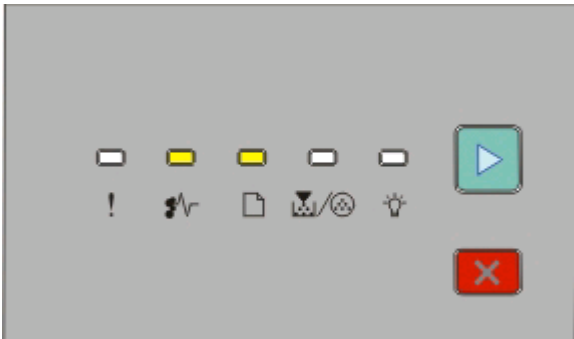

**202.yy Paper jam**

⚡ - On

📄 - On

▶ - On

Open the front door, and then open the rear door.



**231.yy Paper jam**

⚡ - On

📄 - Blinking

▶ - On

Open the front door, and then open the rear door.



**233.yy Paper jam**

⚡ - On

📄 - Blinking

📄/⊗ - Blinking

▶ - On

Try one of the following:

- Remove Tray 1, and then depress the lever.
- Open the front door, and then open the rear door.

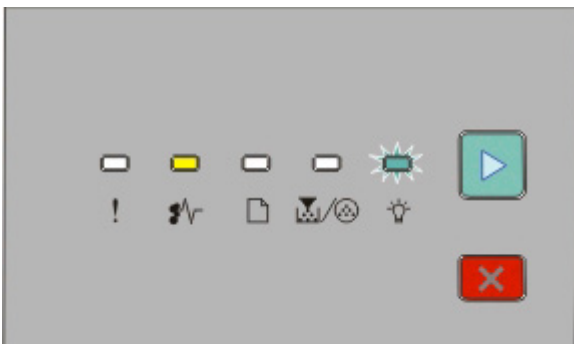

**234.yy Paper jam**

🔊 - On

💡 - Blinking

▶ - On

Try one of the following:

- Open the front door, and then open the rear door.
- Remove Tray 1, and then depress the lever.



#### 235.yy Paper jam

🔊 - On

📄 - Blinking

💡 - Blinking

▶ - On

Remove the jam from the standard exit bin.

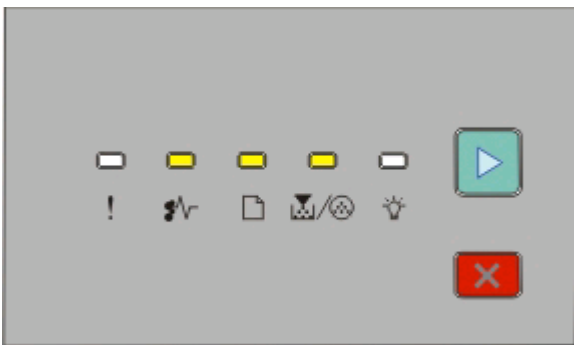

#### 24x.yy Paper jam

🔊 - On

📄 - On

🗑️ - On

▶ - On

Try one of the following:

- Remove Tray 1.
- Open the front door, and then remove the photoconductor kit and toner cartridge unit.
- Remove Tray 2.



### 251.yy Paper jam

⚡ - On

📄/🚫 - On

💡 - On

▶ - On

Remove the jam from the manual feeder.

## Clearing jams behind the photoconductor kit and toner cartridge

1 Push the release button, and then lower the front door.

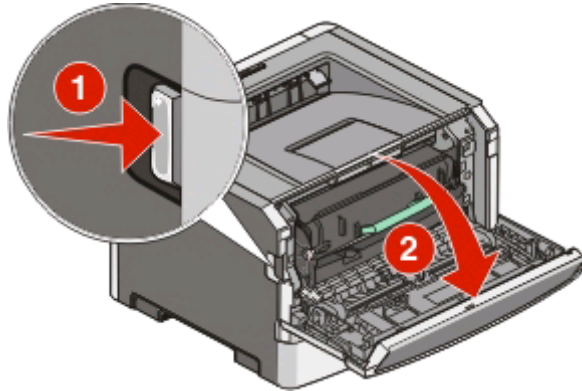

- 2 Lift and pull the unit containing the photoconductor kit and the toner cartridge out of the printer. Set the unit aside on a flat, clean surface.

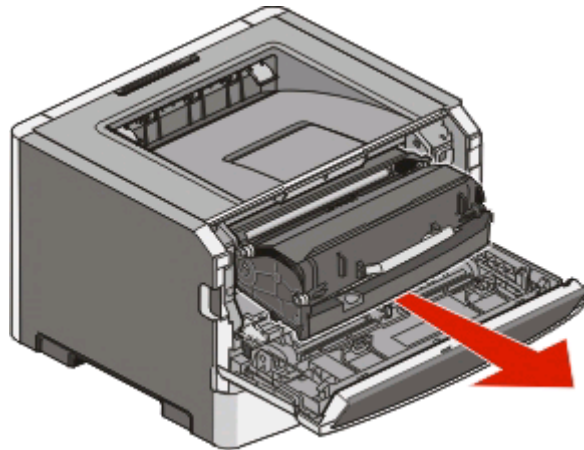

**Warning—Potential Damage:** Do not touch the photoconductor on the underside of the photoconductor kit. Use the cartridge handle whenever you are holding the cartridge.

**CAUTION—HOT SURFACE:** The fuser and the inside of the printer near the fuser may be hot. To reduce the risk of injury from a hot component, allow the surface to cool before removing paper from this area.

- 3 Remove the jammed paper.

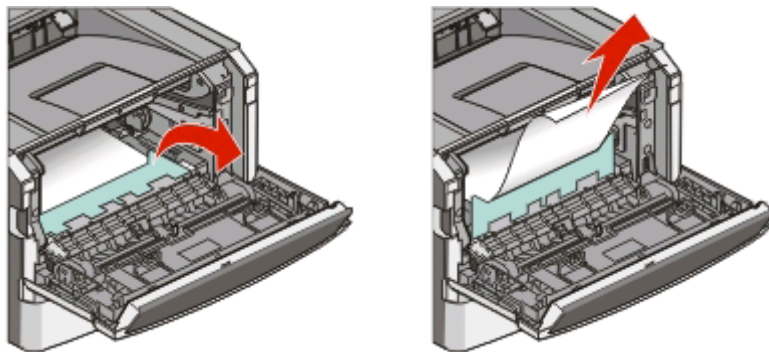

**Note:** If the paper is not easy to remove, then open the rear door to remove the paper.

- 4 Align and reinstall the unit.

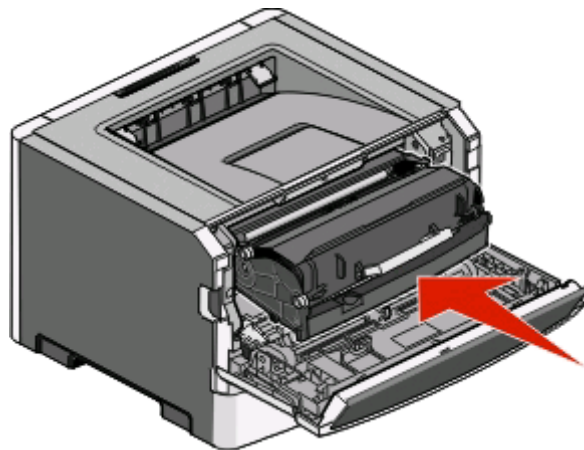

- 5 Close the front door.
- 6 Press  to continue printing.

## Clearing jams from the standard exit bin

A duplex print job was sent to the printer using a paper size not supported for duplex printing. A sheet is jammed in the standard exit bin.

To remove the jam, gently pull the sheet straight out of the standard exit bin.

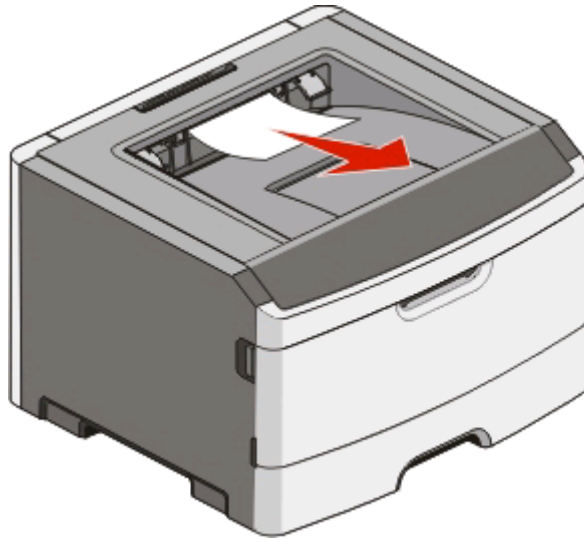

## Clearing jams from Tray 1

To see whether paper is jammed in or behind Tray 1, the standard tray:

- 1 Remove Tray 1.

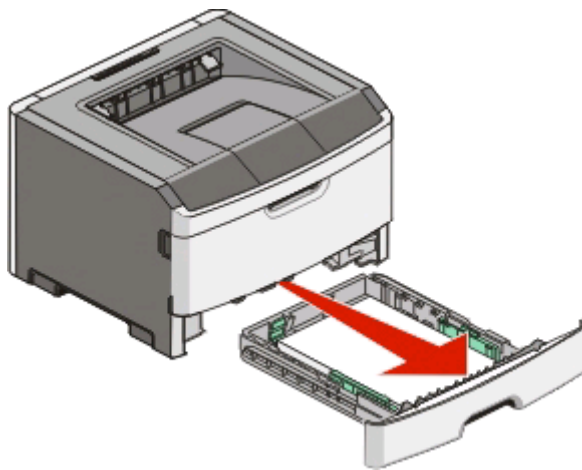



2 Remove the jammed paper.

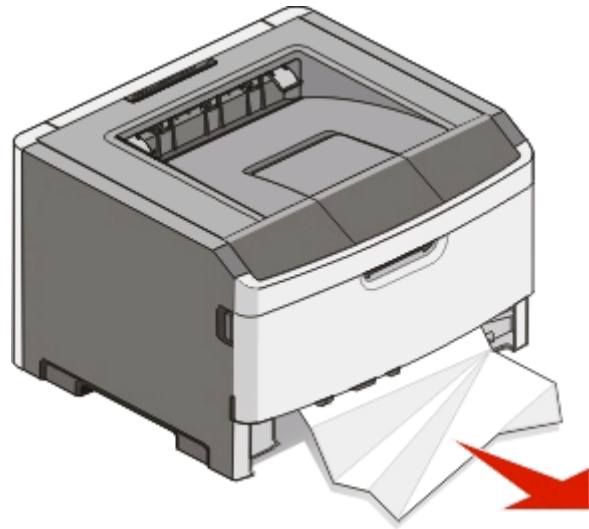

3 If necessary, depress the lever to free the paper and remove the jam.

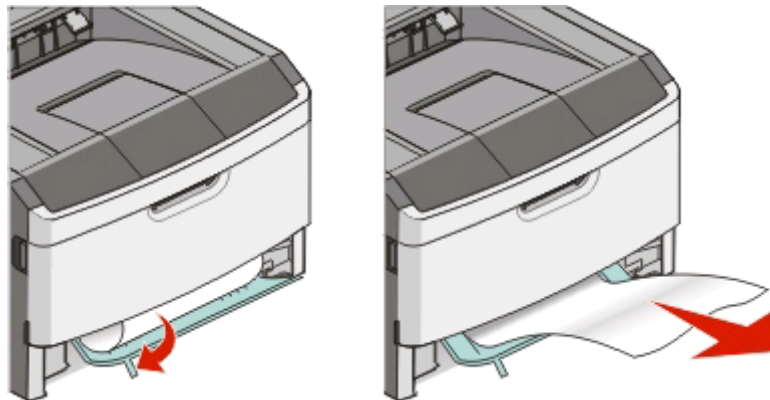

4 Insert the tray.

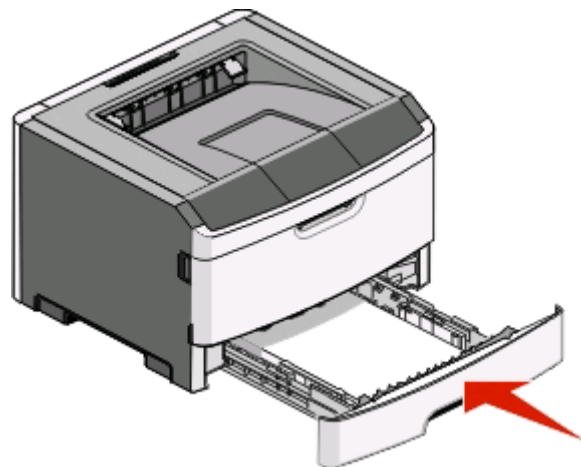

5 Press  to continue printing.

## Clearing jams from Tray 2

To see whether paper is jammed in or behind Tray 2:

- 1 Remove Tray 2.

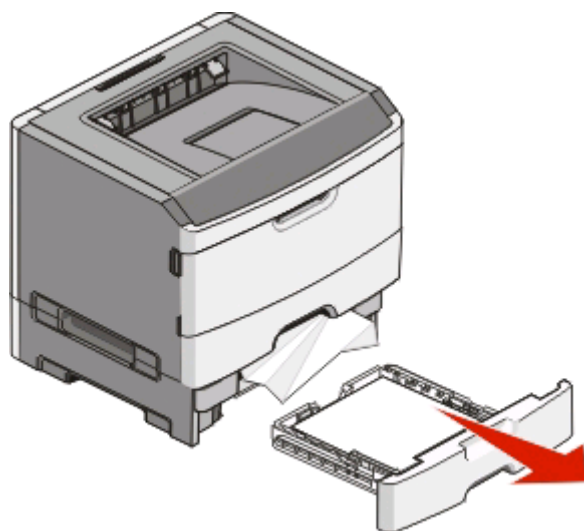

- 2 Remove the jammed paper.

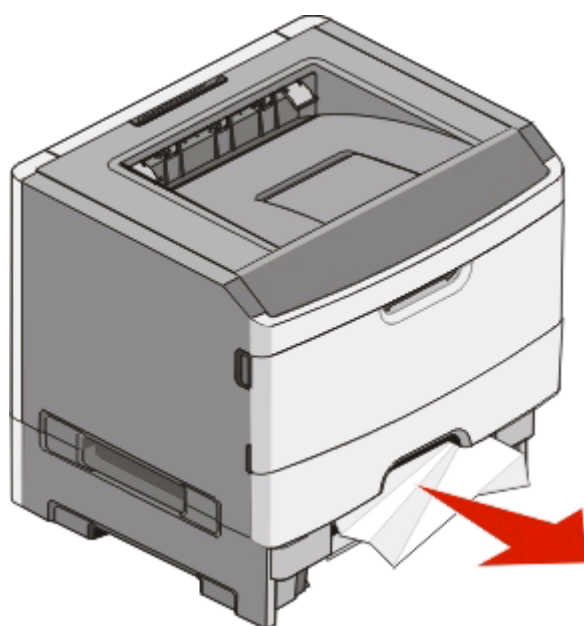

**3** Insert the tray.

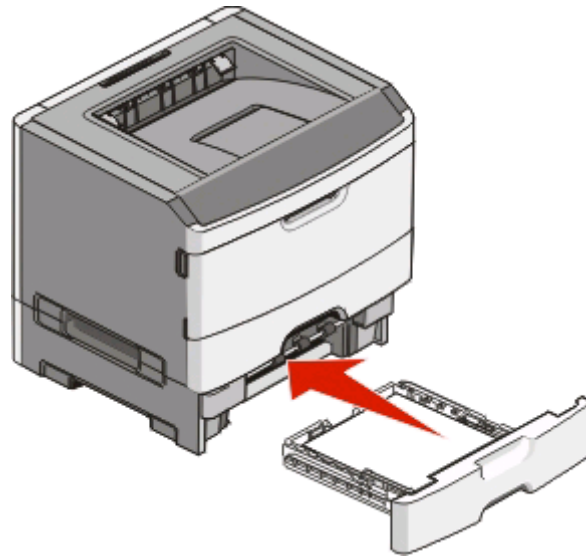

**4** Press  to continue printing.

## Clearing jams in the manual feeder

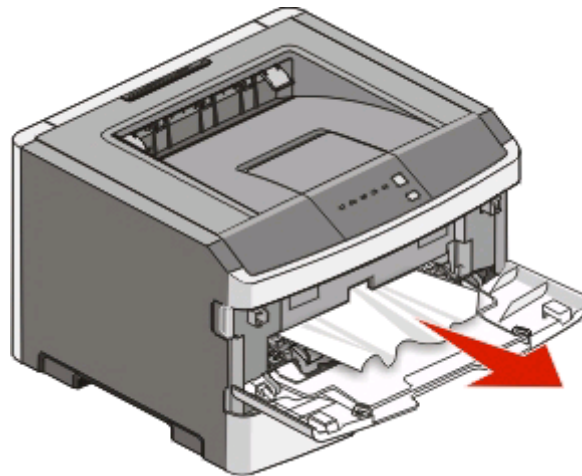

Paper jammed in the manual feeder can usually be grasped and pulled straight out. If the jam cannot be removed this way, check for jammed paper behind the photoconductor kit and toner cartridge unit. For more information, see “Clearing jams behind the photoconductor kit and toner cartridge” on page 118.

# Clearing jams behind the rear door

If the paper is exiting the printer, pull the paper out. If the paper is not exiting the printer:

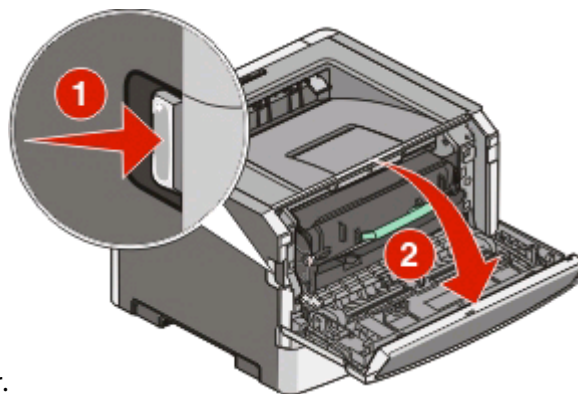

- 1 Push the release button, and then lower the front door.
- 2 Pull open the rear door.

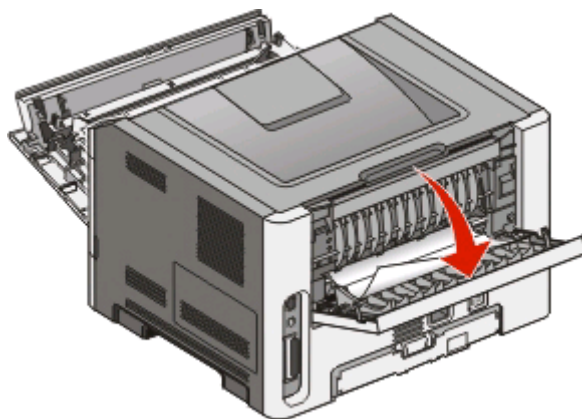

The paper may be jammed with one end caught in the exit bin.

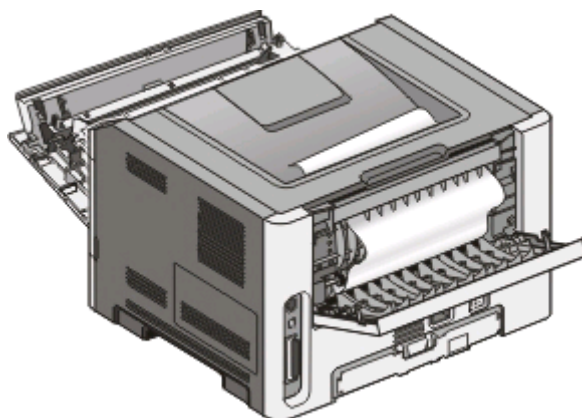

**3** Remove the jammed paper.

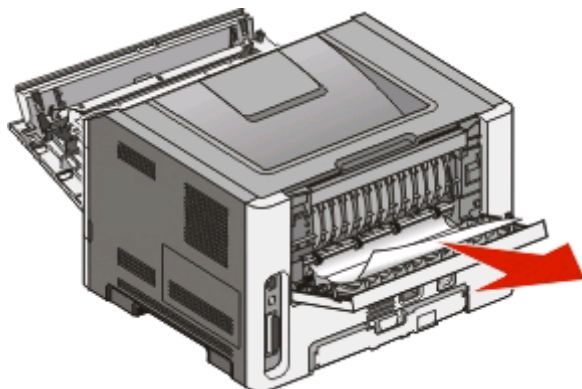

**4** Close both the front and rear doors.

**5** Press  to continue printing.

# Troubleshooting

## Solving basic printer problems

If there are basic printer problems, or the printer is unresponsive, make sure:

- The power cord is plugged into the printer and a properly grounded electrical outlet.
- The electrical outlet is not turned off by any switch or breaker.
- The *Ground Fault Circuit Interrupter* (GFCI) has not tripped.
- The printer is not plugged into any surge protectors, uninterrupted power supplies, or extension cords.
- Other electronic equipment plugged into the outlet is working.
- The printer is turned on. Check the printer power switch.
- The printer cable is securely attached to the printer and the host computer, print server, option, or other network device.
- All options are properly installed.
- The printer driver settings are correct.

Once you have checked each of these possibilities, turn the printer off, wait for about 10 seconds, and then turn the printer back on. This often fixes the problem.

## Solving printing problems

### Jobs do not print

These are possible solutions. Try one or more of the following:

#### **MAKE SURE THE PRINTER IS READY TO PRINT**

Make sure the  light is on before sending a job to print.

#### **CHECK TO SEE IF THE STANDARD EXIT BIN IS FULL**

Remove the stack of paper from the standard exit bin.

#### **CHECK TO SEE IF THE TRAY IS EMPTY**

Load paper in the tray.

#### **MAKE SURE THE CORRECT PRINTER SOFTWARE IS INSTALLED**

Verify that you installed the correct printer software for your printer model.

Click **Install printer and software** on the *Software and Documentation* CD to check which software is installed. Make sure the model number of the software matches the model number of your printer.

To verify that the printer software is the most current, check the Lexmark Web site at **[www.lexmark.com](http://www.lexmark.com)**.

## MAKE SURE THE PRINTER IS CONNECTED TO THE NETWORK

Print a network setup page and check that the status shows **Connected**. If the status is **Not Connected**, check the network cables, and then try printing the network setup page again. Contact your system support person to make sure the network is functioning correctly.

Copies of the printer software are also available on the Lexmark Web site at [www.lexmark.com](http://www.lexmark.com).

## MAKE SURE YOU ARE USING A RECOMMENDED USB, PARALLEL, OR ETHERNET CABLE

For more information, visit the Lexmark Web site at [www.lexmark.com](http://www.lexmark.com).

## MAKE SURE PRINTER CABLES ARE SECURELY CONNECTED

Check the cable connections to the printer to make sure they are secure. For more information, see the setup documentation that came with the printer.

## Multiple-language PDFs do not print

The documents contain unavailable fonts.

- 1 Open the document you want to print in Adobe Acrobat.
- 2 Click the printer icon.  
The Print dialog appears.
- 3 Select **Print as image**.
- 4 Click **OK**.

## Job takes longer than expected to print

The job is too complex.

Reduce the complexity of your print job by eliminating the number and size of fonts, the number and complexity of images, and the number of pages in the job.

## Job prints from the wrong tray or on the wrong paper

These are possible solutions. Try one or more of the following:

### CHECK THE PAPER SIZE AND PAPER TYPE SETTINGS

From the Paper menu, make sure the Paper Size and Paper Type settings match the paper loaded in the trays. To access the Paper menu, do one of the following:

- If the printer is on a network, access the Embedded Web Server by typing the IP address of the printer in the address bar of a Web browser. From the Settings tab, click **Paper Menu**
- If the printer is connected to a computer by a USB or parallel cable, open the Local Printer Settings Utility for Windows or Printer Settings for Macintosh. One of these utilities installs with the printer software.

## CHECK THE PAPER TAB SETTINGS IN YOUR OPERATING SYSTEM

Open Print Properties in a Windows operating system or the print dialog in a Macintosh operating system. Make sure the Input options settings for Paper size, Paper tray, and Paper type correspond with the paper loaded in the tray.

## Incorrect characters print

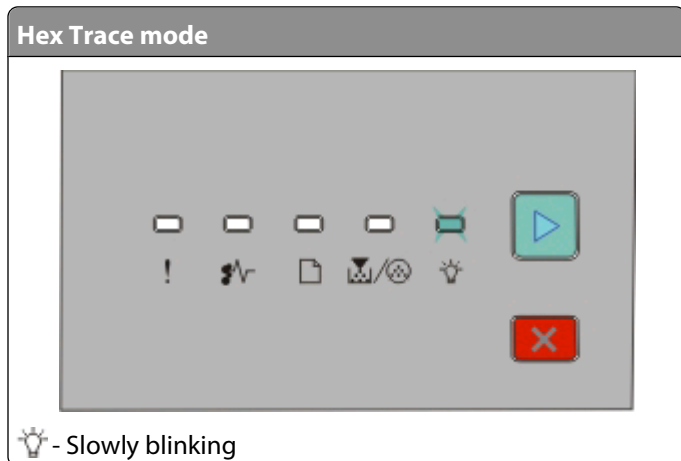

Make sure the printer is not in Hex Trace mode. If the “Hex Trace mode” light sequence appears, you must exit Hex Trace mode before you can print your job. To exit Hex Trace mode, turn the printer off and back on.

## Tray linking does not work

Make sure to do all of the following:

- Load both Tray 1 and Tray 2 with the same paper size and type.
- From Print Properties or the print dialog, change the Paper source to Automatically select.

## Large jobs do not collate

These are possible solutions. Try one or more of the following:

### CHECK THE COLLATE SETTING

From the Finishing menu, make sure Collate is On. To access the Finishing menu, do one of the following:

- If the printer is on a network, access the Embedded Web Server by typing the printer IP address into the address field of your Web browser. From the Settings screen, click **Finishing Menu**.
- If the printer is connected to a computer by a USB or parallel cable, open the Local Printer Settings Utility for Windows or Printer Settings for Macintosh. One of these utilities installs with the printer software.

## CHECK THE PAPER TAB SETTINGS IN YOUR OPERATING SYSTEM

Open Print Properties in a Windows operating system or the print dialog in a Macintosh operating system. Make sure the “Page layout” setting for “Collate copies” is On, or the Collate check box is selected.

**Note:** Clearing the Collate check box overrides the setting in the Finishing menu.



## **REDUCE THE COMPLEXITY OF THE PRINT JOB**

Reduce the complexity of the print job by eliminating the number and size of fonts, the number and complexity of images, and the number of pages in the job.

## **MAKE SURE THE PRINTER HAS ENOUGH MEMORY**

Add printer memory.

# **Solving option problems**

## **Option does not operate correctly or quits after it is installed**

These are possible solutions. Try one or more of the following:

### **RESET THE PRINTER**

Turn the printer off, wait for about 10 seconds, and then turn the printer on.

### **CHECK TO SEE IF THE OPTION IS CONNECTED TO THE PRINTER**

- 1 Turn the printer off.
- 2 Unplug the printer.
- 3 Check the connection between the option and the printer.

### **MAKE SURE THE OPTION IS INSTALLED**

Print a menu settings page and check to see if the option is listed in the Installed Options list. If the option is not listed, reinstall it.

### **MAKE SURE THE OPTION IS SELECTED**

From the program you are using, select the option. Mac OS 9 users should make sure the printer is set up in the Chooser.

## **Drawers**

These are possible solutions. Try one or more of the following:

### **MAKE SURE THE PAPER IS LOADED CORRECTLY**

- 1 Pull the tray completely out.
- 2 Check for paper jams or misfeeds.
- 3 Make sure the guides are aligned against the edges of the paper.
- 4 Insert the tray.

## RESET THE PRINTER

Turn the printer off, wait about 10 seconds, and then turn the printer on.

## Memory card

Make sure the memory card is securely connected to the printer system board.

# Solving paper feed problems

## Paper frequently jams

These are possible solutions. Try one or more of the following:

### CHECK THE PAPER

Use recommended paper or specialty media. For more information, see “Paper and specialty media guide” on page 51.

### FLEX, FAN, AND STRAIGHTEN THE PAPER BEFORE LOADING IT IN THE TRAY



### MAKE SURE THERE IS NOT TOO MUCH PAPER IN THE TRAY

Make sure the stack of paper you load does not exceed the maximum stack height indicated in the tray.

### CHECK THE GUIDES

Move the guides in the tray to the correct positions for the paper size loaded.

### THE PAPER MAY HAVE ABSORBED MOISTURE DUE TO HIGH HUMIDITY

- Load paper from a fresh package.
- Store paper in its original wrapper until you use it.

## Paper jam lights remain on after jam is cleared

The paper path is not clear. Clear jammed paper from the entire paper path, and then close any open doors.

## Page that jammed does not reprint after the jam is cleared

Jam Recovery is set to Off. Do one of the following to set Jam Recovery to Auto or On:

- If the printer is on a network, access the Embedded Web Server:
  - 1 Type the printer IP address into the address field of your Web browser.



**Note:** If you do not know the IP address of the printer, print a network setup page and locate the IP address in the TCP/IP section.
  - 2 From the Settings tab, make sure Jam Recovery is set to Auto or On, and then click **Submit**.
- If the printer is connected to a computer by a USB or parallel cable, open the Local Printer Settings Utility for Windows or Printer Settings for Macintosh. One of these utilities installs with the printer software. From the Setup menu, make sure Jam Recovery is set to Auto or On.

## Solving print quality problems

The information in the following topics may help you solve print quality problems. If these suggestions still do not correct the problem, call Customer Support. You may have a printer part that requires adjustment or replacement.

### Isolating print quality problems

Print the print quality test pages to isolate print quality problems.

- 1 Turn the printer off, and then open the front door.
- 2 Press and hold  while turning the printer on.
- 3 Release .
- 4 Close the front door. The light sequence that represents the Home menu appears.

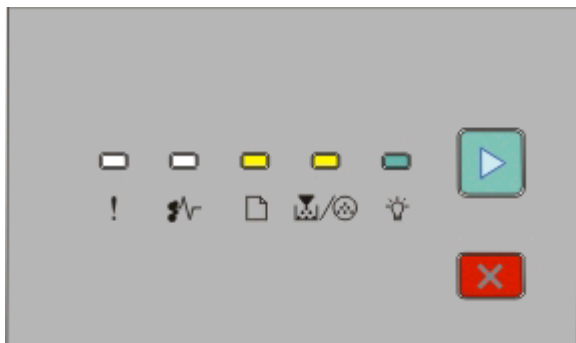



 - On

 /  - On

 - On

 - On

- 5 Press and release  until you see the light sequence for print quality test pages, as indicated on the printer settings configuration sheet.
- 6 Press and hold  until all lights cycle.

After a few minutes, the print quality test pages print. The pages include:

- An information page containing information about the device, the cartridge, margin settings, and minimum stroke width, and a graphic for evaluating the print quality
- Two pages for assessing how well the printer is capable of printing various types of graphics

**7** Examine the pages to determine the quality of printing. If there are problems, see “Solving print quality problems” on page 131.

To return to the Home menu, press and hold  until all the lights cycle. To exit the menus, turn the printer off.

## Blank pages

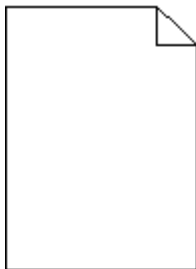

Try one or more of the following:

- Remove and reinstall the toner cartridge.
- Remove and reinstall the photoconductor kit.

If the printer still prints blank pages, it may need to be serviced. For more information, contact Customer Support.

## Characters have jagged or uneven edges

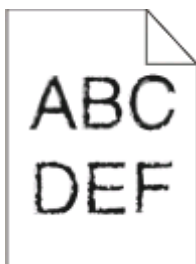

If you are using downloaded fonts, verify that the fonts are supported by the printer, the host computer, and the software program.

## Clipped images

These are possible solutions. Try one or more of the following:

### CHECK THE PAPER GUIDES

Move the guides in the tray to the correct positions for the paper size loaded.

### CHECK THE PAPER SIZE SETTING

Make sure the Paper Size setting matches the paper loaded in the tray.

## Gray background

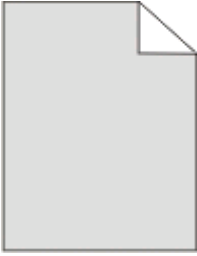

From the Quality menu, select a reduced Toner Darkness setting before sending the job to print. To access the Quality menu, do one of the following:

- If the printer is on a network, access the Embedded Web Server by typing the printer IP address into the address field of your Web browser. From the Settings tab, click **Print Settings**.
- If the printer is connected to a computer by a USB or parallel cable, open the Local Printer Settings Utility for Windows or Printer Settings for Macintosh. One of these utilities installs with the printer software.

## Ghost images



These are possible solutions. Try one or more of the following:

### **THE PHOTOCONDUCTOR KIT MAY BE DEFECTIVE**

Replace the photoconductor kit.

### **CHECK THE PAPER SIZE AND PAPER TYPE SETTINGS**

From the Paper menu, change the paper size and paper type settings to match the paper loaded in the tray. To access the Paper menu, do one of the following:

- If the printer is on a network, access the Embedded Web Server by typing the printer IP address in the address field of your Web browser. From the Settings tab, click **Paper Menu**.
- If the printer is connected to a computer by a USB or parallel cable, open the Local Printer Settings Utility for Windows or Printer Settings for Macintosh. One of these utilities installs with the printer software.

## Incorrect margins



### CHECK THE PAPER GUIDES

Move the guides in the tray to the correct positions for the paper size loaded.

### CHECK THE PAPER SIZE SETTING

Make sure the Paper Size setting matches the paper loaded in the tray.

### CHECK THE PAGE SIZE SETTING

Before sending the job to print, specify the correct page size in Print Properties or the software program.

## Paper curl

These are possible solutions. Try one or more of the following:

### CHECK THE PAPER TYPE SETTING

Make sure the Paper Type setting matches the paper loaded in the tray.

### THE PAPER MAY HAVE ABSORBED MOISTURE DUE TO HIGH HUMIDITY

Try one or more of the following:

- Load paper from a fresh package.
- Store paper in its original wrapper until you use it.

## Print is too dark



These are possible solutions. Try one or more of the following:

## CHECK THE DARKNESS, BRIGHTNESS, AND CONTRAST SETTINGS

The Toner Darkness setting is too dark, the Brightness setting is too dark, or the Contrast setting is too high.

- From Print Properties, change these settings.

**Note:** This solution applies to Windows users only.

- From the Quality menu, change these settings.

## THE PAPER MAY HAVE ABSORBED MOISTURE DUE TO HIGH HUMIDITY

- Load paper from a fresh package.
- Store paper in its original wrapper until you use it.

## CHECK THE PAPER

Avoid textured paper with rough finishes.

## CHECK THE PAPER TYPE SETTING

Make sure the Paper Type setting matches the paper loaded in the tray.

## THE TONER CARTRIDGE MAY BE DEFECTIVE

Replace the toner cartridge.

## Print is too light



These are possible solutions. Try one or more of the following:

## CHECK THE DARKNESS, BRIGHTNESS, AND CONTRAST SETTINGS

The Toner Darkness setting is too light, the Brightness setting is too light, or the Contrast setting is too low.

- From Print Properties, change these settings.

**Note:** This solution applies to Windows users only.

- From the Quality menu, change these settings.

## THE PAPER MAY HAVE ABSORBED MOISTURE DUE TO HIGH HUMIDITY

- Load paper from a fresh package.
- Store paper in its original wrapper until you use it.

## CHECK THE PAPER

Avoid textured paper with rough finishes.

## CHECK THE PAPER TYPE SETTING

Make sure the Paper Type setting matches the paper loaded in the tray.

## THE TONER MAY BE LOW

When **Toner is low** appears on the virtual display, or when the print becomes faded, order a new toner cartridge.

## THE TONER CARTRIDGE MAY BE DEFECTIVE

Replace the toner cartridge.

## Skewed print

### CHECK THE PAPER GUIDES

Move the guides in the tray to the correct positions for the paper size loaded.

### CHECK THE PAPER

Make sure you are using paper that meets the printer specifications.

## Toner fog or background shading appears on the page

These are possible solutions. Try one or more of the following:

### THE TONER CARTRIDGE MAY BE DEFECTIVE

Replace the toner cartridge.

### THERE IS TONER IN THE PAPER PATH

Contact Customer Support.

## Toner rubs off



These are possible solutions. Try one or more of the following:



## **CHECK THE PAPER TYPE SETTING**

Make sure the Paper Type setting matches the paper loaded in the tray.

## **CHECK THE PAPER TEXTURE SETTING**

Make sure the Paper Texture setting matches the paper loaded in the tray.

## **Toner specks**

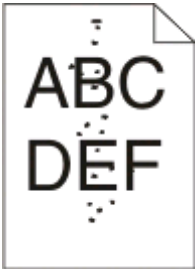

These are possible solutions. Try one or more of the following:

### **THE TONER CARTRIDGE MAY BE DEFECTIVE**

Replace the toner cartridge.

### **THERE IS TONER IN THE PAPER PATH**

Contact Customer Support.

## **Transparency print quality is poor**

### **CHECK THE TRANSPARENCIES**

Use only transparencies recommended by the printer manufacturer.

### **CHECK THE PAPER TYPE SETTING**

Load transparencies, and make sure the Paper Type setting is set to Transparency.

## **Streaked horizontal lines**



These are possible solutions. Try one or more of the following:

## THE TONER MAY SMEAR WHEN PAPER IS FED FROM A SPECIFIC SOURCE

From Print Properties, the print dialog, or the printer control panel, select another tray or feeder to feed the paper for the job.

## THE TONER CARTRIDGE MAY BE DEFECTIVE

Replace the toner cartridge.

## MAKE SURE THE PAPER PATH IS CLEAR

Paper could be caught between the photoconductor kit and the fuser. Check the paper path around the fuser area.

 **CAUTION—HOT SURFACE:** The area of the printer near the fuser is hot. Allow the area to cool before removing paper from this area.

Clear any paper you see.

## THERE MAY BE EXCESS TONER IN THE PAPER PATH

Contact Customer Support.

## Streaked vertical lines

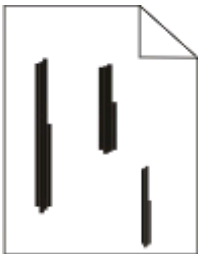

These are possible solutions. Try one or more of the following:

## THE TONER MAY SMEAR WHEN PAPER IS FED FROM A SPECIFIC SOURCE

From Print Properties, the print dialog, or the printer control panel, select another tray or feeder to feed paper for the job.

## THE TONER CARTRIDGE IS DEFECTIVE

Replace the toner cartridge.

## MAKE SURE THE PAPER PATH IS CLEAR

Paper could be caught between the photoconductor kit and the fuser. Check the paper path around the fuser area.

**Warning—Potential Damage:** Do not touch the photoconductor on the underside of the photoconductor kit. Use the cartridge handle whenever you are holding the cartridge.

 **CAUTION—HOT SURFACE:** The fuser and the inside of the printer near the fuser may be hot. To reduce the risk of injury from a hot component, allow the surface to cool before removing paper from this area.

Clear any paper you see.

## **THERE MAY BE EXCESS TONER IN THE PAPER PATH**

Contact Customer Support.

## **Solid black or white streaks appear on transparencies or paper**

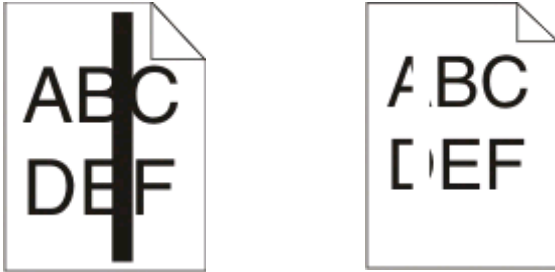

These are possible solutions. Try one or more of the following:

### **MAKE SURE THE FILL PATTERN IS CORRECT**

If the fill pattern is incorrect, choose a different fill pattern from your software program.

### **CHECK THE PAPER TYPE**

- Try a different type of paper.
- For transparencies, use only ones recommended by the printer manufacturer.
- Make sure the Paper Type setting matches what is loaded in the tray or feeder.
- Make sure the Paper Texture setting is correct for the type of paper or specialty media loaded in the tray or feeder.

### **MAKE SURE THE TONER IS DISTRIBUTED EVENLY IN THE TONER CARTRIDGE**

Remove the toner cartridge and shake it from side to side to redistribute the toner to extend the life of the cartridge, and then reinstall it.

### **THE TONER CARTRIDGE MAY BE DEFECTIVE OR LOW ON TONER**

Replace the used toner cartridge with a new one.

## **Contacting Customer Support**

When you call Customer Support, describe the problem you are experiencing, the message on the display, and the troubleshooting steps you have already taken to find a solution.

You need to know your printer model type and serial number. For more information, see the label on the inside top front cover of the printer. The serial number is also listed on the menu settings page.

In the U.S. or Canada, call (1-800-539-6275). For other countries/regions, visit the Lexmark Web site at [www.lexmark.com](http://www.lexmark.com).

# Notices

## Product information

Product name:

Lexmark E260, E260d, E260dn

Machine type:

4513

Model(s):

200, 220, 230

Machine type:

4562-d01, 4562-d02, 4562-gd1, 4562-gd2

4563-dn1, 4563-dn2, 4563-gd1, 4563-gd2

## Edition notice

May 2008

**The following paragraph does not apply to any country where such provisions are inconsistent with local law:** LEXMARK INTERNATIONAL, INC., PROVIDES THIS PUBLICATION "AS IS" WITHOUT WARRANTY OF ANY KIND, EITHER EXPRESS OR IMPLIED, INCLUDING, BUT NOT LIMITED TO, THE IMPLIED WARRANTIES OF MERCHANTABILITY OR FITNESS FOR A PARTICULAR PURPOSE. Some states do not allow disclaimer of express or implied warranties in certain transactions; therefore, this statement may not apply to you.

This publication could include technical inaccuracies or typographical errors. Changes are periodically made to the information herein; these changes will be incorporated in later editions. Improvements or changes in the products or the programs described may be made at any time.

References in this publication to products, programs, or services do not imply that the manufacturer intends to make these available in all countries in which it operates. Any reference to a product, program, or service is not intended to state or imply that only that product, program, or service may be used. Any functionally equivalent product, program, or service that does not infringe any existing intellectual property right may be used instead. Evaluation and verification of operation in conjunction with other products, programs, or services, except those expressly designated by the manufacturer, are the user's responsibility.

For Lexmark technical support, visit [support.lexmark.com](http://support.lexmark.com).

For information on supplies and downloads, visit [www.lexmark.com](http://www.lexmark.com).

If you don't have access to the Internet, you can contact Lexmark by mail:

Lexmark International, Inc.  
Bldg 004-2/CSC  
740 New Circle Road NW  
Lexington, KY 40550  
USA

© 2008 Lexmark International, Inc.

**All rights reserved.**

## **UNITED STATES GOVERNMENT RIGHTS**

This software and any accompanying documentation provided under this agreement are commercial computer software and documentation developed exclusively at private expense.

## **Trademarks**

Lexmark and Lexmark with diamond design are trademarks of Lexmark International, Inc., registered in the United States and/or other countries.

PCL® is a registered trademark of the Hewlett-Packard Company.

All other trademarks are the property of their respective owners.

## **Federal Communications Commission (FCC) compliance information statement**

This product has been tested and found to comply with the limits for a Class B digital device, pursuant to Part 15 of the FCC Rules. Operation is subject to the following two conditions: (1) this device may not cause harmful interference, and (2) this device must accept any interference received, including interference that may cause undesired operation

The FCC Class B limits are designed to provide reasonable protection against harmful interference when the equipment is operated in a residential installation. This equipment generates, uses, and can radiate radio frequency energy and, if not installed and used in accordance with the instructions, may cause harmful interference to radio communications. However, there is no guarantee that interference will not occur in a particular installation. If this equipment does cause harmful interference to radio or television reception, which can be determined by turning the equipment off and on, the user is encouraged to try to correct the interference by one or more of the following measures:

- Reorient or relocate the receiving antenna.
- Increase the separation between the equipment and receiver.
- Connect the equipment into an outlet on a circuit different from that to which the receiver is connected.
- Consult your point of purchase or service representative for additional suggestions.

The manufacturer is not responsible for radio or television interference caused by using other than recommended cables or by unauthorized changes or modifications to this equipment. Unauthorized changes or modifications could void the user's authority to operate this equipment.

**Note:** To assure compliance with FCC regulations on electromagnetic interference for a Class B computing device, use a properly shielded and grounded cable such as Lexmark part number 1021231 for parallel attach or 1021294 for USB attach. Use of a substitute cable not properly shielded and grounded may result in a violation of FCC regulations.

Any questions regarding this compliance information statement should be directed to:

Director of Lexmark Technology & Services  
Lexmark International, Inc.  
740 West New Circle Road  
Lexington, KY 40550  
(859) 232-3000

## Industry Canada compliance statement

This Class B digital apparatus meets all requirements of the Canadian Interference-Causing Equipment Standard ICES-003.

## Avis de conformité aux normes de l'industrie du Canada

Cet appareil numérique de classe B est conforme aux exigences de la norme canadienne relative aux équipements pouvant causer des interférences NMB-003.

## European Community (EC) directives conformity

This product is in conformity with the protection requirements of EC Council directives 2004/108/EC and 2006/95/EC on the approximation and harmonization of the laws of the Member States relating to electromagnetic compatibility and safety of electrical equipment designed for use within certain voltage limits.

A declaration of conformity with the requirements of the directives has been signed by the Director of Manufacturing and Technical Support, Lexmark International, Inc., S.A., Boigny, France.

This product satisfies the Class B limits of EN 55022 and safety requirements of EN 60950.

**The following notices are applicable if your printer has a wireless network card installed**

## Exposure to radio frequency radiation

The radiated output power of this device is far below the radio frequency exposure limits of the FCC and other regulatory agencies. A minimum separation of 20 cm (8 inches) must be maintained between the antenna and any persons for this device to satisfy the RF exposure requirements of the FCC and other regulatory agencies.

## Industry Canada notice

The following notices are applicable if your printer has a wireless network card installed.

### Industry Canada (Canada)

This device complies with Industry Canada specification RSS-210. Operation is subject to the following two conditions: (1) this device may not cause interference, and (2) this device must accept any interference, including interference that may cause undesired operation of the device.

This device has been designed to operate only with the antenna provided. Use of any other antenna is strictly prohibited per regulations of Industry Canada.

To prevent radio interference to the licensed service, this device is intended to be operated indoors and away from windows to provide maximum shielding. Equipment (or its transmit antenna) that is installed outdoors is subject to licensing.

The installer of this radio equipment must ensure that the antenna is located or pointed such that it does not emit RF fields in excess of Health Canada limits for the general population; consult Safety Code 6, obtainable from Health Canada's Web site [www.hc-sc.gc.ca/rpb](http://www.hc-sc.gc.ca/rpb).

The term "IC:" before the certification/registration number only signifies that the Industry Canada technical specifications were met.

## **Industry Canada (Canada)**

Cet appareil est conforme à la norme RSS-210 d'Industry Canada. Son fonctionnement est soumis aux deux conditions suivantes :

(1) cet appareil ne doit pas provoquer d'interférences et (2) il doit accepter toute interférence reçue, y compris celles risquant d'altérer son fonctionnement.

Cet appareil a été conçu pour fonctionner uniquement avec l'antenne fournie. L'utilisation de toute autre antenne est strictement interdite par la réglementation d'Industry Canada.

En application des réglementations d'Industry Canada, l'utilisation d'une antenne de gain supérieur est strictement interdite.

Pour empêcher toute interférence radio au service faisant l'objet d'une licence, cet appareil doit être utilisé à l'intérieur et loin des fenêtres afin de garantir une protection optimale.

Si le matériel (ou son antenne d'émission) est installé à l'extérieur, il doit faire l'objet d'une licence.

L'installateur de cet équipement radio doit veiller à ce que l'antenne soit implantée et dirigée de manière à n'émettre aucun champ HF dépassant les limites fixées pour l'ensemble de la population par Santé Canada. Reportez-vous au Code de sécurité 6 que vous pouvez consulter sur le site Web de Santé Canada [www.hc-sc.gc.ca/rpb](http://www.hc-sc.gc.ca/rpb).

Le terme « IC » précédant le numéro de d'accréditation/inscription signifie simplement que le produit est conforme aux spécifications techniques d'Industry Canada.

## **European Community (EC) directives conformity statement for radio products**

This product is in conformity with the protection requirements of EC Council directives 2004/108/EC, 2006/95/EC, and 1999/5/EC on the approximation and harmonization of the laws of the Member States relating to electromagnetic compatibility, safety of electrical equipment designed for use within certain voltage limits and on radio equipment and telecommunications terminal equipment.

Compliance is indicated by the CE marking.



Operation is allowed in all EU and EFTA countries, but is restricted to indoor use only.

A declaration of conformity with the requirements of the directives is available from the Director of Manufacturing and Technical Support, Lexmark International, S. A., Boigny, France.

This product satisfies the limits of EN 55022; safety requirements of EN 60950; radio spectrum requirements of ETSI EN 300 328; and the EMC requirements of EN 55024, ETSI EN 301 489-1 and ETSI EN 301 489-17.

Česky	Společnost Lexmark International, Inc. tímto prohlašuje, že výrobek tento výrobek je ve shodě se základními požadavky a dalšími příslušnými ustanoveními směrnice 1999/5/ES.
Dansk	Lexmark International, Inc. erklærer herved, at dette produkt overholder de væsentlige krav og øvrige relevante krav i direktiv 1999/5/EF.
Deutsch	Hiermit erklärt Lexmark International, Inc., dass sich das Gerät dieses Gerät in Übereinstimmung mit den grundlegenden Anforderungen und den übrigen einschlägigen Bestimmungen der Richtlinie 1999/5/EG befindet.
Ελληνική	ΜΕ ΤΗΝ ΠΑΡΟΥΣΑ Η LEXMARK INTERNATIONAL, INC. ΔΗΛΩΝΕΙ ΟΤΙ ΑΥΤΟ ΤΟ ΠΡΟΪΟΝ ΣΥΜΜΟΡΦΩΝΕΤΑΙ ΠΡΟΣ ΤΙΣ ΟΥΣΙΩΔΕΙΣ ΑΠΑΙΤΗΣΕΙΣ ΚΑΙ ΤΙΣ ΛΟΙΠΕΣ ΣΧΕΤΙΚΕΣ ΔΙΑΤΑΞΕΙΣ ΤΗΣ ΟΔΗΓΙΑΣ 1999/5/ΕΚ.
English	Hereby, Lexmark International, Inc., declares that this type of equipment is in compliance with the essential requirements and other relevant provisions of Directive 1999/5/EC.
Español	Por medio de la presente, Lexmark International, Inc. declara que este producto cumple con los requisitos esenciales y cualesquiera otras disposiciones aplicables o exigibles de la Directiva 1999/5/CE.
Eesti	Käesolevaga kinnitab Lexmark International, Inc., et seade see toode vastab direktiivi 1999/5/EÜ põhinõuetele ja nimetatud direktiivist tulenevatele muudele asjakohastele sätetele.
Suomi	Lexmark International, Inc. vakuuttaa täten, että tämä tuote on direktiivin 1999/5/EY oleellisten vaatimusten ja muiden sitä koskevien direktiivin ehtojen mukainen.
Français	Par la présente, Lexmark International, Inc. déclare que l'appareil ce produit est conforme aux exigences fondamentales et autres dispositions pertinentes de la directive 1999/5/CE.
Magyar	Alulírott, Lexmark International, Inc. nyilatkozom, hogy a termék megfelel a vonatkozó alapvető követelményeknek és az 1999/5/EC irányelv egyéb előírásainak.
Íslenska	Hér með lýsir Lexmark International, Inc. yfir því að þessi vara er í samræmi við grunnkröfur og aðrar kröfur, sem gerðar eru í tilskipun 1999/5/EC.
Italiano	Con la presente Lexmark International, Inc. dichiara che questo questo prodotto è conforme ai requisiti essenziali ed alle altre disposizioni pertinenti stabilite dalla direttiva 1999/5/CE.
Latviski	Ar šo Lexmark International, Inc. deklarē, ka šis izstrādājums atbilst Direktīvas 1999/5/EK būtiskajām prasībām un citiem ar to saistītajiem noteikumiem.
Lietuvių	Šiuo Lexmark International, Inc. deklaruoja, kad šis produktas atitinka esminius reikalavimus ir kitas 1999/5/EB direktyvos nuostatas.
Malti	Bil-preżenti, Lexmark International, Inc., jiddikjara li dan il-prodott huwa konformi mal-ħtiġijiet essenzjali u ma dispożizzjonijiet oħrajn relevanti li jinsabu fid-Direttiva 1999/5/KE.
Nederlands	Hierbij verklaart Lexmark International, Inc. dat het toestel dit product in overeenstemming is met de essentiële eisen en de andere relevante bepalingen van richtlijn 1999/5/EG.
Norsk	Lexmark International, Inc. erklærer herved at dette produktet er i samsvar med de grunnleggende krav og øvrige relevante krav i direktiv 1999/5/EF.
Polski	Niniejszym Lexmark International, Inc. oświadcza, że niniejszy produkt jest zgodny z zasadniczymi wymogami oraz pozostałymi stosownymi postanowieniami Dyrektywy 1999/5/EC.
Português	A Lexmark International Inc. declara que este este produto está conforme com os requisitos essenciais e outras disposições da Diretiva 1999/5/CE.



Slovensky	Lexmark International, Inc. týmto vyhlasuje, že tento produkt spĺňa základné požiadavky a všetky príslušné ustanovenia smernice 1999/5/ES.
Slovensko	Lexmark International, Inc. izjavlja, da je ta izdelek v skladu z bistvenimi zahtevami in ostalimi relevantnimi določili direktive 1999/5/ES.
Svenska	Härmed intygar Lexmark International, Inc. att denna produkt står i överensstämmelse med de väsentliga egenskapskrav och övriga relevanta bestämmelser som framgår av direktiv 1999/5/EG.

## Noise emission levels

The following measurements were made in accordance with ISO 7779 and reported in conformance with ISO 9296.

**Note:** Some modes may not apply to your product.

1-meter average sound pressure, dBA	
Printing	52 dBA
Ready	N/A

Values are subject to change. See [www.lexmark.com](http://www.lexmark.com) for current values.

## Waste from Electrical and Electronic Equipment (WEEE) directive



The WEEE logo signifies specific recycling programs and procedures for electronic products in countries of the European Union. We encourage the recycling of our products. If you have further questions about recycling options, visit the Lexmark Web site at [www.lexmark.com](http://www.lexmark.com) for your local sales office phone number.

## Static sensitivity notice



This symbol identifies static-sensitive parts. Do not touch in the areas near these symbols without first touching the metal frame of the printer.

## ENERGY STAR

Applicable only to models with duplexing enabled.



## Laser notice

The printer is certified in the U.S. to conform to the requirements of DHHS 21 CFR Subchapter J for Class I (1) laser products, and elsewhere is certified as a Class I laser product conforming to the requirements of IEC 60825-1.

Class I laser products are not considered to be hazardous. The printer contains internally a Class IIIb (3b) laser that is nominally a 7 milliwatt gallium arsenide laser operating in the wavelength of 655-675 nanometers. The laser system and printer are designed so there is never any human access to laser radiation above a Class I level during normal operation, user maintenance, or prescribed service condition.

## Laser advisory label

A laser notice label may be affixed to this printer as shown:



## Power consumption

### Product power consumption

The following table documents the power consumption characteristics of the product.

**Note:** Some modes may not apply to your product.

Mode	Description	Power consumption (Watts)
Printing	The product is generating hard-copy output from electronic inputs.	470 W
Copying	The product is generating hard-copy output from hard-copy original documents.	N/A
Scanning	The product is scanning hard-copy documents.	N/A
Ready	The product is waiting for a print job.	12 W
Power Saver	The product is in energy-saving mode.	11 W
Off	The product is plugged into a wall outlet, but the power switch is turned off.	N/A

The power consumption levels listed in the previous table represent time-averaged measurements. Instantaneous power draws may be substantially higher than the average.

Values are subject to change. See [www.lexmark.com](http://www.lexmark.com) for current values.

## Power Saver

This product is designed with an energy-saving mode called Power Saver. The Power Saver Mode is equivalent to the EPA Sleep Mode. The Power Saver Mode saves energy by lowering power consumption during extended periods of inactivity. The Power Saver Mode is automatically engaged after this product is not used for a specified period of time, called the Power Saver Timeout.

Factory default Power Saver Timeout for this product (in minutes):	30 min.
--------------------------------------------------------------------	---------

By using the configuration menus, the Power Saver Timeout can be modified between 1 minute and 240 minutes. Setting the Power Saver Timeout to a low value reduces energy consumption, but may increase the response time of the product. Setting the Power Saver Timeout to a high value maintains a fast response, but uses more energy.

## Off mode

If this product has an off mode which still consumes a small amount of power, then to completely stop product power consumption, disconnect the power supply cord from the wall outlet.

## Total energy usage

It is sometimes helpful to calculate the total product energy usage. Since power consumption claims are provided in power units of Watts, the power consumption should be multiplied by the time the product spends in each mode in order to calculate energy usage. The total product energy usage is the sum of each mode's energy usage.

## Statement of Limited Warranty

Lexmark E260, E260d, E260dn

### Lexmark International, Inc., Lexington, KY

This limited warranty applies to the United States and Canada. For customers outside the U.S., refer to the country-specific warranty information that came with your product.

This limited warranty applies to this product only if it was originally purchased for your use, and not for resale, from Lexmark or a Lexmark Remarketer, referred to in this statement as "Remarketer."

### Limited warranty

Lexmark warrants that this product:

- Is manufactured from new parts, or new and serviceable used parts, which perform like new parts
- Is, during normal use, free from defects in material and workmanship

If this product does not function as warranted during the warranty period, contact a Remarketer or Lexmark for repair or replacement (at Lexmark's option).

If this product is a feature or option, this statement applies only when that feature or option is used with the product for which it was intended. To obtain warranty service, you may be required to present the feature or option with the product.

If you transfer this product to another user, warranty service under the terms of this statement is available to that user for the remainder of the warranty period. You should transfer proof of original purchase and this statement to that user.

## Limited warranty service

The warranty period starts on the date of original purchase as shown on the purchase receipt and ends 12 months later provided that the warranty period for any supplies and for any maintenance items included with the printer shall end earlier if it, or its original contents, are substantially used up, depleted, or consumed.

To obtain warranty service you may be required to present proof of original purchase. You may be required to deliver your product to the Remarketer or Lexmark, or ship it prepaid and suitably packaged to a Lexmark designated location. You are responsible for loss of, or damage to, a product in transit to the Remarketer or the Lexmark designated location.

When warranty service involves the exchange of a product or part, the item replaced becomes the property of the Remarketer or Lexmark. The replacement may be a new or repaired item.

The replacement item assumes the remaining warranty period of the original product.

Replacement is not available to you if the product you present for exchange is defaced, altered, in need of a repair not included in warranty service, damaged beyond repair, or if the product is not free of all legal obligations, restrictions, liens, and encumbrances.

Before you present this product for warranty service, remove all print cartridges, programs, data, and removable storage media (unless directed otherwise by Lexmark).

For further explanation of your warranty alternatives and the nearest Lexmark authorized servicer in your area contact Lexmark on the World Wide Web at [www.lexmark.com/support](http://www.lexmark.com/support).

Remote technical support is provided for this product throughout its warranty period. For products no longer covered by a Lexmark warranty, technical support may not be available or only be available for a fee.

## Extent of limited warranty

Lexmark does not warrant uninterrupted or error-free operation of any product or the durability or longevity of prints produced by any product.

Warranty service does not include repair of failures caused by:

- Modification or unauthorized attachments
- Accidents, misuse, abuse or use inconsistent with Lexmark user's guides, manuals, instructions or guidance
- Unsuitable physical or operating environment
- Maintenance by anyone other than Lexmark or a Lexmark authorized servicer
- Operation of a product beyond the limit of its duty cycle
- Use of printing media outside of Lexmark specifications
- Refurbishment, repair, refilling or remanufacture by a third party of products, supplies or parts
- Products, supplies, parts, materials (such as toners and inks), software, or interfaces not furnished by Lexmark

**TO THE EXTENT PERMITTED BY APPLICABLE LAW, NEITHER LEXMARK NOR ITS THIRD PARTY SUPPLIERS OR REMARKETERS MAKE ANY OTHER WARRANTY OR CONDITION OF ANY KIND, WHETHER EXPRESS OR IMPLIED, WITH RESPECT TO THIS PRODUCT, AND SPECIFICALLY DISCLAIM THE IMPLIED WARRANTIES OR CONDITIONS OF MERCHANTABILITY, FITNESS FOR A PARTICULAR PURPOSE, AND SATISFACTORY QUALITY. ANY WARRANTIES THAT MAY NOT BE DISCLAIMED UNDER APPLICABLE LAW ARE LIMITED IN DURATION TO THE WARRANTY PERIOD. NO WARRANTIES, EXPRESS OR IMPLIED, WILL APPLY AFTER THIS PERIOD. ALL INFORMATION, SPECIFICATIONS, PRICES, AND SERVICES ARE SUBJECT TO CHANGE AT ANY TIME WITHOUT NOTICE.**

### **Limitation of liability**

Your sole remedy under this limited warranty is set forth in this document. For any claim concerning performance or nonperformance of Lexmark or a Remarketer for this product under this limited warranty, you may recover actual damages up to the limit set forth in the following paragraph.

Lexmark's liability for actual damages from any cause whatsoever will be limited to the amount you paid for the product that caused the damages. This limitation of liability will not apply to claims by you for bodily injury or damage to real property or tangible personal property for which Lexmark is legally liable. **IN NO EVENT WILL LEXMARK BE LIABLE FOR ANY LOST PROFITS, LOST SAVINGS, INCIDENTAL DAMAGE, OR OTHER ECONOMIC OR CONSEQUENTIAL DAMAGES.** This is true even if you advise Lexmark or a Remarketer of the possibility of such damages. Lexmark is not liable for any claim by you based on a third party claim.

This limitation of remedies also applies to claims against any Suppliers and Remarketers of Lexmark. Lexmark's and its Suppliers' and Remarketers' limitations of remedies are not cumulative. Such Suppliers and Remarketers are intended beneficiaries of this limitation.

### **Additional rights**

Some states do not allow limitations on how long an implied warranty lasts, or do not allow the exclusion or limitation of incidental or consequential damages, so the limitations or exclusions contained above may not apply to you.

This limited warranty gives you specific legal rights. You may also have other rights that vary from state to state.

## **LEXMARK SOFTWARE LIMITED WARRANTY AND LICENSE AGREEMENT**

PLEASE READ CAREFULLY BEFORE USING THIS PRODUCT: This License Agreement ("Software License Agreement") is a legal agreement between you (either an individual or a single entity) and Lexmark International, Inc. ("Lexmark") that, to the extent your Lexmark product or Software Program is not otherwise subject to a written software license agreement between you and Lexmark or its suppliers, governs your use of any Software Program installed on or provided by Lexmark for use in connection with your Lexmark product. The term "Software Program" includes machine-readable instructions, audio/visual content (such as images and recordings), and associated media, printed materials and electronic documentation, whether incorporated into, distributed with or for use with your Lexmark product.

BY USING THIS PRODUCT, YOU AGREE TO BE BOUND BY ALL THE TERMS AND CONDITIONS OF THIS SOFTWARE LIMITED WARRANTY AND LICENSE AGREEMENT. IF YOU DO NOT AGREE WITH THE TERMS OF THIS SOFTWARE LIMITED WARRANTY AND LICENSE AGREEMENT, PROMPTLY RETURN THE PRODUCT UNUSED AND REQUEST A REFUND OF THE AMOUNT YOU PAID. IF YOU ARE INSTALLING THIS PRODUCT FOR USE BY OTHER PARTIES, YOU AGREE TO INFORM THE USERS THAT USE OF THE PRODUCT INDICATES ACCEPTANCE OF THESE TERMS.

**1 STATEMENT OF SOFTWARE LIMITED WARRANTY.** Lexmark warrants that the media (e.g., diskette or compact disk) on which the Software Program (if any) is furnished is free from defects in materials and workmanship under normal use during the warranty period. The warranty period is ninety (90) days and commences on the date the Software Program is delivered to the original end-user. This limited warranty applies only to Software Program media purchased new from Lexmark or an Authorized Lexmark Reseller or Distributor. Lexmark will replace the Software Program should it be determined that the media does not conform to this limited warranty.

**2 DISCLAIMER AND LIMITATION OF WARRANTIES.** EXCEPT AS PROVIDED IN THIS SOFTWARE LICENSE AGREEMENT AND TO THE MAXIMUM EXTENT PERMITTED BY APPLICABLE LAW, LEXMARK AND ITS SUPPLIERS PROVIDE THE SOFTWARE PROGRAM "AS IS" AND HEREBY DISCLAIM ALL OTHER WARRANTIES AND CONDITIONS, EITHER EXPRESS OR IMPLIED, INCLUDING, BUT NOT LIMITED TO, TITLE, NON-INFRINGEMENT, MERCHANTABILITY AND FITNESS FOR A PARTICULAR PURPOSE, AND ABSENCE OF VIRUSES, ALL WITH REGARD TO THE SOFTWARE PROGRAM. TO THE EXTENT LEXMARK CANNOT BY LAW DISCLAIM ANY COMPONENT OF THE IMPLIED WARRANTIES OF MERCHANTABILITY OR FITNESS FOR A PARTICULAR PURPOSE, LEXMARK LIMITS THE DURATION OF SUCH WARRANTIES TO THE 90-DAY TERM OF THE EXPRESS SOFTWARE LIMITED WARRANTY.

This Agreement is to be read in conjunction with certain statutory provisions, as that may be in force from time to time, that imply warranties or conditions or impose obligations on Lexmark that cannot be excluded or modified. If any such provisions apply, then to the extent Lexmark is able, Lexmark hereby limits its liability for breach of those provisions to one of the following: providing you a replacement copy of the Software Program or reimbursement of the price paid for the Software Program.

The Software Program may include internet links to other software applications and/or internet web pages hosted and operated by third parties unaffiliated with Lexmark. You acknowledge and agree that Lexmark is not responsible in any way for the hosting, performance, operation, maintenance, or content of, such software applications and/or internet web pages.

**3 LIMITATION OF REMEDY.** TO THE MAXIMUM EXTENT PERMITTED BY APPLICABLE LAW, ANY AND ALL LIABILITY OF LEXMARK UNDER THIS SOFTWARE LICENSE AGREEMENT IS EXPRESSLY LIMITED TO THE GREATER OF THE PRICE PAID FOR THE SOFTWARE PROGRAM AND FIVE U.S. DOLLARS (OR THE EQUIVALENT IN LOCAL CURRENCY). YOUR SOLE REMEDY AGAINST LEXMARK IN ANY DISPUTE UNDER THIS SOFTWARE LICENSE AGREEMENT SHALL BE TO SEEK TO RECOVER ONE OF THESE AMOUNTS, UPON PAYMENT OF WHICH LEXMARK SHALL BE RELEASED AND DISCHARGED OF ALL FURTHER OBLIGATIONS AND LIABILITY TO YOU.

IN NO EVENT WILL LEXMARK, ITS SUPPLIERS, SUBSIDIARIES, OR RESELLERS BE LIABLE FOR ANY SPECIAL, INCIDENTAL, INDIRECT, EXEMPLARY, PUNITIVE, OR CONSEQUENTIAL DAMAGES (INCLUDING BUT NOT LIMITED TO LOST PROFITS OR REVENUES, LOST SAVINGS, INTERRUPTION OF USE OR ANY LOSS OF, INACCURACY IN, OR DAMAGE TO, DATA OR RECORDS, FOR CLAIMS OF THIRD PARTIES, OR DAMAGE TO REAL OR TANGIBLE PROPERTY, FOR LOSS OF PRIVACY ARISING OUT OR IN ANY WAY RELATED TO THE USE OF OR INABILITY TO USE THE SOFTWARE PROGRAM, OR OTHERWISE IN CONNECTION WITH ANY PROVISION OF THIS SOFTWARE LICENSE AGREEMENT), REGARDLESS OF THE NATURE OF THE CLAIM, INCLUDING BUT NOT LIMITED TO BREACH OF WARRANTY OR CONTRACT, TORT (INCLUDING NEGLIGENCE OR STRICT LIABILITY), AND EVEN IF LEXMARK, OR ITS SUPPLIERS, AFFILIATES, OR REMARKETERS HAVE BEEN ADVISED OF THE POSSIBILITY OF SUCH DAMAGES, OR FOR ANY CLAIM BY YOU BASED ON A THIRD-PARTY CLAIM, EXCEPT TO THE EXTENT THIS EXCLUSION OF DAMAGES IS DETERMINED LEGALLY INVALID. THE FOREGOING LIMITATIONS APPLY EVEN IF THE ABOVE-STATED REMEDIES FAIL OF THEIR ESSENTIAL PURPOSE.

**4 U.S.A. STATE LAWS.** This Software Limited Warranty gives you specific legal rights. You may also have other rights that vary from state to state. Some states do not allow limitations on how long an implied warranty lasts or the exclusion of limitation of incidental or consequential damages, so the above limitations may not apply to you.

- 5 LICENSE GRANT.** Lexmark grants you the following rights provided you comply with all terms and conditions of this Software License Agreement:
- a Use.** You may Use one (1) copy of the Software Program. The term “Use” means storing, loading, installing, executing, or displaying the Software Program. If Lexmark has licensed the Software Program to you for concurrent use, you must limit the number of authorized users to the number specified in your agreement with Lexmark. You may not separate the components of the Software Program for use on more than one computer. You agree that you will not Use the Software Program, in whole or in part, in any manner that has the effect of overriding, modifying, eliminating, obscuring, altering or de-emphasizing the visual appearance of any trademark, trade name, trade dress or intellectual property notice that appears on any computer display screens normally generated by, or as a result of, the Software Program.
  - b Copying.** You may make one (1) copy of the Software Program solely for purposes of backup, archiving, or installation, provided the copy contains all of the original Software Program’s proprietary notices. You may not copy the Software Program to any public or distributed network.
  - c Reservation of Rights.** The Software Program, including all fonts, is copyrighted and owned by Lexmark International, Inc. and/or its suppliers. Lexmark reserves all rights not expressly granted to you in this Software License Agreement.
  - d Freeware.** Notwithstanding the terms and conditions of this Software License Agreement, all or any portion of the Software Program that constitutes software provided under public license by third parties (“Freeware”) is licensed to you subject to the terms and conditions of the software license agreement accompanying such Freeware, whether in the form of a discrete agreement, shrink-wrap license, or electronic license terms at the time of download or installation. Use of the Freeware by you shall be governed entirely by the terms and conditions of such license.
- 6 TRANSFER.** You may transfer the Software Program to another end-user. Any transfer must include all software components, media, printed materials, and this Software License Agreement and you may not retain copies of the Software Program or components thereof. The transfer may not be an indirect transfer, such as a consignment. Prior to the transfer, the end-user receiving the transferred Software Program must agree to all these Software License Agreement terms. Upon transfer of the Software Program, your license is automatically terminated. You may not rent, sublicense, or assign the Software Program except to the extent provided in this Software License Agreement.
- 7 UPGRADES.** To Use a Software Program identified as an upgrade, you must first be licensed to the original Software Program identified by Lexmark as eligible for the upgrade. After upgrading, you may no longer use the original Software Program that formed the basis for your upgrade eligibility.
- 8 LIMITATION ON REVERSE ENGINEERING.** You may not alter, decrypt, reverse engineer, reverse assemble, reverse compile or otherwise translate the Software Program or assist or otherwise facilitate others to do so, except as and to the extent expressly permitted to do so by applicable law for the purposes of inter-operability, error correction, and security testing. If you have such statutory rights, you will notify Lexmark in writing of any intended reverse engineering, reverse assembly, or reverse compilation. You may not decrypt the Software Program unless necessary for the legitimate Use of the Software Program.
- 9 ADDITIONAL SOFTWARE.** This Software License Agreement applies to updates or supplements to the original Software Program provided by Lexmark unless Lexmark provides other terms along with the update or supplement.
- 10 TERM.** This Software License Agreement is effective unless terminated or rejected. You may reject or terminate this license at any time by destroying all copies of the Software Program, together with all modifications, documentation, and merged portions in any form, or as otherwise described herein. Lexmark may terminate your license upon notice if you fail to comply with any of the terms of this Software License Agreement. Upon such termination, you agree to destroy all copies of the Software Program together with all modifications, documentation, and merged portions in any form.

- 11 TAXES.** You agree that you are responsible for payment of any taxes including, without limitation, any goods and services and personal property taxes, resulting from this Software License Agreement or your Use of the Software Program.
- 12 LIMITATION ON ACTIONS.** No action, regardless of form, arising out of this Software License Agreement may be brought by either party more than two years after the cause of action has arisen, except as provided under applicable law.
- 13 APPLICABLE LAW.** This Software License Agreement is governed by the laws of the Commonwealth of Kentucky, United States of America. No choice of law rules in any jurisdiction shall apply. The UN Convention on Contracts for the International Sale of Goods shall not apply.
- 14 UNITED STATES GOVERNMENT RESTRICTED RIGHTS.** The Software Program has been developed entirely at private expense. Rights of the United States Government to use the Software Program are as set forth in this Software License Agreement and as restricted in DFARS 252.227-7014 and in similar FAR provisions (or any equivalent agency regulation or contract clause).
- 15 CONSENT TO USE OF DATA.** You agree that Lexmark, its affiliates, and agents may collect and use information you provide in relation to support services performed with respect to the Software Program and requested by you. Lexmark agrees not to use this information in a form that personally identifies you except to the extent necessary to provide such services.
- 16 EXPORT RESTRICTIONS.** You may not (a) acquire, ship, transfer, or reexport, directly or indirectly, the Software Program or any direct product therefrom, in violation of any applicable export laws or (b) permit the Software Program to be used for any purpose prohibited by such export laws, including, without limitation, nuclear, chemical, or biological weapons proliferation.
- 17 AGREEMENT TO CONTRACT ELECTRONICALLY.** You and Lexmark agree to form this Software License Agreement electronically. This means that when you click the "Agree" or "I accept" button on this page or use this product, you acknowledge your agreement to these Software License Agreement terms and conditions and that you are doing so with the intent to "sign" a contract with Lexmark.
- 18 CAPACITY AND AUTHORITY TO CONTRACT.** You represent that you are of the legal age of majority in the place you sign this Software License Agreement and, if applicable, you are duly authorized by your employer or principal to enter into this contract.
- 19 ENTIRE AGREEMENT.** This Software License Agreement (including any addendum or amendment to this Software License Agreement that is included with the Software Program) is the entire agreement between you and Lexmark relating to the Software Program. Except as otherwise provided for herein, these terms and conditions supersede all prior or contemporaneous oral or written communications, proposals, and representations with respect to the Software Program or any other subject matter covered by this Software License Agreement (except to the extent such extraneous terms do not conflict with the terms of this Software License Agreement, any other written agreement signed by you and Lexmark relating to your Use of the Software Program). To the extent any Lexmark policies or programs for support services conflict with the terms of this Software License Agreement, the terms of this Software License Agreement shall control.

## **MICROSOFT CORPORATION NOTICES**

- 1** This product may incorporate intellectual property owned by Microsoft Corporation. The terms and conditions upon which Microsoft is licensing such intellectual property may be found at <http://go.microsoft.com/fwlink/?LinkId=52369>.
- 2** This product is based on Microsoft Print Schema technology. You may find the terms and conditions upon which Microsoft is licensing such intellectual property at <http://go.microsoft.com/fwlink/?LinkId=83288>.



# Index

## Numerics

200.yy Paper jam 96  
201.yy Paper jam 97  
202 paper jams, clearing  
    behind the rear door 124  
202.yy Paper jam 97  
231.yy Paper jam 97  
233.yy Paper jam 97  
234.yy Paper jam 98  
235 paper jams, clearing  
    from standard exit bin 120  
235.yy Paper jam 98  
24x.yy Paper jam 98  
250-sheet drawer  
    installing 17  
251 paper jams, clearing  
    from manual feeder 123  
251.yy Paper jam 98  
2-sided printing 58, 59  
31.yy Replace defective or missing  
cartridge 95  
32.yy Cartridge part number  
unsupported by device 95  
34 Short paper 95  
37 Insufficient memory to collate  
job 95  
38 Memory full 95  
39 Complex page, some data may  
not have printed 96  
42.xy Cartridge region  
mismatch 96  
54 Standard network software  
error 96  
550-sheet drawer  
    installing 17  
84 PC Kit life warning 96  
84 Replace PC Kit 96

## A

AppleTalk menu 88  
attaching cables 18

## B

booklet  
    printing 63  
both sides of paper (duplexing)  
    printing manually 59

Busy 93

## C

cables  
    Ethernet 18  
    parallel 18  
    USB 18  
calling Customer Support 139  
Canceling 93  
canceling a job  
    from the printer control panel 65  
canceling a print job  
    from Macintosh 65  
    from Windows 65  
card stock  
    tips 63  
checking an unresponsive  
printer 126  
checking device status  
    on Embedded Web Server 109  
checking virtual display  
    on Embedded Web Server 93  
cleaning  
    exterior of the printer 99  
Close front door 93  
collate setting  
    Finishing menu 70  
configurations  
    printer 9  
configuring  
    multiple printers 111  
configuring supply  
notifications 111  
conserving supplies 99  
contacting Customer Support 139  
control panel, printer 21, 28, 34  
    buttons 12  
    lights 12  
Custom Type <x>  
    changing name 50  
custom type name  
    assigning 49  
Custom Types menu 76

## D

Default Source menu 71  
documents, printing  
    from Macintosh 57

    from Windows 57  
duplex printing 58, 59  
    manual 59

## E

Embedded Web Server 68  
    copying settings to other  
    printers 111  
    restricting access to printer  
    menus 110  
    setting up e-mail alerts 110  
emission  
    notices 141, 142, 143, 144, 145  
envelopes  
    loading 46  
    tips 61  
Ethernet port 18  
exterior of the printer  
    cleaning 99  
e-mail  
    notice of low supply level 110  
    notice of paper jam 110  
    notice of paper needed 110  
    notice that different paper is  
    needed 110

## F

factory defaults, restoring  
    using Printer Settings 108  
    using the Embedded Web  
    Server 108  
    using the Local Printer Settings  
    Utility 108  
    using the printer control  
    panel 108  
FCC notices 141, 142  
finding information  
    customer support 8  
    publications 8  
Finishing menu 80  
    using 70  
Flushing buffer 93

## G

General settings menu 77  
guidelines  
    letterhead 60

## H

Hex Trace 93

## I

installing

printer software 19

installing software

Local Printer Settings Utility 69

Invalid Engine Code 93

Invalid Network Code 93

IPv6 menu 88

## J

jam

light sequences 114

messages 114

jam recovery

setting 65

jams

accessing jam areas 114

avoiding 113

jams, clearing

200 118, 120

201 118, 120

233 122

behind photoconductor kit and  
toner cartridge unit 118

behind the rear door 124

from manual feeder 123

from standard exit bin 120

from standard tray 120

from Tray 1 120

from Tray 2 122

## L

labels, paper

tips 62

letterhead

guidelines 60

loading, manual feeder 60

loading, trays 60

light sequences

on printer control panel 21, 28

primary 21

secondary error 28

secondary paper jam 34

linking trays 48

Load <src> with <x> 94

Load manual feeder with <x> 94

loading

envelopes 46

letterhead in manual feeder 60

letterhead in trays 60

manual feeder 46

optional 250-sheet tray 45

optional 550-sheet tray 45

standard 250-sheet tray 41

Local Printer Settings Utility

installing 69

using 69

## M

manual duplex printing 59

manual feeder

loading 46

memory card

installing 16

troubleshooting 130

menu settings

loading on multiple printers 111

menu settings page

printing 63

menus

AppleTalk 88

Custom Types 76

Default Source 71

diagram of 67

Finishing 80

General settings 77

in Local Printer Settings Utility 69

IPv6 88

Network 85

Network Card 86

Paper Loading 75

Paper Texture 74

Paper Weight 75

parallel 90

PCL Emul 83

PostScript 83

Quality 82

Setup 79

Size/Type 71

TCP/IP 87

Universal Setup 76

USB 89

menus, accessing

using the Embedded Web

Server 67

moving the printer 107

## N

Network Card menu 86

Network menu 85

network setup page

printing 63

noise emission levels 145

notices 141, 142, 143, 144, 145,

146, 147

N-up setting

Finishing menu 70

## O

optional trays, loading 45

options

250-sheet drawer 17

550-sheet drawer 17

memory card 16

ordering

toner cartridges 101

## P

paper

characteristics 51

letterhead 52

preprinted forms 52

recycled 53

selecting 52

setting size 40

setting type 40

storing 53

unacceptable 52

Universal Paper Size 76

Universal size setting 40

paper capacities

manual feeder 47

trays 47

paper feed troubleshooting

lights remain on after jam is

cleared 130

page that jammed does not

reprint 131

paper jam

light sequences 114

messages 114

paper jams

accessing jam areas 114

avoiding 113

light sequences 34

locating 114

paper jams, clearing

200 118, 120

- 201 118, 120
- 233 122
- behind photoconductor kit and toner cartridge unit 118
- behind the rear door 124
- from manual feeder 123
- from standard exit bin 120
- from standard tray 120
- from Tray 1 120
- from Tray 2 122
- Paper Loading menu 75
- paper sizes
  - supported by the printer 55
- paper stop, using 47
- Paper Texture menu 74
- paper types
  - duplex support 54
  - supported by printer 54
  - where to load 54
- Paper Weight menu 75
- Parallel menu 90
- parallel port 18
- PCL Emul menu 83
- photoconductor kit
  - ordering 102
  - replacing 104
- PostScript menu 83
- Power Saver 94
  - adjusting 108
- print job
  - canceling from Macintosh 65
  - canceling from the printer control panel 65
  - canceling from Windows 65
- print quality test pages
  - printing 64, 131
- print quality troubleshooting
  - blank pages 132
  - characters have jagged edges 132
  - clipped images 132
  - ghost images 133
  - gray background 133
  - poor transparency quality 137
  - print is too dark 134
  - print is too light 135
  - skewed print 136
  - solid black streaks 139
  - solid white streaks 139
  - streaked horizontal lines 137
  - streaked vertical lines 138
- toner fog or background shading 136
- toner rubs off 136
- toner specks 137
- print troubleshooting
  - incorrect characters print 128
  - incorrect margins 134
  - job prints from wrong tray 127
  - job prints on wrong paper 127
  - job takes longer than expected 127
  - jobs do not print 126
  - Large jobs do not collate 128
  - multiple-language PDFs do not print 127
  - paper curl 134
  - paper frequently jams 130
  - tray linking does not work 128
- printer
  - basic model 9
  - configurations 9
  - minimum clearances 14
  - moving 107
  - selecting a location 14
  - shipping 107
- printer control panel 21, 28, 34
  - buttons 12
  - lights 12
- printer message
  - 201.yy Paper jam 97
- printer messages
  - 200.yy Paper jam 96
  - 202.yy Paper jam 97
  - 231.yy Paper jam 97
  - 233.yy Paper jam 97
  - 234.yy Paper jam 98
  - 235.yy Paper jam 98
  - 24x.yy Paper jam 98
  - 251.yy Paper jam 98
  - 31.yy Replace defective or missing cartridge 95
  - 32.yy Cartridge part number unsupported by device 95
  - 34 Short paper 95
  - 37 Insufficient memory to collate job 95
  - 38 Memory full 95
  - 39 Complex page, some data may not have printed 96
  - 42.xy Cartridge region mismatch 96
- 54 Standard network software error 96
- 84 PC Kit life warning 96
- 84 Replace PC Kit 96
- Busy 93
- Canceling 93
- Close front door 93
- Flushing buffer 93
- Hex Trace 93
- Invalid Engine Code 93
- Invalid Network Code 93
- Load <src> with <x> 94
- Load manual feeder with <x> 94
- Not Ready 94
- Power Saver 94
- Programming Engine Code 94
- Programming System Code 94
- Ready 94
- Remove paper from standard output bin 94
- Restoring Factory Defaults 94
- Waiting 95
- printer options troubleshooting
  - drawers 129
  - memory card 130
  - option not working 129
- printer problems, solving
  - basic 126
- printer settings configuration sheet
  - printing 38
- printer status
  - not ready 94
- printing
  - booklet 63
  - duplex (2-sided) 58, 59
  - duplex, manual 59
  - from Macintosh 57
  - from Windows 57
  - installing printer software 19
  - menu settings page 63
  - network setup page 63
  - on both sides of paper manually 59
  - on both sides of the paper 58, 59
  - print quality test pages 64, 131
  - Programming Engine Code 94
  - Programming System Code 94

## Q

Quality menu 82

## R

- Ready 94
- recycled paper
  - using 53
- recycling
  - Lexmark products 107
  - WEEE statement 145
- Remove paper from standard output bin 94
- replacing
  - photoconductor kit 104
  - toner cartridge 102
- reports
  - viewing 109
- reprint page
  - after paper jam 65
- Restoring Factory Defaults 94

## S

- safeguarding
  - menus 110
- safety information 7
- security
  - protecting menus 110
- separator sheet setting
  - Finishing menu 70
- setting
  - paper size 40
  - paper type 40
  - TCP/IP address 87
  - Universal Paper Size 40
- Setup menu 79
- shipping the printer 107
- Size/Type menu 71
- standard 250-sheet tray
  - loading 41
- standard exit bin, using 47
- status of supplies, checking 100
- storing
  - paper 53
  - supplies 99
- supplies
  - conserving 99
  - status of 100
  - storing 99
- supplies, ordering
  - photoconductor kit 102
  - toner cartridges 101
- supply notifications
  - configuring 111

- system board
  - accessing 15

## T

- TCP/IP menu 87
- tips
  - card stock 63
  - envelopes 61
  - labels, paper 62
  - transparencies 61
- toner cartridge
  - replacing 102
- toner cartridges
  - ordering 101
- transparencies
  - tips 61
- tray linking 49, 50
- tray unlinking 50
- trays
  - linking 48
  - unlinking 49
- troubleshooting
  - checking an unresponsive printer 126
  - contacting Customer Support 139
  - solving basic printer problems 126
- troubleshooting, paper feed
  - lights remain on after jam is cleared 130
  - page that jammed does not reprint 131
- troubleshooting, print
  - incorrect characters print 128
  - incorrect margins 134
  - job prints from wrong tray 127
  - job prints on wrong paper 127
  - job takes longer than expected 127
  - jobs do not print 126
  - Large jobs do not collate 128
  - multiple-language PDFs do not print 127
  - paper curl 134
  - paper frequently jams 130
  - tray linking does not work 128
- troubleshooting, print quality
  - blank pages 132
  - characters have jagged edges 132
  - clipped images 132

- ghost images 133
- gray background 133
- poor transparency quality 137
- print is too dark 134
- print is too light 135
- skewed print 136
- solid black streaks 139
- solid white streaks 139
- streaked horizontal lines 137
- streaked vertical lines 138
- toner fog or background shading 136
- toner rubs off 136
- toner specks 137
- troubleshooting, printer options
  - drawers 129
  - memory card 130
  - option not working 129

## U

- Universal Paper Size 76
  - setting 40
- Universal Setup menu 76
- unlinking trays 49
- USB menu 89
- USB port 18

## V

- viewing
  - reports 109
- virtual display
  - how to access 93

## W

- Waiting 95