

MUSIC PRODUCTION SYNTHESIZER

MOXF6**MOXF8**

Data List

Table of Contents

Voice List.....	2
Drum Voice List	12
Drum Voice Name List.....	12
Drum Kit Assign List	13
Waveform List	32
Performance List	45
Master Assign List	47
Arpeggio Type List	48
Effect Type List.....	97
Effect Parameter List.....	98
Effect Preset List	106
Effect Data Assign Table	108
Mixing Template List	116
Remote Control Assignments.....	117
Control List	118
MIDI Data Format.....	119
MIDI Data Table	123
MIDI Implementation Chart.....	146

Voice List

PRE1 (MSB=63, LSB=0)

Number		Voice Name	Category		Element
			Main	Sub	
1	A01	Full Concert Grand	Piano	APno	2
2	A02	Rock Grand Piano	Piano	Modrn	2
3	A03	Mellow Grand Piano	Piano	APno	2
4	A04	Glasgow	Piano	APno	4
5	A05	Romantic Piano	Piano	APno	2
6	A06	Aggressive Grand	Piano	Modrn	3
7	A07	Tacky	Piano	Modrn	2
8	A08	House Piano	Piano	Modrn	3
9	A09	Old and Squashed	Piano	Vintg	1
10	A10	Ballad Key	Piano	Layer	3
11	A11	80s Layer	Piano	Layer	4
12	A12	Ballad Stack	Piano	Layer	4
13	A13	Piano Back	Piano	Layer	4
14	A14	Piano & Strings	Piano	Layer	4
15	A15	Piano & Ooh Choir	Piano	Layer	4
16	A16	Monaural Grand MW	Piano	APno	1
17	B01	Old Blues	Piano	Vintg	2
18	B02	1968	Piano	Vintg	2
19	B03	CP 1979	Piano	Vintg	1
20	B04	CP70 Chorus	Piano	Vintg	1
21	B05	Journey	Piano	Vintg	1
22	B06	Vintage'74	Keys	EP	1
23	B07	R&B Soft	Keys	EP	1
24	B08	Early 70's	Keys	EP	2
25	B09	Soft Case	Keys	EP	1
26	B10	Crunchy Comp	Keys	EP	1
27	B11	Vintage Case	Keys	EP	1
28	B12	Hard Vintage	Keys	EP	1
29	B13	Sweetness MW+AS2	Keys	EP	1
30	B14	Phaser Vintage	Keys	EP	1
31	B15	Vintage Phase	Keys	EP	1
32	B16	Early Fusion	Keys	EP	2
33	C01	Neo Soul MW+AS1	Keys	EP	1
34	C02	1983 MW+AS1	Keys	EP	2
35	C03	Contempo	Keys	EP	1
36	C04	Clicky Dyno MW+AS2	Keys	EP	1
37	C05	Dyno Straight MW+AS2	Keys	EP	2
38	C06	Dyno Chorus MW+AS2	Keys	EP	1
39	C07	80s Boosted	Keys	EP	2
40	C08	Chorus Hard	Keys	EP	1
41	C09	Max Time	Keys	EP	3
42	C10	Bell Chorus	Keys	FM	2
43	C11	Drive EP AS1	Keys	EP	1
44	C12	Vinyl EP AS1	Keys	EP	2
45	C13	Natural Wurli	Keys	EP	2
46	C14	Wurli EP Bright	Keys	EP	1
47	C15	Wurli Distortion AS1	Keys	EP	2
48	C16	Phaze Wurli	Keys	EP	1
49	D01	DX Legend	Keys	FM	2
50	D02	Bell DX	Keys	FM	3
51	D03	DX Woody	Keys	FM	2
52	D04	Full Tine	Keys	FM	2
53	D05	DX Mellow	Keys	FM	2
54	D06	DX Crisp	Keys	FM	2
55	D07	DX Celesta EP	Keys	FM	2
56	D08	DX Pluck EP	Keys	FM	2
57	D09	DX-7 II AS1	Keys	FM	3
58	D10	GS Tines AF1&2	Keys	FM	2
59	D11	Galaxy DX	Keys	FM	4
60	D12	TX816 Bell Piano	Keys	FM	4
61	D13	Marimba DX	Keys	FM	4
62	D14	DX5-Zero	Keys	FM	4
63	D15	Hybrid EP	Keys	EP	3
64	D16	Mixed Up	Keys	EP	3

Number		Voice Name	Category		Element
			Main	Sub	
65	E01	Dyno Wurli	Keys	EP	2
66	E02	Analog Piano	Keys	Synth	2
67	E03	AhrAml	Keys	Synth	2
68	E04	Electro Piano	Keys	EP	2
69	E05	Transistor Piano	Keys	Synth	2
70	E06	EP Pad	Keys	EP	3
71	E07	DX Pad	Keys	EP	4
72	E08	Dyno Choir	Keys	EP	3
73	E09	Vintage Clavi	Keys	Clavi	2
74	E10	Super Clavi	Keys	Clavi	1
75	E11	Stereo Clavi	Keys	Clavi	2
76	E12	Hollow Clavi	Keys	Clavi	1
77	E13	Nu Phasing	Keys	Clavi	2
78	E14	Touch Clavi	Keys	Clavi	3
79	E15	Pedal Wah Clavi MW	Keys	Clavi	3
80	E16	Pulse Clavi	Keys	Clavi	1
81	F01	Guitarsichord	Keys	Clavi	3
82	F02	Hipsichord	Keys	Clavi	3
83	F03	16 + 8 + 5&1/3	Organ	TnWhl	4
84	F04	Jazz 2nd Perc + C3	Organ	TnWhl	5
85	F05	First 3 w/Perc	Organ	TnWhl	4
86	F06	Slow Jam	Organ	TnWhl	3
87	F07	Cool Cat	Organ	TnWhl	4
88	F08	Jazzy 1	Organ	TnWhl	4
89	F09	Jazzy 2	Organ	TnWhl	4
90	F10	Jazzy Chorus	Organ	TnWhl	4
91	F11	On Road AS1	Organ	TnWhl	4
92	F12	Progressy	Organ	TnWhl	4
93	F13	Rocky AS2	Organ	TnWhl	4
94	F14	Crunchy AS2	Organ	TnWhl	4
95	F15	1972 AS1	Organ	Combo	8
96	F16	Glassy AF1	Organ	TnWhl	4
97	G01	Clean	Organ	TnWhl	2
98	G02	All Bars Perc AF1&2	Organ	TnWhl	8
99	G03	Rotor Vibrato	Organ	TnWhl	8
100	G04	Vib Chorus AF1	Organ	TnWhl	1
101	G05	Soulemn	Organ	TnWhl	3
102	G06	Mellow AS2	Organ	TnWhl	2
103	G07	Fully	Organ	TnWhl	4
104	G08	FullDraw/CVibrato	Organ	TnWhl	2
105	G09	Even Out	Organ	TnWhl	4
106	G10	Harmonic Hole	Organ	TnWhl	5
107	G11	A Few Wheels	Organ	TnWhl	4
108	G12	Left Manual	Organ	TnWhl	4
109	G13	Draw Control	Organ	TnWhl	4
110	G14	Stop Rotar	Organ	TnWhl	5
111	G15	Clean Noise	Organ	TnWhl	3
112	G16	Walking Bass	Organ	TnWhl	3
113	H01	Greasy	Organ	TnWhl	4
114	H02	Swishie	Organ	TnWhl	3
115	H03	Solo Percussion AF2	Organ	TnWhl	2
116	H04	PercussionVibratoAF2	Organ	TnWhl	2
117	H05	Tiny Combo Bars 1	Organ	Combo	4
118	H06	Tiny Combo Bars 2	Organ	Combo	3
119	H07	Panther	Organ	Combo	3
120	H08	1967 Keys	Organ	Combo	1
121	H09	YD-45C	Organ	Combo	3
122	H10	Diamond Head	Organ	Synth	2
123	H11	Early Bird	Organ	TnWhl	4
124	H12	Moet	Organ	Synth	2
125	H13	Bollinger	Organ	Synth	2
126	H14	Vinyl Organ	Organ	Synth	2
127	H15	Alternator	Organ	TnWhl	3
128	H16	Flying Rhythm Bars	Organ	Synth	6

PRE2 (MSB=63, LSB=1)

Number		Voice Name	Category		Element
			Main	Sub	
1	A01	Roundabout	Organ	Arp	1
2	A02	Tradi	Organ	TnWhl	4
3	A03	Petit	Organ	TnWhl	1
4	A04	Fluty	Organ	TnWhl	1
5	A05	Fluty Pipe	Organ	Pipe	3
6	A06	St. Peter	Organ	Pipe	1
7	A07	St. Paul AF1&2	Organ	Pipe	3
8	A08	Impromptu	Organ	Pipe	4
9	A09	Mixture	Organ	Pipe	3
10	A10	Reed Split	Organ	Pipe	4
11	A11	Medieval MW	Organ	Pipe	4
12	A12	Breath Pipe	Organ	Pipe	4
13	A13	Reedy Pipe	Organ	Pipe	4
14	A14	Sunday	Organ	Pipe	4
15	A15	Accordions AF1&2	Organ	Pipe	1
16	A16	Soft Marimba	CPerc	Malet	1
17	B01	Vibes Bow MW	CPerc	Malet	3
18	B02	Twinkle	CPerc	Bell	4
19	B03	Stick Bell	CPerc	Bell	3
20	B04	Ice Bells	CPerc	Bell	4
21	B05	Bell Ice	CPerc	Bell	3
22	B06	Stack Bell	CPerc	SynBl	4
23	B07	J-Pop	CPerc	Bell	3
24	B08	Chorus Bell	CPerc	Bell	2
25	B09	Handbell	CPerc	Bell	2
26	B10	Bell Chiff	CPerc	SynBl	2
27	B11	Sako Bell	CPerc	SynBl	2
28	B12	Nice Bell	CPerc	SynBl	4
29	B13	Noisy Bell	CPerc	SynBl	3
30	B14	Pop Bells & Pad MW	CPerc	Bell	4
31	B15	Going To Heaven	CPerc	Arp	3
32	B16	Digibox	CPerc	SynBl	3
33	C01	Nibelungen	CPerc	Bell	2
34	C02	Wood Bell	CPerc	Bell	4
35	C03	Marimbell	CPerc	SynBl	4
36	C04	Synth Steel Drum	CPerc	PDrum	3
37	C05	Gamelan	CPerc	Bell	2
38	C06	Ethnic Dream	CPerc	Malet	2
39	C07	Mystic Bowl	CPerc	Bell	2
40	C08	Mbira	Ethnic	Pluk	4
41	C09	Glass Mbira	CPerc	PDrum	4
42	C10	Island Bell	CPerc	SynBl	3
43	C11	Tibetan	CPerc	Bell	3
44	C12	Rimba Bells	CPerc	SynBl	3
45	C13	Lost in Asia	CPerc	Bell	4
46	C14	Coconuts Random	CPerc	Arp	1
47	C15	Kodo	CPerc	PDrum	1
48	C16	Timpani/Bell/Glocken	CPerc	Bell	2
49	D01	Orc Percussion	CPerc	Bell	4
50	D02	Classical AF1&2	Guitar	A.Gtr	2
51	D03	High Tension AF1&2	Guitar	A.Gtr	2
52	D04	Sao Paulo	Guitar	A.Gtr	2
53	D05	Barcelona	Guitar	A.Gtr	4
54	D06	Nylon Slide Vel	Guitar	A.Gtr	4
55	D07	Nylon Harmonics Vel	Guitar	A.Gtr	4
56	D08	Classical 12 Strings	Guitar	A.Gtr	4
57	D09	Hip-Hop Nylon Guitar	Guitar	A.Gtr	2
58	D10	Steel String AF1&2	Guitar	A.Gtr	2
59	D11	Old Strings AF1&2	Guitar	A.Gtr	2
60	D12	Steel Slide Vel	Guitar	A.Gtr	4
61	D13	Mute & Slide Vel	Guitar	A.Gtr	2
62	D14	Steel Harmonics Vel	Guitar	A.Gtr	4
63	D15	Hip-Hop Steel Guitar	Guitar	A.Gtr	2
64	D16	Hi Strings	Guitar	A.Gtr	2

Number		Voice Name	Category		Element
			Main	Sub	
65	E01	Two Acoustics	Guitar	A.Gtr	4
66	E02	2 Steel Strings	Guitar	A.Gtr	4
67	E03	Big 12 Strings	Guitar	A.Gtr	4
68	E04	Airy 12 AF1&2	Guitar	A.Gtr	4
69	E05	Wide 12 strings AF1	Guitar	A.Gtr	4
70	E06	12Strings Mono	Guitar	A.Gtr	2
71	E07	Clean EI & Ac 1	Guitar	E.Cln	3
72	E08	Clean EI & Ac 2	Guitar	E.Cln	3
73	E09	Clean EI & Ac 3	Guitar	E.Cln	3
74	E10	Strange 12	Guitar	E.Cln	4
75	E11	Jazzy Pick	Guitar	E.Cln	2
76	E12	Melodic Jazz	Guitar	E.Cln	2
77	E13	Fat Oil Jazz AF1&2	Guitar	E.Cln	1
78	E14	Touch Wah AF1	Guitar	E.Cln	1
79	E15	Baby AF1	Guitar	E.Cln	3
80	E16	Good Night	Guitar	E.Cln	1
81	F01	Dynamic Clean AF1&2	Guitar	E.Cln	1
82	F02	Single Coil Chorus	Guitar	E.Cln	2
83	F03	Distant	Guitar	E.Cln	4
84	F04	Some Hair	Guitar	E.Dst	3
85	F05	Clean Slide Vel	Guitar	E.Cln	2
86	F06	Hit It Hard AS2	Guitar	E.Cln	2
87	F07	Paddy Clean	Guitar	E.Cln	2
88	F08	Bluesy Clean Legato	Guitar	E.Cln	2
89	F09	Dual Coil '65	Guitar	E.Dst	2
90	F10	Dual Coil Amp AS1	Guitar	E.Cln	1
91	F11	Roto Guitar MW	Guitar	E.Cln	2
92	F12	Dual Coil Slide Vel	Guitar	E.Cln	2
93	F13	Dual Coil Slap Vel	Guitar	E.Cln	2
94	F14	Dual Coil 80s Clean	Guitar	E.Cln	2
95	F15	Dual Coil Rotary	Guitar	E.Cln	2
96	F16	Electric 12Strings	Guitar	E.Cln	3
97	G01	Rotator AF1&2	Guitar	E.Dst	2
98	G02	Middy Tremolo	Guitar	E.Dst	3
99	G03	Retro Flanger	Guitar	E.Cln	2
100	G04	Vintage Strum	Guitar	E.Cln	3
101	G05	Spanky	Guitar	E.Dst	2
102	G06	Rockabilly	Guitar	E.Dst	2
103	G07	2 Electrics AF1&2	Guitar	E.Cln	2
104	G08	Light Blues AF1&2	Guitar	E.Dst	1
105	G09	Dual Coil Semi Clean	Guitar	E.Cln	1
106	G10	Chorus Dist AF1&2	Guitar	E.Dst	2
107	G11	Tex Boogie	Guitar	E.Dst	3
108	G12	59 Combo AF1&2	Guitar	E.Dst	2
109	G13	Alternative Rocker	Guitar	E.Dst	2
110	G14	Overdrive Mute&Harmo	Guitar	E.Dst	1
111	G15	Crunched Up 376	Guitar	E.Dst	3
112	G16	Dynamic Amp AS1	Guitar	E.Dst	3
113	H01	Chuggin' Guitar	Guitar	E.Dst	2
114	H02	Chugga	Guitar	E.Dst	1
115	H03	Small Amp AS1	Guitar	E.Dst	2
116	H04	Metal Mute AS2	Guitar	E.Dst	2
117	H05	DistortionMute&Harmo	Guitar	E.Dst	1
118	H06	Cool Drive AS1	Guitar	E.Dst	3
119	H07	Hard Drive AS1&2	Guitar	E.Dst	4
120	H08	Hard Ramp AS1&2	Guitar	E.Dst	3
121	H09	Heavy Drive	Guitar	E.Dst	2
122	H10	No.1 GTR AS1&2	Guitar	E.Dst	2
123	H11	Snake Finger	Guitar	E.Dst	2
124	H12	Dual Coil Blue Lead	Guitar	E.Dst	2
125	H13	Over The Top	Guitar	E.Dst	2
126	H14	Woodooman	Guitar	E.Dst	2
127	H15	Killer Whammy	Guitar	E.Dst	3
128	H16	Latin Lover	Guitar	E.Dst	1

PRE3 (MSB=63, LSB=2)

Number	Voice Name	Category		Element	
		Main	Sub		
1	A01	Oct FuzzPedalWah MW	Guitar	E.Dst	3
2	A02	DualCoilLeadWah MW	Guitar	E.Dst	2
3	A03	DualCoilHarmonicsVel	Guitar	E.Dst	3
4	A04	Crunchy Guitar	Guitar	E.Dst	3
5	A05	Beater AS2	Guitar	E.Dst	2
6	A06	HIP Mute	Guitar	E.Cln	2
7	A07	Pedal Steel	Guitar	E.Cln	2
8	A08	DualCoil80sCleanMute	Guitar	E.Cln	1
9	A09	Mid Drive (2handGtr)	Guitar	E.Dst	3
10	A10	HardRocker(2handGtr)	Guitar	E.Dst	3
11	A11	ToughTube (2handGtr)	Guitar	E.Dst	1
12	A12	DriveWah (2handGtr)	Guitar	E.Dst	4
13	A13	Resonator Guitar	Guitar	A.Gtr	4
14	A14	Velo Growl	Bass	ABass	2
15	A15	GrooveAcoustic AF1&2	Bass	ABass	1
16	A16	Upright	Bass	ABass	2
17	B01	Prec Flat Wound	Bass	EBass	2
18	B02	Round Wound	Bass	EBass	2
19	B03	Active P	Bass	EBass	2
20	B04	Mid Range Finger	Bass	EBass	2
21	B05	Active TRB	Bass	EBass	1
22	B06	Passive BB AF1&2	Bass	EBass	1
23	B07	Vintage JB AF1&2	Bass	EBass	1
24	B08	StraightFinger AF1&2	Bass	EBass	1
25	B09	JB Flat Wound AF1&2	Bass	EBass	1
26	B10	Finger PBs AF1	Bass	EBass	1
27	B11	Prec Amped AF1	Bass	EBass	2
28	B12	Finger Bass Amp AF1	Bass	EBass	2
29	B13	Fret Buzzy	Bass	EBass	2
30	B14	Small Cabinet	Bass	EBass	1
31	B15	Simple Pick	Bass	EBass	1
32	B16	Pick Open	Bass	EBass	3
33	C01	Pick Mute	Bass	EBass	2
34	C02	Pick Pull	Bass	EBass	2
35	C03	Straight Pick AF1&2	Bass	EBass	2
36	C04	Velo Bass	Bass	EBass	1
37	C05	Slap Switch	Bass	EBass	2
38	C06	Fretless Dry	Bass	EBass	2
39	C07	Fretless Solo	Bass	EBass	2
40	C08	PBassFingerDist AF1	Bass	EBass	2
41	C09	Fuzz Bass AF1AS1	Bass	EBass	3
42	C10	Gnarly Bass	Bass	EBass	1
43	C11	BaCement	Bass	EBass	1
44	C12	Dist Tama Bass	Bass	EBass	3
45	C13	5th Fuzz Bass	Bass	EBass	3
46	C14	Chili Bass	Bass	EBass	3
47	C15	Big Cabinet	Bass	EBass	2
48	C16	Hybrid Bass 1	Bass	EBass	3
49	D01	Hybrid Bass 2	Bass	EBass	3
50	D02	3 VCOs	Bass	SynBs	4
51	D03	Brain Bass AF1&2	Bass	SynBs	3
52	D04	Lo Boy AF1&2 AS1&2	Bass	SynBs	3
53	D05	Dark Bass	Bass	SynBs	1
54	D06	RnBass	Bass	SynBs	2
55	D07	Fundamental	Bass	SynBs	2
56	D08	Fat Sine Resonance	Bass	SynBs	3
57	D09	Moon Bass	Bass	SynBs	1
58	D10	More Fatty	Bass	SynBs	4
59	D11	Chill Out Bass AF1	Bass	SynBs	1
60	D12	Growler	Bass	SynBs	2
61	D13	Smacked	Bass	SynBs	2
62	D14	boooooooooooooom	Bass	SynBs	2
63	D15	Biting	Bass	SynBs	2
64	D16	Boogie A LegatoAF1	Bass	SynBs	3

Number	Voice Name	Category		Element	
		Main	Sub		
65	E01	Uni Punch	Bass	SynBs	2
66	E02	Noise Bass	Bass	SynBs	1
67	E03	Single Oscillator	Bass	SynBs	1
68	E04	Unison	Bass	SynBs	3
69	E05	Long Spit AF2	Bass	SynBs	2
70	E06	Big Bass	Bass	SynBs	3
71	E07	Bass&Comp!	Bass	SynBs	4
72	E08	Rave Blade	Bass	SynBs	2
73	E09	Plastic Bass	Bass	SynBs	3
74	E10	Funky Resonance	Bass	SynBs	3
75	E11	Phat Three	Bass	SynBs	3
76	E12	Needle Bass	Bass	SynBs	3
77	E13	Acidd	Bass	SynBs	3
78	E14	Boom Bass AF1	Bass	SynBs	2
79	E15	'West Coast	Bass	SynBs	2
80	E16	Wazzo	Bass	SynBs	2
81	F01	Fast PWM Bass	Bass	SynBs	2
82	F02	Bass Pedal	Bass	SynBs	2
83	F03	Oxide	Bass	SynBs	2
84	F04	Bowngo	Bass	SynBs	1
85	F05	'Wide Synth Bass	Bass	SynBs	2
86	F06	Dry Synth Bass	Bass	SynBs	1
87	F07	Kick Bass Legato	Bass	SynBs	3
88	F08	Keep Dancin' AS2	Bass	SynBs	3
89	F09	'Velo Master	Bass	SynBs	1
90	F10	'Wah Bass	Bass	SynBs	2
91	F11	Pulse Step AF1	Bass	SynBs	2
92	F12	Phat Step AS1&2	Bass	SynBs	2
93	F13	Octave Analog	Bass	SynBs	2
94	F14	Sync Bass	Bass	SynBs	1
95	F15	Sync Big	Bass	SynBs	2
96	F16	Puncher AS1	Bass	SynBs	2
97	G01	Dark Comp AF1&2	Bass	SynBs	2
98	G02	Simple Bass AS2	Bass	SynBs	2
99	G03	Fat Sine	Bass	SynBs	4
100	G04	Kompressor	Bass	SynBs	3
101	G05	Dark Uni	Bass	SynBs	1
102	G06	Fight Bass	Bass	SynBs	3
103	G07	Byon Bass	Bass	SynBs	5
104	G08	One Voice	Bass	SynBs	1
105	G09	Pro-Attack AF1	Bass	SynBs	2
106	G10	Bobby Bass	Bass	SynBs	2
107	G11	Trance Bass AS2	Bass	SynBs	2
108	G12	Short Sequence Bass	Bass	SynBs	2
109	G13	Lately	Bass	SynBs	2
110	G14	Faaat Pulse	Bass	SynBs	3
111	G15	Short PWM Bass	Bass	SynBs	2
112	G16	Hyper Velocity AF1	Bass	SynBs	2
113	H01	Deep Point	Bass	SynBs	2
114	H02	Pulse Stop	Bass	SynBs	1
115	H03	Oh Bee Bass	Bass	SynBs	2
116	H04	Booming Bass	Bass	SynBs	3
117	H05	Army Bass	Bass	SynBs	2
118	H06	Punchy Drone	Bass	SynBs	4
119	H07	Dee Tune	Bass	SynBs	2
120	H08	Chorus Pulse	Bass	SynBs	1
121	H09	Sweeper	Bass	SynBs	2
122	H10	Old House Organ	Bass	SynBs	4
123	H11	Data Run	Bass	Arp	1
124	H12	Sharp 3o3	Bass	Arp	1
125	H13	Short 3o3 Saw	Bass	Arp	1
126	H14	Acid Fun AS1	SynLd	Arp	1
127	H15	Compu Bass	Bass	Arp	1
128	H16	Squeaker Bass	Bass	Arp	1

PRE4 (MSB=63, LSB=3)

Number	Voice Name	Category		Element	
		Main	Sub		
1	A01	Violin Solo 1	String	Solo	3
2	A02	Violin Solo 2 AF1	String	Solo	1
3	A03	Viola Solo 1	String	Solo	3
4	A04	Viola Solo 2 AF1	String	Solo	2
5	A05	Cello Solo	String	Solo	3
6	A06	Cello Duo AF1	String	Solo	2
7	A07	Contrabass Solo	String	Solo	3
8	A08	Contrabass Solo2 AF1	String	Solo	2
9	A09	Quartet	String	Ensem	4
10	A10	Small Section	String	Ensem	3
11	A11	Small Ensemble	String	Ensem	4
12	A12	Almighty	String	Ensem	4
13	A13	Medium Section	String	Ensem	4
14	A14	Medium Hall	String	Ensem	4
15	A15	Medium Large Section	String	Ensem	2
16	A16	Quick Bows	String	Ensem	4
17	B01	Aggressive AF1	String	Ensem	2
18	B02	Large Section	String	Ensem	4
19	B03	Octave Ensemble	String	Ensem	4
20	B04	Full Chamber	String	Ensem	4
21	B05	Stryngs	String	Ensem	4
22	B06	Dynamik Bow	String	Ensem	4
23	B07	Symphonic Pizzicato	String	Pizz	2
24	B08	Plucky Pizzicato	String	Pizz	2
25	B09	Octave Pizzes	String	Pizz	4
26	B10	Tremolo Strings 1	String	Ensem	4
27	B11	TremoloStrings Small	String	Ensem	4
28	B12	Spicato Large	String	Pizz	4
29	B13	Disco AF1	String	Pizz	4
30	B14	Ens Mix	String	Ensem	2
31	B15	Lush	String	Ensem	4
32	B16	Back Ground	String	Ensem	4
33	C01	Romantic	String	Ensem	4
34	C02	Warm Back	String	Ensem	3
35	C03	Stringy	String	Ensem	4
36	C04	Big Strings	String	Ensem	4
37	C05	PWM Strings	String	Synth	3
38	C06	Mourn Strings	String	Synth	4
39	C07	VP Soft	String	Synth	3
40	C08	PWM Simple	String	Synth	3
41	C09	Glassy Rezonant	String	Synth	4
42	C10	Superstrings	String	Synth	3
43	C11	Light Pad	String	Synth	4
44	C12	Noble Pad	String	Synth	2
45	C13	Warm Big	String	Ensem	4
46	C14	Sentimental	String	Synth	4
47	C15	Analog Sweep	String	Synth	4
48	C16	Phase Strings AS1	String	Synth	4
49	D01	Octave Strings	String	Synth	4
50	D02	JP Strings	String	Synth	2
51	D03	3Oscillators Vintage	String	Synth	3
52	D04	Silver Strings	String	Synth	2
53	D05	String Machine	String	Synth	3
54	D06	3 Octave Strings	String	Synth	4
55	D07	Trance Introduction	String	Synth	2
56	D08	Mystic Trance	String	Synth	4
57	D09	F.Horn + Strings	String	Ensem	4
58	D10	Wood Winds + Strings	String	Synth	4
59	D11	ElectricViolin AF1&2	String	Solo	1
60	D12	Tron Violin	String	Synth	4
61	D13	Tron Strings	String	Synth	3
62	D14	Tape Strings AS2	String	Synth	3
63	D15	Orchestronic	String	Synth	4
64	D16	Vinyltron	String	Synth	4

Number	Voice Name	Category		Element	
		Main	Sub		
65	E01	Analog Strings	String	Synth	1
66	E02	Analog Ensemble	String	Ensem	3
67	E03	Pizz-o-matic	String	Arp	2
68	E04	Ambient Pizza	String	Arp	4
69	E05	Beauty Harp	String	Pizz	1
70	E06	Stereo Harp	String	Pizz	3
71	E07	Trumpet 1 AF1	Brass	Solo	2
72	E08	Tp Romantic Legato	Brass	Solo	2
73	E09	Classical Trumpet	Brass	Solo	1
74	E10	Baby Trumpet AF1	Brass	Solo	2
75	E11	Bright Trumpet AF1	Brass	Solo	2
76	E12	Tp Soft Jazz Legato	Brass	Solo	2
77	E13	Legend Mute AF1	Brass	Solo	3
78	E14	Jazzy Flugel AF1	Brass	Solo	2
79	E15	Trumpet Section	Brass	BrsEn	4
80	E16	Trombone 1 AF1	Brass	Solo	2
81	F01	Blown Bone Legato	Brass	Solo	1
82	F02	Bright Trombone AF1	Brass	Solo	2
83	F03	New Orleans Trombone	Brass	Solo	2
84	F04	French Horn AF1	Brass	Solo	1
85	F05	French Horn Solo	Brass	Solo	1
86	F06	BassTuba(Bb)	Brass	Solo	2
87	F07	Euphonium	Brass	Orche	2
88	F08	Bony Section	Brass	BrsEn	4
89	F09	French Horn Section	Brass	Orche	2
90	F10	F.Horn + Trombone	Brass	Orche	4
91	F11	F.Hrn + Trmbn + Trp	Brass	Orche	4
92	F12	Orchestra Brass	Brass	Orche	4
93	F13	Movie Horns	Brass	Orche	4
94	F14	Symphonic	Brass	Orche	4
95	F15	Smooth Brass	Brass	Orche	4
96	F16	SoftBrss mp-mf AF1&2	Brass	Orche	2
97	G01	Dynamic Brass AF1&2	Brass	Orche	2
98	G02	Accent mf-fall AF1&2	Brass	BrsEn	4
99	G03	Small Brass Section	Brass	BrsEn	2
100	G04	Medium Brass Section	Brass	BrsEn	4
101	G05	Lots O' Brass	Brass	BrsEn	4
102	G06	Bright Section	Brass	BrsEn	4
103	G07	Power Section	Brass	BrsEn	4
104	G08	Shiny Brass	Brass	BrsEn	4
105	G09	Big Brass AF1&2	Brass	BrsEn	4
106	G10	Sforzando AF1&2	Brass	BrsEn	4
107	G11	Soft Brass & Sax	Brass	BrsEn	4
108	G12	Big Band	Brass	BrsEn	4
109	G13	Sax Big Band	Brass	BrsEn	4
110	G14	Velo Falls	Brass	BrsEn	3
111	G15	Hybrid Section	Brass	Synth	3
112	G16	Hybrid Bright	Brass	Synth	3
113	H01	Hybrid Brass Swell	Brass	Synth	4
114	H02	T Brass	Brass	Synth	2
115	H03	Lo-fi AS1&2	Brass	BrsEn	1
116	H04	Quiet Brass	Brass	Synth	2
117	H05	Big Syn	Brass	Synth	2
118	H06	Thin	Brass	Synth	2
119	H07	XP Brass Stereo	Brass	Synth	2
120	H08	Simple Saw Brass	Brass	Synth	4
121	H09	Brassy	Brass	Synth	2
122	H10	Kustom	Brass	Synth	3
123	H11	After 1984	Brass	Synth	4
124	H12	Finale	Brass	Synth	2
125	H13	Huge CS80	Brass	Synth	2
126	H14	CS-90	Brass	Synth	2
127	H15	Ob Soft	Brass	Synth	4
128	H16	Ob Horns	Brass	Synth	2

PRE5 (MSB=63, LSB=4)

Number		Voice Name	Category		Element
			Main	Sub	
1	A01	Slow PWM Brass	Brass	Synth	2
2	A02	Soft 5th Brass	Brass	Synth	4
3	A03	Soprano Legato	SaxWW	Sax	2
4	A04	Soprano Soft AF1	SaxWW	Sax	2
5	A05	Alto Vib Legato	SaxWW	Sax	3
6	A06	Alto Legato	SaxWW	Sax	1
7	A07	Alto	SaxWW	Sax	1
8	A08	Tenor Dynamic AF1	SaxWW	Sax	3
9	A09	Tenor Soft Legato	SaxWW	Sax	3
10	A10	Velo Growl Legato	SaxWW	Sax	3
11	A11	Tenor Growl AF1	SaxWW	Sax	1
12	A12	Baritone	SaxWW	Sax	1
13	A13	Hip Bari	SaxWW	Sax	1
14	A14	Tenor Section	SaxWW	Sax	3
15	A15	Sax Octave Section	SaxWW	Sax	4
16	A16	Mixed Sax Section	SaxWW	Sax	4
17	B01	Flute Legato	SaxWW	Flute	3
18	B02	Sweet Flute AF1	SaxWW	Flute	2
19	B03	Wood Flute	SaxWW	Flute	2
20	B04	Oboe 1 AF1	SaxWW	RPipe	3
21	B05	Sweet Oboe Legato	SaxWW	RPipe	2
22	B06	Oboe Soft Legato	SaxWW	RPipe	2
23	B07	Clarinet 1 AF1	SaxWW	WWind	3
24	B08	JazzyClarinet Legato	SaxWW	RPipe	2
25	B09	Bassoon 1 AF1	SaxWW	RPipe	3
26	B10	Irish Pipe Legato	SaxWW	RPipe	1
27	B11	2 Flutes	SaxWW	Flute	3
28	B12	Flute & Clari	SaxWW	Flute	4
29	B13	2 Oboes & Bassoon	SaxWW	WWind	4
30	B14	WoodWind Quartet	SaxWW	WWind	8
31	B15	Gentle Harp	SaxWW	RPipe	1
32	B16	Woody Harp	SaxWW	RPipe	1
33	C01	Bluz Distort	SaxWW	RPipe	2
34	C02	Campfire	SaxWW	RPipe	2
35	C03	Tron Flute	SaxWW	Flute	3
36	C04	Flootz	SaxWW	Flute	2
37	C05	Huge Lead	SynLd	Analg	4
38	C06	Bleep Lead AF2	SynLd	Analg	2
39	C07	Detuned Vintage	SynLd	Analg	2
40	C08	Space Lead	SynLd	Analg	2
41	C09	Dual Square Lead	SynLd	Analg	2
42	C10	Vintage Sync	SynLd	Analg	2
43	C11	Dirty Hook	SynLd	Analg	4
44	C12	Nu Mini	SynLd	Analg	3
45	C13	ProgressiveRock Lead	SynLd	Analg	3
46	C14	Lucky	SynLd	Analg	2
47	C15	Opening	SynLd	Analg	2
48	C16	Rap Lead 1	SynLd	Analg	1
49	D01	Mini Soft	SynLd	Analg	2
50	D02	Feeling	SynLd	Analg	1
51	D03	Early Lead	SynLd	Analg	2
52	D04	Funky Pulse	SynLd	Digitl	1
53	D05	Mr. Finger	SynLd	Analg	2
54	D06	Singleline	SynLd	Analg	2
55	D07	Soft RnB	SynLd	Analg	1
56	D08	Wind Synth	SynLd	Analg	3
57	D09	Broken Sine AS1AS2	SynLd	Analg	1
58	D10	Duck Lead	SynLd	Analg	1
59	D11	In da Night	SynLd	Analg	1
60	D12	Mayday MW	SynLd	Analg	1
61	D13	On D Line	SynLd	Analg	2
62	D14	Early Soloist	SynLd	Analg	1
63	D15	Heterodyne	SynLd	Analg	1
64	D16	Classic 5th	SynLd	Analg	3

Number		Voice Name	Category		Element
			Main	Sub	
65	E01	Vintage Saw	SynLd	Analg	3
66	E02	Mini Three	SynLd	Digitl	3
67	E03	Phat Dino	SynLd	Digitl	3
68	E04	Dynamic Mini	SynLd	Digitl	3
69	E05	PWM Lead	SynLd	Digitl	2
70	E06	Pulse Wound	SynLd	Digitl	1
71	E07	Think Sync	SynLd	Digitl	3
72	E08	Punch Lead	SynLd	Digitl	2
73	E09	Bright Saw	SynLd	Digitl	2
74	E10	Trojan	SynLd	Digitl	3
75	E11	Wood Panel	SynLd	Digitl	2
76	E12	Push Ahead	SynLd	Digitl	1
77	E13	Eight	SynLd	Digitl	4
78	E14	Sync Power	SynLd	Digitl	2
79	E15	Gliten Lead	SynLd	Digitl	4
80	E16	Big Drone	SynLd	Digitl	4
81	F01	Screameemy	SynLd	Digitl	2
82	F02	Flange Filter	SynLd	Digitl	2
83	F03	Sutra	SynLd	Digitl	3
84	F04	Free LFO	SynLd	Digitl	1
85	F05	Rap Lead 2	SynLd	Digitl	1
86	F06	Space Power Lead	SynLd	Digitl	2
87	F07	Nyquist	SynLd	Digitl	2
88	F08	Digimetal	SynLd	Digitl	1
89	F09	Saw destroy	SynLd	Digitl	3
90	F10	Vinalog saw	SynLd	Digitl	4
91	F11	Mady SQU	SynLd	Digitl	2
92	F12	Low Undulation	SynLd	Digitl	4
93	F13	Impact	SynLd	H Hop	3
94	F14	Talk Mod	SynLd	H Hop	2
95	F15	Digital Gangsta	SynLd	H Hop	1
96	F16	Plastic Squeeze	SynLd	H Hop	1
97	G01	Pinz Lead	SynLd	H Hop	1
98	G02	Dancy Saw Lead	SynLd	Dance	2
99	G03	Buzz Around	SynLd	Dance	3
100	G04	Xtreme Wheel	SynLd	Dance	2
101	G05	Supertrance	SynLd	Dance	4
102	G06	Poly Hook	SynLd	Dance	2
103	G07	HPF Dance	SynLd	Dance	2
104	G08	Tekk Glide	SynLd	Dance	2
105	G09	Growl Tekk	SynLd	Dance	1
106	G10	Plucked Chordz	SynLd	Dance	4
107	G11	Chordz	SynLd	Dance	4
108	G12	Cool Body	SynLd	Dance	4
109	G13	Twist Sync	SynLd	Dance	2
110	G14	TEKIE	SynLd	Dance	4
111	G15	Sonix	SynLd	Dance	3
112	G16	Big Skid Hook Lead 1	SynLd	Dance	4
113	H01	Big Skid Hook Lead 2	SynLd	Dance	4
114	H02	Porta Queen	SynLd	Arp	2
115	H03	Vicious Dogs	SynLd	Arp	4
116	H04	Saw Pad	Pads	Analg	4
117	H05	Dark Modulation Pad	Pads	Analg	2
118	H06	Dark Light	Pads	Warm	2
119	H07	Ambient Synthpad	Pads	Analg	2
120	H08	5th Lite	Pads	Analg	4
121	H09	Smooth BPF Sweep	Pads	Analg	2
122	H10	High Wire	Pads	Analg	2
123	H11	Trance MW	Pads	Analg	2
124	H12	Xtreme Sweep	Pads	Analg	2
125	H13	Nu WarmPad	Pads	Warm	2
126	H14	5th Atmosphere	Pads	Warm	4
127	H15	Dim	Pads	Warm	1
128	H16	Simple Air	Pads	Warm	2

PRE6 (MSB=63, LSB=5)

Number		Voice Name	Category		Element
			Main	Sub	
1	A01	Nature Sine	Pads	Warm	3
2	A02	Analog	Pads	Warm	2
3	A03	Perc Pad	Pads	Warm	4
4	A04	Dark Atmo Pad	Pads	Warm	4
5	A05	Dark Organ Pad	Pads	Warm	2
6	A06	Soft Brassy	Pads	Warm	2
7	A07	Road to Nowhere	Pads	Warm	4
8	A08	Sweep Strings	Pads	Warm	3
9	A09	Brass Motion Pad	Pads	Warm	2
10	A10	Luminous	Pads	Warm	4
11	A11	Mother Ship	Pads	Choir	4
12	A12	Warm Backing Pad	Pads	Warm	2
13	A13	Feather	Pads	Warm	4
14	A14	Pan Sphere	Pads	Warm	4
15	A15	Square	Pads	Analg	2
16	A16	Shaper	Pads	Brite	2
17	B01	Early Digital	Pads	Warm	3
18	B02	Dramana	Pads	Brite	3
19	B03	Dream Shift	Pads	Brite	4
20	B04	Remote Space	Pads	Warm	2
21	B05	Fathoms	Pads	Warm	4
22	B06	SY22 2007	Pads	Warm	1
23	B07	Mother Earth	Pads	Warm	3
24	B08	Landing Pad	Pads	Warm	2
25	B09	The Breath	Pads	Brite	4
26	B10	Humanity	Pads	Warm	2
27	B11	Vowel Pad	Pads	Choir	4
28	B12	Feather Pad	Pads	Brite	2
29	B13	Slow Attack Pad	Pads	Brite	2
30	B14	Hi Brite	Pads	Brite	2
31	B15	Pad & Syn	Pads	Brite	4
32	B16	Cosmic Swell Pad	Pads	Brite	4
33	C01	Sweet Flange	Pads	Brite	4
34	C02	Waterfall	Pads	Brite	4
35	C03	Phase Pad	Pads	Brite	1
36	C04	Pure Synth	Pads	Brite	4
37	C05	Pearls	Pads	Brite	4
38	C06	Flange Wall	Pads	Brite	1
39	C07	Tornado	Pads	Brite	2
40	C08	Ice Rink	Pads	Brite	4
41	C09	Turbulence	Pads	Brite	1
42	C10	Bell Pad	Pads	Brite	4
43	C11	Paradise	Pads	Brite	1
44	C12	Yellow River	Pads	Brite	4
45	C13	Love Me	Pads	Brite	4
46	C14	Frozen Pad	Pads	Brite	4
47	C15	Pensive	Pads	Warm	4
48	C16	Space Vocals	Pads	Choir	3
49	D01	Haah Pad	Pads	Choir	4
50	D02	Oooh Pad	Pads	Choir	4
51	D03	Back in Itopian	Pads	Choir	4
52	D04	Strings & Choir	Pads	Choir	4
53	D05	Angel Eyes	Pads	Choir	3
54	D06	Glass Choir	Pads	Choir	4
55	D07	Nativity	Pads	Choir	4
56	D08	Seraphim	Pads	Choir	4
57	D09	Analog Shine	Pads	Arp	2
58	D10	Cosmic Gate	Pads	Arp	4
59	D11	Catching Wild Horses	Pads	Arp	2
60	D12	High Pass Gate	Pads	Arp	2
61	D13	Rhythmic Filterpad 1	Pads	Arp	2
62	D14	Rhythmic Filterpad 2	Pads	Arp	2
63	D15	P5 Resonance Comp	SyCmp	Analg	3
64	D16	P5 Analog Punch	SyCmp	Analg	3

Number		Voice Name	Category		Element
			Main	Sub	
65	E01	Cool Trance	SyCmp	Analg	2
66	E02	>Attack<	SyCmp	Analg	2
67	E03	Club Finger	SyCmp	Analg	3
68	E04	Wobbly AS2	SyCmp	Analg	2
69	E05	Ana Dayz	SyCmp	Analg	4
70	E06	Airy Nylon	SyCmp	Analg	4
71	E07	Progressive Attack	SyCmp	Analg	3
72	E08	Oracle	SyCmp	Analg	3
73	E09	Big Comp	SyCmp	Digtl	4
74	E10	Rezz Punch	SyCmp	Digtl	4
75	E11	Resonant Clavi	SyCmp	Digtl	1
76	E12	Straight	SyCmp	Digtl	3
77	E13	Psych Noise	SyCmp	Digtl	4
78	E14	Squiffy Misbehaving	SyCmp	Digtl	3
79	E15	Lektro Codes	SyCmp	Digtl	3
80	E16	Hard FM Keys	SyCmp	Digtl	2
81	F01	W Phaser	SyCmp	Digtl	2
82	F02	DPCM Attack	SyCmp	Digtl	2
83	F03	Talk	SyCmp	Digtl	3
84	F04	Digy_SEQ	SyCmp	Arp	3
85	F05	Nerve Nasty	SyCmp	Arp	3
86	F06	Ring_Zplus	SyCmp	Digtl	2
87	F07	Trance Attack	SyCmp	Digtl	3
88	F08	Tekno Attack AF1&2	SyCmp	Digtl	3
89	F09	PWM Percussion	SyCmp	Digtl	2
90	F10	Stabby	SyCmp	Digtl	3
91	F11	Detroit Stab	SyCmp	Digtl	3
92	F12	Corrado	SyCmp	Digtl	3
93	F13	Synthetique	SyCmp	Digtl	1
94	F14	Noiz Rezz	SyCmp	Digtl	3
95	F15	Tuxedo	SyCmp	Digtl	4
96	F16	Queens	SyCmp	Digtl	3
97	G01	Hip Voice	SyCmp	Digtl	2
98	G02	GX1	SyCmp	Fade	4
99	G03	Night Watch	SyCmp	Fade	3
100	G04	Pluck Bells	SyCmp	Fade	4
101	G05	Power Dance Chords	SyCmp	Hook	4
102	G06	Hyper Trance	SyCmp	Digtl	4
103	G07	Cosmic Psyche	SyCmp	Digtl	3
104	G08	Chillin' Chords	SyCmp	Arp	2
105	G09	Dirty Chordz	SyCmp	Arp	4
106	G10	Wild Horses	SyCmp	Arp	3
107	G11	Sixpack AF1&2	SyCmp	Arp	1
108	G12	Percussive Chords	SyCmp	Arp	2
109	G13	Chordmaster	SyCmp	Arp	2
110	G14	In the Mirror	SyCmp	Arp	1
111	G15	Come together!	SyCmp	Arp	1
112	G16	Happy Hour	SyCmp	Arp	2
113	H01	Recycling	SyCmp	Arp	2
114	H02	Digital Dreaming	SyCmp	Arp	4
115	H03	Carpenter's Wife	SyCmp	Arp	1
116	H04	Electronic Games	SyCmp	Arp	2
117	H05	Dancing Waves	SyCmp	Arp	1
118	H06	Hit Factory	SyCmp	Arp	1
119	H07	Freaky Loop	SyCmp	Arp	1
120	H08	Mr. Wah!	SyCmp	Arp	2
121	H09	Chill Comp 1	SyCmp	Arp	1
122	H10	Chill Comp 2	M.EFX	Arp	1
123	H11	Kalimboidal	SyCmp	Arp	2
124	H12	Bippus	SyCmp	Arp	2
125	H13	Virtuoso Sequencia	SyCmp	Arp	3
126	H14	Fat Saw Arpeggio	SyCmp	Arp	2
127	H15	Trancious Line	SyCmp	Arp	1
128	H16	Metal Plate	SyCmp	Arp	3

PRE7 (MSB=63, LSB=6)

Number		Voice Name	Category		Element
			Main	Sub	
1	A01	Fifth Dancer	SyCmp	Arp	2
2	A02	Percussive Sequence	SyCmp	Arp	1
3	A03	Simply Faaat	SyCmp	Arp	2
4	A04	Bright Dance	SyCmp	Arp	2
5	A05	Quadro Tune	SyCmp	Arp	4
6	A06	Champ	SynLd	Arp	2
7	A07	Men In Yellow	S.EFX	Move	4
8	A08	Metamorphosis	S.EFX	Move	2
9	A09	Perplex	S.EFX	Move	2
10	A10	Outer Planet	S.EFX	Move	2
11	A11	Industrial	S.EFX	Move	2
12	A12	Space Walking	S.EFX	Move	1
13	A13	Scraper	S.EFX	Move	1
14	A14	SE_02 <Zero Two>	S.EFX	Move	3
15	A15	Talking Machines	S.EFX	Move	2
16	A16	Tobi Mage	S.EFX	Move	3
17	B01	Bitzz MW	S.EFX	Move	1
18	B02	Thexism	S.EFX	Move	4
19	B03	In My Head	S.EFX	Move	4
20	B04	Toda	S.EFX	Ambie	3
21	B05	Water Tank	S.EFX	Ambie	3
22	B06	Auto Trapeze	S.EFX	Ambie	4
23	B07	Harpist's Nightmare	S.EFX	Ambie	2
24	B08	Find Newgt!	S.EFX	Ambie	4
25	B09	Nile River	S.EFX	Natur	1
26	B10	New Age Atmo	S.EFX	Natur	4
27	B11	Wind Blows	S.EFX	Natur	4
28	B12	Fire!	S.EFX	Natur	4
29	B13	Scratching Machine	S.EFX	SciFi	2
30	B14	Goa Psyche	S.EFX	SciFi	2
31	B15	Wait For Bad Weather	S.EFX	SciFi	3
32	B16	Reverse The Audio	S.EFX	SciFi	2
33	C01	Radio Static	S.EFX	SciFi	2
34	C02	Modifier X	S.EFX	SciFi	2
35	C03	Surveillance	S.EFX	SciFi	1
36	C04	Noise FX	S.EFX	SciFi	1
37	C05	Sample&Hold Vintage	S.EFX	SciFi	1
38	C06	Lazerzz	S.EFX	SciFi	2
39	C07	uhohrr	S.EFX	SciFi	2
40	C08	On The Fritz	S.EFX	SciFi	1
41	C09	Scratch Thing MW	S.EFX	Arp	1
42	C10	Trash Can Lid Band	S.EFX	Arp	4
43	C11	Piston Engine	S.EFX	Arp	3
44	C12	Waka Waka Noize	S.EFX	Arp	4
45	C13	Argentina	S.EFX	SciFi	4
46	C14	Gate of Eden	M.EFX	Move	4
47	C15	Wave Journey	M.EFX	Move	8
48	C16	Whispering Ghosts	M.EFX	Move	4
49	D01	Nighttrain to Munich	M.EFX	Move	4
50	D02	Morning Dew	M.EFX	Move	4
51	D03	Calling Mr. Reso	M.EFX	Move	4
52	D04	2 Switches to Heaven	M.EFX	Move	4
53	D05	Cell Division	M.EFX	Move	1
54	D06	Jumping Needle	M.EFX	Move	1
55	D07	SEKAI-ISAN	M.EFX	Move	4
56	D08	Setsunai AF2	M.EFX	Move	4
57	D09	Week End	M.EFX	Move	4
58	D10	Dragonfly	S.EFX	SciFi	2
59	D11	TiRiPAD	M.EFX	Move	4
60	D12	Cluster	M.EFX	Move	4
61	D13	Xtreme Rezz	M.EFX	Move	4
62	D14	Bit Space	M.EFX	Move	3
63	D15	My Reality	M.EFX	Move	4
64	D16	Waterproof	M.EFX	Move	4

Number		Voice Name	Category		Element
			Main	Sub	
65	E01	Magnetics	M.EFX	Move	4
66	E02	Sand	M.EFX	Move	4
67	E03	Felicity	M.EFX	Move	4
68	E04	Vibrancy	M.EFX	Move	4
69	E05	Metallflake	M.EFX	Move	1
70	E06	Radio Venus	M.EFX	Move	4
71	E07	Elec Blue	M.EFX	Move	3
72	E08	Chyo Ethno	M.EFX	Move	4
73	E09	Metal Shaper	M.EFX	Move	1
74	E10	Calculator	M.EFX	Move	1
75	E11	konjoh BEAM	M.EFX	Move	4
76	E12	Blizzard	M.EFX	Ambie	2
77	E13	SINGING BOWL	M.EFX	Ambie	2
78	E14	Vektris	M.EFX	Ambie	1
79	E15	Metalvox Pad	M.EFX	Ambie	3
80	F01	Refraction	M.EFX	Ambie	3
81	F01	Philanger	M.EFX	Ambie	1
82	F02	Slippery Ambience	M.EFX	Move	1
83	F03	Ellipsotron	M.EFX	Move	2
84	F04	Envelope	M.EFX	Move	3
85	F05	Whatsis	M.EFX	Ambie	3
86	F06	Pearl Collection	M.EFX	Ambie	4
87	F07	Four Dimensions	M.EFX	Ambie	1
88	F08	Hallucination	M.EFX	Ambie	1
89	F09	Arctic Sequence	M.EFX	Ambie	1
90	F10	Drifting	M.EFX	Ambie	4
91	F11	Electraid	M.EFX	Ambie	4
92	F12	Bed Time Story	M.EFX	Ambie	2
93	F13	Clearing	M.EFX	Sweep	2
94	F14	Long HiPa	M.EFX	Sweep	4
95	F15	Quad Swell	M.EFX	Sweep	4
96	F16	New Stab	M.EFX	Hit	4
97	G01	Vinyl Hit	M.EFX	Hit	4
98	G02	Hit Me	M.EFX	Hit	4
99	G03	Ambient Bite	M.EFX	Hit	4
100	G04	Green Valley	M.EFX	Arp	4
101	G05	Everlasting Glory	M.EFX	Arp	4
102	G06	Thinking of You	M.EFX	Arp	4
103	G07	Festival of Harmony	M.EFX	Arp	4
104	G08	Paris at Night	M.EFX	Arp	4
105	G09	On my Way to UK	M.EFX	Arp	4
106	G10	Chillin' Ibiza	M.EFX	Arp	3
107	G11	Heavens Door	M.EFX	Arp	4
108	G12	Cocktail	M.EFX	Arp	2
109	G13	Vanilla	M.EFX	Arp	3
110	G14	Ibiza Groove	M.EFX	Arp	4
111	G15	Nylon Chill	M.EFX	Arp	4
112	G16	Xtreme Harp	M.EFX	Arp	3
113	H01	Trancing in the Rain	M.EFX	Arp	4
114	H02	Gated Detune	M.EFX	Arp	2
115	H03	Gated Choir	M.EFX	Arp	4
116	H04	Exotic	M.EFX	Arp	3
117	H05	Syncscraper	M.EFX	Arp	2
118	H06	Ethnotic	M.EFX	Arp	3
119	H07	ComSat	M.EFX	Arp	2
120	H08	Investikator	M.EFX	Arp	1
121	H09	Monkey Bars	M.EFX	Arp	2
122	H10	Chiltrancer	M.EFX	Arp	2
123	H11	Random Beatz	M.EFX	Arp	1
124	H12	Electro Hood	M.EFX	Arp	2
125	H13	My Subwoofers	M.EFX	Arp	3
126	H14	Mister Sinister	M.EFX	Arp	2
127	H15	Polyrhythm	M.EFX	Arp	4
128	H16	Blood Flow	M.EFX	Arp	3

PRE8 (MSB=63, LSB=7)

Number	Voice Name	Category		Element	
		Main	Sub		
1	A01	On The Verge	M.EFX	Arp	3
2	A02	Droid	M.EFX	Arp	2
3	A03	Worker Ant	M.EFX	Arp	4
4	A04	Chopp Lingo	M.EFX	Arp	2
5	A05	Vinyl Beatnik	M.EFX	Arp	4
6	A06	Drop Zone ARP	M.EFX	Arp	2
7	A07	Particle	M.EFX	Arp	2
8	A08	Simple Arp	M.EFX	Arp	1
9	A09	Cyber Cycle	M.EFX	Arp	1
10	A10	BollogPuls	M.EFX	Arp	4
11	A11	Octopus	M.EFX	Arp	2
12	A12	Electronic Beatz	M.EFX	Arp	1
13	A13	Dreamin' of You	M.EFX	Arp	4
14	A14	Brothers & Sisters	M.EFX	Arp	4
15	A15	Pizza No.1	M.EFX	Arp	3
16	A16	Electronix	M.EFX	Arp	2
17	B01	TekkNow	M.EFX	Arp	4
18	B02	Hollow Sequence	M.EFX	Arp	1
19	B03	Icicle	M.EFX	Arp	2
20	B04	Jegog	M.EFX	Arp	1
21	B05	Octo Strobe 1	M.EFX	Arp	1
22	B06	Octo Strobe 2	M.EFX	Arp	1
23	B07	Random Waves	M.EFX	Arp	1
24	B08	Semar	M.EFX	Arp	2
25	B09	Trailing Headlights	M.EFX	Arp	2
26	B10	Dream Winds	M.EFX	Arp	1
27	B11	Kemence	Ethnic	Bowed	2
28	B12	Kemen Wet	Ethnic	Bowed	3
29	B13	Yayli	Ethnic	Bowed	4
30	B14	Kawala	Ethnic	Bowed	1
31	B15	Santur	Ethnic	Struk	2
32	B16	Baglama	Ethnic	Pluk	3
33	C01	Kotoun	Ethnic	Pluk	3
34	C02	Kanun	Ethnic	Pluk	2
35	C03	Bouzuki	Ethnic	Pluk	3
36	C04	Oud Tremolo Vel	Ethnic	Pluk	1
37	C05	SazFeeze	Ethnic	Pluk	3
38	C06	Where Am I?	Ethnic	Pluk	3
39	C07	Sakura	Ethnic	Pluk	3
40	C08	Nomad	Ethnic	Pluk	2
41	C09	Pluk-o-dy	Ethnic	Pluk	3
42	C10	Tambura	Ethnic	Pluk	2
43	C11	Sitar MW	Ethnic	Pluk	2
44	C12	Tabla Zone	Ethnic	Struk	1
45	C13	Udu	Ethnic	Struk	2
46	C14	Djembe	Ethnic	Struk	2
47	C15	Dhol	Ethnic	Struk	2
48	C16	Khol	Ethnic	Struk	3
49	D01	Ney	Ethnic	Blown	1
50	D02	Zurna	Ethnic	Blown	1
51	D03	Pungi	Ethnic	Blown	2
52	D04	Shehnai 1	Ethnic	Blown	2
53	D05	Didgeridoo	Ethnic	Blown	2
54	D06	Snake Charmer	Ethnic	Blown	4
55	D07	Mythic Flute	Ethnic	Blown	4
56	D08	Ethnology	Ethnic	Arp	4
57	D09	Oztralian	Ethnic	Arp	2
58	D10	8Z Destruct	Dr/Pc	Arp	2
59	D11	8Z Jarrin	Dr/Pc	Arp	2
60	D12	8Z Romps	Dr/Pc	Arp	2
61	D13	8Z Glitch	Dr/Pc	Arp	2
62	D14	8Z Oxidized	Dr/Pc	Arp	2
63	D15	8Z D&B Machine	Dr/Pc	Arp	2
64	D16	8Z Down Tempo	Dr/Pc	Arp	2

Number	Voice Name	Category		Element	
		Main	Sub		
65	E01	8Z Early Lo-Fi	Dr/Pc	Arp	1
66	E02	8Z Noize Xpress	Dr/Pc	Arp	1
67	E03	8Z Trance Basics	Dr/Pc	Arp	1
68	E04	8Z Reverse Beatz	Dr/Pc	Arp	1
69	E05	8Z Crush Dance	Dr/Pc	Arp	1
70	E06	8Z Heavy Hearts	Dr/Pc	Arp	1
71	E07	8Z Chilly Breakz	Dr/Pc	Arp	1
72	E08	8Z Gated Beatz	Dr/Pc	Arp	1
73	E09	8Z Hip Hop Shakers	Dr/Pc	Arp	1
74	E10	8Z Blip Hop	Dr/Pc	Arp	1
75	E11	8Z Nastly Glitch	Dr/Pc	Arp	2
76	E12	8Z Scratch	Dr/Pc	Arp	1
77	E13	8Z Tod	Dr/Pc	Arp	1
78	E14	8Z Psychedelic 1	Dr/Pc	Arp	2
79	E15	8Z Psychedelic 2	Dr/Pc	Arp	2
80	E16	8Z Dub Element	Dr/Pc	Arp	2
81	F01	Mega Nylon	Guitar	A.Gtr	2
82	F02	Mega Steel	Guitar	A.Gtr	2
83	F03	Mega 12 Steel	Guitar	A.Gtr	4
84	F04	Mega 60s Clean	Guitar	E.Cln	1
85	F05	Mega 60s Chorus Combo	Guitar	E.Cln	1
86	F06	Mega 60s Tremolo	Guitar	E.Cln	1
87	F07	Mega 60s Blues Tone	Guitar	E.Cln	1
88	F08	Mega 60s Phaser	Guitar	E.Cln	1
89	F09	Mega 60s Tube Tone	Guitar	E.Dst	1
90	F10	Mega 60s Dist Stack	Guitar	E.Dst	1
91	F11	Mega 60s Road House	Guitar	E.Dst	1
92	F12	Mega 60s Small Blues	Guitar	E.Cln	1
93	F13	Mega 60s Pedal Wah	Guitar	E.Dst	1
94	F14	Mega 60s VCM T.Wah	Guitar	E.Dst	1
95	F15	Mega 60s T.Wah&Dist	Guitar	E.Dst	1
96	F16	Mega 60s Jet Flanger	Guitar	E.Dst	1
97	G01	Mega 1coil Clean	Guitar	E.Cln	1
98	G02	Mega 1coil Chorus	Guitar	E.Cln	1
99	G03	Mega 1coil Tremolo	Guitar	E.Cln	1
100	G04	Mega 1coil BluesTone	Guitar	E.Cln	1
101	G05	Mega 1coil Phaser	Guitar	E.Cln	1
102	G06	Mega 1coil Tube Tone	Guitar	E.Cln	1
103	G07	Mega 1coil Tube Amp1	Guitar	E.Dst	1
104	G08	Mega 1coil Tube Amp2	Guitar	E.Dst	1
105	G09	Mega 1coil Roadhouse	Guitar	E.Dst	1
106	G10	Mega 1coil VCM T.Wah	Guitar	E.Cln	1
107	G11	Mega 60s Clean Delay	Guitar	E.Cln	1
108	G12	Mega 60s Slap Clean	Guitar	E.Cln	1
109	G13	Mega 60s Slap Dist	Guitar	E.Cln	1
110	G14	Mega 1coil SlapClean	Guitar	E.Cln	1
111	G15	Mega 1coil Slap Dist	Guitar	E.Dst	1
112	G16	Mega1coilSlpPedalWah	Guitar	E.Cln	1
113	H01	Mega Ovdr Distortion	Guitar	E.Dst	2
114	H02	Mega Ovdr Fuzz	Guitar	E.Dst	2
115	H03	Mega Acoustic Bass	Bass	ABass	1
116	H04	Mega Finger+Harmonic	Bass	EBass	1
117	H05	Mega Fretless Bass	Bass	EBass	1
118	H06	Mega Pick Open Amped	Bass	EBass	1
119	H07	Mega Pick Mute Amped	Bass	EBass	1
120	H08	Mega Slap Bass	Bass	EBass	1
121	H09	Mega Finger+Slap	Bass	EBass	1
122	H10	Mega Finger+Pull Amp	Bass	EBass	1
123	H11	Mega Pick Open Mute	Bass	EBass	1
124	H12	Mega Pick OpMt Dark	Bass	EBass	1
125	H13	Vocoder with Delay	Vocoder	---	4
126	H14	Funky Vocoder	Vocoder	---	4
127	H15	Vocoder Pad 1	Vocoder	---	5
128	H16	Vocoder Pad 2	Vocoder	---	4

PRE9 (MSB=63, LSB=8)

Number		Voice Name	Category		Element
			Main	Sub	
1	A01	Natural Grand S6	Piano	APno	2
2	A02	Piano Rock S6	Piano	Modrn	2
3	A03	Woody Piano S6	Piano	Vintg	2
4	A04	Intimate S6	Piano	Vintg	2
5	A05	Clavi Brill Treble	Keys	Clavi	1
6	A06	Clavi Amped	Keys	Clavi	1
7	A07	Clavi Phaser	Keys	Clavi	1
8	A08	Clavi Touch Wah	Keys	Clavi	1
9	A09	Clavi PedalWah MW	Keys	Clavi	1
10	A10	Natural Harpsichord	Keys	Clavi	8
11	A11	Octave Harpsichord	Keys	Clavi	8
12	A12	Vx Full Bars	Organ	Combo	4
13	A13	Vx Dark Bars	Organ	Combo	3
14	A14	Fr All Tabs	Organ	Combo	1
15	A15	Fr Bright Boost	Organ	Combo	3
16	A16	Fr String Tabs	Organ	Combo	3
17	B01	Vx Full Bars Amped	Organ	Combo	4
18	B02	Vx Surf Organ	Organ	Combo	4
19	B03	Fr Raspy Tabs	Organ	Combo	3
20	B04	Master Accordion	Organ	Pipe	1
21	B05	French Musette	Organ	Pipe	1
22	B06	Cassotto	Organ	Pipe	1
23	B07	Tango Accordion 2	Organ	Pipe	1
24	B08	Vibraphone	CPerc	Malet	1
25	B09	Vibraphone Soft	CPerc	Malet	1
26	B10	Tubular Bell 2	CPerc	Bell	1
27	B11	Real Timpani AF2 Mfl	CPerc	Malet	2
28	B12	1coil Clean AF1&2	Guitar	E.Cln	1
29	B13	1coil Amped Vel	Guitar	E.Cln	1
30	B14	Vintage 1coil Chorus	Guitar	E.Cln	1
31	B15	Surfin' 60s 1coil	Guitar	E.Cln	1
32	B16	Breakback Mountain	Guitar	E.Dst	1
33	C01	Grunged Up	Guitar	E.Dst	4
34	C02	Jazz Clean AF1&2	Guitar	E.Cln	1
35	C03	Arched Top	Guitar	E.Cln	1
36	C04	Jazz Blues	Guitar	E.Cln	1
37	C05	Round Wound Finger	Bass	EBass	1
38	C06	Tube Finger Bass	Bass	EBass	1
39	C07	Slightly Grunged	Bass	EBass	1
40	C08	Prec Pick	Bass	EBass	1
41	C09	Pick Amp	Bass	EBass	1
42	C10	Universal AF1&2	Bass	SynBs	1
43	C11	Analog Bullet Bass	Bass	SynBs	3
44	C12	Analog Perc Bass	Bass	SynBs	3
45	C13	Analog Step Bass	Bass	SynBs	3
46	C14	Short Buzz AF1&2	Bass	Arp	3
47	C15	Bass Machine AF1	Bass	Arp	1
48	C16	Deep Ramp AF1&2	Bass	Arp	1
49	D01	Section Strings 1	String	Ensem	5
50	D02	Section Strings 2	String	Ensem	2
51	D03	Section Strings 3	String	Ensem	4
52	D04	Section Strings 4	String	Ensem	4
53	D05	Tremolo Section	String	Ensem	2
54	D06	Pizzicato Vel	String	Pizz	2
55	D07	Orchestra Harp	String	Pizz	2
56	D08	Harp Ambient	String	Pizz	2
57	D09	Gleaming Pad AF1&2	String	Synth	2
58	D10	Fat PWM Synth Vel	String	Synth	2
59	D11	Vintage Polystrings	String	Synth	3
60	D12	Soft Trumpet Legato	Brass	Solo	1
61	D13	Trumpet Vibrato	Brass	Solo	1
62	D14	Trumpet Shake Vel	Brass	Solo	1
63	D15	French Horn Section2	Brass	Orche	2
64	D16	Flugelhorn	Brass	Solo	1

Number		Voice Name	Category		Element
			Main	Sub	
65	E01	Jazz Brass Section	Brass	BrsEn	5
66	E02	Ob Syncomp	Brass	Synth	2
67	E03	Tacky Brass AF1&2	Brass	Synth	2
68	E04	Mellow Soprano	SaxWW	Sax	1
69	E05	Alto Accent Legato	SaxWW	Sax	1
70	E06	Tenor Max	SaxWW	Sax	1
71	E07	Soft TenorSax Legato	SaxWW	Sax	1
72	E08	Piccolo Legato	SaxWW	Flute	2
73	E09	Bizz AF2	SynLd	Arp	2
74	E10	The Bitch AF1&2	SynLd	Arp	3
75	E11	Mellow Swell AF1&2	Pads	Warm	4
76	E12	Frozen Glasspad	Pads	Warm	4
77	E13	Lunar Eclipse AF1&2	Pads	Brite	4
78	E14	Melting Steel AF1&2	Pads	Choir	2
79	E15	Prayer Call	Pads	Choir	3
80	E16	Bass n' Gate	Pads	Arp	2
81	F01	PWM Stabs	SyCmp	Analg	2
82	F02	Queen of Pop AF1&2	SyCmp	Analg	4
83	F03	Multi Bell	SyCmp	Arp	4
84	F04	Acid 'n Space AF1&2	SyCmp	Arp	2
85	F05	Middle Ear AF1&2	SyCmp	Arp	3
86	F06	Badger AF1&2	SyCmp	Arp	1
87	F07	Voodoo Wah	SyCmp	Arp	2
88	F08	Jumping Wheel AF1&2	SyCmp	Arp	1
89	F09	Devils Wah AF1&2	SyCmp	Arp	1
90	F10	Horizons AF1&2	SyCmp	Arp	1
91	F11	Hypnotic AF1&2	SyCmp	Arp	1
92	F12	Airy Buzz AF1&2	SyCmp	Arp	1
93	F13	TranciousStepz AF1&2	SyCmp	Arp	4
94	F14	Trilogy AF1&2	SyCmp	Arp	2
95	F15	PWM Picks AF1&2	SyCmp	Arp	4
96	F16	VariChord AF1&2	SyCmp	Arp	1
97	G01	Voxdance AF1&2	SyCmp	Arp	4
98	G02	Spacewave Dancer	S.EFX	Arp	7
99	G03	Berimbau Ookawatou	M.EFX	Arp	6
100	G04	Club Telemetrix	M.EFX	Arp	3
101	G05	Venusian Rhumba	M.EFX	Arp	1
102	G06	Dripping Quarks	M.EFX	Ambie	3
103	G07	Undulator	M.EFX	Ambie	4
104	G08	Expanse	M.EFX	Ambie	4
105	G09	Deep Motion AF1&2	M.EFX	Ambie	4
106	G10	Metallic Airstabs	M.EFX	Ambie	2
107	G11	Descendant	M.EFX	Ambie	4
108	G12	Angel in Love	M.EFX	Arp	4
109	G13	Berlin Dreamz	M.EFX	Arp	2
110	G14	Complexions AF1&2	M.EFX	Arp	3
111	G15	Crazy Groove AF1&2	M.EFX	Arp	2
112	G16	Da Thumperz	M.EFX	Arp	6
113	H01	Meister Chilla	M.EFX	Arp	3
114	H02	X-Generator AF1&2	M.EFX	Move	2
115	H03	GlaringMessage AF1&2	M.EFX	Arp	5
116	H04	Sitar 2	Ethnc	Pluk	2
117	H05	India Harmonium	Ethnc	--	5
118	H06	Berimbau	Ethnc	Struk	1
119	H07	Banjo 2	Ethnc	Pluk	2
120	H08	Nu Orc Percussion	Dr/Pc	Perc	2
121	H09	8Z Cajon	Dr/Pc	Arp	2
122	H10	8Z Djembe	Dr/Pc	Arp	1
123	H11	8Z Static	Dr/Pc	Arp	2
124	H12	8Z RX11	Dr/Pc	Arp	1
125	H13	8Z Trance Basics 2	Dr/Pc	Arp	1
126	H14	8Z Tom Heartz	Dr/Pc	Arp	2
127	H15	Mega 1coil Old R&R	Guitar	E.Cln	1
128	H16	Mega Jazz Guitar	Guitar	E.Cln	1

USR1 (MSB=63, LSB=9)

USR2 (MSB=63, LSB=10)

USR3 (MSB=63, LSB=11)

Any of the Preset Voices is pre-stored to each voice number of the User Banks.

GM (MSB=0, LSB=0)

Number		Voice Name	Category		Element
			Main	Sub	
1	A01	Concert Grand Piano	Piano	APno	2
2	A02	Rock Brite Piano	Piano	APno	1
3	A03	CP 2007	Piano	Vintg	1
4	A04	Honkytonk	Piano	APno	4
5	A05	E.Piano 1	Keys	EP	1
6	A06	E.Piano 2	Keys	FM	2
7	A07	Harpsichord	Keys	Clavi	1
8	A08	Brite Clavi	Keys	Clavi	1
9	A09	Celesta	CPerc	Malet	1
10	A10	Glocken	CPerc	Malet	1
11	A11	Music Box	CPerc	Bell	3
12	A12	Vibes	CPerc	Malet	2
13	A13	Marimba	CPerc	Malet	2
14	A14	Xylophone	CPerc	Malet	2
15	A15	Tubular Bell	CPerc	Bell	3
16	A16	Dulcimer	CPerc	PDrum	2
17	B01	Draw Organ	Organ	TnWhl	2
18	B02	Percussive Organ	Organ	TnWhl	2
19	B03	Rock Organ	Organ	TnWhl	2
20	B04	Church Organ	Organ	Pipe	3
21	B05	Reed Organ	Organ	Pipe	2
22	B06	Accordion	Organ	Pipe	1
23	B07	Harmonica	SaxWW	RPipe	1
24	B08	Tango Accordion	Organ	Pipe	1
25	B09	Nylon Guitar	Guitar	A.Gtr	2
26	B10	Steel Guitar	Guitar	A.Gtr	2
27	B11	Jazz Guitar	Guitar	E.Cln	2
28	B12	Clean Guitar	Guitar	E.Cln	1
29	B13	Mute Guitar	Guitar	E.Cln	1
30	B14	Overdrive Guitar	Guitar	E.Dst	2
31	B15	Distortion Guitar	Guitar	E.Dst	2
32	B16	Guitar Harmonics	Guitar	E.Dst	2
33	C01	Acoustic Bass	Bass	ABass	1
34	C02	Finger Bass	Bass	EBass	2
35	C03	Pick Bass	Bass	EBass	2
36	C04	Fretless Bass	Bass	EBass	1
37	C05	Slap Bass 1	Bass	EBass	1
38	C06	Slap Bass 2 vel	Bass	EBass	1
39	C07	Synth Bass 1	Bass	SynBs	2
40	C08	Synth Bass 2	Bass	SynBs	2
41	C09	Violin	String	Solo	3
42	C10	Viola	String	Solo	3
43	C11	Cello	String	Solo	2
44	C12	Contrabass	String	Solo	2
45	C13	Tremolo Strings 2	String	Ensem	2
46	C14	Pizzicato	String	Pizz	2
47	C15	Harp	String	Pizz	1
48	C16	Timpani + Cymbal	CPerc	PDrum	4
49	D01	Strings Section 1	String	Ensem	2
50	D02	Strings Section 2	String	Ensem	2
51	D03	Synth Strings 1	String	Synth	3
52	D04	Synth Strings 2	String	Synth	3
53	D05	Aah Choir	Pads	Choir	2
54	D06	Ooh Choir	Pads	Choir	2
55	D07	Syn Voice	Pads	Choir	3
56	D08	Orchestra Hit	M.EFX	Hit	4
57	D09	Trumpet 2	Brass	Solo	1
58	D10	Trombone 2	Brass	Solo	1
59	D11	Tuba	Brass	Solo	1
60	D12	Mute Trumpet	Brass	Solo	1
61	D13	French Horns	Brass	Orche	2
62	D14	Brass Section	Brass	BrsEn	3
63	D15	Synth Brass 1	Brass	Synth	3
64	D16	Synth Brass 2	Brass	Synth	3

Number		Voice Name	Category		Element
			Main	Sub	
65	E01	Soprano Sax	SaxWW	Sax	3
66	E02	Alto Sax	SaxWW	Sax	1
67	E03	Tenor Sax	SaxWW	Sax	2
68	E04	Baritone Sax	SaxWW	Sax	1
69	E05	Oboe 2	SaxWW	RPipe	2
70	E06	English Horn	SaxWW	RPipe	1
71	E07	Bassoon 2	SaxWW	RPipe	2
72	E08	Clarinet 2	SaxWW	RPipe	3
73	E09	Piccolo	SaxWW	Flute	1
74	E10	Flute	SaxWW	Flute	2
75	E11	Recorder	SaxWW	WWind	1
76	E12	Panflute	SaxWW	Flute	1
77	E13	Bottle	SaxWW	Flute	2
78	E14	Shakuhachi	SaxWW	Flute	2
79	E15	Whistle	SaxWW	WWind	2
80	E16	Ocarina	SaxWW	WWind	2
81	F01	Square Lead	SynLd	Analg	2
82	F02	Saw Lead	SynLd	Analg	2
83	F03	Calliope Lead	SynLd	Analg	2
84	F04	Chiff Lead	SynLd	Analg	1
85	F05	Charan Lead	SynLd	Digitl	2
86	F06	Voice Lead	SynLd	Analg	4
87	F07	Fifth Lead	SynLd	Analg	2
88	F08	Bass & Lead	SynLd	Analg	1
89	F09	New Age Pad	Pads	Brite	2
90	F10	Warm Pad	Pads	Warm	2
91	F11	Poly Synth Pad	Pads	Analg	2
92	F12	Choir Pad	Pads	Choir	3
93	F13	Bowed Pad	Pads	Warm	2
94	F14	Metal Pad	Pads	Brite	2
95	F15	Halo Pad	Pads	Brite	2
96	F16	Sweep Pad	Pads	Brite	4
97	G01	Rain Pad	M.EFX	Move	2
98	G02	Sound Track	Pads	Brite	3
99	G03	Crystal	CPerc	Bell	3
100	G04	Atmosphere	Pads	Warm	3
101	G05	Brightness	SyCmp	Digitl	2
102	G06	Goblin	M.EFX	Sweep	2
103	G07	Echoes	M.EFX	Move	3
104	G08	Sci-Fi	Pads	Brite	2
105	G09	Sitar	Ethnic	Pluk	1
106	G10	Banjo	Ethnic	Pluk	1
107	G11	Shamisen	Ethnic	Pluk	1
108	G12	Koto	Ethnic	Pluk	2
109	G13	Kalimba	CPerc	Malet	2
110	G14	Bagpipe	SaxWW	RPipe	2
111	G15	Fiddle	Ethnic	Bowed	2
112	G16	Shehnai 2	SaxWW	WWind	1
113	H01	Tinkle Bell	CPerc	Bell	2
114	H02	Agogo	Dr/Pc	Perc	1
115	H03	Steel Drum	CPerc	PDrum	2
116	H04	Woodblock	Dr/Pc	Perc	1
117	H05	Taiko Drum	Dr/Pc	Perc	2
118	H06	Melodic Tom	Dr/Pc	Drums	1
119	H07	Synth Drum	Dr/Pc	Drums	1
120	H08	Reverse Cymbal	S.EFX	Move	1
121	H09	Fret Noise	S.EFX	Natur	2
122	H10	Breath Noiz	S.EFX	Natur	1
123	H11	Seashore	S.EFX	Natur	2
124	H12	Tweet	S.EFX	Natur	1
125	H13	Telephone	S.EFX	Natur	1
126	H14	Helicopter	S.EFX	Natur	2
127	H15	Applause	S.EFX	Natur	2
128	H16	Gunshot	S.EFX	Natur	1

Drum Voice List

Drum Voice Name List

Preset (MSB=63, LSB=32)

Pre No.	Voice Name	
1	Power Standard Kit 1	A
2	Power Standard Kit 2	A
3	Hyper Standard Kit	A
4	Dry Standard Kit	A
5	Modern Rock Kit	A
6	Rock Stereo Kit 1	A
7	Rock Stereo Kit 2	A
8	Nu Hip Hop Kit 1	A
9	Nu Hip Hop Kit 2	A
10	Hip Hop Kit 1	A
11	Hip Hop Kit 2	A
12	Hip Hop Kit 3	A
13	Hip Hop Kit 4	A
14	Hip Stick Kit 1	A
15	Hip Stick Kit 2	A
16	R&B Kit 1	A
17	R&B Kit 2	A
18	R&B Kit 3	A
19	Trance Kit	A
20	Psychedelic Kit	A
21	Chill Out Kit	A
22	Brush Kit	A
23	Jazz Kit	A
24	Pop Latin Kit	A
25	Analog T9 Kit	A
26	Analog T8 Kit	A
27	Tekno Kit	A
28	House Kit 1	A
29	House Kit 2	A
30	House Compressed Kit	A
31	Big Kit	A
32	Break Kit	A
33	Drum'n'Bass Kit	A
34	Acid Kit	A
35	Jungle Kit	A
36	Electric Kit	A
37	Human Kit	A
38	Hard Kit	A
39	Distorted Kit	A
40	Ambient Kit	A
41	Garage Kit	B
42	Synth Pop Kit	B
43	Orchestra Kit	B
44	Drum Machines Kit	B
45	Rock Multiple Kits	B
46	HipHop Multiple Kits	B
47	Percussion Kit	C
48	Latin Percussion Kit	C
49	Guitar/Bass FX Kit	C
50	Wacko Kit	C
51	Wood Bits Kit	C
52	Metal Bits Kit	C
53	Hands Kit	C
54	Scratches	C
55	Acoustic Snares	C
56	GroupedStereo Snares	C
57	All Kicks	C
58	Dance Kicks	C
59	Arabic Mixed Kit	C
60	Belly Dance Kit	C
61	Dance Snares	C
62	Special SFXs	C
63	Synthetic Kit	C
64	SFX Kit	C
65	Maple Custom Kit	A
66	Oak Custom Kit	A
67	Nu Jazzy Kit	A
68	Illest Hip Hop Kit	A
69	PercussionMaster Kit	A
70	Nu Orchestra Kit	C
71	Japan Kit	B
72	Turkish Kit	C

GM (MSB=127, LSB=0)

GM Drum No.	Voice Name	
1	Stereo GM Kit	A

A:
These drum kits have been specially programmed for different music styles, yet closely follow the standard instrument order of the GM kit.

B:
These original drum kits, programmed for the MOXF6/MOXF8, feature a special non-standard order for ease in playing.

C:
These original kits feature a variety of instruments and special sound effects, and are grouped according to their type.

Drum Kit Assign List

PDR 1 Power Standard Kit 1

Note	Wave Number	Wave Name
C0	2106	Claves1
C#0	3205	Sd Brush Soft St
D0	3217	Sd Brush Swir St
D#0	3208	Sd Brush Med St
E0	3220	Sd Brush SwirAtt St
F0	3201	Sd LiveRoll St
F#0	1935	Castanet1
G0	3029	Sd PowerD 1St
G#0	1933	Stick1
A0	2555	Bd PowerB 1-2St
A#0	3041	Sd PowerD 5St
B0	2546	Bd PowerA 1-2St
C1	2534	Bd Jazz1-2St
C#1	2999	Sd PowerB SSt
D1	3002	Sd PowerC 1-5St
D#1	1945	Hand Clap1 St
E1	3023	Sd PowerD 1-5St
F1	3703	Tom Power05 1-2St
F#1	3471	HH Power ClTip 1-4St
G1	3703	Tom Power05 1-2St
G#1	3511	HH Power ClPedal St
A1	3691	Tom Power04 1-2St
A#1	3515	HH Power Open EdgeSt
B1	3679	Tom Power03 1-2St
C2	3679	Tom Power03 1-2St
C#2	3867	Crash2 St
D2	3667	Tom Power01 1-2St
D#2	3907	Ride1 St
E2	3954	China1 St
F2	3935	Ride Cup1 St
F#2	1927	Tambourine1 Sw
G2	3963	Splash1 St
G#2	2110	Cowbell2
A2	3870	Crash2 RL
A#2	1940	Vibraslap1
B2	3911	Ride2 St
C3	2007	Bongo1 Hi 1Fingr 1-2
C#3	2017	Bongo1 Lo 1Fingr 1-2
D3	1974	Conga1 Hi SlpMute1-2
D#3	1968	Conga1 Hi Open 1-2
E3	1979	Conga1 Lo Open 1-2
F3	2033	Timbale1 Hi 1-3
F#3	2037	Timbale1 Lo 1-2
G3	2080	Agogo Hi
G#3	2081	Agogo Lo
A3	2059	CabasaA 1-2
A#3	2057	Maracas Slur
B3	2108	Whistle
C4	2108	Whistle
C#4	2084	Guiro Short
D4	2083	Guiro Long
D#4	2106	Claves1
E4	1939	Wood Block
F4	1939	Wood Block
F#4	2006	Cuica Hi
G4	2005	Cuica Lo
G#4	1944	Triangle Mute
A4	1943	Triangle Open
A#4	1916	ShakerA 1/3
B4	1954	Sleigh Bell1
C5	1957	Wind Chime
C#5	2718	Sd Bld St1-4
D5	2877	Sd Blues 3St
D#5	2921	Sd Hip St1-2
E5	2818	Sd Funk St1-3
F5	2738	Sd Soul St1-4
F#5	3169	Sd LdwHMMono
G5	3172	Sd Heavy
G#5	2901	Sd Tight St1-4
A5	2886	Sd BluesHeart St1-3
A#5	2460	Bd Snap 1-2
B5	2469	Bd Tight 1-2
C6	2496	Bd Funk St1-2

PDR 2 Power Standard Kit 2

Note	Wave Number	Wave Name
C0	2106	Claves1
C#0	3205	Sd Brush Soft St
D0	3217	Sd Brush Swir St
D#0	3208	Sd Brush Med St
E0	3220	Sd Brush SwirAtt St
F0	3201	Sd LiveRoll St
F#0	1935	Castanet1
G0	2963	Sd PowerA 1St
G#0	1933	Stick1
A0	2555	Bd PowerB 1-2St
A#0	2975	Sd PowerA 5St
B0	2546	Bd PowerA 1-2St
C1	2534	Bd Jazz1-2St
C#1	2999	Sd PowerB SSt
D1	2978	Sd PowerB 1-5St
D#1	1945	Hand Clap1 St
E1	2957	Sd PowerA 1-5St
F1	3703	Tom Power05 1-2St
F#1	3491	HH Power ClEdge1-4St
G1	3703	Tom Power05 1-2St
G#1	3511	HH Power ClPedal St
A1	3691	Tom Power04 1-2St
A#1	3515	HH Power Open EdgeSt
B1	3679	Tom Power03 1-2St
C2	3679	Tom Power03 1-2St
C#2	3867	Crash2 St
D2	3667	Tom Power01 1-2St
D#2	3907	Ride1 St
E2	3954	China1 St
F2	3935	Ride Cup1 St
F#2	1927	Tambourine1 Sw
G2	3963	Splash1 St
G#2	2110	Cowbell2
A2	3870	Crash2 RL
A#2	1940	Vibraslap1
B2	3911	Ride2 St
C3	2007	Bongo1 Hi 1Fingr 1-2
C#3	2017	Bongo1 Lo 1Fingr 1-2
D3	1974	Conga1 Hi SlpMute1-2
D#3	1968	Conga1 Hi Open 1-2
E3	1979	Conga1 Lo Open 1-2
F3	2033	Timbale1 Hi 1-3
F#3	2037	Timbale1 Lo 1-2
G3	2080	Agogo Hi
G#3	2081	Agogo Lo
A3	2059	CabasaA 1-2
A#3	2057	Maracas Slur
B3	2108	Whistle
C4	2108	Whistle
C#4	2084	Guiro Short
D4	2083	Guiro Long
D#4	2106	Claves1
E4	1939	Wood Block
F4	1939	Wood Block
F#4	2006	Cuica Hi
G4	2005	Cuica Lo
G#4	1944	Triangle Mute
A4	1943	Triangle Open
A#4	1916	ShakerA 1/3
B4	1954	Sleigh Bell1
C5	1957	Wind Chime
C#5	2718	Sd Bld St1-4
D5	2877	Sd Blues 3St
D#5	2921	Sd Hip St1-2
E5	2818	Sd Funk St1-3
F5	2738	Sd Soul St1-4
F#5	3169	Sd LdwHMMono
G5	3172	Sd Heavy
G#5	2901	Sd Tight St1-4
A5	2886	Sd BluesHeart St1-3
A#5	2460	Bd Snap 1-2
B5	2469	Bd Tight 1-2
C6	2496	Bd Funk St1-2

PDR 3 Hyper Standard Kit

Note	Wave Number	Wave Name
C0	2106	Claves1
C#0	3205	Sd Brush Soft St
D0	3217	Sd Brush Swir St
D#0	3208	Sd Brush Med St
E0	3220	Sd Brush SwirAtt St
F0	3201	Sd LiveRoll St
F#0	1935	Castanet1
G0	2804	Sd Normal 1St
G#0	1933	Stick1
A0	2517	Bd Funk Son St
A#0	2836	Sd Basic St1-3
B0	2461	Bd Snap 1
C1	2511	Bd H Son St
C#1	3190	Sd Closed Rim St
D1	2851	Sd SonA St1-4
D#1	2423	Clap T9
E1	2901	Sd Tight St1-4
F1	3651	Tom Floor St
F#1	3420	HH Closed Foot St
G1	3651	Tom Floor St
G#1	3424	HH Half Open2 St
A1	3647	Tom Low St
A#1	3428	HH Open2 St
B1	3647	Tom Low St
C2	3643	Tom Mid St
C#2	3870	Crash2 RL
D2	3639	Tom Hi St
D#2	3907	Ride1 St
E2	3954	China1 St
F2	3935	Ride Cup1 St
F#2	1927	Tambourine1 Sw
G2	3963	Splash1 St
G#2	2110	Cowbell2
A2	3870	Crash2 RL
A#2	1940	Vibraslap1
B2	3910	Ride1 RL
C3	2007	Bongo1 Hi 1Fingr 1-2
C#3	2020	Bongo1 Lo 3Fingr 1-2
D3	1966	Conga1 Hi Tip
D#3	1970	Conga1 Hi Open 2
E3	2001	Tumba Open
F3	2033	Timbale1 Hi 1-3
F#3	2037	Timbale1 Lo 1-2
G3	2080	Agogo Hi
G#3	2081	Agogo Lo
A3	2059	CabasaA 1-2
A#3	2057	Maracas Slur
B3	2108	Whistle
C4	2108	Whistle
C#4	2084	Guiro Short
D4	2083	Guiro Long
D#4	2106	Claves1
E4	1939	Wood Block
F4	1939	Wood Block
F#4	2006	Cuica Hi
G4	2005	Cuica Lo
G#4	1944	Triangle Mute
A4	1943	Triangle Open
A#4	1917	ShakerA 1
B4	1954	Sleigh Bell1
C5	1957	Wind Chime
C#5	2718	Sd Bld St1-4
D5	2871	Sd Blues St1-3
D#5	2894	Sd BluesHeart R1-3
E5	2921	Sd Hip St1-2
F5	2798	Sd Normal St1-4
F#5	3169	Sd LdwHMMono
G5	2739	Sd Soul St1-3
G#5	3172	Sd Heavy
A5	2822	Sd Funk 1St
A#5	2488	Bd Normal 1St
B5	2517	Bd Funk Son St
C6	2460	Bd Snap 1-2

PDR 4 Dry Standard Kit

Note	Wave Number	Wave Name
C0	2106	Claves1
C#0	3205	Sd Brush Soft St
D0	3217	Sd Brush Swir St
D#0	3208	Sd Brush Med St
E0	3220	Sd Brush SwirAtt St
F0	3201	Sd LiveRoll St
F#0	1935	Castanet1
G0	2804	Sd Normal 1St
G#0	1933	Stick1
A0	2496	Bd Funk St1-2
A#0	2838	Sd Basic St2-3
B0	2505	Bd High St
C1	2487	Bd Normal St1-2
C#1	3190	Sd Closed Rim St
D1	2798	Sd Normal St1-4
D#1	2423	Clap T9
E1	2837	Sd Basic St1-2
F1	3651	Tom Floor St
F#1	3372	HH Closed 1-4St
G1	3651	Tom Floor St
G#1	3395	HH Pedal 3 St
A1	3647	Tom Low St
A#1	3408	HH Open 1-2St
B1	3647	Tom Low St
C2	3643	Tom Mid St
C#2	3870	Crash2 RL
D2	3639	Tom Hi St
D#2	3907	Ride1 St
E2	3954	China1 St
F2	3935	Ride Cup1 St
F#2	1927	Tambourine1 Sw
G2	3963	Splash1 St
G#2	2110	Cowbell2
A2	3870	Crash2 RL
A#2	1940	Vibraslap1
B2	3910	Ride1 RL
C3	2007	Bongo1 Hi 1Fingr 1-2
C#3	2020	Bongo1 Lo 3Fingr 1-2
D3	1972	Conga1 Hi Slap Open
D#3	1970	Conga1 Hi Open 2
E3	2001	Tumba Open
F3	2033	Timbale1 Hi 1-3
F#3	2037	Timbale1 Lo 1-2
G3	2080	Agogo Hi
G#3	2081	Agogo Lo
A3	2059	CabasaA 1-2
A#3	2057	Maracas Slur
B3	2108	Whistle
C4	2108	Whistle
C#4	2084	Guiro Short
D4	2083	Guiro Long
D#4	2106	Claves1
E4	1939	Wood Block
F4	1939	Wood Block
F#4	2006	Cuica Hi
G4	2005	Cuica Lo
G#4	1944	Triangle Mute
A4	1943	Triangle Open
A#4	1917	ShakerA 1
B4	1954	Sleigh Bell1
C5	1957	Wind Chime
C#5	2718	Sd Bld St1-4
D5	2878	Sd Blues L1-3
D#5	2921	Sd Hip St1-2
E5	2818	Sd Funk St1-3
F5	2740	Sd Soul St2-4
F#5	3169	Sd LdwHMMono
G5	3172	Sd Heavy
G#5	2901	Sd Tight St1-4
A5	2889	Sd BluesHeart St1/3
A#5	2460	Bd Snap 1-2
B5	2469	Bd Tight 1-2
C6	2496	Bd Funk St1-2

PDR 5 Modern Rock Kit

Note	Wave Number	Wave Name
C0	2106	Claves1
C#0	3205	Sd Brush Soft St
D0	3217	Sd Brush Swir St
D#0	3208	Sd Brush Med St
E0	3220	Sd Brush SwirAtt St
F0	3201	Sd LiveRoll St
F#0	1935	Castanet1
G0	2932	Sd Rock Open1 R
G#0	1933	Stick1
A0	2531	Bd Room1
A#0	2787	Sd Rng St4
B0	2540	Bd Jazz2St
C1	2533	Bd Room3
C#1	3177	Sd Rock Stick2 St
D1	2758	Sd Strong St1-4
D#1	2447	HipHop Clap6
E1	2957	Sd PowerA 1-5St
F1	3651	Tom Floor St
F#1	3432	HH Closed Rock Sw St
G1	3647	Tom Low St
G#1	3460	HH Half Open Rock St
A1	3647	Tom Low St
A#1	3458	HH Open Rock St
B1	3643	Tom Mid St
C2	3643	Tom Mid St
C#2	3866	Crash1 RL
D2	3639	Tom Hi St
D#2	3911	Ride2 St
E2	3954	China1 St
F2	3947	Ride Cup2 St
F#2	1927	Tambourine1 Sw
G2	3963	Splash1 St
G#2	2110	Cowbell2
A2	3863	Crash1 St
A#2	1940	Vibraslap1
B2	3938	Ride Cup1 RL
C3	2007	Bongo1 Hi 1Fingr 1-2
C#3	2020	Bongo1 Lo 3Fingr 1-2
D3	1966	Conga1 Hi Tip
D#3	1970	Conga1 Hi Open 2
E3	2001	Tumba Open
F3	2033	Timbale1 Hi 1-3
F#3	2037	Timbale1 Lo 1-2
G3	2080	Agogo Hi
G#3	2081	Agogo Lo
A3	2059	CabasaA 1-2
A#3	2057	Maracas Slur
B3	2108	Whistle
C4	2108	Whistle
C#4	2084	Guiro Short
D4	2083	Guiro Long
D#4	2106	Claves1
E4	1939	Wood Block
F4	1939	Wood Block
F#4	2006	Cuica Hi
G4	2005	Cuica Lo
G#4	1944	Triangle Mute
A4	1943	Triangle Open
A#4	1917	ShakerA 1
B4	1954	Sleigh Bell1
C5	1957	Wind Chime
C#5	2874	Sd Blues St1/3
D5	2901	Sd Tight St1-4
D#5	2894	Sd BluesHeart R1-3
E5	2912	Sd Tight R1-4
F5	2508	Bd Low St
F#5	3017	Sd PowerC 4St
G5	2666	Bd R&B1
G#5	2978	Sd PowerB 1-5St
A5	2531	Bd Room1
A#5	2957	Sd PowerA 1-5St
B5	2517	Bd Funk Son St
C6	2532	Bd Room2

PDR 6 Rock Stereo Kit 1

Note	Wave Number	Wave Name
C0	2441	Analog Click
C#0	3205	Sd Brush Soft St
D0	3217	Sd Brush Swir St
D#0	3208	Sd Brush Med St
E0	3220	Sd Brush SwirAtt St
F0	3195	Sd RockRoll St
F#0	1935	Castanet1
G0	2939	Sd Rock Open2 St
G#0	1933	Stick1
A0	2533	Bd Room3
A#0	2936	Sd Rock Rim1 St
B0	2523	Bd Rock2 St
C1	2520	Bd Rock1 St
C#1	3174	Sd Rock Stick1 St
D1	2930	Sd Rock Open1 St
D#1	2444	HipHop Clap3
E1	2933	Sd Rock Mute1 St
F1	3663	Tom Rock Low St
F#1	3432	HH Closed Rock Sw St
G1	3663	Tom Rock Low St
G#1	3444	HH Pedal Rock Sw St
A1	3659	Tom Rock Mid St
A#1	3456	HH Open Rock Sw St
B1	3659	Tom Rock Mid St
C2	3655	Tom Rock Hi St
C#2	3866	Crash1 RL
D2	3655	Tom Rock Hi St
D#2	3911	Ride2 St
E2	3954	China1 St
F2	3947	Ride Cup2 St
F#2	2433	Tambourine RX5
G2	3963	Splash1 St
G#2	2109	Cowbell1
A2	3863	Crash1 St
A#2	1940	Vibraslap1
B2	3914	Ride2 RL
C3	2007	Bongo1 Hi 1Fingr 1-2
C#3	2020	Bongo1 Lo 3Fingr 1-2
D3	1966	Conga1 Hi Tip
D#3	1970	Conga1 Hi Open 2
E3	2001	Tumba Open
F3	2033	Timbale1 Hi 1-3
F#3	2037	Timbale1 Lo 1-2
G3	2080	Agogo Hi
G#3	2081	Agogo Lo
A3	2059	CabasaA 1-2
A#3	2057	Maracas Slur
B3	2108	Whistle
C4	2108	Whistle
C#4	2084	Guiro Short
D4	2083	Guiro Long
D#4	2106	Claves1
E4	1939	Wood Block
F4	1939	Wood Block
F#4	2006	Cuica Hi
G4	2005	Cuica Lo
G#4	1944	Triangle Mute
A4	1943	Triangle Open
A#4	1917	ShakerA 1
B4	1954	Sleigh Bell1
C5	1957	Wind Chime
C#5	2948	Sd Rock Flam St
D5	2939	Sd Rock Open2 St
D#5	2945	Sd Rock Rim2 St
E5	2942	Sd Rock Mute2 St
F5	2497	Bd Funk 1St
F#5	3198	Sd RockRollID St
G5	2511	Bd H Son St
G#5	2901	Sd Tight St1-4
A5	2517	Bd Funk Son St
A#5	2859	Sd SonA 3St
B5	2500	Bd Funk R1-2
C6	2511	Bd H Son St

PDR 7 Rock Stereo Kit 2

Note	Wave Number	Wave Name
C0	2441	Analog Click
C#0	3205	Sd Brush Soft St
D0	3217	Sd Brush Swir St
D#0	3208	Sd Brush Med St
E0	3220	Sd Brush SwirAtt St
F0	3195	Sd RockRoll St
F#0	1935	Castanet1
G0	2939	Sd Rock Open2 St
G#0	1933	Stick1
A0	2531	Bd Room1
A#0	2945	Sd Rock Rim2 St
B0	2481	Bd Ambience L1-2
C1	2523	Bd Rock2 St
C#1	3177	Sd Rock Stick2 St
D1	2939	Sd Rock Open2 St
D#1	1945	Hand Clap1 St
E1	2942	Sd Rock Mute2 St
F1	3663	Tom Rock Low St
F#1	3448	HH Closed Rock 2St
G1	3663	Tom Rock Low St
G#1	3460	HH Half Open Rock St
A1	3659	Tom Rock Mid St
A#1	3458	HH Open Rock St
B1	3659	Tom Rock Mid St
C2	3655	Tom Rock Hi St
C#2	3867	Crash2 St
D2	3655	Tom Rock Hi St
D#2	3911	Ride2 St
E2	3954	China1 St
F2	3947	Ride Cup2 St
F#2	2433	Tambourine RX5
G2	3963	Splash1 St
G#2	2109	Cowbell1
A2	3870	Crash2 RL
A#2	1940	Vibraslap1
B2	3914	Ride2 RL
C3	2007	Bongo1 Hi 1Fingr 1-2
C#3	2020	Bongo1 Lo 3Fingr 1-2
D3	1966	Conga1 Hi Tip
D#3	1970	Conga1 Hi Open 2
E3	2001	Tumba Open
F3	2033	Timbale1 Hi 1-3
F#3	2037	Timbale1 Lo 1-2
G3	2080	Agogo Hi
G#3	2081	Agogo Lo
A3	2059	CabasaA 1-2
A#3	2057	Maracas Slur
B3	2108	Whistle
C4	2108	Whistle
C#4	2084	Guiro Short
D4	2083	Guiro Long
D#4	2106	Claves1
E4	1939	Wood Block
F4	1939	Wood Block
F#4	2006	Cuica Hi
G4	2005	Cuica Lo
G#4	1944	Triangle Mute
A4	1943	Triangle Open
A#4	1917	ShakerA 1
B4	1954	Sleigh Bell1
C5	1957	Wind Chime
C#5	2948	Sd Rock Flam St
D5	2930	Sd Rock Open1 St
D#5	2936	Sd Rock Rim1 St
E5	2933	Sd Rock Mute1 St
F5	2520	Bd Rock1 St
F#5	3198	Sd RockRollID St
G5	2498	Bd Funk 2St
G#5	2901	Sd Tight St1-4
A5	2505	Bd High St
A#5	2860	Sd SonA 4St
B5	2514	Bd L Son St
C6	2520	Bd Rock1 St

PDR 8 Nu Hip Hop Kit 1

Note	Wave Number	Wave Name
C0	2706	Bd HipHop2
C#0	2061	CabasaA 2
D0	3356	Sd HipHop9
D#0	1754	Scratch Lo R
E0	1759	Scratch Vo F
F0	3198	Sd RockRollID St
F#0	2106	Claves1
G0	3353	Sd HipHop5
G#0	3368	Sd HipHop Rim3
A0	2712	Bd HipHop8
A#0	3371	Sd HipHop Rim6
B0	2713	Bd HipHop9
C1	2709	Bd HipHop5
C#1	3367	Sd HipHop Rim2
D1	3358	Sd HipHop11
D#1	2443	HipHop Clap2
E1	3351	Sd HipHop2
F1	3652	Tom Floor L
F#1	3629	HH Closed Hip
G1	3648	Tom Low L
G#1	3630	HH Pedal Hip
A1	3645	Tom Mid R
A#1	3631	HH Open Hip
B1	3641	Tom Hi R
C2	3641	Tom Hi R
C#2	3872	Crash4
D2	3641	Tom Hi R
D#2	3912	Ride2 L
E2	3868	Crash2 L
F2	3951	Ride Mono
F#2	1929	Tambourine1 Hit
G2	3902	Hand Cymbal Open L
G#2	2117	Mambo Bell Body
A2	3956	China1 R
A#2	1952	Handbell L
B2	3953	Ride Cup Mono2
C3	1972	Conga1 Hi Slap Open
C#3	1980	Conga1 Lo Open 1
D3	1977	Conga1 Lo Tip
D#3	1983	Conga1 Lo Slap Open
E3	1981	Conga1 Lo Open 2
F3	2708	Bd HipHop4
F#3	2444	HipHop Clap3
G3	2080	Agogo Hi
G#3	2081	Agogo Lo
A3	1918	ShakerA 2
A#3	1917	ShakerA 1
B3	2714	Bd HipHop10
C4	2710	Bd HipHop6
C#4	3369	Sd HipHop Rim4
D4	3354	Sd HipHop6
D#4	2458	HipHop Snap1
E4	2714	Bd HipHop10
F4	3355	Sd HipHop7
F#4	2442	HipHop Clap1
G4	2051	Paila L
G#4	1944	Triangle Mute
A4	1943	Triangle Open
A#4	1927	Tambourine1 Sw
B4	1918	ShakerA 2
C5	2712	Bd HipHop8
C#5	2423	Clap T9
D5	3293	Sd T8-1
D#5	3293	Sd T8-1
E5	3296	Sd T8-4
F5	3856	Tom T8
F#5	3614	HH Closed T8-2
G5	3856	Tom T8
G#5	3614	HH Closed T8-2
A5	3856	Tom T8
A#5	3615	HH Open T8-2
B5	3856	Tom T8
C6	3972	Crash T8

PDR 9 Nu Hip Hop Kit 2

Note	Wave Number	Wave Name
C0	2707	Bd HipHop3
C#0	1727	Hi Q2
D0	1764	Scratch Hip2
D#0	1758	Scratch Sd R
E0	1760	Scratch Vo R
F0	3331	Sd Break Roll
F#0	3292	Sd T9Rim
G0	3351	Sd HipHop2
G#0	3298	Sd T8 Rim
A0	2713	Bd HipHop9
A#0	3366	Sd HipHop Rim1
B0	2710	Bd HipHop6
C1	2709	Bd HipHop5
C#1	3367	Sd HipHop Rim2
D1	3350	Sd HipHop1
D#1	2447	HipHop Clap6
E1	3356	Sd HipHop9
F1	3855	Tom T9 Lo
F#1	3629	HH Closed Hip
G1	3855	Tom T9 Lo
G#1	3630	HH Pedal Hip
A1	3854	Tom T9 Hi
A#1	3631	HH Open Hip
B1	3854	Tom T9 Hi
C2	3856	Tom T8
C#2	3871	Crash3
D2	3856	Tom T8
D#2	3975	Ride T9
E2	3975	Ride T9
F2	3893	Crash Brush Cup St
F#2	2433	Tambourine RX5
G2	3973	Crash Syn
G#2	2430	Cowbell AnCR
A2	3971	Crash T9
A#2	2089	MetalGuero Long
B2	3951	Ride Mono
C3	2096	Cajon1 Tip 1-2
C#3	2024	Bongo1 Lo Tip
D3	2078	Tmbourim Finger
D#3	2071	Tumbo 2
E3	2004	Tumba Heel
F3	2052	Paila H
F#3	2051	Paila L
G3	2428	Cowbell T8
G#3	2430	Cowbell AnCR
A3	2153	Shekere Up
A#3	2068	Caxixi 1
B3	1683	Grain2 St
C4	1684	Grain2 L
C#4	2097	Cajon1 Tip 1
D4	2448	HipHop Clap7
D#4	2106	Claves1
E4	1939	Wood Block
F4	3369	Sd HipHop Rim4
F#4	2458	HipHop Snap1
G4	2459	HipHop Snap2
G#4	2440	Electric Triangle
A4	1943	Triangle Open
A#4	1917	ShakerA 1
B4	2089	MetalGuero Long
C5	1957	Wind Chime
C#5	3369	Sd HipHop Rim4
D5	3293	Sd T8-1
D#5	3294	Sd T8-2
E5	3296	Sd T8-4
F5	3856	Tom T8
F#5	3614	HH Closed T8-2
G5	3856	Tom T8
G#5	3614	HH Closed T8-2
A5	3856	Tom T8
A#5	3615	HH Open T8-2
B5	3856	Tom T8
C6	2456	HipHop Flex1

PDR 10 Hip Hop Kit 1

Note	Wave Number	Wave Name
C0	3181	Sd Hip Stick2
C#0	1728	Vox Hit Rev
D0	1735	TurnTable
D#0	1598	Hit Brass
E0	1758	Scratch Sd R
F0	3203	Sd LiveRoll R
F#0	2439	Claves T8
G0	2929	Sd Hip 2R
G#0	3187	Sd Hip Stick6 R
A0	2713	Bd HipHop9
A#0	3340	Sd Garg L
B0	2653	Bd T8-3
C1	2644	Bd T9-1
C#1	3368	Sd HipHop Rim3
D1	3357	Sd HipHop10
D#1	2447	HipHop Clap6
E1	3350	Sd HipHop1
F1	3856	Tom T8
F#1	3612	HH Closed T8-1
G1	3856	Tom T8
G#1	3613	HH Open T8-1
A1	3856	Tom T8
A#1	3613	HH Open T8-1
B1	3856	Tom T8
C2	3856	Tom T8
C#2	3872	Crash4
D2	3856	Tom T8
D#2	3941	Ride Brush1 R
E2	3972	Crash T8
F2	3975	Ride T9
F#2	2433	Tambourine RX5
G2	3965	Splash1 R
G#2	2117	Mambo Bell Body
A2	3971	Crash T9
A#2	1940	Vibraslap1
B2	3975	Ride T9
C3	2007	Bongo1 Hi 1Fingr 1-2
C#3	2020	Bongo1 Lo 3Fingr 1-2
D3	1966	Conga1 Hi Tip
D#3	1970	Conga1 Hi Open 2
E3	2001	Tumba Open
F3	2033	Timbale1 Hi 1-3
F#3	2037	Timbale1 Lo 1-2
G3	2080	Agogo Hi
G#3	2081	Agogo Lo
A3	2059	CabasaA 1-2
A#3	2057	Maracas Slur
B3	2108	Whistle
C4	2108	Whistle
C#4	2084	Guero Short
D4	2083	Guero Long
D#4	2106	Claves1
E4	1939	Wood Block
F4	1939	Wood Block
F#4	2006	Cuica Hi
G4	2005	Cuica Lo
G#4	1944	Triangle Mute
A4	1943	Triangle Open
A#4	1917	ShakerA 1
B4	1954	Sleigh Bell1
C5	1957	Wind Chime
C#5	3189	Sd Hip Stick8
D5	3309	Sd Jungle3
D#5	1947	Hand Clap1 R
E5	3326	Sd Hip Rim5
F5	1748	Scratch H
F#5	1749	Scratch L
G5	1750	Scratch Down
G#5	1752	Scratch Hi R
A5	1755	Scratch Bd F
A#5	1767	Scratch Combi
B5	1760	Scratch Vo R
C6	2671	Bd Break2

PDR 11 Hip Hop Kit 2

Note	Wave Number	Wave Name
C0	2653	Bd T8-3
C#0	3298	Sd T8 Rim
D0	3318	Sd Hip1
D#0	2423	Clap T9
E0	3343	Sd Syn
F0	3203	Sd LiveRoll R
F#0	3183	Sd Hip Stick4
G0	3351	Sd HipHop2
G#0	3371	Sd HipHop Rim6
A0	2668	Bd Hip Deep
A#0	3316	Sd R&B1 Rim
B0	2672	Bd Break Heavy
C1	2668	Bd Hip Deep
C#1	3367	Sd HipHop Rim2
D1	3320	Sd Hip3
D#1	1945	Hand Clap1 St
E1	3348	Sd Lo-Fi
F1	3653	Tom Floor R
F#1	3632	HH Closed Lo-Fi
G1	3648	Tom Low L
G#1	3621	HH Closed Break
A1	3648	Tom Low L
A#1	3633	HH Open Lo-Fi
B1	3648	Tom Low L
C2	3640	Tom Hi L
C#2	3871	Crash3
D2	3640	Tom Hi L
D#2	3975	Ride T9
E2	3958	China2
F2	3952	Ride Cup Mono
F#2	2433	Tambourine RX5
G2	3871	Crash3
G#2	2429	Cowbell RX11
A2	3869	Crash2 R
A#2	2428	Cowbell T8
B2	3975	Ride T9
C3	2007	Bongo1 Hi 1Fingr 1-2
C#3	2020	Bongo1 Lo 3Fingr 1-2
D3	1966	Conga1 Hi Tip
D#3	1972	Conga1 Hi Slap Open
E3	1970	Conga1 Hi Open 2
F3	1659	Radio Noise
F#3	1659	Radio Noise
G3	2081	Agogo Lo
G#3	2081	Agogo Lo
A3	2060	CabasaA 1
A#3	2437	MaracasT8
B3	1732	FxGun2
C4	1731	FxGun1
C#4	1762	Scratch Spin
D4	1761	Scratch Stop
D#4	2439	Claves T8
E4	1737	Door Squeak
F4	1727	Hi Q2
F#4	1755	Scratch Bd F
G4	1756	Scratch Bd R
G#4	1944	Triangle Mute
A4	1943	Triangle Open
A#4	2432	Analog Shaker
B4	1929	Tambourine1 Hit
C5	1957	Wind Chime
C#5	3306	Sd Human2
D5	3331	Sd Break Roll
D#5	1601	Stab Hard
E5	3307	Sd Jungle1
F5	2520	Bd Rock1 St
F#5	1750	Scratch Down
G5	2178	Wa Taiko
G#5	1596	HH Hit
A5	1602	Stab Organ2
A#5	1554	Sonar1
B5	1735	TurnTable
C6	1736	Police

PDR 12 Hip Hop Kit 3

Note	Wave Number	Wave Name
C0	3298	Sd T8 Rim
C#0	1728	Vox Hit Rev
D0	1735	TurnTable
D#0	1601	Stab Hard
E0	1760	Scratch Vo R
F0	3204	Sd Roll Mono
F#0	2439	Claves T8
G0	2927	Sd Hip 1R
G#0	3183	Sd Hip Stick4
A0	2655	Bd AnCR
A#0	3324	Sd Hip Rim3
B0	2646	Bd T9-3
C1	2668	Bd Hip Deep
C#1	3184	Sd Hip Stick5
D1	3321	Sd Hip Gate
D#1	2447	HipHop Clap6
E1	3348	Sd Lo-Fi
F1	3856	Tom T8
F#1	3629	HH Closed Hip
G1	3856	Tom T8
G#1	3630	HH Pedal Hip
A1	3856	Tom T8
A#1	3631	HH Open Hip
B1	3856	Tom T8
C2	3856	Tom T8
C#2	3872	Crash4
D2	3856	Tom T8
D#2	3913	Ride2 R
E2	3972	Crash T8
F2	3975	Ride T9
F#2	2433	Tambourine RX5
G2	3965	Splash1 R
G#2	2117	Mambo Bell Body
A2	3971	Crash T9
A#2	1940	Vibraslap1
B2	3975	Ride T9
C3	2007	Bongo1 Hi 1Fingr 1-2
C#3	2020	Bongo1 Lo 3Fingr 1-2
D3	1966	Conga1 Hi Tip
D#3	1972	Conga1 Hi Slap Open
E3	1970	Conga1 Hi Open 2
F3	2033	Timbale1 Hi 1-3
F#3	2037	Timbale1 Lo 1-2
G3	2080	Agogo Hi
G#3	2081	Agogo Lo
A3	1923	Shaker Hip1
A#3	2057	Maracas Slur
B3	2108	Whistle
C4	2108	Whistle
C#4	2084	Guero Short
D4	2083	Guero Long
D#4	2106	Claves1
E4	1939	Wood Block
F4	1939	Wood Block
F#4	2006	Cuica Hi
G4	2005	Cuica Lo
G#4	1944	Triangle Mute
A4	1943	Triangle Open
A#4	1917	ShakerA 1
B4	1954	Sleigh Bell1
C5	1957	Wind Chime
C#5	3180	Sd Hip Stick1
D5	3307	Sd Jungle1
D#5	1947	Hand Clap1 R
E5	3330	Sd Break Heavy
F5	1749	Scratch L
F#5	1750	Scratch Down
G5	1751	Scratch Hi F
G#5	1753	Scratch Lo F
A5	1754	Scratch Lo R
A#5	1755	Scratch Bd F
B5	1756	Scratch Bd R
C6	2672	Bd Break Heavy

PDR 13 Hip Hop Kit 4

Note	Wave Number	Wave Name
C0	3180	Sd Hip Stick1
C#0	1726	Hi Q1
D0	1735	TurnTable
D#0	1604	Hit Uhh
E0	1761	Scratch Stop
F0	3202	Sd LiveRoll L
F#0	2439	Claves T8
G0	3338	Sd Cut
G#0	3176	Sd Rock Stick1 R
A0	2645	Bd T9-2
A#0	3322	Sd Hip Rim1
B0	2667	Bd R&B2
C1	2669	Bd Break Deep
C#1	3194	Sd Closed Rim3
D1	3323	Sd Hip Rim2
D#1	2445	HipHop Clap4
E1	3315	Sd R&B1
F1	2427	Conga T8
F#1	3612	HH Closed T8-1
G1	2427	Conga T8
G#1	3614	HH Closed T8-2
A1	2427	Conga T8
A#1	3615	HH Open T8-2
B1	2427	Conga T8
C2	2427	Conga T8
C#2	3872	Crash4
D2	2427	Conga T8
D#2	3913	Ride2 R
E2	3972	Crash T8
F2	3975	Ride T9
F#2	2433	Tambourine RX5
G2	3965	Splash1 R
G#2	2117	Mambo Bell Body
A2	3971	Crash T9
A#2	1940	Vibraslap1
B2	3975	Ride T9
C3	2007	Bongo1 Hi 1Fingr 1-2
C#3	2020	Bongo1 Lo 3Fingr 1-2
D3	1966	Conga1 Hi Tip
D#3	1970	Conga1 Hi Open 2
E3	2001	Tumba Open
F3	2033	Timbale1 Hi 1-3
F#3	2037	Timbale1 Lo 1-2
G3	2080	Agogo Hi
G#3	2081	Agogo Lo
A3	2059	CabasaA 1-2
A#3	2057	Maracas Slur
B3	2108	Whistle
C4	2108	Whistle
C#4	2084	Guiro Short
D4	2083	Guiro Long
D#4	2106	Claves1
E4	1939	Wood Block
F4	1939	Wood Block
F#4	2006	Cuica Hi
G4	2005	Cuica Lo
G#4	1944	Triangle Mute
A4	1943	Triangle Open
A#4	1917	ShakerA 1
B4	1954	Sleigh Bell1
C5	1957	Wind Chime
C#5	3192	Sd Closed Rim R
D5	3302	Sd AnSm Rim
D#5	1945	Hand Clap1 St
E5	3320	Sd Hip3
F5	1758	Scratch Sd R
F#5	1763	Scratch Hip
G5	1756	Scratch Bd R
G#5	1760	Scratch Vo R
A5	1764	Scratch Hip2
A#5	1768	Scratch Combi2
B5	1770	Scratch Combi4
C6	2668	Bd Hip Deep

PDR 14 Hip Stick Kit 1

Note	Wave Number	Wave Name
C0	3325	Sd Hip Rim4
C#0	1726	Hi Q1
D0	1735	TurnTable
D#0	1597	Hit Orchestra1
E0	1756	Scratch Bd R
F0	3203	Sd LiveRoll R
F#0	2441	Analog Click
G0	3324	Sd Hip Rim3
G#0	3304	Sd AnCR Rim
A0	2713	Bd HipHop9
A#0	3371	Sd HipHop Rim6
B0	2653	Bd T8-3
C1	2652	Bd T8-2
C#1	3298	Sd T8 Rim
D1	3183	Sd Hip Stick4
D#1	1947	Hand Clap1 R
E1	3182	Sd Hip Stick3
F1	3856	Tom T8
F#1	3612	HH Closed T8-1
G1	3856	Tom T8
G#1	3613	HH Open T8-1
A1	3856	Tom T8
A#1	3613	HH Open T8-1
B1	3856	Tom T8
C2	3856	Tom T8
C#2	3872	Crash4
D2	3856	Tom T8
D#2	3913	Ride2 R
E2	3972	Crash T8
F2	3975	Ride T9
F#2	2433	Tambourine RX5
G2	3965	Splash1 R
G#2	2117	Mambo Bell Body
A2	3971	Crash T9
A#2	1940	Vibraslap1
B2	3975	Ride T9
C3	2007	Bongo1 Hi 1Fingr 1-2
C#3	2020	Bongo1 Lo 3Fingr 1-2
D3	1966	Conga1 Hi Tip
D#3	1970	Conga1 Hi Open 2
E3	2001	Tumba Open
F3	2033	Timbale1 Hi 1-3
F#3	2037	Timbale1 Lo 1-2
G3	2080	Agogo Hi
G#3	2081	Agogo Lo
A3	2059	CabasaA 1-2
A#3	2057	Maracas Slur
B3	2108	Whistle
C4	2108	Whistle
C#4	2084	Guiro Short
D4	2083	Guiro Long
D#4	2106	Claves1
E4	1939	Wood Block
F4	1939	Wood Block
F#4	2006	Cuica Hi
G4	2005	Cuica Lo
G#4	1944	Triangle Mute
A4	1943	Triangle Open
A#4	1917	ShakerA 1
B4	1954	Sleigh Bell1
C5	1957	Wind Chime
C#5	3301	Sd AnSm
D5	3194	Sd Closed Rim3
D#5	2441	Analog Click
E5	3193	Sd Closed Rim2
F5	1748	Scratch H
F#5	1749	Scratch L
G5	1750	Scratch Down
G#5	1752	Scratch Hi R
A5	1755	Scratch Bd F
A#5	1767	Scratch Combi
B5	1760	Scratch Vo R
C6	2662	Bd Jungle2

PDR 15 Hip Stick Kit 2

Note	Wave Number	Wave Name
C0	3324	Sd Hip Rim3
C#0	1727	Hi Q2
D0	1748	Scratch H
D#0	1748	Scratch H
E0	1760	Scratch Vo R
F0	3204	Sd Roll Mono
F#0	2441	Analog Click
G0	3325	Sd Hip Rim4
G#0	3298	Sd T8 Rim
A0	2713	Bd HipHop9
A#0	3183	Sd Hip Stick4
B0	2686	Bd Hard Long
C1	2702	Bd ElecClick
C#1	3180	Sd Hip Stick1
D1	3181	Sd Hip Stick2
D#1	2449	HipHop Clap8
E1	3185	Sd Hip Stick6 St
F1	3855	Tom T9 Lo
F#1	3612	HH Closed T8-1
G1	3855	Tom T9 Lo
G#1	3613	HH Open T8-1
A1	3855	Tom T9 Lo
A#1	3613	HH Open T8-1
B1	3855	Tom T9 Lo
C2	3855	Tom T9 Lo
C#2	3971	Crash T9
D2	3855	Tom T9 Lo
D#2	3910	Ride1 RL
E2	3972	Crash T8
F2	3953	Ride Cup Mono2
F#2	2436	Electric Tambourine2
G2	3965	Splash1 R
G#2	2428	Cowbell T8
A2	3971	Crash T9
A#2	1940	Vibraslap1
B2	3973	Crash Syn
C3	2007	Bongo1 Hi 1Fingr 1-2
C#3	2020	Bongo1 Lo 3Fingr 1-2
D3	1966	Conga1 Hi Tip
D#3	1970	Conga1 Hi Open 2
E3	2001	Tumba Open
F3	2033	Timbale1 Hi 1-3
F#3	2037	Timbale1 Lo 1-2
G3	2080	Agogo Hi
G#3	2081	Agogo Lo
A3	2059	CabasaA 1-2
A#3	2057	Maracas Slur
B3	2108	Whistle
C4	2108	Whistle
C#4	2084	Guiro Short
D4	2083	Guiro Long
D#4	2106	Claves1
E4	1939	Wood Block
F4	1939	Wood Block
F#4	2006	Cuica Hi
G4	2005	Cuica Lo
G#4	1944	Triangle Mute
A4	1943	Triangle Open
A#4	1917	ShakerA 1
B4	1954	Sleigh Bell1
C5	1957	Wind Chime
C#5	3298	Sd T8 Rim
D5	3180	Sd Hip Stick1
D#5	3181	Sd Hip Stick2
E5	3193	Sd Closed Rim2
F5	1750	Scratch Down
F#5	1751	Scratch Hi F
G5	1753	Scratch Lo F
G#5	1754	Scratch Lo R
A5	1756	Scratch Bd R
A#5	1767	Scratch Combi
B5	1761	Scratch Stop
C6	2712	Bd HipHop8

PDR 16 R&B Kit 1

Note	Wave Number	Wave Name
C0	2650	Bd T9 Hd3
C#0	3303	Sd AnCR
D0	3302	Sd AnSm Rim
D#0	3336	Sd ClapAna
E0	3291	Sd T9Gate
F0	3204	Sd Roll Mono
F#0	3345	Sd Timbr
G0	3342	Sd FM Rim
G#0	3310	Sd JungleFX
A0	2647	Bd T9-4
A#0	3326	Sd Hip Rim5
B0	2646	Bd T9-3
C1	2693	Bd Elec2
C#1	3298	Sd T8 Rim
D1	3348	Sd Lo-Fi
D#1	2443	HipHop Clap2
E1	3315	Sd R&B1
F1	2653	Bd T8-3
F#1	3610	HH Closed T9
G1	2653	Bd T8-3
G#1	3630	HH Pedal Hip
A1	2653	Bd T8-3
A#1	3611	HH Open T9
B1	2653	Bd T8-3
C2	2653	Bd T8-3
C#2	3866	Crash1 RL
D2	2653	Bd T8-3
D#2	3911	Ride2 St
E2	3958	China2
F2	3952	Ride Cup Mono
F#2	1929	Tambourine 1 Hit
G2	3871	Crash3
G#2	2109	Cowbell1
A2	3863	Crash1 St
A#2	2428	Cowbell T8
B2	3907	Ride1 St
C3	2007	Bongo1 Hi 1Fingr 1-2
C#3	2020	Bongo1 Lo 3Fingr 1-2
D3	1966	Conga1 Hi Tip
D#3	1972	Conga1 Hi Slap Open
E3	1970	Conga1 Hi Open 2
F3	1726	Hi Q1
F#3	1726	Hi Q1
G3	2081	Agogo Lo
G#3	2081	Agogo Lo
A3	2432	Analog Shaker
A#3	2057	Maracas Slur
B3	1606	Vox Drum
C4	1606	Vox Drum
C#4	1726	Hi Q1
D4	1727	Hi Q2
D#4	2439	Conga1 Hi Slap Open
E4	1726	Hi Q1
F4	1762	Scratch Spin
F#4	1752	Scratch Hi R
G4	1751	Scratch Hi F
G#4	1944	Triangle Mute
A4	1943	Triangle Open
A#4	1918	ShakerA 2
B4	1929	Tambourine 1 Hit
C5	1957	Wind Chime
C#5	3331	Sd Break Roll
D5	1708	Noise Burst
D#5	1539	Vox Bell
E5	3315	Sd R&B1
F5	1545	VoxAlk
F#5	2220	Udu High
G5	1543	Trance Choir
G#5	1734	Swarm
A5	2528	Bd Pop
A#5	3316	Sd R&B1 Rim
B5	2667	Bd R&B2
C6	3871	Crash3

PDR 17 R&B Kit 2

Note	Wave Number	Wave Name
C0	2644	Bd T9-1
C#0	3304	Sd AnCR Rim
D0	3321	Sd Hip Gate
D#0	3331	Sd Break Roll
E0	3287	Sd T9-2
F0	3201	Sd LiveRoll St
F#0	2459	HipHop Snap2
G0	3356	Sd HipHop9
G#0	3367	Sd HipHop Rim2
A0	2709	Bd HipHop5
A#0	3325	Sd Hip Rim4
B0	2644	Bd T9-1
C1	2652	Bd T8-2
C#1	3366	Sd HipHop Rim1
D1	2459	HipHop Snap2
D#1	2449	HipHop Clap8
E1	3297	Sd T8-5
F1	3856	Tom T8
F#1	3612	HH Closed T8-1
G1	3856	Tom T8
G#1	3613	HH Open T8-1
A1	3856	Tom T8
A#1	3613	HH Open T8-1
B1	3856	Tom T8
C2	3856	Tom T8
C#2	3866	Crash1 RL
D2	3856	Tom T8
D#2	3911	Ride2 St
E2	3958	China2
F2	3952	Ride Cup Mono
F#2	1929	Tambourine1 Hit
G2	3871	Crash3
G#2	2109	Cowbell1
A2	3863	Crash1 St
A#2	2428	Cowbell T8
B2	3907	Ride1 St
C3	2007	Bongo1 Hi 1Fingr 1-2
C#3	2020	Bongo1 Lo 3Fingr 1-2
D3	1966	Conga1 Hi Tip
D#3	1972	Conga1 Hi Slap Open
E3	1970	Conga1 Hi Open 2
F3	1726	Hi Q1
F#3	1726	Hi Q1
G3	2081	Agogo Lo
G#3	2081	Agogo Lo
A3	2432	Analog Shaker
A#3	2057	Maracas Slur
B3	1606	Vox Drum
C4	1606	Vox Drum
C#4	1726	Hi Q1
D4	1727	Hi Q2
D#4	2439	Claves T8
E4	1726	Hi Q1
F4	1762	Scratch Spin
F#4	1752	Scratch Hi R
G4	1751	Scratch Hi F
G#4	1944	Triangle Mute
A4	1943	Triangle Open
A#4	1918	ShakerA 2
B4	1929	Tambourine1 Hit
C5	1957	Wind Chime
C#5	3331	Sd Break Roll
D5	1708	Noise Burst
D#5	1539	Vox Bell
E5	3315	Sd R&B1
F5	1545	VoxAlk
F#5	2220	Udu High
G5	1543	Trance Choir
G#5	1734	Swarm
A5	2528	Bd Pop
A#5	3316	Sd R&B1 Rim
B5	2667	Bd R&B2
C6	3871	Crash3

PDR 18 R&B Kit 3

Note	Wave Number	Wave Name
C0	2649	Bd T9 Hd2
C#0	3303	Sd AnCR
D0	3328	Sd Break2
D#0	3331	Sd Break Roll
E0	3291	Sd T9Gate
F0	3204	Sd Roll Mono
F#0	2459	HipHop Snap2
G0	3351	Sd HipHop2
G#0	3368	Sd HipHop Rim3
A0	2645	Bd T9-2
A#0	3324	Sd Hip Rim3
B0	2644	Bd T9-1
C1	2652	Bd T8-2
C#1	3368	Sd HipHop Rim3
D1	3315	Sd R&B1
D#1	2447	HipHop Clap6
E1	3321	Sd Hip Gate
F1	3855	Tom T9 Lo
F#1	3610	HH Closed T9
G1	3855	Tom T9 Lo
G#1	3611	HH Open T9
A1	3855	Tom T9 Lo
A#1	3611	HH Open T9
B1	3855	Tom T9 Lo
C2	3854	Tom T9 Hi
C#2	3866	Crash1 RL
D2	2653	Bd T8-3
D#2	3911	Ride2 St
E2	3958	China2
F2	3952	Ride Cup Mono
F#2	1929	Tambourine1 Hit
G2	3871	Crash3
G#2	2109	Cowbell1
A2	3863	Crash1 St
A#2	2428	Cowbell T8
B2	3907	Ride1 St
C3	2007	Bongo1 Hi 1Fingr 1-2
C#3	2020	Bongo1 Lo 3Fingr 1-2
D3	1966	Conga1 Hi Tip
D#3	1972	Conga1 Hi Slap Open
E3	1970	Conga1 Hi Open 2
F3	1726	Hi Q1
F#3	1726	Hi Q1
G3	2081	Agogo Lo
G#3	2081	Agogo Lo
A3	2432	Analog Shaker
A#3	2057	Maracas Slur
B3	1606	Vox Drum
C4	1606	Vox Drum
C#4	1726	Hi Q1
D4	1727	Hi Q2
D#4	2439	Claves T8
E4	1726	Hi Q1
F4	1762	Scratch Spin
F#4	1752	Scratch Hi R
G4	1751	Scratch Hi F
G#4	1944	Triangle Mute
A4	1943	Triangle Open
A#4	1918	ShakerA 2
B4	1929	Tambourine1 Hit
C5	1957	Wind Chime
C#5	3331	Sd Break Roll
D5	1708	Noise Burst
D#5	1539	Vox Bell
E5	3315	Sd R&B1
F5	1545	VoxAlk
F#5	2220	Udu High
G5	1543	Trance Choir
G#5	1734	Swarm
A5	2528	Bd Pop
A#5	3316	Sd R&B1 Rim
B5	2667	Bd R&B2
C6	3871	Crash3

PDR 19 Trance Kit

Note	Wave Number	Wave Name
C0	2645	Bd T9-2
C#0	3302	Sd AnSm Rim
D0	3282	Sd Elec9
D#0	2424	Clap AnSm
E0	3280	Sd Elec7
F0	3284	Sd Elec11
F#0	3280	Sd Elec7
G0	3293	Sd T8-1
G#0	3290	Sd T9-5
A0	2649	Bd T9 Hd2
A#0	3285	Sd Elec12
B0	2650	Bd T9 Hd3
C1	2686	Bd Hard Long
C#1	3292	Sd T9Rim
D1	3278	Sd Elec5
D#1	2423	Clap T9
E1	3287	Sd T9-2
F1	3343	Sd Syn
F#1	3610	HH Closed T9
G1	3343	Sd Syn
G#1	3611	HH Open T9
A1	3343	Sd Syn
A#1	3611	HH Open T9
B1	3343	Sd Syn
C2	3343	Sd Syn
C#2	3971	Crash T9
D2	3343	Sd Syn
D#2	3975	Ride T9
E2	3973	Crash Syn
F2	3952	Ride Cup Mono
F#2	1929	Tambourine1 Hit
G2	3972	Crash T8
G#2	2428	Cowbell T8
A2	3954	China1 St
A#2	2428	Cowbell T8
B2	3907	Ride1 St
C3	2007	Bongo1 Hi 1Fingr 1-2
C#3	2020	Bongo1 Lo 3Fingr 1-2
D3	1973	Conga1 Hi Slap
D#3	1972	Conga1 Hi Slap Open
E3	1970	Conga1 Hi Open 2
F3	3857	Tom Syn1
F#3	3857	Tom Syn1
G3	2441	Analog Click
G#3	1708	Noise Burst
A3	2061	CabasaA 2
A#3	2057	Maracas Slur
B3	1619	Neo Seq Em-3
C4	1635	Neo Seq2 Em-5
C#4	1711	Electric Perc1
D4	1923	Shaker Hip1
D#4	2439	Claves T8
E4	2433	Tambourine RX5
F4	2429	Cowbell RX11
F#4	1924	Shaker Hip2
G4	1720	Electric Perc10
G#4	1944	Triangle Mute
A4	1943	Triangle Open
A#4	1926	Shaker Hip4
B4	1710	Zap2
C5	2712	Bd HipHop8
C#5	2648	Bd T9 Hd1
D5	2698	Bd ElecComp3
D#5	2644	Bd T9-1
E5	2650	Bd T9 Hd3
F5	2686	Bd Hard Long
F#5	3612	HH Closed T8-1
G5	2697	Bd ElecComp2
G#5	3615	HH Open T8-2
A5	2648	Bd T9 Hd1
A#5	3613	HH Open T8-1
B5	2649	Bd T9 Hd2
C6	2698	Bd ElecComp3

PDR 20 Psychedelic Kit

Note	Wave Number	Wave Name
C0	1660	LFO Seq
C#0	1543	Trance Choir
D0	2150	Tibetan Bowl
D#0	1761	Scratch Stop
E0	1679	Fx Female Voice St
F0	1602	Stab Organ2
F#0	1737	Door Squeak
G0	1659	Radio Noise
G#0	1737	Door Squeak
A0	1889	Acoustic Bass FX06
A#0	1894	Electric Bass FX 02
B0	1889	Acoustic Bass FX06
C1	2660	Bd BlpHd
C#1	2659	Bd Blip
D1	3321	Sd Hip Gate
D#1	2851	Sd SonA St1-4
E1	1708	Noise Burst
F1	3861	Tom Dist Lo
F#1	3610	HH Closed T9
G1	3860	Tom Dist Hi
G#1	3374	HH Closed 2St
A1	3854	Tom T9 Hi
A#1	3611	HH Open T9
B1	3854	Tom T9 Hi
C2	3854	Tom T9 Hi
C#2	3954	China1 St
D2	3854	Tom T9 Hi
D#2	3963	Splash1 St
E2	3971	Crash T9
F2	3975	Ride T9
F#2	2075	Pandeiro Tip
G2	2435	Electric Tambourine1
G#2	1727	Hi Q2
A2	2642	Bd Gate
A#2	1727	Hi Q2
B2	1886	Acoustic Bass FX03
C3	1884	Acoustic Bass FX01
C#3	1523	Mini Blip6
D3	1518	Mini Blip1
D#3	1519	Mini Blip2
E3	1998	Quinto1 Slap
F3	2141	Tabla Bya
F#3	2131	Djembe1 Edge
G3	2142	Tabla Nah
G#3	2225	Barasim Tak
A3	1718	Electric Perc8
A#3	1723	Electric Perc13
B3	1614	Hop FX1
C4	1563	Motion Beam
C#4	1710	Zap2
D4	1694	Digi Voice Mod
D#4	1281	Human Whistle
E4	1693	Digital Wind
F4	2441	Analog Click
F#4	3612	HH Closed T8-1
G4	3341	Sd FM
G#4	3427	HH Half Open2 RL
A4	2439	Claves T8
A#4	3613	HH Open T8-1
B4	3977	Reverse Cymbal
C5	2687	Bd Analog Tight
C#5	2698	Bd ElecComp3
D5	2650	Bd T9 Hd3
D#5	2682	Bd ZapHard
E5	2691	Bd Slimy
F5	2673	Bd Break Hard
F#5	3170	Sd BreakRim
G5	2739	Sd Soul St1-3
G#5	2956	Sd Ambience
A5	2935	Sd Rock Mute1 R
A#5	3338	Sd Cut
B5	3313	Sd D&B3
C6	3332	Sd FX1

PDR 21 Chill Out Kit

Note	Wave Number	Wave Name
C0	2651	Bd T8-1
C#0	3298	Sd T8 Rim
D0	3294	Sd T8-2
D#0	2425	Electric Clap1
E0	3284	Sd Elec11
F0	3280	Sd Elec7
F#0	3296	Sd T8-4
G0	2693	Bd Elec2
G#0	3293	Sd T8-1
A0	2712	Bd HipHop8
A#0	3295	Sd T8-3
B0	2713	Bd HipHop9
C1	2712	Bd HipHop8
C#1	3302	Sd AnSm Rim
D1	3353	Sd HipHop5
D#1	2424	Clap AnSm
E1	3354	Sd HipHop6
F1	3856	Tom T8
F#1	3612	HH Closed T8-1
G1	3856	Tom T8
G#1	3613	HH Open T8-1
A1	3856	Tom T8
A#1	3613	HH Open T8-1
B1	3856	Tom T8
C2	3856	Tom T8
C#2	3871	Crash3
D2	3856	Tom T8
D#2	3975	Ride T9
E2	3963	Splash1 St
F2	3952	Ride Cup Mono
F#2	1929	Tambourine1 Hit
G2	3972	Crash T8
G#2	2428	Cowbell T8
A2	3954	China1 St
A#2	2428	Cowbell T8
B2	3907	Ride1 St
C3	2427	Conga T8
C#3	2427	Conga T8
D3	2427	Conga T8
D#3	2427	Conga T8
E3	2427	Conga T8
F3	1973	Conga1 Hi Slap
F#3	1972	Conga1 Hi Slap Open
G3	1970	Conga1 Hi Open 2
G#3	2034	Timbale1 Hi 1
A3	2061	CabasaA 2
A#3	2057	Maracas Slur
B3	1679	Fx Female Voice St
C4	1639	Portamento Lead Seq
C#4	1719	Electric Perc9
D4	1923	Shaker Hip1
D#4	2439	Claves T8
E4	1726	Hi Q1
F4	1727	Hi Q2
F#4	1924	Shaker Hip2
G4	1725	Electric Perc15
G#4	1944	Triangle Mute
A4	1943	Triangle Open
A#4	1926	Shaker Hip4
B4	1703	Ripper
C5	2695	Bd Elec4
C#5	3318	Sd Hip1
D5	3282	Sd Elec9
D#5	3279	Sd Elec6
E5	3351	Sd HipHop2
F5	2701	Bd ElecGate
F#5	3614	HH Closed T8-2
G5	2690	Bd ThickSkin
G#5	3615	HH Open T8-2
A5	2672	Bd Break Heavy
A#5	3615	HH Open T8-2
B5	2669	Bd Break Deep
C6	2667	Bd R&B2

PDR 22 Brush Kit

Note	Wave Number	Wave Name
C0	2106	Claves1
C#0	3205	Sd Brush Soft St
D0	3217	Sd Brush Swir St
D#0	3208	Sd Brush Med St
E0	3220	Sd Brush SwirAtt St
F0	3201	Sd LiveRoll St
F#0	1935	Castanet1
G0	3205	Sd Brush Soft St
G#0	1933	Stick1
A0	2496	Bd Funk St1-2
A#0	2842	Sd Basic 3St
B0	2534	Bd Jazz1-2St
C1	2543	Bd FK Jazz St
C#1	3214	Sd Closed Rim4 St
D1	3208	Sd Brush Med St
D#1	1945	Hand Clap1 St
E1	3211	Sd Brush var1 St
F1	3835	Tom Brush Floor St
F#1	3471	HH Power CTip 1-4St
G1	3831	Tom Brush Low St
G#1	3511	HH Power CIPedal St
A1	3831	Tom Brush Low St
A#1	3515	HH Power Open EdgeSt
B1	3827	Tom Brush Mid St
C2	3827	Tom Brush Mid St
C#2	3889	Crash Brush1 St
D2	3823	Tom Brush Hi St
D#2	3939	Ride Brush1 St
E2	3954	China1 St
F2	3893	Crash Brush Cup St
F#2	1927	Tambourine1 Sw
G2	3963	Splash1 St
G#2	2110	Cowbell2
A2	3897	Crash Brush2 St
A#2	1940	Vibraslap1
B2	3943	Ride Brush2 St
C3	2007	Bongo1 Hi 1Fingr 1-2
C#3	2017	Bongo1 Lo 1Fingr 1-2
D3	1974	Conga1 Hi SlpMute1-2
D#3	1968	Conga1 Hi Open 1-2
E3	1979	Conga1 Lo Open 1-2
F3	2033	Timbale1 Hi 1-3
F#3	2037	Timbale1 Lo 1-2
G3	2080	Agogo Hi
G#3	2081	Agogo Lo
A3	2059	CabasaA 1-2
A#3	2057	Maracas Slur
B3	2108	Whistle
C4	2108	Whistle
C#4	2084	Guiro Short
D4	2083	Guiro Long
D#4	2106	Claves1
E4	1939	Wood Block
F4	1939	Wood Block
F#4	2006	Cuica Hi
G4	2005	Cuica Lo
G#4	1944	Triangle Mute
A4	1943	Triangle Open
A#4	1916	ShakerA 1/3
B4	1954	Sleigh Bell1
C5	1957	Wind Chime
C#5	2718	Sd Bld St1-4
D5	2877	Sd Blues 3St
D#5	2921	Sd Hip St1-2
E5	2818	Sd Funk St1-3
F5	2738	Sd Soul St1-4
F#5	3169	Sd LdwHMMono
G5	3172	Sd Heavy
G#5	2901	Sd Tight St1-4
A5	2886	Sd BluesHeart St1-3
A#5	2460	Bd Snap 1-2
B5	2469	Bd Tight 1-2
C6	2496	Bd Funk St1-2

PDR 23 Jazz Kit

Note	Wave Number	Wave Name
C0	2534	Bd Jazz1-2St
C#0	3207	Sd Brush Soft R
D0	3220	Sd Brush SwirAtt St
D#0	3208	Sd Brush Med St
E0	3220	Sd Brush SwirAtt St
F0	3201	Sd LiveRoll St
F#0	1935	Castanet1
G0	2922	Sd Hip 1St
G#0	1933	Stick1
A0	2501	Bd Funk 1 L
A#0	2909	Sd Tight 3St
B0	2543	Bd FK Jazz St
C1	2496	Bd Funk St1-2
C#1	3190	Sd Closed Rim St
D1	2907	Sd Tight 1St
D#1	3195	Sd RockRoll St
E1	2886	Sd BluesHeart St1-3
F1	3651	Tom Floor St
F#1	3471	HH Power CTip 1-4St
G1	3651	Tom Floor St
G#1	3511	HH Power CIPedal St
A1	3647	Tom Low St
A#1	3515	HH Power Open EdgeSt
B1	3643	Tom Mid St
C2	3643	Tom Mid St
C#2	3867	Crash2 St
D2	3639	Tom Hi St
D#2	3911	Ride2 St
E2	3954	China1 St
F2	3953	Ride Cup Mono2
F#2	1929	Tambourine1 Hit
G2	3963	Splash1 St
G#2	2109	Cowbell1
A2	3867	Crash2 St
A#2	1940	Vibraslap1
B2	3907	Ride1 St
C3	2007	Bongo1 Hi 1Fingr 1-2
C#3	2020	Bongo1 Lo 3Fingr 1-2
D3	1966	Conga1 Hi Tip
D#3	1972	Conga1 Hi Slap Open
E3	1970	Conga1 Hi Open 2
F3	2034	Timbale1 Hi 1
F#3	2034	Timbale1 Hi 1
G3	2081	Agogo Lo
G#3	2081	Agogo Lo
A3	2060	CabasaA 1
A#3	2057	Maracas Slur
B3	3207	Sd Brush Soft R
C4	3217	Sd Brush Swir St
C#4	2084	Guiro Short
D4	2083	Guiro Long
D#4	2106	Claves1
E4	1939	Wood Block
F4	1939	Wood Block
F#4	2041	Timbale1 Paila H
G4	2042	Timbale1 Paila L
G#4	1944	Triangle Mute
A4	1943	Triangle Open
A#4	1918	ShakerA 2
B4	1954	Sleigh Bell1
C5	1957	Wind Chime
C#5	2878	Sd Blues L1-3
D5	2833	Sd Funk Ay St
D#5	2894	Sd BluesHeart R1-3
E5	2872	Sd Blues St1-2
F5	2509	Bd Low L
F#5	3169	Sd LdwHMMono
G5	2527	Bd Dry2
G#5	3220	Sd Brush SwirAtt St
A5	2668	Bd Hip Deep
A#5	3204	Sd Roll Mono
B5	2495	Bd Normal 2R
C6	3897	Crash Brush2 St

PDR 24 Pop Latin Kit

Note	Wave Number	Wave Name
C0	2106	Claves1
C#0	2094	Cajon1 Kick
D0	2095	Cajon1 Slap
D#0	2096	Cajon1 Tip 1-2
E0	2106	Claves1
F0	1939	Wood Block
F#0	1945	Hand Clap1 St
G0	3912	Ride2 L
G#0	2459	HipHop Snap2
A0	1935	Castanet1
A#0	1966	Conga1 Hi Tip
B0	1967	Conga1 Hi Heel
C1	1968	Conga1 Hi Open 1-2
C#1	1971	Conga1 Hi Mute
D1	1972	Conga1 Hi Slap Open
D#1	1973	Conga1 Hi Slap
E1	1974	Conga1 Hi SlpMute1-2
F1	1977	Conga1 Lo Tip
F#1	1978	Conga1 Lo Heel
G1	1979	Conga1 Lo Open 1-2
G#1	1982	Conga1 Lo Mute
A1	1983	Conga1 Lo Slap Open
A#1	1983	Conga1 Lo Slap Open
B1	1980	Conga1 Lo Open 1
C2	2007	Bongo1 Hi 1Fingr 1-2
C#2	2010	Bongo1 Hi 3Fingr 1-2
D2	2013	Bongo1 Hi Rim
D#2	2014	Bongo1 Hi Tip
E2	2015	Bongo1 Hi Heel
F2	2016	Bongo1 Hi Slap
F#2	2017	Bongo1 Lo 1Fingr 1-2
G2	2020	Bongo1 Lo 3Fingr 1-2
G#2	2023	Bongo1 Lo Rim
A2	2024	Bongo1 Lo Tip
A#2	2020	Bongo1 Lo 3Fingr 1-2
B2	2016	Bongo1 Hi Slap
C3	2037	Timbale1 Lo 1-2
C#3	1998	Quinto1 Slap
D3	1997	Quinto1 Open
D#3	1966	Conga1 Hi Tip
E3	2001	Tumba Open
F3	2051	Paila L
F#3	2033	Timbale1 Hi 1-3
G3	2073	Pandeiro Open
G#3	2074	Pandeiro Thump
A3	2075	Pandeiro Tip
A#3	2076	Pandeiro Heel
B3	2052	Paila H
C4	2110	Cowbell2
C#4	2110	Cowbell2
D4	2080	Agogo Hi
D#4	2080	Agogo Hi
E4	2084	Guiro Short
F4	2083	Guiro Long
F#4	2086	MetalGuiro Short 1-2
G4	2089	MetalGuiro Long
G#4	1927	Tambourine1 Sw
A4	2077	Tmbourim Open
A#4	2079	Tmbourim Mute
B4	2078	Tmbourim Finger
C5	2056	Maracas Sw
C#5	1916	ShakerA 1/3
D5	2059	CabasaA 1-2
D#5	2005	Cuica Lo
E5	2006	Cuica Hi
F5	2109	Cowbell1
F#5	2117	Mambo Bell Body
G5	2152	Shekere Down
G#5	2154	Shekere Slap
A5	1944	Triangle Mute
A#5	1943	Triangle Open
B5	2108	Whistle
C6	1957	Wind Chime

PDR 25 Analog T9 Kit

Note	Wave Number	Wave Name
C0	2645	Bd T9-2
C#0	3303	Sd AnCR
D0	3290	Sd T9-5
D#0	2424	Clap AnSm
E0	3291	Sd T9Gate
F0	3195	Sd RockRoll St
F#0	3288	Sd T9-3
G0	3289	Sd T9-4
G#0	3291	Sd T9Gate
A0	2647	Bd T9-4
A#0	3290	Sd T9-5
B0	2644	Bd T9-1
C1	2646	Bd T9-3
C#1	3292	Sd T9Rim
D1	3286	Sd T9-1
D#1	2423	Clap T9
E1	3287	Sd T9-2
F1	3855	Tom T9 Lo
F#1	3610	HH Closed T9
G1	3855	Tom T9 Lo
G#1	3611	HH Open T9
A1	3855	Tom T9 Lo
A#1	3611	HH Open T9
B1	3854	Tom T9 Hi
C2	3854	Tom T9 Hi
C#2	3971	Crash T9
D2	3854	Tom T9 Hi
D#2	3975	Ride T9
E2	3958	China2
F2	3952	Ride Cup Mono
F#2	2433	Tambourine RX5
G2	3871	Crash3
G#2	2109	Cowbell1
A2	3872	Crash4
A#2	2428	Cowbell T8
B2	3913	Ride2 R
C3	2427	Conga T8
C#3	2427	Conga T8
D3	1966	Conga1 Hi Tip
D#3	1972	Conga1 Hi Slap Open
E3	1970	Conga1 Hi Open 2
F3	2033	Timbale1 Hi 1-3
F#3	2037	Timbale1 Lo 1-2
G3	2441	Analog Click
G#3	2427	Conga T8
A3	2059	CabasaA 1-2
A#3	2057	Maracas Slur
B3	1732	FxGun2
C4	1731	FxGun1
C#4	1748	Scratch H
D4	1750	Scratch Down
D#4	1726	Hi Q1
E4	1726	Hi Q1
F4	1727	Hi Q2
F#4	1749	Scratch L
G4	1749	Scratch L
G#4	1944	Triangle Mute
A4	1943	Triangle Open
A#4	2432	Analog Shaker
B4	1954	Sleigh Bell1
C5	1957	Wind Chime
C#5	2951	Sd Piccolo
D5	3297	Sd T8-5
D#5	3198	Sd RockRollD St
E5	3208	Sd Brush Med St
F5	2660	Bd BlpHd
F#5	3307	Sd Jungle1
G5	2684	Bd Sustain
G#5	3311	Sd D&B1
A5	2671	Bd Break2
A#5	3337	Sd Dist
B5	2685	Bd TekPower
C6	2679	Bd Distortion RM

PDR 26 Analog T8 Kit

Note	Wave Number	Wave Name
C0	2651	Bd T8-1
C#0	3303	Sd AnCR
D0	3296	Sd T8-4
D#0	3336	Sd ClapAna
E0	3295	Sd T8-3
F0	3856	Tom T8
F#0	3297	Sd T8-5
G0	2653	Bd T8-3
G#0	3296	Sd T8-4
A0	2652	Bd T8-2
A#0	3295	Sd T8-3
B0	1498	T8 Kick Bass
C1	2652	Bd T8-2
C#1	3298	Sd T8 Rim
D1	3294	Sd T8-2
D#1	2423	Clap T9
E1	3293	Sd T8-1
F1	3856	Tom T8
F#1	3614	HH Closed T8-2
G1	3856	Tom T8
G#1	3613	HH Open T8-1
A1	3856	Tom T8
A#1	3613	HH Open T8-1
B1	3856	Tom T8
C2	3856	Tom T8
C#2	3972	Crash T8
D2	3856	Tom T8
D#2	3975	Ride T9
E2	3958	China2
F2	3952	Ride Cup Mono
F#2	2433	Tambourine RX5
G2	3965	Splash1 R
G#2	2428	Cowbell T8
A2	3872	Crash4
A#2	1940	Vibraslap1
B2	3913	Ride2 R
C3	2427	Conga T8
C#3	2427	Conga T8
D3	2427	Conga T8
D#3	2427	Conga T8
E3	2427	Conga T8
F3	2034	Timbale1 Hi 1
F#3	2038	Timbale1 Lo 1
G3	1704	Glass
G#3	1704	Glass
A3	2059	CabasaA 1-2
A#3	2437	MaracasT8
B3	1732	FxGun2
C4	1731	FxGun1
C#4	2432	Analog Shaker
D4	2432	Analog Shaker
D#4	2439	Claves T8
E4	1726	Hi Q1
F4	1727	Hi Q2
F#4	1749	Scratch L
G4	1749	Scratch L
G#4	1944	Triangle Mute
A4	1943	Triangle Open
A#4	2432	Analog Shaker
B4	1954	Sleigh Bell1
C5	1957	Wind Chime
C#5	3318	Sd Hip1
D5	3319	Sd Hip2
D#5	3321	Sd Hip Gate
E5	3327	Sd Break1
F5	2659	Bd Blip
F#5	3332	Sd FX1
G5	2681	Bd FxHammer
G#5	3347	Sd Hammer
A5	2682	Bd ZapHard
A#5	3340	Sd Garg L
B5	2685	Bd TekPower
C6	2691	Bd Slimy

PDR 27 Tekno Kit

Note	Wave Number	Wave Name
C0	2691	Bd Slimy
C#0	3292	Sd T9Rim
D0	3297	Sd T8-5
D#0	2423	Clap T9
E0	3288	Sd T9-3
F0	3305	Sd Human1
F#0	3320	Sd Hip3
G0	3289	Sd T9-4
G#0	3319	Sd Hip2
A0	2690	Bd ThickSkin
A#0	3287	Sd T9-2
B0	2677	Bd Distortion4
C1	2683	Bd ZapMid
C#1	3298	Sd T8 Rim
D1	3297	Sd T8-5
D#1	2423	Clap T9
E1	3343	Sd Syn
F1	3856	Tom T8
F#1	3632	HH Closed Lo-Fi
G1	3856	Tom T8
G#1	3633	HH Open Lo-Fi
A1	3856	Tom T8
A#1	3633	HH Open Lo-Fi
B1	3856	Tom T8
C2	3856	Tom T8
C#2	3972	Crash T8
D2	3856	Tom T8
D#2	3975	Ride T9
E2	3871	Crash3
F2	3952	Ride Cup Mono
F#2	2434	Tambourine AnCR
G2	3868	Crash2 L
G#2	2428	Cowbell T8
A2	3971	Crash T9
A#2	2428	Cowbell T8
B2	3973	Crash Syn
C3	2427	Conga T8
C#3	2427	Conga T8
D3	2427	Conga T8
D#3	2427	Conga T8
E3	2427	Conga T8
F3	2033	Timbale1 Hi 1-3
F#3	2037	Timbale1 Lo 1-2
G3	1704	Glass
G#3	1704	Glass
A3	2060	CabasaA 1
A#3	2437	MaracasT8
B3	1732	FxGun2
C4	1731	FxGun1
C#4	1748	Scratch H
D4	1750	Scratch Down
D#4	1726	Hi Q1
E4	1726	Hi Q1
F4	1727	Hi Q2
F#4	1749	Scratch L
G4	1749	Scratch L
G#4	1944	Triangle Mute
A4	1943	Triangle Open
A#4	2432	Analog Shaker
B4	1954	Sleigh Bell1
C5	2695	Bd Elec4
C#5	2698	Bd ElecComp3
D5	2700	Bd ElecFX2
D#5	2702	Bd ElecClick
E5	2703	Bd ElecPower1
F5	2704	Bd ElecPower2
F#5	2694	Bd Elec3
G5	2692	Bd Elec1
G#5	3279	Sd Elec6
A5	3280	Sd Elec7
A#5	3281	Sd Elec8
B5	3282	Sd Elec9
C6	3285	Sd Elec12

PDR 28 House Kit 1

Note	Wave Number	Wave Name
C0	2647	Bd T9-4
C#0	3298	Sd T8 Rim
D0	3297	Sd T8-5
D#0	1945	Hand Clap1 St
E0	3340	Sd Garg L
F0	3201	Sd LiveRoll St
F#0	3288	Sd T9-3
G0	3293	Sd T8-1
G#0	3290	Sd T9-5
A0	2644	Bd T9-1
A#0	3291	Sd T9Gate
B0	2645	Bd T9-2
C1	2645	Bd T9-2
C#1	3292	Sd T9Rim
D1	3286	Sd T9-1
D#1	2423	Clap T9
E1	3287	Sd T9-2
F1	3855	Tom T9 Lo
F#1	3612	HH Closed T8-1
G1	3855	Tom T9 Lo
G#1	3611	HH Open T9
A1	3855	Tom T9 Lo
A#1	3611	HH Open T9
B1	3854	Tom T9 Hi
C2	3854	Tom T9 Hi
C#2	3971	Crash T9
D2	3854	Tom T9 Hi
D#2	3975	Ride T9
E2	3871	Crash3
F2	3952	Ride Cup Mono
F#2	1929	Tambourine 1 Hit
G2	3871	Crash3
G#2	2109	Cowbell1
A2	3867	Crash2 St
A#2	2428	Cowbell T8
B2	3907	Ride1 St
C3	2007	Bongo1 Hi 1Fingr 1-2
C#3	2020	Bongo1 Lo 3Fingr 1-2
D3	1966	Conga1 Hi Tip
D#3	1972	Conga1 Hi Slap Open
E3	1970	Conga1 Hi Open 2
F3	2034	Timbale1 Hi 1
F#3	2034	Timbale1 Hi 1
G3	2081	Agogo Lo
G#3	2081	Agogo Lo
A3	2060	CabasaA 1
A#3	2057	Maracas Slur
B3	1606	Vox Drum
C4	1606	Vox Drum
C#4	2084	Guiro Short
D4	2083	Guiro Long
D#4	2106	Claves1
E4	1939	Wood Block
F4	1939	Wood Block
F#4	2006	Cuica Hi
G4	2005	Cuica Lo
G#4	1944	Triangle Mute
A4	1943	Triangle Open
A#4	2432	Analog Shaker
B4	1954	Sleigh Bell1
C5	1957	Wind Chime
C#5	3331	Sd Break Roll
D5	1708	Noise Burst
D#5	1539	Vox Bell
E5	3315	Sd R&B1
F5	1545	VoxAlk
F#5	2220	Udu High
G5	1543	Trance Choir
G#5	1734	Swarm
A5	2528	Bd Pop
A#5	3316	Sd R&B1 Rim
B5	2667	Bd R&B2
C6	3871	Crash3

PDR 29 House Kit 2

Note	Wave Number	Wave Name
C0	2645	Bd T9-2
C#0	3298	Sd T8 Rim
D0	2146	Dohol High
D#0	2423	Clap T9
E0	3287	Sd T9-2
F0	3291	Sd T9Gate
F#0	3306	Sd Human2
G0	3332	Sd FX1
G#0	3348	Sd Lo-Fi
A0	2649	Bd T9 Hd2
A#0	3292	Sd T9Rim
B0	2646	Bd T9-3
C1	2648	Bd T9 Hd1
C#1	3292	Sd T9Rim
D1	3287	Sd T9-2
D#1	1708	Noise Burst
E1	2768	Sd Strong L1-4
F1	3343	Sd Syn
F#1	3610	HH Closed T9
G1	3343	Sd Syn
G#1	3611	HH Open T9
A1	3343	Sd Syn
A#1	3611	HH Open T9
B1	3343	Sd Syn
C2	3343	Sd Syn
C#2	3971	Crash T9
D2	3343	Sd Syn
D#2	3975	Ride T9
E2	3973	Crash Syn
F2	3952	Ride Cup Mono
F#2	1929	Tambourine1 Hit
G2	3972	Crash T8
G#2	2109	Cowbell1
A2	3871	Crash3
A#2	2428	Cowbell T8
B2	3907	Ride1 St
C3	2007	Bongo1 Hi 1Fingr 1-2
C#3	2020	Bongo1 Lo 3Fingr 1-2
D3	1967	Conga1 Hi Heel
D#3	1972	Conga1 Hi Slap Open
E3	1970	Conga1 Hi Open 2
F3	3857	Tom Syn1
F#3	3857	Tom Syn1
G3	2441	Analog Click
G#3	3349	Sd Rim SE
A3	2060	CabasaA 1
A#3	2057	Maracas Slur
B3	1606	Vox Drum
C4	1606	Vox Drum
C#4	2434	Tambourine AnCR
D4	2432	Analog Shaker
D#4	2439	Claves T8
E4	2433	Tambourine RX5
F4	2429	Cowbell RX11
F#4	2432	Analog Shaker
G4	1751	Scratch Hi F
G#4	1944	Triangle Mute
A4	1943	Triangle Open
A#4	2432	Analog Shaker
B4	1954	Sleigh Bell1
C5	1957	Wind Chime
C#5	2141	Tabla Bya
D5	2142	Tabla Nah
D#5	2143	Tabla Mute
E5	1539	Vox Bell
F5	2528	Bd Pop
F#5	2220	Udu High
G5	2643	Bd FX Gate
G#5	1708	Noise Burst
A5	2644	Bd T9-1
A#5	3331	Sd Break Roll
B5	3871	Crash3
C6	1735	TurnTable

PDR 30 House Compressed Kit

Note	Wave Number	Wave Name
C0	2647	Bd T9-4
C#0	3298	Sd T8 Rim
D0	3297	Sd T8-5
D#0	1945	Hand Clap1 St
E0	3340	Sd Garg L
F0	3201	Sd LiveRoll St
F#0	3288	Sd T9-3
G0	3293	Sd T8-1
G#0	3290	Sd T9-5
A0	2644	Bd T9-1
A#0	3291	Sd T9Gate
B0	2645	Bd T9-2
C1	2646	Bd T9-3
C#1	3292	Sd T9Rim
D1	3286	Sd T9-1
D#1	2423	Clap T9
E1	3287	Sd T9-2
F1	3855	Tom T9 Lo
F#1	3612	HH Closed T8-1
G1	3855	Tom T9 Lo
G#1	3611	HH Open T9
A1	3855	Tom T9 Lo
A#1	3611	HH Open T9
B1	3854	Tom T9 Hi
C2	3854	Tom T9 Hi
C#2	3971	Crash T9
D2	3854	Tom T9 Hi
D#2	3975	Ride T9
E2	3871	Crash3
F2	3952	Ride Cup Mono
F#2	1929	Tambourine1 Hit
G2	3871	Crash3
G#2	2109	Cowbell1
A2	3867	Crash2 St
A#2	2428	Cowbell T8
B2	3907	Ride1 St
C3	2007	Bongo1 Hi 1Fingr 1-2
C#3	2020	Bongo1 Lo 3Fingr 1-2
D3	1966	Conga1 Hi Tip
D#3	1972	Conga1 Hi Slap Open
E3	1970	Conga1 Hi Open 2
F3	2034	Timbale1 Hi 1
F#3	2034	Timbale1 Hi 1
G3	2081	Agogo Lo
G#3	2081	Agogo Lo
A3	2060	CabasaA 1
A#3	2057	Maracas Slur
B3	1606	Vox Drum
C4	1606	Vox Drum
C#4	2084	Guiro Short
D4	2083	Guiro Long
D#4	2106	Claves1
E4	1939	Wood Block
F4	1939	Wood Block
F#4	2006	Cuica Hi
G4	2005	Cuica Lo
G#4	1944	Triangle Mute
A4	1943	Triangle Open
A#4	2432	Analog Shaker
B4	1954	Sleigh Bell1
C5	1957	Wind Chime
C#5	3331	Sd Break Roll
D5	1708	Noise Burst
D#5	1539	Vox Bell
E5	3315	Sd R&B1
F5	1545	VoxAlk
F#5	2220	Udu High
G5	1543	Trance Choir
G#5	1734	Swarm
A5	2528	Bd Pop
A#5	3316	Sd R&B1 Rim
B5	2667	Bd R&B2
C6	3871	Crash3

PDR 31 Big Kit

Note	Wave Number	Wave Name
C0	2643	Bd FX Gate
C#0	2020	Bongo1 Lo 3Fingr 1-2
D0	3173	Sd GM
D#0	1945	Hand Clap1 St
E0	3168	Sd Gate2
F0	3195	Sd RockRoll St
F#0	2936	Sd Rock Rim1 St
G0	2951	Sd Piccolo
G#0	2948	Sd Rock Flam St
A0	2532	Bd Room2
A#0	3174	Sd Rock Stick1 St
B0	2533	Bd Room3
C1	2642	Bd Gate
C#1	2955	Sd Mid Rim
D1	3167	Sd Gate1
D#1	2424	Clap AnSm
E1	2956	Sd Ambience
F1	3853	Tom Ambience Lo
F#1	3623	HH Closed D&B
G1	3853	Tom Ambience Lo
G#1	3624	HH Pedal D&B
A1	3853	Tom Ambience Lo
A#1	3625	HH Open D&B
B1	3852	Tom Ambience Hi
C2	3852	Tom Ambience Hi
C#2	3870	Crash2 RL
D2	3852	Tom Ambience Hi
D#2	3907	Ride1 St
E2	3954	China1 St
F2	3952	Ride Cup Mono
F#2	1929	Tambourine1 Hit
G2	3871	Crash3
G#2	2109	Cowbell1
A2	3867	Crash2 St
A#2	1940	Vibraslap1
B2	3910	Ride1 RL
C3	2007	Bongo1 Hi 1Fingr 1-2
C#3	2020	Bongo1 Lo 3Fingr 1-2
D3	1966	Conga1 Hi Tip
D#3	1972	Conga1 Hi Slap Open
E3	1970	Conga1 Hi Open 2
F3	2680	Bd +HH
F#3	2680	Bd +HH
G3	2081	Agogo Lo
G#3	2081	Agogo Lo
A3	2060	CabasaA 1
A#3	2057	Maracas Slur
B3	1732	FxGun2
C4	1731	FxGun1
C#4	1748	Scratch H
D4	1750	Scratch Down
D#4	2106	Claves1
E4	1939	Wood Block
F4	1939	Wood Block
F#4	1749	Scratch L
G4	1749	Scratch L
G#4	1944	Triangle Mute
A4	1943	Triangle Open
A#4	1918	Shaker A 2
B4	1954	Sleigh Bell1
C5	1957	Wind Chime
C#5	3337	Sd Dist
D5	3341	Sd FM
D#5	3342	Sd FM Rim
E5	3344	Sd Clappy
F5	2533	Bd Room3
F#5	3345	Sd Timbr
G5	2520	Bd Rock1 St
G#5	3349	Sd Rim SE
A5	2523	Bd Rock2 St
A#5	3331	Sd Break Roll
B5	2664	Bd D&B1
C6	2532	Bd Room2

PDR 32 Break Kit

Note	Wave Number	Wave Name
C0	2669	Bd Break Deep
C#0	2922	Sd Hip 1St
D0	3348	Sd Lo-Fi
D#0	3344	Sd Clappy
E0	3169	Sd LdwHMono
F0	3198	Sd RockRollID St
F#0	3167	Sd Gate1
G0	2954	Sd Mid
G#0	3170	Sd BreakRim
A0	2672	Bd Break Heavy
A#0	3325	Sd Hip Rim4
B0	2671	Bd Break2
C1	2670	Bd Break1
C#1	3322	Sd Hip Rim1
D1	3329	Sd Break3
D#1	3327	Sd Break1
E1	3328	Sd Break2
F1	3647	Tom Low St
F#1	3441	HH Closed Rock S R
G1	3647	Tom Low St
G#1	3454	HH Pedal Rock R
A1	3647	Tom Low St
A#1	3466	HH Half Open Rock R
B1	3639	Tom Hi St
C2	3639	Tom Hi St
C#2	3868	Crash2 L
D2	3639	Tom Hi St
D#2	3912	Ride2 L
E2	3955	China1 L
F2	3952	Ride Cup Mono
F#2	1929	Tambourine1 Hit
G2	3871	Crash3
G#2	2109	Cowbell1
A2	3869	Crash2 R
A#2	2429	Cowbell RX11
B2	3951	Ride Mono
C3	2007	Bongo1 Hi 1Fingr 1-2
C#3	2020	Bongo1 Lo 3Fingr 1-2
D3	1966	Conga1 Hi Tip
D#3	1972	Conga1 Hi Slap Open
E3	1970	Conga1 Hi Open 2
F3	2007	Bongo1 Hi 1Fingr 1-2
F#3	2020	Bongo1 Lo 3Fingr 1-2
G3	1970	Conga1 Hi Open 2
G#3	2081	Agogo Lo
A3	2060	CabasaA 1
A#3	2057	Maracas Slur
B3	2034	Timbale1 Hi 1
C4	2038	Timbale1 Lo 1
C#4	1748	Scratch H
D4	1750	Scratch Down
D#4	2106	Claves1
E4	1939	Wood Block
F4	1939	Wood Block
F#4	1749	Scratch L
G4	1749	Scratch L
G#4	1944	Triangle Mute
A4	1943	Triangle Open
A#4	1918	Shaker A 2
B4	1954	Sleigh Bell1
C5	1735	TurnTable
C#5	3331	Sd Break Roll
D5	1504	FM Bass5
D#5	1553	Mind Bell
E5	3332	Sd FX1
F5	2523	Bd Rock2 St
F#5	1660	LFO Seq
G5	1703	Ripper
G#5	1708	Noise Burst
A5	1736	Police
A#5	1552	Fairwave
B5	1734	Swarm
C6	1659	Radio Noise

PDR 33 Drum'n'Bass Kit

Note	Wave Number	Wave Name
C0	2668	Bd Hip Deep
C#0	2020	Bongo1 Lo 3Fingr 1-2
D0	3317	Sd R&B2
D#0	3345	Sd Timbr
E0	3313	Sd D&B3
F0	3347	Sd Hammer
F#0	1704	Glass
G0	2665	Bd D&B2
G#0	3395	HH Pedal 3 St
A0	2668	Bd Hip Deep
A#0	3428	HH Open2 St
B0	2673	Bd Break Hard
C1	2664	Bd D&B1
C#1	2955	Sd Mid Rim
D1	3311	Sd D&B1
D#1	1708	Noise Burst
E1	3312	Sd D&B2
F1	3853	Tom Ambience Lo
F#1	3623	HH Closed D&B
G1	3853	Tom Ambience Lo
G#1	3624	HH Pedal D&B
A1	3853	Tom Ambience Lo
A#1	3625	HH Open D&B
B1	3852	Tom Ambience Hi
C2	3852	Tom Ambience Hi
C#2	3868	Crash2 L
D2	3852	Tom Ambience Hi
D#2	3907	Ride1 St
E2	3958	China2
F2	3952	Ride Cup Mono
F#2	1929	Tambourine1 Hit
G2	3871	Crash3
G#2	2109	Cowbell1
A2	3867	Crash2 St
A#2	1940	Vibraslap1
B2	3907	Ride1 St
C3	2007	Bongo1 Hi 1Fingr 1-2
C#3	2020	Bongo1 Lo 3Fingr 1-2
D3	1966	Conga1 Hi Tip
D#3	1972	Conga1 Hi Slap Open
E3	1970	Conga1 Hi Open 2
F3	3314	Sd D&B4
F#3	3626	HH Reverse D&B
G3	2081	Agogo Lo
G#3	2081	Agogo Lo
A3	2060	CabasaA 1
A#3	2057	Maracas Slur
B3	1732	FxGun2
C4	1731	FxGun1
C#4	2084	Guiro Short
D4	2083	Guiro Long
D#4	2106	Claves1
E4	1718	Electric Perc8
F4	1712	Electric Perc2
F#4	1385	P50-1
G4	1723	Electric Perc13
G#4	1735	TurnTable
A4	1943	Triangle Open
A#4	1918	ShakerA 2
B4	1954	Sleigh Bell1
C5	1957	Wind Chime
C#5	3337	Sd Dist
D5	3341	Sd FM
D#5	3342	Sd FM Rim
E5	3344	Sd Clappy
F5	2664	Bd D&B1
F#5	3345	Sd Timbr
G5	2678	Bd Distortion5
G#5	3349	Sd Rim SE
A5	2677	Bd Distortion4
A#5	3320	Sd Hip3
B5	2691	Bd Slimy
C6	2680	Bd +HH

PDR 34 Acid Kit

Note	Wave Number	Wave Name
C0	2687	Bd Analog Tight
C#0	3298	Sd T8 Rim
D0	3309	Sd Jungle3
D#0	1945	Hand Clap1 St
E0	3293	Sd T8-1
F0	3857	Tom Syn1
F#0	2893	Sd BluesHeart L1-3
G0	2900	Sd BluesHeart 3R
G#0	2852	Sd SonA St1-3
A0	2496	Bd Funk St1-2
A#0	2836	Sd Basic St1-3
B0	2659	Bd Blip
C1	2647	Bd T9-4
C#1	3292	Sd T9Rim
D1	3341	Sd FM
D#1	2423	Clap T9
E1	3303	Sd AnCR
F1	3855	Tom T9 Lo
F#1	3627	HH Closed Tek
G1	3855	Tom T9 Lo
G#1	3627	HH Closed Tek
A1	3855	Tom T9 Lo
A#1	3628	HH Open Tek
B1	3854	Tom T9 Hi
C2	3854	Tom T9 Hi
C#2	3971	Crash T9
D2	3854	Tom T9 Hi
D#2	3975	Ride T9
E2	3871	Crash3
F2	3948	Ride Cup2 L
F#2	1929	Tambourine1 Hit
G2	3871	Crash3
G#2	2109	Cowbell1
A2	3966	Splash1 RL
A#2	2428	Cowbell T8
B2	3951	Ride Mono
C3	2007	Bongo1 Hi 1Fingr 1-2
C#3	2020	Bongo1 Lo 3Fingr 1-2
D3	1966	Conga1 Hi Tip
D#3	1972	Conga1 Hi Slap Open
E3	1970	Conga1 Hi Open 2
F3	2034	Timbale1 Hi 1
F#3	2034	Timbale1 Hi 1
G3	2080	Agogo Lo
G#3	2081	Agogo Lo
A3	2060	CabasaA 1
A#3	2057	Maracas Slur
B3	1732	FxGun2
C4	1731	FxGun1
C#4	1748	Scratch H
D4	1750	Scratch Down
D#4	1726	Hi Q1
E4	1726	Hi Q1
F4	1727	Hi Q2
F#4	1749	Scratch L
G4	1749	Scratch L
G#4	1944	Triangle Mute
A4	1943	Triangle Open
A#4	2432	Analog Shaker
B4	1954	Sleigh Bell1
C5	1957	Wind Chime
C#5	3290	Sd T9-5
D5	3290	Sd T9-5
D#5	3290	Sd T9-5
E5	3290	Sd T9-5
F5	2657	Bd Human1
F#5	3311	Sd D&B1
G5	1886	Acoustic Bass FX03
G#5	1428	DigiOsc4
A5	1427	DigiOsc3
A#5	3327	Sd Break1
B5	2661	Bd Jungle1
C6	2672	Bd Break Heavy

PDR 35 Jungle Kit

Note	Wave Number	Wave Name
C0	2662	Bd Jungle2
C#0	2955	Sd Mid Rim
D0	3309	Sd Jungle3
D#0	3309	Sd Jungle3
E0	2952	Sd Piccolo Rim1
F0	3204	Sd Roll Mono
F#0	3346	Sd Wood
G0	3317	Sd R&B2
G#0	3312	Sd D&B2
A0	2662	Bd Jungle2
A#0	3310	Sd JungleFX
B0	2651	Bd T8-1
C1	2661	Bd Jungle1
C#1	3325	Sd Hip Rim4
D1	3308	Sd Jungle2
D#1	3310	Sd JungleFX
E1	3309	Sd Jungle3
F1	3652	Tom Floor L
F#1	3439	HH Closed Rock Sw R
G1	3648	Tom Low L
G#1	3447	HH Pedal Rock Sw R
A1	3645	Tom Mid R
A#1	3462	HH Open Rock Sw R
B1	3645	Tom Mid R
C2	3641	Tom Hi R
C#2	3868	Crash2 L
D2	3641	Tom Hi R
D#2	3913	Ride2 R
E2	3958	China2
F2	3952	Ride Cup Mono
F#2	1929	Tambourine1 Hit
G2	3871	Crash3
G#2	2109	Cowbell1
A2	3867	Crash2 St
A#2	1940	Vibraslap1
B2	3907	Ride1 St
C3	2007	Bongo1 Hi 1Fingr 1-2
C#3	2020	Bongo1 Lo 3Fingr 1-2
D3	1966	Conga1 Hi Tip
D#3	1972	Conga1 Hi Slap Open
E3	1970	Conga1 Hi Open 2
F3	2142	Tabla Nah
F#3	2141	Tabla Bya
G3	2081	Agogo Lo
G#3	2081	Agogo Lo
A3	2060	CabasaA 1
A#3	2057	Maracas Slur
B3	2034	Timbale1 Hi 1
C4	2038	Timbale1 Lo 1
C#4	2084	Guiro Short
D4	2083	Guiro Long
D#4	2106	Claves1
E4	1939	Wood Block
F4	1939	Wood Block
F#4	2006	Cuica Hi
G4	2005	Cuica Lo
G#4	1944	Triangle Mute
A4	1943	Triangle Open
A#4	1918	ShakerA 2
B4	1954	Sleigh Bell1
C5	1957	Wind Chime
C#5	3626	HH Reverse D&B
D5	1747	RainLoop
D#5	1748	Scratch H
E5	1749	Scratch L
F5	2660	Bd BlpHd
F#5	3343	Sd Syn
G5	1707	IndusTom
G#5	2073	Pandeiro Open
A5	1703	Ripper
A#5	1742	TelRing
B5	1754	Scratch Lo R
C6	1730	Tape Rewind

PDR 36 Electric Kit

Note	Wave Number	Wave Name
C0	2655	Bd AnCR
C#0	2659	Bd Blip
D0	3297	Sd T8-5
D#0	2424	Clap AnSm
E0	3323	Sd Hip Rim2
F0	3204	Sd Roll Mono
F#0	3293	Sd T8-1
G0	3303	Sd AnCR
G#0	3294	Sd T8-2
A0	2651	Bd T8-1
A#0	3296	Sd T8-4
B0	2659	Bd Blip
C1	2652	Bd T8-2
C#1	3298	Sd T8 Rim
D1	3295	Sd T8-3
D#1	2423	Clap T9
E1	2424	Clap AnSm
F1	3858	Tom Syn2
F#1	3614	HH Closed T8-2
G1	3858	Tom Syn2
G#1	3613	HH Open T8-1
A1	3858	Tom Syn2
A#1	3615	HH Open T8-2
B1	3858	Tom Syn2
C2	3858	Tom Syn2
C#2	3971	Crash T9
D2	3858	Tom Syn2
D#2	3975	Ride T9
E2	3871	Crash3
F2	3973	Crash Syn
F#2	3972	Crash T8
G2	3871	Crash3
G#2	3349	Sd Rim SE
A2	3867	Crash2 St
A#2	2428	Cowbell T8
B2	3973	Crash Syn
C3	3856	Tom T8
C#3	3856	Tom T8
D3	3856	Tom T8
D#3	3856	Tom T8
E3	3856	Tom T8
F3	1746	Applause
F#3	1737	Door Squeak
G3	1738	Heart Beat
G#3	1729	Bomb
A3	3633	HH Open Lo-Fi
A#3	1917	ShakerA 1
B3	1710	Zap2
C4	1709	Zap1
C#4	1748	Scratch H
D4	1749	Scratch L
D#4	1726	Hi Q1
E4	1726	Hi Q1
F4	1727	Hi Q2
F#4	1749	Scratch L
G4	1605	Hit Orchestra2
G#4	3636	HH Closed FX
A4	3637	HH Open FX
A#4	2432	Analog Shaker
B4	2432	Analog Shaker
C5	1735	TurnTable
C#5	3331	Sd Break Roll
D5	1504	FM Bass5
D#5	1553	Mind Bell
E5	3328	Sd Break2
F5	2523	Bd Rock2 St
F#5	1659	Radio Noise
G5	1703	Ripper
G#5	1708	Noise Burst
A5	1762	Scratch Spin
A#5	1673	Bell Choir
B5	1546	Hi-Lo
C6	1659	Radio Noise

PDR 37 Human Kit

Note	Wave Number	Wave Name
C0	2657	Bd Human1
C#0	1759	Scratch Vo F
D0	1604	Hit Uhh
D#0	1760	Scratch Vo R
E0	3310	Sd JungleFX
F0	3195	Sd RockRoll St
F#0	3327	Sd Break1
G0	3303	Sd AnCR
G#0	3286	Sd T9-1
A0	2684	Bd Sustain
A#0	3180	Sd Hip Stick1
B0	2658	Bd Human2
C1	2658	Bd Human2
C#1	3346	Sd Wood
D1	3305	Sd Human1
D#1	3339	Sd Garg H
E1	3306	Sd Human2
F1	2657	Bd Human1
F#1	3638	HH Open Human
G1	2657	Bd Human1
G#1	3638	HH Open Human
A1	2657	Bd Human1
A#1	3638	HH Open Human
B1	2657	Bd Human1
C2	2657	Bd Human1
C#2	1708	Noise Burst
D2	2657	Bd Human1
D#2	3972	Crash T8
E2	3958	China2
F2	3952	Ride Cup Mono
F#2	1758	Scratch Sd R
G2	3963	Splash1 St
G#2	1606	Vox Drum
A2	3872	Crash4
A#2	2436	Electric Tambourine2
B2	1603	Stab Aah
C3	2007	Bongo1 Hi 1Fingr 1-2
C#3	2020	Bongo1 Lo 3Fingr 1-2
D3	1966	Conga1 Hi Tip
D#3	1972	Conga1 Hi Slap Open
E3	1970	Conga1 Hi Open 2
F3	2033	Timbale1 Hi 1-3
F#3	2037	Timbale1 Lo 1-2
G3	2081	Agogo Lo
G#3	2081	Agogo Lo
A3	2060	CabasaA 1
A#3	2057	Maracas Slur
B3	1732	FxGun2
C4	1729	Bomb
C#4	1748	Scratch H
D4	1750	Scratch Down
D#4	1753	Scratch Lo F
E4	1754	Scratch Lo R
F4	1727	Hi Q2
F#4	1749	Scratch L
G4	1749	Scratch L
G#4	1944	Triangle Mute
A4	1943	Triangle Open
A#4	1918	ShakerA 2
B4	1954	Sleigh Bell1
C5	1735	TurnTable
C#5	2938	Sd Rock Rim1 R
D5	1739	Helicopter
D#5	1601	Stab Hard
E5	3167	Sd Gate1
F5	2520	Bd Rock1 St
F#5	1750	Scratch Down
G5	2654	Bd AnSm
G#5	1554	Sonar1
A5	2178	Wa Taiko
A#5	2178	Wa Taiko
B5	1596	HH Hit
C6	1602	Stab Organ2

PDR 38 Hard Kit

Note	Wave Number	Wave Name
C0	2676	Bd Distortion3
C#0	3346	Sd Wood
D0	3167	Sd Gate1
D#0	1945	Hand Clap1 St
E0	3168	Sd Gate2
F0	3204	Sd Roll Mono
F#0	3336	Sd ClapAna
G0	3320	Sd Hip3
G#0	1703	Ripper
A0	2679	Bd Distortion RM
A#0	3298	Sd T8 Rim
B0	2675	Bd Distortion2
C1	2674	Bd Distortion1
C#1	2955	Sd Mid Rim
D1	3337	Sd Dist
D#1	1708	Noise Burst
E1	3333	Sd FX2
F1	3861	Tom Dist Lo
F#1	3610	HH Closed T9
G1	3861	Tom Dist Lo
G#1	3611	HH Open T9
A1	3861	Tom Dist Lo
A#1	3611	HH Open T9
B1	3860	Tom Dist Hi
C2	3860	Tom Dist Hi
C#2	3971	Crash T9
D2	3860	Tom Dist Hi
D#2	3975	Ride T9
E2	3958	China2
F2	3952	Ride Cup Mono
F#2	2434	Tambourine AnCR
G2	3871	Crash3
G#2	2428	Cowbell T8
A2	3867	Crash2 St
A#2	1940	Vibraslap1
B2	3907	Ride1 St
C3	3345	Sd Timbr
C#3	3345	Sd Timbr
D3	1966	Conga1 Hi Tip
D#3	1972	Conga1 Hi Slap Open
E3	1970	Conga1 Hi Open 2
F3	2680	Bd +HH
F#3	2680	Bd +HH
G3	1704	Glass
G#3	1704	Glass
A3	2060	CabasaA 1
A#3	2057	Maracas Slur
B3	1732	FxGun2
C4	1731	FxGun1
C#4	1748	Scratch H
D4	1750	Scratch Down
D#4	1726	Hi Q1
E4	1726	Hi Q1
F4	1727	Hi Q2
F#4	1749	Scratch L
G4	1749	Scratch L
G#4	1944	Triangle Mute
A4	1943	Triangle Open
A#4	2432	Analog Shaker
B4	1954	Sleigh Bell1
C5	1957	Wind Chime
C#5	3337	Sd Dist
D5	3341	Sd FM
D#5	3342	Sd FM Rim
E5	3344	Sd Clappy
F5	2681	Bd FxHammer
F#5	1707	IndusTom
G5	2664	Bd D&B1
G#5	1707	IndusTom
A5	2533	Bd Room3
A#5	1707	IndusTom
B5	2647	Bd T9-4
C6	3347	Sd Hammer

PDR 39 Distorted Kit

Note	Wave Number	Wave Name
C0	2441	Analog Click
C#0	3205	Sd Brush Soft St
D0	3217	Sd Brush Swir St
D#0	3208	Sd Brush Med St
E0	3220	Sd Brush SwirAtt St
F0	3201	Sd LiveRoll St
F#0	1935	Castanet1
G0	2804	Sd Normal 1St
G#0	1933	Stick1
A0	2525	Bd Rock2 R
A#0	2907	Sd Tight 1St
B0	2670	Bd Break1
C1	2525	Bd Rock2 R
C#1	3179	Sd Rock Stick2 R
D1	2863	Sd SonA 1L
D#1	1946	Hand Clap1 L
E1	2952	Sd Piccolo Rim1
F1	3853	Tom Ambience Lo
F#1	3450	HH Closed Rock 2R
G1	3853	Tom Ambience Lo
G#1	3454	HH Pedal Rock R
A1	3853	Tom Ambience Lo
A#1	3464	HH Open Rock R
B1	3852	Tom Ambience Hi
C2	3852	Tom Ambience Hi
C#2	3868	Crash2 L
D2	3852	Tom Ambience Hi
D#2	3913	Ride2 R
E2	3955	China1 L
F2	3949	Ride Cup2 R
F#2	1927	Tambourine1 Sw
G2	3965	Splash1 R
G#2	2116	Mambo Bell2
A2	3868	Crash2 L
A#2	1940	Vibraslap1
B2	3910	Ride1 RL
C3	2007	Bongo1 Hi 1Fingr 1-2
C#3	2020	Bongo1 Lo 3Fingr 1-2
D3	1966	Conga1 Hi Tip
D#3	1972	Conga1 Hi Slap Open
E3	1970	Conga1 Hi Open 2
F3	2033	Timbale1 Hi 1-3
F#3	2037	Timbale1 Lo 1-2
G3	2080	Agogo Hi
G#3	2081	Agogo Lo
A3	2059	CabasaA 1-2
A#3	2057	Maracas Slur
B3	2108	Whistle
C4	2108	Whistle
C#4	2084	Guiro Short
D4	2083	Guiro Long
D#4	2106	Claves1
E4	1939	Wood Block
F4	1939	Wood Block
F#4	1768	Scratch Combi2
G4	1752	Scratch Hi R
G#4	1944	Triangle Mute
A4	1943	Triangle Open
A#4	1917	ShakerA 1
B4	1954	Sleigh Bell1
C5	1957	Wind Chime
C#5	2951	Sd Piccolo
D5	3172	Sd Heavy
D#5	3336	Sd ClapAna
E5	2952	Sd Piccolo Rim1
F5	2532	Bd Room2
F#5	2954	Sd Mid
G5	2533	Bd Room3
G#5	2955	Sd Mid Rim
A5	2642	Bd Gate
A#5	3167	Sd Gate1
B5	2643	Bd FX Gate
C6	2664	Bd D&B1

PDR 40 Ambient Kit

Note	Wave Number	Wave Name
C0	2659	Bd Blip
C#0	1727	Hi Q2
D0	2953	Sd Piccolo Rim2
D#0	1726	Hi Q1
E0	3303	Sd AnCR
F0	3857	Tom Syn1
F#0	3634	HH Closed Syn
G0	3857	Tom Syn1
G#0	3636	HH Closed FX
A0	3858	Tom Syn2
A#0	3635	HH Open Syn
B0	2655	Bd AnCR
C1	2644	Bd T9-1
C#1	3182	Sd Hip Stick3
D1	3307	Sd Jungle1
D#1	2423	Clap T9
E1	3307	Sd Jungle1
F1	3856	Tom T8
F#1	3614	HH Closed T8-2
G1	3856	Tom T8
G#1	3613	HH Open T8-1
A1	3856	Tom T8
A#1	3615	HH Open T8-2
B1	3856	Tom T8
C2	3856	Tom T8
C#2	3973	Crash Syn
D2	3856	Tom T8
D#2	3975	Ride T9
E2	3871	Crash3
F2	3952	Ride Cup Mono
F#2	1929	Tambourine1 Hit
G2	3871	Crash3
G#2	2428	Cowbell T8
A2	3867	Crash2 St
A#2	1940	Vibraslap1
B2	3907	Ride1 St
C3	2007	Bongo1 Hi 1Fingr 1-2
C#3	2020	Bongo1 Lo 3Fingr 1-2
D3	1966	Conga1 Hi Tip
D#3	1972	Conga1 Hi Slap Open
E3	1970	Conga1 Hi Open 2
F3	2033	Timbale1 Hi 1-3
F#3	2037	Timbale1 Lo 1-2
G3	1704	Glass
G#3	1704	Glass
A3	2060	CabasaA 1
A#3	2437	MaracasT8
B3	1743	Bird
C4	1557	Engine Room St
C#4	1724	Electric Perc14
D4	1745	Gunshot
D#4	2439	Claves T8
E4	1939	Wood Block
F4	1939	Wood Block
F#4	2434	Tambourine AnCR
G4	2430	Cowbell AnCR
G#4	1944	Triangle Mute
A4	1943	Triangle Open
A#4	2432	Analog Shaker
B4	1954	Sleigh Bell1
C5	1957	Wind Chime
C#5	3297	Sd T8-5
D5	1554	Sonar1
D#5	3297	Sd T8-5
E5	1554	Sonar1
F5	1608	Bubble
F#5	3297	Sd T8-5
G5	1608	Bubble
G#5	3297	Sd T8-5
A5	1544	Eery
A#5	3297	Sd T8-5
B5	1607	FX Chime
C6	1607	FX Chime

PDR 41 Garage Kit

Note	Wave Number	Wave Name
C0	2686	Bd Hard Long
C#0	2644	Bd T9-1
D0	2691	Bd Slimy
D#0	2688	Bd AnaHard
E0	2677	Bd Distortion4
F0	2698	Bd ElecComp3
F#0	2668	Bd Hip Deep
G0	2681	Bd FxHammer
G#0	2646	Bd T9-3
A0	2653	Bd T8-3
A#0	2684	Bd Sustain
B0	2667	Bd R&B2
C1	2648	Bd T9 Hd1
C#1	2691	Bd Slimy
D1	3293	Sd T8-1
D#1	3298	Sd T8 Rim
E1	3344	Sd Clappy
F1	2877	Sd Blues 3St
F#1	3410	HH Open 2St
G1	3614	HH Closed T8-2
G#1	3410	HH Open 2St
A1	3615	HH Open T8-2
A#1	3410	HH Open 2St
B1	3615	HH Open T8-2
C2	2424	Clap AnSm
C#2	3867	Crash2 St
D2	3971	Crash T9
D#2	3907	Ride1 St
E2	3975	Ride T9
F2	2441	Analog Click
F#2	2439	Claves T8
G2	2424	Clap AnSm
G#2	2423	Clap T9
A2	2432	Analog Shaker
A#2	2427	Conga T8
B2	2427	Conga T8
C3	3303	Sd AnCR
C#3	3195	Sd RockRoll St
D3	2080	Agogo Hi
D#3	3957	China1 RL
E3	1727	Hi Q2
F3	1726	Hi Q1
F#3	1710	Zap2
G3	1709	Zap1
G#3	1710	Zap2
A3	1737	Door Squeak
A#3	1769	Scratch Combi3
B3	1849	AcousticGtr FX27 St
C4	567	Play FX Mix
C#4	1751	Scratch Hi F
D4	192	Wurlf EP Hard+
D#4	192	Wurlf EP Hard+
E4	192	Wurlf EP Hard+
F4	1612	Resonance X-Fade
F#4	1554	Sonar1
G4	1606	Vox Drum
G#4	1606	Vox Drum
A4	1606	Vox Drum
A#4	3635	HH Open Syn
B4	3634	HH Closed Syn
C5	1387	Tri Wave
C#5	1387	Tri Wave
D5	1387	Tri Wave
D#5	1387	Tri Wave
E5	1387	Tri Wave
F5	1387	Tri Wave
F#5	1387	Tri Wave
G5	1387	Tri Wave
G#5	1387	Tri Wave
A5	1387	Tri Wave
A#5	1387	Tri Wave
B5	1387	Tri Wave
C6	1387	Tri Wave

PDR 42 Synth Pop Kit

Note	Wave Number	Wave Name
C0	2712	Bd HipHop8
C#0	2644	Bd T9-1
D0	2659	Bd Blip
D#0	2673	Bd Break Hard
E0	2699	Bd ElecFX1
F0	2701	Bd ElecGate
F#0	2700	Bd ElecFX2
G0	2675	Bd Distortion2
G#0	2690	Bd ThickSkin
A0	2697	Bd ElecComp2
A#0	2693	Bd Elec2
B0	2702	Bd ElecClick
C1	2702	Bd ElecClick
C#1	3292	Sd T9Rim
D1	3285	Sd Elec12
D#1	2423	Clap T9
E1	3281	Sd Elec8
F1	3855	Tom T9 Lo
F#1	3610	HH Closed T9
G1	3855	Tom T9 Lo
G#1	3611	HH Open T9
A1	3855	Tom T9 Lo
A#1	3611	HH Open T9
B1	3854	Tom T9 Hi
C2	3854	Tom T9 Hi
C#2	3971	Crash T9
D2	3854	Tom T9 Hi
D#2	3975	Ride T9
E2	3971	Crash T9
F2	3975	Ride T9
F#2	2436	Electric Tambourine2
G2	3971	Crash T9
G#2	2431	Electric Cowbell
A2	3971	Crash T9
A#2	2435	Electric Tambourine1
B2	3975	Ride T9
C3	1715	Electric Perc5
C#3	1714	Electric Perc4
D3	1722	Electric Perc12
D#3	1716	Electric Perc6
E3	1711	Electric Perc1
F3	1705	Bell FX1
F#3	1706	Bell FX2
G3	1765	Scratch Attack
G#3	1766	Scratch R&B
A3	2059	CabasaA 1-2
A#3	2057	Maracas Slur
B3	1724	Electric Perc14
C4	1725	Electric Perc15
C#4	1924	Shaker Hjp2
D4	1713	Electric Perc3
D#4	1717	Electric Perc7
E4	1718	Electric Perc8
F4	1719	Electric Perc9
F#4	1720	Electric Perc10
G4	1723	Electric Perc13
G#4	1944	Triangle Mute
A4	1943	Triangle Open
A#4	2438	Electric Maracas
B4	2440	Electric Triangle
C5	1721	Electric Perc11
C#5	3274	Sd Elec1
D5	3282	Sd Elec9
D#5	3283	Sd Elec10
E5	3284	Sd Elec11
F5	3275	Sd Elec2
F#5	3276	Sd Elec3
G5	3277	Sd Elec4
G#5	3278	Sd Elec5
A5	3279	Sd Elec6
A#5	3280	Sd Elec7
B5	2425	Electric Clap1
C6	2426	Electric Clap2

PDR 43 Orchestra Kit

Note	Wave Number	Wave Name
C0	2441	Analog Click
C#0	3209	Sd Brush Med L
D0	3219	Sd Brush Swir R
D#0	3209	Sd Brush Med L
E0	3222	Sd Brush SwirAtt R
F0	3256	Sd Orch Roll St
F#0	1935	Castanet1
G0	3224	Sd OrchA 1 St
G#0	1933	Stick1
A0	2621	Bd GranCasaA Mute St
A#0	3229	Sd OrchA 2 L
B0	2621	Bd GranCasaA Mute St
C1	2618	Bd GranCasaA Open St
C#1	3192	Sd Closed Rim R
D1	3225	Sd OrchA 2 St
D#1	1945	Hand Clap1 St
E1	3234	Sd OrchB 2 St
F1	251	Timpani1 Sw St
F#1	3372	HH Closed 1-4St
G1	251	Timpani1 Sw St
G#1	3397	HH Pedal 1-3 R
A1	251	Timpani1 Sw St
A#1	3408	HH Open 1-2St
B1	251	Timpani1 Sw St
C2	251	Timpani1 Sw St
C#2	3901	Hand Cymbal Open St
D2	251	Timpani1 Sw St
D#2	3907	Ride1 St
E2	3954	China1 St
F2	3935	Ride Cup1 St
F#2	1929	Tambourine1 Hit
G2	3904	Hand Cymbal Mute St
G#2	2110	Cowbell2
A2	3863	Crash1 St
A#2	1940	Vibraslap1
B2	3911	Ride2 St
C3	2007	Bongo1 Hi 1Fingr 1-2
C#3	2020	Bongo1 Lo 3Fingr 1-2
D3	1966	Conga1 Hi Tip
D#3	1970	Conga1 Hi Open 2
E3	2001	Tumba Open
F3	2033	Timbale1 Hi 1-3
F#3	2037	Timbale1 Lo 1-2
G3	2080	Agogo Hi
G#3	2081	Agogo Lo
A3	2059	CabasaA 1-2
A#3	2057	Maracas Slur
B3	2108	Whistle
C4	2108	Whistle
C#4	2084	Guiro Short
D4	2083	Guiro Long
D#4	2106	Claves1
E4	1939	Wood Block
F4	1939	Wood Block
F#4	2006	Cuica Hi
G4	2005	Cuica Lo
G#4	1944	Triangle Mute
A4	1943	Triangle Open
A#4	1917	ShakerA 1
B4	1954	Sleigh Bell1
C5	1957	Wind Chime
C#5	1939	Wood Block
D5	1939	Wood Block
D#5	1939	Wood Block
E5	1939	Wood Block
F5	1939	Wood Block
F#5	1939	Wood Block
G5	1939	Wood Block
G#5	1939	Wood Block
A5	1939	Wood Block
A#5	1939	Wood Block
B5	1939	Wood Block
C6	1939	Wood Block

PDR 44 Drum Machines Kit

Note	Wave Number	Wave Name
C0	2686	Bd Hard Long
C#0	2685	Bd TekPower
D0	2678	Bd Distortion5
D#0	2676	Bd Distortion3
E0	2674	Bd Distortion1
F0	2664	Bd D&B1
F#0	2659	Bd Blip
G0	2654	Bd AnSm
G#0	2652	Bd T8-2
A0	2653	Bd T8-3
A#0	2650	Bd T9 Hd3
B0	2645	Bd T9-2
C1	2646	Bd T9-3
C#1	3292	Sd T9Rim
D1	3286	Sd T9-1
D#1	2423	Clap T9
E1	3289	Sd T9-4
F1	3855	Tom T9 Lo
F#1	3610	HH Closed T9
G1	3855	Tom T9 Lo
G#1	3611	HH Open T9
A1	3855	Tom T9 Lo
A#1	3611	HH Open T9
B1	3855	Tom T9 Lo
C2	3855	Tom T9 Lo
C#2	3971	Crash T9
D2	2427	Conga T8
D#2	3975	Ride T9
E2	2427	Conga T8
F2	2441	Analog Click
F#2	2439	Claves T8
G2	2437	MaracasT8
G#2	2434	Tambourine AnCR
A2	2432	Analog Shaker
A#2	2428	Cowbell T8
B2	2430	Cowbell AnCR
C3	3293	Sd T8-1
C#3	3294	Sd T8-2
D3	3295	Sd T8-3
D#3	3303	Sd AnCR
E3	3307	Sd Jungle1
F3	3311	Sd D&B1
F#3	3318	Sd Hip1
G3	3315	Sd R&B1
G#3	3317	Sd R&B2
A3	3318	Sd Hip1
A#3	3346	Sd Wood
B3	3345	Sd Timbr
C4	3612	HH Closed T8-1
C#4	3613	HH Open T8-1
D4	3614	HH Closed T8-2
D#4	3615	HH Open T8-2
E4	3403	HH Pedal 3 R
F4	3416	HH Open 2R
F#4	3416	HH Open 2R
G4	3632	HH Closed Lo-Fi
G#4	3633	HH Open Lo-Fi
A4	3634	HH Closed Syn
A#4	3635	HH Open Syn
B4	2432	Analog Shaker
C5	2433	Tambourine RX5
C#5	2433	Tambourine RX5
D5	2431	Electric Cowbell
D#5	2427	Conga T8
E5	2440	Electric Triangle
F5	2439	Claves T8
F#5	2432	Analog Shaker
G5	2425	Electric Clap1
G#5	2426	Electric Clap2
A5	2434	Tambourine AnCR
A#5	2428	Cowbell T8
B5	2441	Analog Click
C6	2429	Cowbell RX11

PDR 45 Rock Multiple Kits

Note	Wave Number	Wave Name
C0	2487	Bd Normal St1-2
C#0	3174	Sd Rock Stick1 St
D0	2939	Sd Rock Open2 St
D#0	3195	Sd RockRoll St
E0	2930	Sd Rock Open1 St
F0	3647	Tom Low St
F#0	3420	HH Closed Foot St
G0	3647	Tom Low St
G#0	3395	HH Pedal 3 St
A0	3643	Tom Mid St
A#0	3410	HH Open 2St
B0	3639	Tom Hi St
C1	2523	Bd Rock2 St
C#1	3174	Sd Rock Stick1 St
D1	2939	Sd Rock Open2 St
D#1	1945	Hand Clap1 St
E1	2942	Sd Rock Mute2 St
F1	3663	Tom Rock Low St
F#1	3432	HH Closed Rock Sw St
G1	3663	Tom Rock Low St
G#1	3444	HH Pedal Rock Sw St
A1	3659	Tom Rock Mid St
A#1	3456	HH Open Rock Sw St
B1	3659	Tom Rock Mid St
C2	3655	Tom Rock Hi St
C#2	3867	Crash2 St
D2	3655	Tom Rock Hi St
D#2	3907	Ride1 St
E2	3954	China1 St
F2	3935	Ride Cup1 St
F#2	1927	Tambourine1 Sw
G2	3963	Splash1 St
G#2	2109	Cowbell1
A2	3867	Crash2 St
A#2	1917	ShakerA 1
B2	3907	Ride1 St
C3	2520	Bd Rock1 St
C#3	3177	Sd Rock Stick2 St
D3	2930	Sd Rock Open1 St
D#3	2423	Clap T9
E3	2933	Sd Rock Mute1 St
F3	3663	Tom Rock Low St
F#3	3432	HH Closed Rock Sw St
G3	3663	Tom Rock Low St
G#3	3452	HH Pedal Rock St
A3	3659	Tom Rock Mid St
A#3	3460	HH Half Open Rock St
B3	3659	Tom Rock Mid St
C4	3655	Tom Rock Hi St
C#4	3867	Crash2 St
D4	3655	Tom Rock Hi St
D#4	3912	Ride2 L
E4	3954	China1 St
F4	3935	Ride Cup1 St
F#4	1929	Tambourine1 Hit
G4	3963	Splash1 St
G#4	2116	Mambo Bell2
A4	3867	Crash2 St
A#4	2152	Shekere Down
B4	3913	Ride2 R
C5	2496	Bd Funk St1-2
C#5	3174	Sd Rock Stick1 St
D5	2936	Sd Rock Rim1 St
D#5	2948	Sd Rock Flam St
E5	2945	Sd Rock Rim2 St
F5	3651	Tom Floor St
F#5	3376	HH Closed 4St
G5	3647	Tom Low St
G#5	3395	HH Pedal 3 St
A5	3643	Tom Mid St
A#5	3428	HH Open2 St
B5	3643	Tom Mid St
C6	3639	Tom Hi St

PDR 46 HipHop Multiple Kits

Note	Wave Number	Wave Name
C0	2653	Bd T8-3
C#0	3298	Sd T8 Rim
D0	3358	Sd HipHop11
D#0	2423	Clap T9
E0	3356	Sd HipHop9
F0	2653	Bd T8-3
F#0	3627	HH Closed Tek
G0	2653	Bd T8-3
G#0	3628	HH Open Tek
A0	2653	Bd T8-3
A#0	3628	HH Open Tek
B0	2653	Bd T8-3
C1	2668	Bd Hip Deep
C#1	3183	Sd Hip Stick4
D1	3322	Sd Hip Rim1
D#1	2442	HipHop Clap1
E1	3319	Sd Hip2
F1	3856	Tom T8
F#1	3614	HH Closed T8-2
G1	3856	Tom T8
G#1	3620	HH Open AnCR
A1	3856	Tom T8
A#1	3613	HH Open T8-1
B1	3856	Tom T8
C2	3856	Tom T8
C#2	3971	Crash T9
D2	3856	Tom T8
D#2	3973	Crash Syn
E2	3973	Crash Syn
F2	3972	Crash T8
F#2	2433	Tambourine RX5
G2	3965	Splash1 R
G#2	2428	Cowbell T8
A2	3971	Crash T9
A#2	2430	Cowbell AnCR
B2	3975	Ride T9
C3	2668	Bd Hip Deep
C#3	3184	Sd Hip Stick5
D3	3323	Sd Hip Rim2
D#3	2443	HipHop Clap2
E3	3318	Sd Hip1
F3	3855	Tom T9 Lo
F#3	3616	HH Closed RX5
G3	3855	Tom T9 Lo
G#3	3619	HH Closed AnCR
A3	3855	Tom T9 Lo
A#3	3615	HH Open T8-2
B3	3855	Tom T9 Lo
C4	3854	Tom T9 Hi
C#4	3869	Crash2 R
D4	3854	Tom T9 Hi
D#4	3972	Crash T8
E4	3973	Crash Syn
F4	3972	Crash T8
F#4	1929	Tambourine1 Hit
G4	3956	China1 R
G#4	2429	Cowbell RX11
A4	3868	Crash2 L
A#4	2109	Cowbell1
B4	3913	Ride2 R
C5	2668	Bd Hip Deep
C#5	3369	Sd HipHop Rim4
D5	3351	Sd HipHop2
D#5	2443	HipHop Clap2
E5	3326	Sd Hip Rim5
F5	3861	Tom Dist Lo
F#5	3629	HH Closed Hip
G5	3861	Tom Dist Lo
G#5	3630	HH Pedal Hip
A5	3860	Tom Dist Hi
A#5	3631	HH Open Hip
B5	3860	Tom Dist Hi
C6	3860	Tom Dist Hi

PDR 47 Percussion Kit

Note	Wave Number	Wave Name
C0	2178	Wa Taiko
C#0	2220	Udu High
D0	2133	Djembe1 Open
D#0	1997	Quinto1 Open
E0	2221	Udu Low
F0	2219	Udu Finger
F#0	2220	Udu High
G0	2141	Tabla Bya
G#0	2077	Tmbourim Open
A0	2143	Tabla Mute
A#0	2142	Tabla Nah
B0	2143	Tabla Mute
C1	251	Timpani1 Sw St
C#1	1604	Hit Uhh
D1	2007	Bongo1 Hi 1Fingr 1-2
D#1	2423	Clap T9
E1	1944	Triangle Mute
F1	1943	Triangle Open
F#1	1935	Castanet1
G1	1935	Castanet1
G#1	1935	Castanet1
A1	2083	Guiro Long
A#1	2085	Guiro Swp
B1	2084	Guiro Short
C2	1940	Vibraslap1
C#2	2106	Claves1
D2	2439	Claves T8
D#2	2005	Cuica Lo
E2	2006	Cuica Hi
F2	2037	Timbale1 Lo 1-2
F#2	1939	Wood Block
G2	2039	Timbale1 Lo 2
G#2	1939	Wood Block
A2	2033	Timbale1 Hi 1-3
A#2	2119	ChaCha Bell
B2	2035	Timbale1 Hi 2
C3	2042	Timbale1 Paila L
C#3	2042	Timbale1 Paila L
D3	2041	Timbale1 Paila H
D#3	2115	Mambo Bell1
E3	2020	Bongo1 Lo 3Fingr 1-2
F3	2020	Bongo1 Lo 3Fingr 1-2
F#3	1952	Handbell L
G3	2007	Bongo1 Hi 1Fingr 1-2
G#3	1953	Handbell H
A3	2007	Bongo1 Hi 1Fingr 1-2
A#3	2081	Agogo Lo
B3	2080	Agogo Hi
C4	1967	Conga1 Hi Heel
C#4	1966	Conga1 Hi Tip
D4	2002	Tumba Slap
D#4	2057	Maracas Slur
E4	2001	Tumba Open
F4	1967	Conga1 Hi Heel
F#4	1966	Conga1 Hi Tip
G4	1972	Conga1 Hi Slap Open
G#4	1917	ShakerA 1
A4	1970	Conga1 Hi Open 2
A#4	2060	CabasaA 1
B4	2059	CabasaA 1-2
C5	1967	Conga1 Hi Heel
C#5	1966	Conga1 Hi Tip
D5	1998	Quinto1 Slap
D#5	1917	ShakerA 1
E5	1999	Quinto2 Open
F5	2067	Caxixi 1-2
F#5	1928	Tambourine1 Shake
G5	1929	Tambourine1 Hit
G#5	1927	Tambourine1 Sw
A5	1929	Tambourine1 Hit
A#5	1954	Sleigh Bell1
B5	2108	Whistle
C6	2108	Whistle

PDR 48 Latin Percussion Kit

Note	Wave Number	Wave Name
C0	2514	Bd L Son St
C#0	3177	Sd Rock Stick2 St
D0	2821	Sd Funk St1/3
D#0	3867	Crash2 St
E0	3963	Splash1 St
F0	3647	Tom Low St
F#0	3372	HH Closed 1-4St
G0	3647	Tom Low St
G#0	3395	HH Pedal 3 St
A0	3643	Tom Mid St
A#0	3410	HH Open 2St
B0	3639	Tom Hi St
C1	1966	Conga1 Hi Tip
C#1	1967	Conga1 Hi Heel
D1	2002	Tumba Slap
D#1	2106	Claves1
E1	2001	Tumba Open
F1	1966	Conga1 Hi Tip
F#1	1967	Conga1 Hi Heel
G1	1972	Conga1 Hi Slap Open
G#1	1952	Handbell L
A1	1970	Conga1 Hi Open 2
A#1	1953	Handbell H
B1	2115	Mambo Bell1
C2	1966	Conga1 Hi Tip
C#2	1967	Conga1 Hi Heel
D2	1998	Quinto1 Slap
D#2	2119	ChaCha Bell
E2	1997	Quinto1 Open
F2	2020	Bongo1 Lo 3Fingr 1-2
F#2	2007	Bongo1 Hi 1Fingr 1-2
G2	2010	Bongo1 Hi 3Fingr 1-2
G#2	2038	Timbale1 Lo 1
A2	2042	Timbale1 Paila L
A#2	2034	Timbale1 Hi 1
B2	2041	Timbale1 Paila H
C3	1939	Wood Block
C#3	1939	Wood Block
D3	2152	Shekere Down
D#3	2153	Shekere Up
E3	2154	Shekere Slap
F3	2057	Maracas Slur
F#3	2058	Maracas Staccato
G3	2083	Guiro Long
G#3	2085	Guiro Swp
A3	2084	Guiro Short
A#3	2091	Surdo1 Mute
B3	2090	Surdo1 Open
C4	2075	Pandeiro Tip
C#4	2076	Pandeiro Heel
D4	2074	Pandeiro Thump
D#4	2073	Pandeiro Open
E4	2078	Tmbourim Finger
F4	2077	Tmbourim Open
F#4	2079	Tmbourim Mute
G4	2082	Agogo Lo Tap
G#4	2081	Agogo Lo
A4	2080	Agogo Hi
A#4	1943	Triangle Open
B4	1944	Triangle Mute
C5	1918	ShakerA 2
C#5	1917	ShakerA 1
D5	1919	ShakerA 3
D#5	2060	CabasaA 1
E5	2061	CabasaA 2
F5	2068	Caxixi 1
F#5	2069	Caxixi 2
G5	2005	Cuica Lo
G#5	2006	Cuica Hi
A5	2108	Whistle
A#5	2108	Whistle
B5	1940	Vibraslap1
C6	1957	Wind Chime

PDR 49 Guitar/Bass FX Kit

Note	Wave Number	Wave Name
C0	1889	Acoustic Bass FX06
C#0	1889	Acoustic Bass FX06
D0	567	Play FX Mix
D#0	566	Power Chord Mono
E0	566	Power Chord Mono
F0	1884	Acoustic Bass FX01
F#0	1774	AcousticGtr FX02 St
G0	1897	Electric Bass FX 05
G#0	1908	Electric Bass FX 16
A0	1893	Electric Bass FX 01
A#0	1866	ElectricGtr FX06
B0	1909	Electric Bass FX 17
C1	1896	Electric Bass FX 04
C#1	1902	Electric Bass FX 10
D1	567	Play FX Mix
D#1	1903	Electric Bass FX 11
E1	567	Play FX Mix
F1	1910	Electric Bass FX 18
F#1	1908	Electric Bass FX 16
G1	1910	Electric Bass FX 18
G#1	1909	Electric Bass FX 17
A1	1910	Electric Bass FX 18
A#1	1873	ElectricGtr FX13
B1	1910	Electric Bass FX 18
C2	1910	Electric Bass FX 18
C#2	1855	AcousticGtr FX29 St
D2	1910	Electric Bass FX 18
D#2	1903	Electric Bass FX 11
E2	1855	AcousticGtr FX29 St
F2	1903	Electric Bass FX 11
F#2	1902	Electric Bass FX 10
G2	1855	AcousticGtr FX29 St
G#2	567	Play FX Mix
A2	1855	AcousticGtr FX29 St
A#2	1905	Electric Bass FX 13
B2	1903	Electric Bass FX 11
C3	1902	Electric Bass FX 10
C#3	1902	Electric Bass FX 10
D3	1894	Electric Bass FX 02
D#3	1900	Electric Bass FX 08
E3	1910	Electric Bass FX 18
F3	1892	Acoustic Bass FX09
F#3	1892	Acoustic Bass FX09
G3	1890	Acoustic Bass FX07
G#3	1890	Acoustic Bass FX07
A3	1889	Acoustic Bass FX06
A#3	1892	Acoustic Bass FX09
B3	567	Play FX Mix
C4	567	Play FX Mix
C#4	1914	Electric Bass FX 22
D4	1786	AcousticGtr FX06 St
D#4	1908	Electric Bass FX 16
E4	1908	Electric Bass FX 16
F4	1895	Electric Bass FX 03
F#4	567	Play FX Mix
G4	567	Play FX Mix
G#4	1903	Electric Bass FX 11
A4	1909	Electric Bass FX 17
A#4	1774	AcousticGtr FX02 St
B4	1906	Electric Bass FX 14
C5	1881	ElectricGtr FX21
C#5	1880	ElectricGtr FX20
D5	1879	ElectricGtr FX19
D#5	567	Play FX Mix
E5	567	Play FX Mix
F5	567	Play FX Mix
F#5	567	Play FX Mix
G5	667	Electric Bass FX
G#5	1914	Electric Bass FX 22
A5	1897	Electric Bass FX 05
A#5	1907	Electric Bass FX 15
B5	667	Electric Bass FX
C6	1911	Electric Bass FX 19

PDR 50 Wacko Kit

Note	Wave Number	Wave Name
C0	1893	Electric Bass FX 01
C#0	1710	Zap2
D0	3624	HH Pedal D&B
D#0	1946	Hand Clap1 L
E0	1759	Scratch Vo F
F0	1707	IndusTom
F#0	3346	Sd Wood
G0	1707	IndusTom
G#0	3336	Sd ClapAna
A0	1707	IndusTom
A#0	3342	Sd FM Rim
B0	2643	Bd FX Gate
C1	2681	Bd FxHammer
C#1	1972	Conga1 Hi Slap Open
D1	3341	Sd FM
D#1	1946	Hand Clap1 L
E1	3345	Sd Timbr
F1	3858	Tom Syn2
F#1	3634	HH Closed Syn
G1	3858	Tom Syn2
G#1	3635	HH Open Syn
A1	3858	Tom Syn2
A#1	3635	HH Open Syn
B1	3858	Tom Syn2
C2	3858	Tom Syn2
C#2	3469	HH Open Mono
D2	1554	Sonar1
D#2	3613	HH Open T8-1
E2	3469	HH Open Mono
F2	3948	Ride Cup2 L
F#2	1954	Sleigh Bell1
G2	3615	HH Open T8-2
G#2	1612	Resonance X-Fade
A2	3868	Crash2 L
A#2	1747	RainLoop
B2	3949	Ride Cup2 R
C3	1548	AirHose L
C#3	1548	AirHose L
D3	2220	Udu High
D#3	1480	Mg Bass2
E3	1482	Mg Bass3
F3	1889	Acoustic Bass FX06
F#3	1889	Acoustic Bass FX06
G3	2081	Agogo Lo
G#3	2081	Agogo Lo
A3	3638	HH Open Human
A#3	1728	Vox Hit Rev
B3	1726	Hi Q1
C4	1726	Hi Q1
C#4	1660	LFO Seq
D4	1660	LFO Seq
D#4	1541	BellAir
E4	1596	HH Hit
F4	1596	HH Hit
F#4	1551	Ooh Feedback
G4	1551	Ooh Feedback
G#4	1553	Mind Bell
A4	1704	Glass
A#4	1734	Swarm
B4	1732	FxGun2
C5	1609	Lektronica
C#5	567	Play FX Mix
D5	1745	Gunshot
D#5	1736	Police
E5	1703	Ripper
F5	567	Play FX Mix
F#5	1730	Tape Rewind
G5	1731	FxGun1
G#5	1729	Bomb
A5	1710	Zap2
A#5	1708	Noise Burst
B5	1600	Stab Giant
C6	1599	Stab Orchestra

PDR 51 Wood Bits Kit

Note	Wave Number	Wave Name
C0	2439	Claves T8
C#0	3186	Sd Hip Stick6 L
D0	2083	Guiro Long
D#0	3187	Sd Hip Stick6 R
E0	2083	Guiro Long
F0	1807	AcousticGtr FX13 St
F#0	1935	Castanet1
G0	1903	Electric Bass FX 11
G#0	1933	Stick1
A0	1900	Electric Bass FX 08
A#0	1899	Electric Bass FX 07
B0	3854	Tom T9 Hi
C1	1909	Electric Bass FX 17
C#1	3194	Sd Closed Rim3
D1	1934	Stick2
D#1	2083	Guiro Long
E1	1934	Stick2
F1	2090	Surdo1 Open
F#1	3302	Sd AnSm Rim
G1	2090	Surdo1 Open
G#1	2424	Clap AnSm
A1	2090	Surdo1 Open
A#1	1940	Vibraslap1
B1	2090	Surdo1 Open
C2	2090	Surdo1 Open
C#2	1740	Seashore
D2	2090	Surdo1 Open
D#2	3177	Sd Rock Stick2 St
E2	1746	Applause
F2	3175	Sd Rock Stick1 L
F#2	1928	Tambourine1 Shake
G2	1740	Seashore
G#2	1939	Wood Block
A2	1746	Applause
A#2	1739	Helicopter
B2	3179	Sd Rock Stick2 R
C3	1972	Conga1 Hi Slap Open
C#3	1972	Conga1 Hi Slap Open
D3	1935	Castanet1
D#3	1935	Castanet1
E3	1939	Wood Block
F3	2042	Timbale1 Paila L
F#3	2042	Timbale1 Paila L
G3	2081	Stick1
G#3	1934	Stick2
A3	2067	Caxixi 1-2
A#3	2069	Caxixi 2
B3	1737	Door Squeak
C4	1737	Door Squeak
C#4	2084	Guiro Short
D4	2083	Guiro Long
D#4	2106	Claves1
E4	1939	Wood Block
F4	1939	Wood Block
F#4	1737	Door Squeak
G4	1737	Door Squeak
G#4	1939	Wood Block
A4	2106	Claves1
A#4	1737	Door Squeak
B4	1946	Hand Clap1 L
C5	2119	ChaCha Bell
C#5	2939	Sd Rock Open2 St
D5	2663	Bd Jungle3
D#5	1998	Quinto1 Slap
E5	2532	Bd Room2
F5	2511	Bd H Son St
F#5	3172	Sd Heavy
G5	2090	Surdo1 Open
G#5	3174	Sd Rock Stick1 St
A5	2691	Bd Slimy
A#5	3167	Sd Gate1
B5	2517	Bd Funk Son St
C6	2642	Bd Gate

PDR 52 Metal Bits Kit

Note	Wave Number	Wave Name
C0	2428	Cowbell T8
C#0	3386	HH Closed 4R
D0	3949	Ride Cup2 R
D#0	3635	HH Open Syn
E0	3948	Ride Cup2 L
F0	3935	Ride Cup1 St
F#0	1394	FM Metal2
G0	3907	Ride1 St
G#0	1717	Electric Perc7
A0	2110	Cowbell2
A#0	3373	HH Closed 1St
B0	2119	ChaCha Bell
C1	2110	Cowbell2
C#1	3634	HH Closed Syn
D1	3628	HH Open Tek
D#1	3614	HH Closed T8-2
E1	3616	HH Closed RX5
F1	2110	Cowbell2
F#1	3613	HH Open T8-1
G1	2110	Cowbell2
G#1	3634	HH Closed Syn
A1	2110	Cowbell2
A#1	3635	HH Open Syn
B1	2110	Cowbell2
C2	2110	Cowbell2
C#2	3637	HH Open FX
D2	2110	Cowbell2
D#2	3935	Ride Cup1 St
E2	3620	HH Open AnCR
F2	3935	Ride Cup1 St
F#2	1927	Tambourine1 Sw
G2	3637	HH Open FX
G#2	2116	Mambo Bell2
A2	3637	HH Open FX
A#2	1954	Sleigh Bell1
B2	3951	Ride Mono
C3	146	Brite Piano
C#3	146	Brite Piano
D3	320	Tubular Bell1
D#3	322	Bell
E3	325	Brass Bell
F3	2041	Timbale1 Paila H
F#3	2042	Timbale1 Paila L
G3	322	Bell
G#3	322	Bell
A3	3373	HH Closed 1St
A#3	3620	HH Open AnCR
B3	1541	BellAir
C4	1607	FX Chime
C#4	3463	HH Open Rock L
D4	1609	Lektronica
D#4	2081	Agogo Lo
E4	2109	Cowbell1
F4	2110	Cowbell2
F#4	1546	Hi-Lo
G4	1546	Hi-Lo
G#4	1944	Triangle Mute
A4	1943	Triangle Open
A#4	1607	FX Chime
B4	1954	Sleigh Bell1
C5	1957	Wind Chime
C#5	326	Small Bell
D5	326	Small Bell
D#5	325	Brass Bell
E5	329	Hibashi
F5	146	Brite Piano
F#5	3169	Sd LdwHmono
G5	146	Brite Piano
G#5	3170	Sd BreakRim
A5	336	Gamelan2
A#5	2219	Udu Finger
B5	327	Finger Cymbal
C6	322	Bell

PDR 53 Hands Kit

Note	Wave Number	Wave Name
C0	2143	Tabla Mute
C#0	3205	Sd Brush Soft St
D0	3217	Sd Brush Swir St
D#0	3208	Sd Brush Med St
E0	3220	Sd Brush SwirAtt St
F0	1855	AcousticGtr FX29 St
F#0	1934	Stick2
G0	2074	Pandeiro Thump
G#0	2143	Tabla Mute
A0	1908	Electric Bass FX 16
A#0	1819	AcousticGtr FX17 St
B0	2144	Tabla Combi
C1	2178	Wa Taiko
C#1	1998	Quinto1 Slap
D1	3208	Sd Brush Med St
D#1	1945	Hand Clap1 St
E1	2833	Sd Funk Ay St
F1	2221	Udu Low
F#1	2143	Tabla Mute
G1	2221	Udu Low
G#1	2141	Tabla Bya
A1	2220	Udu High
A#1	2142	Tabla Nah
B1	2220	Udu High
C2	2219	Udu Finger
C#2	3913	Ride2 R
D2	2219	Udu Finger
D#2	3935	Ride Cup1 St
E2	3953	Ride Cup Mono2
F2	3935	Ride Cup1 St
F#2	1929	Tambourine1 Hit
G2	3935	Ride Cup1 St
G#2	2109	Cowbell1
A2	3951	Ride Mono
A#2	1940	Vibraslap1
B2	3912	Ride2 L
C3	2007	Bongo1 Hi 1Fingr 1-2
C#3	2020	Bongo1 Lo 3Fingr 1-2
D3	1966	Conga1 Hi Tip
D#3	1972	Conga1 Hi Slap Open
E3	1970	Conga1 Hi Open 2
F3	2033	Timbale1 Hi 1-3
F#3	2037	Timbale1 Lo 1-2
G3	2080	Agogo Hi
G#3	2081	Agogo Lo
A3	2078	Tmbourim Finger
A#3	2078	Tmbourim Finger
B3	1946	Hand Clap1 L
C4	1946	Hand Clap1 L
C#4	2083	Guero Long
D4	2083	Guero Long
D#4	2219	Udu Finger
E4	2141	Tabla Bya
F4	1966	Conga1 Hi Tip
F#4	2220	Udu High
G4	2220	Udu High
G#4	2219	Udu Finger
A4	327	Finger Cymbal
A#4	2143	Tabla Mute
B4	1954	Sleigh Bell1
C5	1957	Wind Chime
C#5	1972	Conga1 Hi Slap Open
D5	2003	Tumba Tip
D#5	2003	Tumba Tip
E5	1900	Electric Bass FX 08
F5	2003	Tumba Tip
F#5	1893	Electric Bass FX 01
G5	2001	Tumba Open
G#5	1898	Electric Bass FX 06
A5	1780	AcousticGtr FX04 St
A#5	2221	Udu Low
B5	2134	Djembe1 Combi
C6	2002	Tumba Slap

PDR 54 Scratches

Note	Wave Number	Wave Name
C0	1748	Scratch H
C#0	1749	Scratch L
D0	1750	Scratch Down
D#0	1751	Scratch Hi F
E0	1752	Scratch Hi R
F0	1753	Scratch Lo F
F#0	1754	Scratch Lo R
G0	1755	Scratch Bd F
G#0	1756	Scratch Bd R
A0	1757	Scratch Sd F
A#0	1758	Scratch Sd R
B0	1759	Scratch Vo F
C1	1748	Scratch H
C#1	1749	Scratch L
D1	1750	Scratch Down
D#1	1751	Scratch Hi F
E1	1752	Scratch Hi R
F1	1753	Scratch Lo F
F#1	1754	Scratch Lo R
G1	1755	Scratch Bd F
G#1	1756	Scratch Bd R
A1	1757	Scratch Sd F
A#1	1758	Scratch Sd R
B1	1759	Scratch Vo F
C2	1760	Scratch Vo R
C#2	1761	Scratch Stop
D2	1762	Scratch Spin
D#2	1763	Scratch Hip
E2	1764	Scratch Hip2
F2	1767	Scratch Combi
F#2	1768	Scratch Combi2
G2	1769	Scratch Combi3
G#2	1770	Scratch Combi4
A2	1748	Scratch H
A#2	1749	Scratch L
B2	1750	Scratch Down
C3	1751	Scratch Hi F
C#3	1752	Scratch Hi R
D3	1753	Scratch Lo F
D#3	1754	Scratch Lo R
E3	1755	Scratch Bd F
F3	1756	Scratch Bd R
F#3	1757	Scratch Sd F
G3	1758	Scratch Sd R
G#3	1759	Scratch Vo F
A3	1760	Scratch Vo R
A#3	1761	Scratch Stop
B3	1762	Scratch Spin
C4	1763	Scratch Hip
C#4	1764	Scratch Hip2
D4	1767	Scratch Combi
D#4	1768	Scratch Combi2
E4	1769	Scratch Combi3
F4	1770	Scratch Combi4
F#4	1748	Scratch H
G4	1749	Scratch L
G#4	1750	Scratch Down
A4	1751	Scratch Hi F
A#4	1752	Scratch Hi R
B4	1753	Scratch Lo F
C5	1754	Scratch Lo R
C#5	1755	Scratch Bd F
D5	1756	Scratch Bd R
D#5	1757	Scratch Sd F
E5	1758	Scratch Sd R
F5	1759	Scratch Vo F
F#5	1760	Scratch Vo R
G5	1761	Scratch Stop
G#5	1762	Scratch Spin
A5	1763	Scratch Hip
A#5	1764	Scratch Hip2
B5	1767	Scratch Combi
C6	1768	Scratch Combi2

PDR 55 Acoustic Snares

Note	Wave Number	Wave Name
C0	2804	Sd Normal 1St
C#0	2805	Sd Normal 2St
D0	2806	Sd Normal 3St
D#0	2807	Sd Normal 4St
E0	2822	Sd Funk 1St
F0	2823	Sd Funk 2St
F#0	2824	Sd Funk 3St
G0	2833	Sd Funk Ay St
G#0	2840	Sd Basic 1St
A0	2841	Sd Basic 2St
A#0	2842	Sd Basic 3St
B0	2857	Sd SonA 1St
C1	2858	Sd SonA 2St
C#1	2859	Sd SonA 3St
D1	2860	Sd SonA 4St
D#1	2875	Sd Blues 1St
E1	2876	Sd Blues 2St
F1	2877	Sd Blues 3St
F#1	2890	Sd BluesHeart 1St
G1	2891	Sd BluesHeart 2St
G#1	2892	Sd BluesHeart 3St
A1	2907	Sd Tight 1St
A#1	2908	Sd Tight 2St
B1	2909	Sd Tight 3St
C2	2910	Sd Tight 4St
C#2	2922	Sd Hip 1St
D2	2923	Sd Hip 2St
D#2	2930	Sd Rock Open1 St
E2	2933	Sd Rock Mute1 St
F2	2936	Sd Rock Rim1 St
F#2	2939	Sd Rock Open2 St
G2	2942	Sd Rock Mute2 St
G#2	2945	Sd Rock Rim2 St
A2	2948	Sd Rock Flam St
A#2	2930	Sd Rock Open1 St
B2	2933	Sd Rock Mute1 St
C3	2936	Sd Rock Rim1 St
C#3	2939	Sd Rock Open2 St
D3	2942	Sd Rock Mute2 St
D#3	2945	Sd Rock Rim2 St
E3	2948	Sd Rock Flam St
F3	2806	Sd Normal 3St
F#3	2833	Sd Funk Ay St
G3	2842	Sd Basic 3St
G#3	2859	Sd SonA 3St
A3	2892	Sd BluesHeart 3St
A#3	2909	Sd Tight 3St
B3	2918	Sd Bid St1-4
C4	2738	Sd Soul St1-4
D4	2758	Sd Strong St1-4
D#4	2778	Sd Rng St1-4
E4	2955	Sd Mid Rim
F4	2956	Sd Ambience
F#4	3167	Sd Gate1
G4	3169	Sd LdwHMMono
G#4	3170	Sd BreakRim
A4	3171	Sd Dry
A#4	3172	Sd Heavy
B4	3173	Sd GM
C5	2978	Sd PowerB 1-5St
C#5	3002	Sd PowerC 1-5St
D5	3026	Sd PowerD 1-4St
D#5	3173	Sd GM
E5	3205	Sd Brush Soft St
F5	3208	Sd Brush Med St
F#5	3211	Sd Brush vari St
G5	3220	Sd Brush SwirAtt St
G#5	3224	Sd OrchA 1 St
A5	3232	Sd OrchB 1-2 St
A#5	3256	Sd Orch Roll St
B5	3225	Sd OrchA 2 St
C6	3208	Sd Brush Med St

PDR 56 GroupedStereo Snares

Note	Wave Number	Wave Name
C0	2798	Sd Normal St1-4
C#0	2799	Sd Normal St1-3
D0	2800	Sd Normal St2-4
D#0	2801	Sd Normal St1-2
E0	2802	Sd Normal St2-3
F0	2803	Sd Normal St3-4
F#0	2804	Sd Normal 1St
G0	2805	Sd Normal 2St
G#0	2806	Sd Normal 3St
A0	2807	Sd Normal 4St
A#0	2818	Sd Funk St1-3
B0	2819	Sd Funk St1-2
C1	2820	Sd Funk St2-3
C#1	2821	Sd Funk St1/3
D1	2822	Sd Funk 1St
D#1	2823	Sd Funk 2St
E1	2824	Sd Funk 3St
F1	2833	Sd Funk Ay St
F#1	2836	Sd Basic St1-3
G1	2837	Sd Basic St1-2
G#1	2838	Sd Basic St2-3
A1	2839	Sd Basic St1/3
A#1	2840	Sd Basic 1St
B1	2841	Sd Basic 2St
C2	2842	Sd Basic 3St
C#2	2851	Sd SonA St1-4
D2	2852	Sd SonA St1-3
D#2	2853	Sd SonA St2-4
E2	2854	Sd SonA St1-2
F2	2855	Sd SonA St2-3
F#2	2856	Sd SonA St3-4
G2	2857	Sd SonA 1St
G#2	2858	Sd SonA 2St
A2	2859	Sd SonA 3St
A#2	2860	Sd SonA 4St
B2	2871	Sd Blues St1-3
C3	2872	Sd Blues St1-2
C#3	2873	Sd Blues St2-3
D3	2874	Sd Blues St1/3
D#3	2875	Sd Blues 1St
E3	2876	Sd Blues 2St
F3	2877	Sd Blues 3St
F#3	2886	Sd BluesHeart St1-3
G3	2887	Sd BluesHeart St1-2
G#3	2888	Sd BluesHeart St2-3
A3	2889	Sd BluesHeart St1/3
A#3	2890	Sd BluesHeart 1St
B3	2891	Sd BluesHeart 2St
C4	2892	Sd BluesHeart 3St
C#4	2901	Sd Tight St1-4
D4	2902	Sd Tight St1-3
D#4	2903	Sd Tight St2-4
E4	2904	Sd Tight St1-2
F4	2905	Sd Tight St2-3
F#4	2906	Sd Tight St3-4
G4	2907	Sd Tight 1St
G#4	2908	Sd Tight 2St
A4	2909	Sd Tight 3St
A#4	2910	Sd Tight 4St
B4	2963	Sd PowerA 1St
C5	2966	Sd PowerA 2St
C#5	2969	Sd PowerA 3St
D5	2972	Sd PowerA 4St
D#5	2975	Sd PowerA 5St
E5	2984	Sd PowerB 1St
F5	2987	Sd PowerB 2St
F#5	2990	Sd PowerB 3St
G5	2993	Sd PowerB 4St
G#5	2996	Sd PowerB 5St
A5	3002	Sd PowerC 1-5St
A#5	3026	Sd PowerD 1-4St
B5	2871	Sd Blues St1-3
C6	2886	Sd BluesHeart St1-3

PDR 57 All Kicks

Note	Wave Number	Wave Name
C0	2487	Bd Normal St1-2
C#0	2460	Bd Snap 1-2
D0	2470	Bd Tight 1
D#0	2490	Bd Normal L1-2
E0	2496	Bd Funk St1-2
F0	2478	Bd Ambience 1-2
F#0	2498	Bd Funk 2St
G0	2505	Bd High St
G#0	2508	Bd Low St
A0	2511	Bd H Son St
A#0	2514	Bd L Son St
B0	2517	Bd Funk Son St
C1	2520	Bd Rock1 St
C#1	2523	Bd Rock2 St
D1	2526	Bd Dry1
D#1	2527	Bd Dry2
E1	2528	Bd Pop
F1	2529	Bd Var1
F#1	2530	Bd Var2
G1	2531	Bd Room1
G#1	2532	Bd Room2
A1	2533	Bd Room3
A#1	2642	Bd Gate
B1	2643	Bd FX Gate
C2	2546	Bd PowerA 1-2St
C#2	2555	Bd PowerB 1-2St
D2	2543	Bd FK Jazz St
D#2	2647	Bd T9-4
E2	2648	Bd T9 Hd1
F2	2649	Bd T9 Hd2
F#2	2650	Bd T9 Hd3
G2	2651	Bd T8-1
G#2	2652	Bd T8-2
A2	2653	Bd T8-3
A#2	2654	Bd AnSm
B2	2655	Bd AnCR
C3	2657	Bd Human1
C#3	2658	Bd Human2
D3	2659	Bd Blip
D#3	2660	Bd BlpHd
E3	2661	Bd Jungle1
F3	2662	Bd Jungle2
F#3	2663	Bd Jungle3
G3	2664	Bd D&B1
G#3	2665	Bd D&B2
A3	2666	Bd R&B1
A#3	2667	Bd R&B2
B3	2668	Bd Hip Deep
C4	2669	Bd Break Deep
C#4	2670	Bd Break1
D4	2671	Bd Break2
D#4	2672	Bd Break Heavy
E4	2673	Bd Break Hard
F4	2674	Bd Distortion1
F#4	2675	Bd Distortion2
G4	2676	Bd Distortion3
G#4	2677	Bd Distortion4
A4	2678	Bd Distortion5
A#4	2679	Bd Distortion RM
B4	2680	Bd +HH
C5	2681	Bd FxHammer
C#5	2682	Bd ZapHard
D5	2683	Bd ZapMid
D#5	2684	Bd Sustain
E5	2685	Bd TekPower
F5	2686	Bd Hard Long
F#5	2687	Bd Analog Tight
G5	2688	Bd AnaHard
G#5	2689	Bd Lo-Fi
A5	2690	Bd ThickSkin
A#5	2691	Bd Slimy
B5	2712	Bd HipHop8
C6	2714	Bd HipHop10

PDR 58 Dance Kicks

Note	Wave Number	Wave Name
C0	2644	Bd T9-1
C#0	2644	Bd T9-1
D0	2645	Bd T9-2
D#0	2646	Bd T9-3
E0	2646	Bd T9-3
F0	2647	Bd T9-4
F#0	2648	Bd T9 Hd1
G0	2649	Bd T9 Hd2
G#0	2650	Bd T9 Hd3
A0	2650	Bd T9 Hd3
A#0	2686	Bd Hard Long
B0	2655	Bd AnCR
C1	2644	Bd T9-1
C#1	2645	Bd T9-2
D1	2646	Bd T9-3
D#1	2647	Bd T9-4
E1	2648	Bd T9 Hd1
F1	2649	Bd T9 Hd2
F#1	2650	Bd T9 Hd3
G1	2651	Bd T8-1
G#1	2652	Bd T8-2
A1	2653	Bd T8-3
A#1	2692	Bd Elec1
B1	2655	Bd AnCR
C2	2657	Bd Human1
C#2	2692	Bd Elec1
D2	2659	Bd Blip
D#2	2660	Bd BlpHd
E2	2694	Bd Elec3
F2	2699	Bd ElecFX1
F#2	2700	Bd ElecFX2
G2	2701	Bd ElecGate
G#2	2702	Bd ElecClick
A2	2703	Bd ElecPower1
A#2	2667	Bd R&B2
B2	2668	Bd Hip Deep
C3	2669	Bd Break Deep
C#3	2670	Bd Break1
D3	2704	Bd ElecPower2
D#3	2672	Bd Break Heavy
E3	2673	Bd Break Hard
F3	2674	Bd Distortion1
F#3	2675	Bd Distortion2
G3	2676	Bd Distortion3
G#3	2677	Bd Distortion4
A3	2678	Bd Distortion5
A#3	2693	Bd Elec2
B3	2696	Bd ElecComp1
C4	2681	Bd FxHammer
C#4	2682	Bd ZapHard
D4	2683	Bd ZapMid
D#4	2684	Bd Sustain
E4	2685	Bd TekPower
F4	2686	Bd Hard Long
F#4	2687	Bd Analog Tight
G4	2688	Bd AnaHard
G#4	2697	Bd ElecComp2
A4	2698	Bd ElecComp3
A#4	2691	Bd Slimy
B4	2642	Bd Gate
C5	2643	Bd FX Gate
C#5	2705	Bd HipHop1
D5	2706	Bd HipHop2
D#5	2707	Bd HipHop3
E5	2708	Bd HipHop4
F5	2709	Bd HipHop5
F#5	2710	Bd HipHop6
G5	2711	Bd HipHop7
G#5	2712	Bd HipHop8
A5	2713	Bd HipHop9
A#5	2714	Bd HipHop10
B5	2686	Bd Hard Long
C6	2687	Bd Analog Tight

PDR 59 Arabic Mixed Kit

Note	Wave Number	Wave Name
C0	1957	Wind Chime
C#0	3205	Sd Brush Soft St
D0	3217	Sd Brush Swir St
D#0	3208	Sd Brush Med St
E0	3220	Sd Brush SwirAtt St
F0	3201	Sd LiveRoll St
F#0	1935	Castanet1
G0	2804	Sd Normal 1St
G#0	1933	Stick1
A0	2645	Bd T9-2
A#0	2836	Sd Basic St1-3
B0	2505	Bd High St
C1	2487	Bd Normal St1-2
C#1	2818	Sd Funk St1-3
D1	2718	Sd Bld St1-4
D#1	1945	Hand Clap1 St
E1	2738	Sd Soul St1-4
F1	3663	Tom Rock Low St
F#1	3372	HH Closed 1-4St
G1	3659	Tom Rock Mid St
G#1	3392	HH Pedal 1-3St
A1	3651	Tom Floor St
A#1	3408	HH Open 1-2St
B1	3647	Tom Low St
C2	3643	Tom Mid St
C#2	3867	Crash2 St
D2	3639	Tom Hi St
D#2	3408	HH Open 1-2St
E2	3977	Reverse Cymbal
F2	2037	Timbale1 Lo 1-2
F#2	1970	Conga1 Hi Open 2
G2	2033	Timbale1 Hi 1-3
G#2	1972	Conga1 Hi Slap Open
A2	1927	Tambourine1 Sw
A#2	2001	Tumba Open
B2	2109	Cowbell1
C3	2106	Claves1
C#3	2007	Bongo1 Hi 1Fingr 1-2
D3	1939	Wood Block
D#3	2020	Bongo1 Lo 3Fingr 1-2
E3	1939	Wood Block
F3	2145	Dohol Low
F#3	2059	CabasaA 1-2
G3	2146	Dohol High
G#3	1917	ShakerA 1
A3	1935	Castanet1
A#3	2056	Maracas Sw
B3	1935	Castanet1
C4	2230	Twaisat3
C#4	2228	Twaisat1
D4	2229	Twaisat2
D#4	2231	Twaisat4
E4	2231	Twaisat4
F4	2204	Small Tabla Dom
F#4	2223	Barasim Dom
G4	2205	Small Tabla Snap
G#4	2224	Barasim Sak
A4	2206	Small Tabla Sak
A#4	2225	Barasim Tak
B4	2207	Small Tabla Tak
C5	2208	Big Tabla Dom
C#5	2226	Segal Dom
D5	2209	Big Tabla Tak
D#5	2227	Segal Tak
E5	2210	Big Tabla Sak
F5	2211	Tabla Dom
F#5	2212	Tabla Tak1
G5	2218	Tabla Tremolo
G#5	2213	Tabla Tak2
A5	2214	Tabla Tik1
A#5	2217	Tabla Sak1
B5	2216	Tabla Tik3
C6	2215	Tabla Tik2

PDR 60 Belly Dance Kit

Note	Wave Number	Wave Name
C0	2215	Tabla Tik2
C#0	2178	Wa Taiko
D0	2131	Djembe1 Edge
D#0	2132	Djembe1 Mute
E0	2133	Djembe1 Open
F0	2134	Djembe1 Combi
F#0	2141	Tabla Bya
G0	2142	Tabla Nah
G#0	2143	Tabla Mute
A0	2144	Tabla Combi
A#0	2204	Small Tabla Dom
B0	2204	Small Tabla Dom
C1	2686	Bd Hard Long
C#1	2644	Bd T9-1
D1	3287	Sd T9-2
D#1	2425	Electric Clap1
E1	2768	Sd Strong L1-4
F1	3861	Tom Dist Lo
F#1	3610	HH Closed T9
G1	3860	Tom Dist Hi
G#1	3612	HH Closed T8-1
A1	3857	Tom Syn1
A#1	3611	HH Open T9
B1	3858	Tom Syn2
C2	3318	Sd Hip1
C#2	3872	Crash4
D2	3314	Sd D&B4
D#2	3621	HH Closed Break
E2	3977	Reverse Cymbal
F2	2037	Timbale1 Lo 1-2
F#2	1970	Conga1 Hi Open 2
G2	2033	Timbale1 Hi 1-3
G#2	1972	Conga1 Hi Slap Open
A2	1927	Tambourine1 Sw
A#2	2001	Tumba Open
B2	2109	Cowbell1
C3	2106	Claves1
C#3	2007	Bongo1 Hi 1Fingr 1-2
D3	1939	Wood Block
D#3	2020	Bongo1 Lo 3Fingr 1-2
E3	1939	Wood Block
F3	2145	Dohol Low
F#3	2059	CabasaA 1-2
G3	2146	Dohol High
G#3	1917	ShakerA 1
A3	1935	Castanet1
A#3	2056	Maracas Sw
B3	1935	Castanet1
C4	2230	Twaisat3
C#4	2228	Twaisat1
D4	2229	Twaisat2
D#4	2231	Twaisat4
E4	2231	Twaisat4
F4	2204	Small Tabla Dom
F#4	2223	Barasim Dom
G4	2205	Small Tabla Snap
G#4	2224	Barasim Sak
A4	2206	Small Tabla Sak
A#4	2225	Barasim Tak
B4	2207	Small Tabla Tak
C5	2208	Big Tabla Dom
C#5	2226	Segal Dom
D5	2209	Big Tabla Tak
D#5	2227	Segal Tak
E5	2210	Big Tabla Sak
F5	2211	Tabla Dom
F#5	2212	Tabla Tak1
G5	2218	Tabla Tremolo
G#5	2213	Tabla Tak2
A5	2214	Tabla Tik1
A#5	2217	Tabla Sak1
B5	2216	Tabla Tik3
C6	2215	Tabla Tik2

PDR 61 Dance Snares

Note	Wave Number	Wave Name
C0	3332	Sd FX1
C#0	3333	Sd FX2
D0	3334	Sd FX3
D#0	3335	Sd FX4
E0	3337	Sd Dist
F0	3338	Sd Cut
F#0	3339	Sd Garg H
G0	3340	Sd Garg L
G#0	3341	Sd FM
A0	3343	Sd Syn
A#0	3347	Sd Hammer
B0	3348	Sd Lo-Fi
C1	3286	Sd T9-1
C#1	3287	Sd T9-2
D1	3288	Sd T9-3
D#1	3289	Sd T9-4
E1	3290	Sd T9-5
F1	3291	Sd T9Gate
F#1	3293	Sd T8-1
G1	3294	Sd T8-2
G#1	3295	Sd T8-3
A1	3296	Sd T8-4
A#1	3297	Sd T8-5
B1	3301	Sd AnSm
C2	3303	Sd AnCR
C#2	3305	Sd Human1
D2	3307	Sd Jungle1
D#2	3308	Sd Jungle2
E2	3309	Sd Jungle3
F2	3310	Sd JungleFX
F#2	3311	Sd D&B1
G2	3312	Sd D&B2
G#2	3313	Sd D&B3
A2	3314	Sd D&B4
A#2	3315	Sd R&B1
B2	3316	Sd R&B1 Rim
C3	3317	Sd R&B2
C#3	3318	Sd Hip1
D3	3319	Sd Hip2
D#3	3320	Sd Hip3
E3	3321	Sd Hip Gate
F3	3322	Sd Hip Rim1
F#3	3323	Sd Hip Rim2
G3	3324	Sd Hip Rim3
G#3	3325	Sd Hip Rim4
A3	3326	Sd Hip Rim5
A#3	3328	Sd Break2
B3	3330	Sd Break Heavy
C4	3274	Sd Elec1
C#4	3275	Sd Elec2
D4	3276	Sd Elec3
D#4	3277	Sd Elec4
E4	3278	Sd Elec5
F4	3279	Sd Elec6
F#4	3280	Sd Elec7
G4	3281	Sd Elec8
G#4	3282	Sd Elec9
A4	3283	Sd Elec10
A#4	3284	Sd Elec11
B4	3285	Sd Elec12
C5	3274	Sd Elec1
C#5	3294	Sd T8-2
D5	3276	Sd Elec3
D#5	3277	Sd Elec4
E5	3278	Sd Elec5
F5	3279	Sd Elec6
F#5	3280	Sd Elec7
G5	3274	Sd Elec1
G#5	3281	Sd Elec8
A5	3283	Sd Elec10
A#5	3284	Sd Elec11
B5	3285	Sd Elec12
C6	3288	Sd T9-3

PDR 62 Special SFXs

Note	Wave Number	Wave Name
C0	1519	Mini Blip2
C#0	1518	Mini Blip1
D0	1520	Mini Blip3
D#0	1521	Mini Blip4
E0	1522	Mini Blip5
F0	1523	Mini Blip6
F#0	1705	Bell FX1
G0	1706	Bell FX2
G#0	1714	Electric Perc4
A0	1716	Electric Perc6
A#0	1725	Electric Perc15
B0	1715	Electric Perc5
C1	1712	Electric Perc2
C#1	1713	Electric Perc3
D1	1717	Electric Perc7
D#1	1718	Electric Perc8
E1	1719	Electric Perc9
F1	1720	Electric Perc10
F#1	1724	Electric Perc14
G1	1723	Electric Perc13
G#1	1619	Neo Seq Em-3
A1	1448	Spectrum1
A#1	1450	Spectrum3
B1	1449	Spectrum2
C2	1625	Whisper Seq Bb
C#2	1694	Digi Voice Mod
D2	1560	Moving Chime St
D#2	1557	Engine Room St
E2	1661	Raspberry
F2	1662	DigiHeli
F#2	1614	Hop FX1
G2	1529	Willow St
G#2	1532	Anemone St
A2	1535	Magnitude St
A#2	1659	Radio Noise
B2	1613	Quiek
C3	1600	Stab Giant
C#3	1596	HH Hit
D3	1601	Stab Hard
D#3	1602	Stab Organ2
E3	1603	Stab Aah
F3	1604	Hit Uhh
F#3	1605	Hit Orchestra2
G3	1597	Hit Orchestra1
G#3	1598	Hit Brass
A3	1588	Orchestra Hit1 St
A#3	1591	Orchestra Hit2 St
B3	1006	Brass Sect Fall
C4	567	Play FX Mix
C#4	567	Play FX Mix
D4	1883	ElectricGtr FX23
D#4	1887	Acoustic Bass FX04
E4	1888	Acoustic Bass FX05
F4	1884	Acoustic Bass FX01
F#4	1748	Scratch H
G4	1749	Scratch L
G#4	1750	Scratch Down
A4	1751	Scratch Hi F
A#4	1761	Scratch Stop
B4	1730	Tape Rewind
C5	1703	Ripper
C#5	1708	Noise Burst
D5	1709	Zap1
D#5	1710	Zap2
E5	1726	Hi Q1
F5	1727	Hi Q2
F#5	1729	Bomb
G5	1731	FxGun1
G#5	1563	Motion Beam
A5	1526	Birch St
A#5	1387	Tri Wave
B5	1501	FM Bass2
C6	1394	FM Metal2

PDR 63 Synthetic Kit

Note	Wave Number	Wave Name
C0	2693	Bd Elec2
C#0	1761	Scratch Stop
D0	3218	Sd Brush Swir L
D#0	3210	Sd Brush Med R
E0	3217	Sd Brush Swir St
F0	3204	Sd Roll Mono
F#0	1505	FM Bass6
G0	1740	Seashore
G#0	1714	Electric Perc4
A0	2698	Bd ElecComp3
A#0	2775	Sd Strong R2
B0	2693	Bd Elec2
C1	2691	Bd Slimy
C#1	2041	Timbale1 Paila H
D1	2951	Sd Piccolo
D#1	2424	Clap AnSm
E1	3283	Sd Elec10
F1	1480	Mg Bass2
F#1	1727	Hi Q2
G1	1480	Mg Bass2
G#1	1717	Electric Perc7
A1	3856	Tom T8
A#1	3615	HH Open T8-2
B1	3856	Tom T8
C2	3856	Tom T8
C#2	3871	Crash3
D2	3856	Tom T8
D#2	3952	Ride Cup Mono
E2	3952	Ride Cup Mono
F2	3952	Ride Cup Mono
F#2	1757	Scratch Sd F
G2	3938	Ride Cup1 RL
G#2	1717	Electric Perc7
A2	3871	Crash3
A#2	1546	Hi-Lo
B2	3958	China2
C3	1390	Ring Mod
C#3	1718	Electric Perc8
D3	1390	Ring Mod
D#3	1717	Electric Perc7
E3	1721	Electric Perc11
F3	2052	Paila H
F#3	2052	Paila H
G3	1614	Hop FX1
G#3	1615	Hop FX2
A3	1748	Scratch H
A#3	1751	Scratch Hi F
B3	1710	Zap2
C4	1660	LFO Seq
C#4	1660	LFO Seq
D4	1458	Mini Bass3a
D#4	1613	Quiek
E4	1556	Digi Breath
F4	1662	DigiHeli
F#4	1717	Electric Perc7
G4	1395	FM Organ1
G#4	2150	Tibetan Bowl
A4	2150	Tibetan Bowl
A#4	2226	Segal Dom
B4	1559	Engine Room R
C5	1718	Electric Perc8
C#5	484	Steel Slide St
D5	1519	Mini Blip2
D#5	1449	Spectrum2
E5	1522	Mini Blip5
F5	1524	Noise
F#5	2664	Bd D&B1
G5	1449	Spectrum2
G#5	1538	SabreTone
A5	1724	Electric Perc14
A#5	1718	Electric Perc8
B5	1662	DigiHeli
C6	1957	Wind Chime

PDR 64 SFX Kit

Note	Wave Number	Wave Name
C0	1319	Fat Saw Mn
C#0	1765	Scratch Attack
D0	1449	Spectrum2
D#0	1452	3o3 Saw2
E0	1735	TurnTable
F0	3204	Sd Roll Mono
F#0	1505	FM Bass6
G0	1730	Tape Rewind
G#0	1715	Electric Perc5
A0	2697	Bd ElecComp2
A#0	2798	Sd Normal St1-4
B0	2691	Bd Slimy
C1	2693	Bd Elec2
C#1	1458	Mini Bass3a
D1	2886	Sd BluesHeart St1-3
D#1	1453	3o3 Square
E1	2867	Sd SonA 3L
F1	3860	Tom Dist Hi
F#1	1662	DigiHeli
G1	3860	Tom Dist Hi
G#1	1712	Electric Perc2
A1	3860	Tom Dist Hi
A#1	3615	HH Open T8-2
B1	3860	Tom Dist Hi
C2	3860	Tom Dist Hi
C#2	3871	Crash3
D2	3860	Tom Dist Hi
D#2	3937	Ride Cup1 R
E2	3914	Ride2 RL
F2	3953	Ride Cup Mono2
F#2	1751	Scratch Hi F
G2	3964	Splash1 L
G#2	1454	Mini Bass1
A2	3863	Crash1 St
A#2	1557	Engine Room St
B2	3938	Ride Cup1 RL
C3	1365	Sync LFO
C#3	1366	P5 SawDown 0 dg
D3	1325	OB Strings
D#3	2799	Sd Normal St1-3
E3	1721	Electric Perc11
F3	1333	PWM Slow
F#3	1660	LFO Seq
G3	1542	BigSyn
G#3	1542	BigSyn
A3	1605	Hit Orchestra2
A#3	2204	Small Tabla Dom
B3	1406	Digi 03
C4	1406	Digi 03
C#4	1404	Digi 01
D4	1404	Digi 01
D#4	1554	Sonar1
E4	1601	Stab Hard
F4	1557	Engine Room St
F#4	1666	Chatter
G4	1672	Hoo
G#4	2148	Mondira
A4	2148	Mondira
A#4	394	Rotor
B4	1661	Raspberry
C5	1662	DigiHeli
C#5	1453	3o3 Square
D5	1615	Hop FX2
D#5	1443	DigiBell3
E5	1728	Vox Hit Rev
F5	1726	Hi Q1
F#5	1730	Tape Rewind
G5	1732	FxGun2
G#5	1731	FxGun1
A5	1733	Thunder
A#5	1736	Police
B5	1729	Bomb
C6	1729	Bomb

PDR 65 Maple Custom Kit

Note	Wave Number	Wave Name
C0	2110	Cowbell2
C#0	3205	Sd Brush Soft St
D0	3217	Sd Brush Swir St
D#0	3208	Sd Brush Med St
E0	3220	Sd Brush SwirAtt St
F0	3134	Sd Metal SnRoll St
F#0	1935	Castanet1
G0	3074	Sd Beech 1-4 St
G#0	1934	Stick2
A0	2582	Bd Oak Open 1-2 St
A#0	3092	Sd Beech OpRm 1-2 St
B0	2564	Bd Maple Close 1-2St
C1	2573	Bd Maple Open 1-2 St
C#1	3131	Sd Metal ClRm St
D1	3104	Sd Metal 1-4 St
D#1	1945	Hand Clap1 St
E1	3122	Sd Metal OpRm 1-2 St
F1	3739	Tom Maple Flr 1-2 St
F#1	3519	HH Dark Closed 1-4St
G1	3739	Tom Maple Flr 1-2 St
G#1	3539	HH Dark Pedal 1-2 St
A1	3727	Tom Maple Mid 1-2 St
A#1	3551	HH Dark Open 1-2 St
B1	3715	Tom Maple Hi 1-2 St
C2	3715	Tom Maple Hi 1-2 St
C#2	3873	Crash Brite St
D2	3715	Tom Maple Hi 1-2 St
D#2	3915	Ride Brite St
E2	3959	China3 St
F2	3919	Ride Brite Cup St
F#2	1930	Tambourine2 Sw
G2	3967	Splash2 St
G#2	2111	Cowbell3 Sw
A2	3877	Crash Dark St
A#2	1941	Vibraslap2
B2	3923	Ride Warm St
C3	2028	Bongo2 Hi Open 2
C#3	2032	Bongo2 Lo Open 2
D3	1988	Conga2 Hi Slap 2
D#3	1991	Conga2 Hi Open 2
E3	1994	Conga2 Lo Open 1
F3	2033	Timbale1 Hi 1-3
F#3	2037	Timbale1 Lo 1-2
G3	2080	Agogo Hi
G#3	2081	Agogo Lo
A3	2062	CabasaB 1-4
A#3	2057	Maracas Slur
B3	2108	Whistle
C4	2108	Whistle
C#4	2086	MetalGuro Short 1-2
D4	2089	MetalGuro Long
D#4	2107	Claves2
E4	1958	Resin Block Small
F4	1959	Resin Block Large
F#4	2006	Cuica Hi
G4	2005	Cuica Lo
G#4	1944	Triangle Mute
A4	1943	Triangle Open
A#4	1920	ShakerB Sw
B4	1955	Sleigh Bell2
C5	1956	Ghunghuru
C#5	2093	Surdo2 Mute
D5	2092	Surdo2 Open
D#5	1985	Conga2 Hi Tip
E5	1984	Conga2 Hi Heel
F5	1986	Conga2 Hi Slap 1-2
F#5	1992	Conga2 Hi Mute
G5	1989	Conga2 Hi Open 1-2
G#5	1996	Conga2 Lo Slide
A5	1993	Conga2 Lo Open 1-2
A#5	2137	Djembe2 Mute
B5	2135	Djembe2 Lo
C6	2136	Djembe2 Slap

PDR 66 Oak Custom Kit

Note	Wave Number	Wave Name
C0	2110	Cowbell2
C#0	3205	Sd Brush Soft St
D0	3217	Sd Brush Swir St
D#0	3208	Sd Brush Med St
E0	3220	Sd Brush SwirAtt St
F0	3134	Sd Metal SnRoll St
F#0	1935	Castanet1
G0	3104	Sd Metal 1-4 St
G#0	1934	Stick2
A0	2582	Bd Oak Open 1-2 St
A#0	3122	Sd Metal OpRm 1-2 St
B0	2591	Bd Oak Close 1-2 St
C1	2582	Bd Oak Open 1-2 St
C#1	3071	Sd Oak ClRm St
D1	3044	Sd Oak 1-4 St
D#1	1945	Hand Clap1 St
E1	3062	Sd Oak OpRm 1-2 St
F1	3775	Tom Oak Floor 1-2 St
F#1	3519	HH Dark Closed 1-4St
G1	3775	Tom Oak Floor 1-2 St
G#1	3539	HH Dark Pedal 1-2 St
A1	3763	Tom Oak Mid 1-2 St
A#1	3551	HH Dark Open 1-2 St
B1	3763	Tom Oak Mid 1-2 St
C2	3751	Tom Oak Hi 1-2 St
C#2	3873	Crash Brite St
D2	3751	Tom Oak Hi 1-2 St
D#2	3915	Ride Brite St
E2	3959	China3 St
F2	3919	Ride Brite Cup St
F#2	1930	Tambourine2 Sw
G2	3967	Splash2 St
G#2	2111	Cowbell3 Sw
A2	3877	Crash Dark St
A#2	1941	Vibraslap2
B2	3923	Ride Warm St
C3	2028	Bongo2 Hi Open 2
C#3	2032	Bongo2 Lo Open 2
D3	1988	Conga2 Hi Slap 2
D#3	1991	Conga2 Hi Open 2
E3	1994	Conga2 Lo Open 1
F3	2045	Timbale2 Hi 2
F#3	2049	Timbale2 Lo 2
G3	2080	Agogo Hi
G#3	2081	Agogo Lo
A3	2062	CabasaB 1-4
A#3	2057	Maracas Slur
B3	2108	Whistle
C4	2108	Whistle
C#4	2086	MetalGuro Short 1-2
D4	2089	MetalGuro Long
D#4	2107	Claves2
E4	1958	Resin Block Small
F4	1959	Resin Block Large
F#4	2006	Cuica Hi
G4	2005	Cuica Lo
G#4	1944	Triangle Mute
A4	1943	Triangle Open
A#4	1920	ShakerB Sw
B4	1955	Sleigh Bell2
C5	1957	Wind Chime
C#5	2093	Surdo2 Mute
D5	2092	Surdo2 Open
D#5	1985	Conga2 Hi Tip
E5	1984	Conga2 Hi Heel
F5	1986	Conga2 Hi Slap 1-2
F#5	1992	Conga2 Hi Mute
G5	1989	Conga2 Hi Open 1-2
G#5	1996	Conga2 Lo Slide
A5	1993	Conga2 Lo Open 1-2
A#5	2137	Djembe2 Mute
B5	2135	Djembe2 Lo
C6	2136	Djembe2 Slap

PDR 67 Nu Jazzy Kit

Note	Wave Number	Wave Name
C0	2110	Cowbell2
C#0	3205	Sd Brush Soft St
D0	3217	Sd Brush Swir St
D#0	3208	Sd Brush Med St
E0	3220	Sd Brush SwirAtt St
F0	3134	Sd Metal SnRoll St
F#0	1951	Finger Snap
G0	3104	Sd Metal 1-4 St
G#0	1934	Stick2
A0	2582	Bd Oak Open 1-2 St
A#0	3122	Sd Metal OpRm 1-2 St
B0	2600	Bd NJz Closed 1-2 St
C1	2609	Bd NJz Open 1-2 St
C#1	3164	Sd NJz ClRm St
D1	3137	Sd NJz 1-4 St
D#1	1948	Hand Clap2 Sw
E1	3155	Sd NJz OpRm 1-2 St
F1	3811	Tom NJz Floor 1-2 St
F#1	3563	HH NJz Closed 1-4 St
G1	3811	Tom NJz Floor 1-2 St
G#1	3583	HH NJz Pedal 1-2 St
A1	3799	Tom NJz Low 1-2 St
A#1	3595	HH NJz Open 1-2 St
B1	3799	Tom NJz Low 1-2 St
C2	3787	Tom NJz Mid 1-2 St
C#2	3885	Crash NJzB St
D2	3787	Tom NJz Mid 1-2 St
D#2	3927	Ride NJz St
E2	3959	China3 St
F2	3931	Ride NJz Cup St
F#2	1930	Tambourine2 Sw
G2	3967	Splash2 St
G#2	2111	Cowbell3 Sw
A2	3881	Crash NJzA St
A#2	1941	Vibraslap2
B2	3923	Ride Warm St
C3	2028	Bongo2 Hi Open 2
C#3	2032	Bongo2 Lo Open 2
D3	1988	Conga2 Hi Slap 2
D#3	1991	Conga2 Hi Open 2
E3	1994	Conga2 Lo Open 1
F3	2033	Timbale1 Hi 1-3
F#3	2037	Timbale1 Lo 1-2
G3	2080	Agogo Hi
G#3	2081	Agogo Lo
A3	2062	CabasaB 1-4
A#3	2057	Maracas Slur
B3	2108	Whistle
C4	2108	Whistle
C#4	2086	MetalGuro Short 1-2
D4	2089	MetalGuro Long
D#4	2107	Claves2
E4	1958	Resin Block Small
F4	1959	Resin Block Large
F#4	2006	Cuica Hi
G4	2005	Cuica Lo
G#4	1944	Triangle Mute
A4	1943	Triangle Open
A#4	1920	ShakerB Sw
B4	1954	Sleigh Bell1
C5	1957	Wind Chime
C#5	2093	Surdo2 Mute
D5	2092	Surdo2 Open
D#5	1985	Conga2 Hi Tip
E5	1984	Conga2 Hi Heel
F5	1986	Conga2 Hi Slap 1-2
F#5	1992	Conga2 Hi Mute
G5	1989	Conga2 Hi Open 1-2
G#5	1996	Conga2 Lo Slide
A5	1993	Conga2 Lo Open 1-2
A#5	2137	Djembe2 Mute
B5	2135	Djembe2 Lo
C6	2136	Djembe2 Slap

PDR 68 Illest Hip Hop Kit

Note	Wave Number	Wave Name
C0	2706	Bd HipHop2
C#0	3363	Sd HipHop16
D0	3356	Sd HipHop9
D#0	2450	HipHop Clap9
E0	2715	Bd HipHop11
F0	2451	HipHop Clap10
F#0	3362	Sd HipHop15
G0	3353	Sd HipHop5
G#0	3361	Sd HipHop14
A0	2712	Bd HipHop8
A#0	3371	Sd HipHop Rim6
B0	2717	Bd HipHop13
C1	2716	Bd HipHop12
C#1	3369	Sd HipHop Rim4
D1	3360	Sd HipHop13
D#1	2454	HipHop Clap13
E1	3351	Sd HipHop2
F1	3842	Tom Dry Lo
F#1	3505	HH Power ClEgde 3R
G1	3842	Tom Dry Lo
G#1	3509	HH Power ClEgde 4R
A1	3841	Tom Dry Hi
A#1	3517	HH Power Open EdgeR
B1	3841	Tom Dry Hi
C2	3841	Tom Dry Hi
C#2	3872	Crash4
D2	3841	Tom Dry Hi
D#2	3912	Ride2 L
E2	3868	Crash2 L
F2	3951	Ride Mono
F#2	1929	Tambourine1 Hit
G2	3902	Hand Cymbal Open L
G#2	2117	Mambo Bell Body
A2	3956	China1 R
A#2	1952	Handbell L
B2	3953	Ride Cup Mono2
C3	1972	Conga1 Hi Slap Open
C#3	1980	Conga1 Lo Open 1
D3	1977	Conga1 Lo Tip
D#3	1983	Conga1 Lo Slap Open
E3	1981	Conga1 Lo Open 2
F3	2708	Bd HipHop4
F#3	2444	HipHop Clap3
G3	3627	HH Closed Tek
G#3	3627	HH Closed Tek
A3	1918	ShakerA 2
A#3	1917	ShakerA 1
B3	2714	Bd HipHop10
C4	2680	Bd +HH
C#4	3359	Sd HipHop12
D4	3364	Sd HipHop17
D#4	2453	HipHop Clap12
E4	2714	Bd HipHop10
F4	3355	Sd HipHop7
F#4	2455	HipHop Clap14
G4	2452	HipHop Clap11
G#4	1944	Triangle Mute
A4	1943	Triangle Open
A#4	1927	Tambourine1 Sw
B4	1918	ShakerA 2
C5	2712	Bd HipHop8
C#5	2423	Clap T9
D5	3293	Sd T8-1
D#5	3365	Sd HipHop18
E5	3296	Sd T8-4
F5	3856	Tom T8
F#5	3614	HH Closed T8-2
G5	3856	Tom T8
G#5	3614	HH Closed T8-2
A5	3856	Tom T8
A#5	3615	HH Open T8-2
B5	3856	Tom T8
C6	3972	Crash T8

PDR 69 PercussionMaster Kit

Note	Wave Number	Wave Name
C0	2110	Cowbell2
C#0	2135	Djembe2 Lo
D0	2136	Djembe2 Slap
D#0	2137	Djembe2 Mute
E0	2073	Pandeiro Open
F0	2076	Pandeiro Heel
F#0	2074	Pandeiro Thump
G0	2075	Pandeiro Tip
G#0	1936	Castanet2 Sw
A0	2140	Djembe3 Mute
A#0	2139	Djembe3 Slap
B0	2138	Djembe3 Lo
C1	2100	Cajon2 Lo
C#1	2099	Cajon2 Foot
D1	2101	Cajon2 Slap
D#1	1948	Hand Clap2 Sw
E1	2102	Cajon2 Mute
F1	3849	Rotary Tom Lo 1-2
F#1	2103	Cajon2 Tip
G1	2166	Sangban Sw
G#1	2104	Cajon2 Ghost1
A1	3846	Rotary Tom Mid 1-2
A#1	2105	Cajon2 Ghost2
B1	2166	Sangban Sw
C2	3843	Rotary Tom Hi 1-2
C#2	2169	Dundun Bell Sw
D2	2163	Kenkeni Sw
D#2	3915	Ride Brite St
E2	3959	China3 St
F2	3919	Ride Brite Cup St
F#2	1930	Tambourine2 Sw
G2	3967	Splash2 St
G#2	2111	Cowbell3 Sw
A2	2052	Paila H
A#2	1941	Vibraslap2
B2	2051	Paila L
C3	1984	Conga2 Hi Heel
C#3	1985	Conga2 Hi Tip
D3	1986	Conga2 Hi Slap 1-2
D#3	1992	Conga2 Hi Mute
E3	1989	Conga2 Hi Open 1-2
F3	2043	Timbale2 Hi Sw
F#3	2047	Timbale2 Lo Sw
G3	2118	ChaCha Bell Sw
G#3	2114	Mambo Bell Sw
A3	2062	CabasaB 1-4
A#3	2067	Caxixi 1-2
B3	2025	Bongo2 Hi Mute
C4	2026	Bongo2 Hi Open 1-2
C#4	2029	Bongo2 Lo Mute
D4	2030	Bongo2 Lo Open 1-2
D#4	2107	Claves2
E4	1958	Resin Block Small
F4	1959	Resin Block Large
F#4	1996	Conga2 Lo Slide
G4	1993	Conga2 Lo Open 1-2
G#4	1944	Triangle Mute
A4	1943	Triangle Open
A#4	1920	ShakerB Sw
B4	1957	Wind Chime
C5	2158	TalkingDrum Bend 1-4
C#5	2157	TalkingDrum Mute
D5	2155	TalkingDrum Open
D#5	2156	TalkingDrum Slap
E5	2124	Repique Open 1-2
F5	2123	Repique Mute
F#5	2151	Shekere Shake Sw
G5	2154	Shekere Slap
G#5	2121	Samba Tambourim Slap
A5	2120	Samba Tambourim Open
A#5	2122	Samba Tambourim Mute
B5	2093	Surdo2 Mute
C6	2092	Surdo2 Open

PDR 70 Nu Orchestra Kit

Note	Wave Number	Wave Name
C0	2107	Claves2
C#0	3209	Sd Brush Med L
D0	3219	Sd Brush Swir R
D#0	3209	Sd Brush Med L
E0	3222	Sd Brush SwirAtt R
F0	3256	Sd Orch Roll St
F#0	1936	Castanet2 Sw
G0	3223	Sd OrchA 1-2 St
G#0	1933	Stick1
A0	2639	Bd GranCasaB Mfl St
A#0	2636	Bd GranCasaB Hoop St
B0	2624	Bd GranCasaB 1-3 St
C1	2624	Bd GranCasaB 1-3 St
C#1	3101	Sd Beech Clrm St
D1	3241	Sd OrchC 1-4 St
D#1	1945	Hand Clap1 St
E1	3241	Sd OrchC 1-4 St
F1	3703	Tom Power05 1-2St
F#1	1961	OrchTamb Shake 1-2
G1	3703	Tom Power05 1-2St
G#1	1964	OrchTamb Hit Close
A1	3699	Tom Power04 2St
A#1	1965	OrchTamb Hit Open
B1	3699	Tom Power04 2St
C2	3679	Tom Power03 1-2St
C#2	3901	Hand Cymbal Open St
D2	3679	Tom Power03 1-2St
D#2	3930	Ride NJz RL
E2	3959	China3 St
F2	3934	Ride NJz Cup RL
F#2	1927	Tambourine1 Sw
G2	2148	Mondira
G#2	2111	Cowbell3 Sw
A2	3904	Hand Cymbal Mute St
A#2	1941	Vibraslap2
B2	3942	Ride Brush1 RL
C3	2618	Bd GranCasaA Open St
C#3	2621	Bd GranCasaA Mute St
D3	3262	Sd Field 1 St
D#3	1955	Sleigh Bell2
E3	3262	Sd Field 1 St
F3	1939	Wood Block
F#3	1939	Wood Block
G3	2457	HipHop Flex2
G#3	1944	Triangle Mute
A3	1943	Triangle Open
A#3	1920	ShakerB Sw
B3	2062	CabasaB 1-4
C4	284	Timpani2 Hard St
C#4	284	Timpani2 Hard St
D4	284	Timpani2 Hard St
D#4	284	Timpani2 Hard St
E4	284	Timpani2 Hard St
F4	284	Timpani2 Hard St
F#4	284	Timpani2 Hard St
G4	284	Timpani2 Hard St
G#4	284	Timpani2 Hard St
A4	284	Timpani2 Hard St
A#4	284	Timpani2 Hard St
B4	284	Timpani2 Hard St
C5	284	Timpani2 Hard St
C#5	284	Timpani2 Hard St
D5	284	Timpani2 Hard St
D#5	284	Timpani2 Hard St
E5	284	Timpani2 Hard St
F5	284	Timpani2 Hard St
F#5	284	Timpani2 Hard St
G5	284	Timpani2 Hard St
G#5	284	Timpani2 Hard St
A5	284	Timpani2 Hard St
A#5	284	Timpani2 Hard St
B5	284	Timpani2 Hard St
C6	284	Timpani2 Hard St

PDR 71 Japan Kit

Note	Wave Number	Wave Name
C0	2441	Analog Click
C#0	2178	Wa Taiko
D0	2178	Wa Taiko
D#0	2178	Wa Taiko
E0	2178	Wa Taiko
F0	2178	Wa Taiko
F#0	2178	Wa Taiko
G0	2178	Wa Taiko
G#0	1955	Sleigh Bell2
A0	2183	Oo Taiko2 Zu
A#0	2184	Oo Taiko2 Ka
B0	2182	Oo Taiko2 Don Hard
C1	2182	Oo Taiko2 Don Hard
C#1	2184	Oo Taiko2 Ka
D1	2192	Shime Taiko1 Tsu
D#1	2193	Shime Taiko1 Ku
E1	2191	Shime Taiko1 Ten
F1	2188	Yagura Taiko2 Don
F#1	2175	Chanchiki Ki
G1	2189	Yagura Taiko2 Zu
G#1	2175	Chanchiki Ki
A1	2190	Yagura Taiko2 Ka
A#1	2174	Chanchiki Chan
B1	2179	Oo Taiko1 Don
C2	2179	Oo Taiko1 Don
C#2	2180	Oo Taiko1 Ka
D2	2195	Shime Taiko2 Tsu
D#2	2196	Shime Taiko2 Ku
E2	2194	Shime Taiko2 Ten
F2	2185	Yagura Taiko1 Don
F#2	2177	Atarigane Chi
G2	2186	Yagura Taiko1 Zu
G#2	2177	Atarigane Chi
A2	2187	Yagura Taiko1 Ka
A#2	2176	Atarigane Con
B2	2203	Oo Kawa Ton
C3	2201	Oo Kawa Chon
C#3	2202	Oo Kawa Tsu
D3	2197	Tsuzumi Pon
D#3	2199	Tsuzumi Chi
E3	2198	Tsuzumi Pu
F3	2200	Tsuzumi Ta
F#3	2172	Ainote 1
G3	2197	Tsuzumi Pon
G#3	2199	Tsuzumi Chi
A3	2198	Tsuzumi Pu
A#3	2173	Ainote 2
B3	2200	Tsuzumi Ta
C4	2191	Shime Taiko1 Ten
C#4	2191	Shime Taiko1 Ten
D4	2191	Shime Taiko1 Ten
D#4	2191	Shime Taiko1 Ten
E4	2191	Shime Taiko1 Ten
F4	2191	Shime Taiko1 Ten
F#4	2191	Shime Taiko1 Ten
G4	2191	Shime Taiko1 Ten
G#4	2191	Shime Taiko1 Ten
A4	2191	Shime Taiko1 Ten
A#4	2191	Shime Taiko1 Ten
B4	2191	Shime Taiko1 Ten
C5	1270	Pan Flute
C#5	1270	Pan Flute
D5	1270	Pan Flute
D#5	1270	Pan Flute
E5	1270	Pan Flute
F5	1270	Pan Flute
F#5	1270	Pan Flute
G5	1270	Pan Flute
G#5	1270	Pan Flute
A5	1270	Pan Flute
A#5	1270	Pan Flute
B5	1270	Pan Flute
C6	1270	Pan Flute

PDR 72 Turkish Kit

Note	Wave Number	Wave Name
C0	2106	Claves1
C#0	2235	AsmaDavul L Side 1-2
D0	2239	AsmaDavul R Side 1-2
D#0	2232	AsmaDavulSideBdy 1-2
E0	2238	AsmaDavul Both Sides
F0	2253	KoltukDavulOpenFlam
F#0	2245	KoltukDavulTekeOp1-3
G0	2249	KoltukDavulTekOp 1-3
G#0	2242	Koltuk Davul Dum 1-2
A0	2265	Bendir Teke OpenFlam
A#0	2272	Bendir Teke Dead 1-2
B0	2269	Bendir Tek Dead 1-2
C1	2261	Bendir Teke 1-3
C#1	2257	Bendir Tek 1-3
D1	2266	Bendir Slap 1-2
D#1	2254	Bendir Dum 1-2
E1	2276	Sagat R Close 1-2
F1	2275	Sagat R Open
F#1	2280	Sagat L Close 1-2
G1	2279	Sagat L Open
G#1	2296	Riq Teke Flam
A1	2290	Riq Tek Mute 1-2
A#1	2293	Riq Teke Damped 1-2
B1	2297	RiqTekMuteMed 1-2
C2	2283	Riq Dum Mute
C#2	2307	Riq Cymbal 1-2
D2	2310	Riq Cymbal Mute 1-2
D#2	2320	Riq Tremolo
E2	2314	Riq ShakeA 1-2
F2	2317	Riq ShakeB 1-2
F#2	2306	Riq Tek Flam
G2	2313	Riq Full Open
G#2	2303	RiqTekeOpenShort 1-2
A2	2300	RiqTekOpenShort 1-2
A#2	2287	Riq Tek Open 1-2
B2	2284	Riq Dum Open 1-2
C3	2327	Hollo FingerDead 1-2
C#3	2324	Hollo Slap 1-2
D3	2321	Hollo Dum 1-2
D#3	2407	Kasik 1-2
E3	2411	Kasik Flam
F3	2348	Tombek Tek Dead Sw
F#3	2350	Tombek Tek Flam
G3	2354	Tombek Teke 1-3
G#3	2344	TombekTekeOthFng 1-3
A3	2340	TombekTekelndFng 1-3
A#3	2336	Tombek Tek 1-3
B3	2333	Tombek Slap 1-2
C4	2351	Tombek Slap Med 1-2
C#4	2330	Tombek Dum 1-2
D4	2394	Darbuka Roll Close
D#4	2392	Darbuka RollOpen
E4	2393	Darbuka TekeDampFlam
F4	2395	Darbuka TekDead 1-3
F#4	2399	Darbuka TekDampd 1-3
G4	2391	Darbuka TekeOpenFlam
G#4	2403	Darbuka TekeOpen 1-3
A4	2377	DarbTekeOthFngA 1-3
A#4	2369	DarbTekeInndFngA 1-3
B4	2361	Darbuka TekA 1-3
C5	2381	DarbTekeOthFngB 1-3
C#5	2373	DarbTekeInndFngB 1-3
D5	2365	Darbuka TekB 1-3
D#5	2388	Darbuka SlapMed 1-2
E5	2385	Darbuka Slap 1-2
F5	2358	Darbuka Dum 1-2
F#5	2420	Bonges Tek Roll
G5	2421	Bonges Flam
G#5	2419	Bonges Tek Flam
A5	2415	Bonges Tek 1-2
A#5	2418	Bonges Slap
B5	2422	Bonges Flam Hi
C6	2412	Bonges Dum 1-2

GM Drum Stereo GM Kit

Note	Wave Number	Wave Name
C0	2106	Claves1
C#0	3205	Sd Brush Soft St
D0	3217	Sd Brush Swir St
D#0	3208	Sd Brush Med St
E0	3220	Sd Brush SwirAtt St
F0	3201	Sd LiveRoll St
F#0	1935	Castanet1
G0	2804	Sd Normal 1St
G#0	1933	Stick1
A0	2496	Bd Funk St1-2
A#0	2838	Sd Basic St2-3
B0	2505	Bd High St
C1	2487	Bd Normal St1-2
C#1	3190	Sd Closed Rim St
D1	2798	Sd Normal St1-4
D#1	2423	Clap T9
E1	2837	Sd Basic St1-2
F1	3651	Tom Floor St
F#1	3372	HH Closed 1-4St
G1	3647	Tom Low St
G#1	3395	HH Pedal 3 St
A1	3647	Tom Low St
A#1	3410	HH Open 2St
B1	3643	Tom Mid St
C2	3643	Tom Mid St
C#2	3867	Crash2 St
D2	3639	Tom Hi St
D#2	3907	Ride1 St
E2	3954	China1 St
F2	3935	Ride Cup1 St
F#2	1927	Tambourine1 Sw
G2	3963	Splash1 St
G#2	2110	Cowbell2
A2	3870	Crash2 RL
A#2	1940	Vibraslap1
B2	3910	Ride1 RL
C3	2007	Bongo1 Hi 1Fingr 1-2
C#3	2020	Bongo1 Lo 3Fingr 1-2
D3	1966	Conga1 Hi Tip
D#3	1970	Conga1 Hi Open 2
E3	2001	Tumba Open
F3	2033	Timbale1 Hi 1-3
F#3	2037	Timbale1 Lo 1-2
G3	2080	Agogo Hi
G#3	2081	Agogo Lo
A3	2059	CabasaA 1-2
A#3	2057	Maracas Slur
B3	2108	Whistle
C4	2108	Whistle
C#4	2084	Guiro Short
D4	2083	Guiro Long
D#4	2106	Claves1
E4	1939	Wood Block
F4	1939	Wood Block
F#4	2006	Cuica Hi
G4	2005	Cuica Lo
G#4	1944	Triangle Mute
A4	1943	Triangle Open
A#4	1917	ShakerA 1
B4	1954	Sleigh Bell1
C5	1957	Wind Chime
C#5	2878	Sd Blues L1-3
D5	2901	Sd Tight St1-4
D#5	2894	Sd BluesHeart R1-3
E5	2921	Sd Hip St1-2
F5	2508	Bd Low St
F#5	3169	Sd LdwHMono
G5	2666	Bd R&B1
G#5	3172	Sd Heavy
A5	2531	Bd Room1
A#5	2956	Sd Ambience
B5	2517	Bd Funk Son St
C6	2532	Bd Room2

Waveform List

No.	Name	Main Category	Sub Category	No.	Name	Main Category	Sub Category	No.	Name	Main Category	Sub Category	No.	Name	Main Category	Sub Category
1	CF3 Stretch Sw St	Ap	Pno	80	S6 Stretch Sw St	Ap	Pno	159	EP2 Soft1	Kb	Rds	238	CP70+	Kb	Other
2	CF3 Stretch Sw Mn	Ap	Pno	81	S6 Stretch Sw Mn	Ap	Pno	160	EP2 Soft1+	Kb	Rds	239	CP70-	Kb	Other
3	CF3 Stretch Soft St	Ap	Pno	82	S6 Stretch Sw L	Ap	Pno	161	EP2 Soft1-	Kb	Rds	240	Celesta	Kb	Other
4	CF3 Stretch Soft Mn	Ap	Pno	83	S6 Stretch Sw R	Ap	Pno	162	EP2 Soft2	Kb	Rds	241	Vibraphone1	Cp	Malet
5	CF3 Stretch Soft St+	Ap	Pno	84	S6 Stretch Sw St Pan	Ap	Pno	163	EP2 Soft2+	Kb	Rds	242	Vibraphone2 Med	Cp	Malet
6	CF3 Stretch Soft Mn+	Ap	Pno	85	S6 Stretch Sw Sl2	Ap	Pno	164	EP2 Soft2-	Kb	Rds	243	Vibraphone2 Med+	Cp	Malet
7	CF3 Stretch Soft St-	Ap	Pno	86	S6 Stretch Sw St+	Ap	Pno	165	EP2 Hard1	Kb	Rds	244	Vibraphone2 Med-	Cp	Malet
8	CF3 Stretch Soft Mn-	Ap	Pno	87	S6 Stretch Sw Mn+	Ap	Pno	166	EP2 Hard1+	Kb	Rds	245	Vibraphone2 Hard	Cp	Malet
9	CF3 Stretch Med St	Ap	Pno	88	S6 Stretch Sw St-	Ap	Pno	167	EP2 Hard1-	Kb	Rds	246	Vibraphone2 Hard+	Cp	Malet
10	CF3 Stretch Med Mn	Ap	Pno	89	S6 Stretch Sw Mn-	Ap	Pno	168	EP2 Hard2	Kb	Rds	247	Vibraphone2 Hard-	Cp	Malet
11	CF3 Stretch Med St+	Ap	Pno	90	S6 Stretch KeyOff St	Ap	Pno	169	EP2 Hard2+	Kb	Rds	248	Marimba	Cp	Malet
12	CF3 Stretch Med Mn+	Ap	Pno	91	S6 Stretch KeyOff Mn	Ap	Pno	170	EP2 Hard2-	Kb	Rds	249	Glockenspiel	Cp	Malet
13	CF3 Stretch Med St-	Ap	Pno	92	S6 Stretch KeyOff L	Ap	Pno	171	EP3 Sw	Kb	Rds	250	Xylophone	Cp	Malet
14	CF3 Stretch Med Mn-	Ap	Pno	93	S6 Stretch KeyOff R	Ap	Pno	172	EP3 Soft1	Kb	Rds	251	Timpani1 Sw St	Cp	Malet
15	CF3 Stretch Hard St	Ap	Pno	94	S6 Stretch KeyOISI Pn	Ap	Pno	173	EP3 Soft1+	Kb	Rds	252	Timpani1 Soft St	Cp	Malet
16	CF3 Stretch Hard Mn	Ap	Pno	95	S6 Flat pp St	Ap	Pno	174	EP3 Soft1-	Kb	Rds	253	Timpani1 Hard St	Cp	Malet
17	CF3 Stretch Hard St+	Ap	Pno	96	S6 Flat pp Mn	Ap	Pno	175	EP3 Soft2	Kb	Rds	254	Timpani1 Sw L	Cp	Malet
18	CF3 Stretch Hard Mn+	Ap	Pno	97	S6 Flat pp L	Ap	Pno	176	EP3 Soft2+	Kb	Rds	255	Timpani1 Soft L	Cp	Malet
19	CF3 Stretch Hard St-	Ap	Pno	98	S6 Flat pp R	Ap	Pno	177	EP3 Soft2-	Kb	Rds	256	Timpani1 Hard L	Cp	Malet
20	CF3 Stretch Hard Mn-	Ap	Pno	99	S6 Flat pp St Pan	Ap	Pno	178	EP3 Hard1	Kb	Rds	257	Timpani1 Sw R	Cp	Malet
21	CF3 Key Off St	Ap	Pno	100	S6 Flat pp St+	Ap	Pno	179	EP3 Hard1+	Kb	Rds	258	Timpani1 Soft R	Cp	Malet
22	CF3 Key Off L	Ap	Pno	101	S6 Flat pp Mn+	Ap	Pno	180	EP3 Hard1-	Kb	Rds	259	Timpani1 Hard R	Cp	Malet
23	CF3 Key Off R	Ap	Pno	102	S6 Flat pp St-	Ap	Pno	181	EP3 Hard2	Kb	Rds	260	Timpani2 Soft St	Cp	Malet
24	CF3 Flat Sw St	Ap	Pno	103	S6 Flat pp Mn-	Ap	Pno	182	EP3 Hard2+	Kb	Rds	261	Timpani2 Soft L	Cp	Malet
25	CF3 Flat Sw Mn	Ap	Pno	104	S6 Flat mp St	Ap	Pno	183	EP3 Hard2-	Kb	Rds	262	Timpani2 Soft R	Cp	Malet
26	CF3 Flat Soft St	Ap	Pno	105	S6 Flat mp Mn	Ap	Pno	184	EP Key Off	Kb	Rds	263	Timpani2 Soft St+	Cp	Malet
27	CF3 Flat Soft Mn	Ap	Pno	106	S6 Flat mp L	Ap	Pno	185	Wurli EP Soft	Kb	Wur	264	Timpani2 Soft L+	Cp	Malet
28	CF3 Flat Soft St+	Ap	Pno	107	S6 Flat mp R	Ap	Pno	186	Wurli EP Soft+	Kb	Wur	265	Timpani2 Soft R+	Cp	Malet
29	CF3 Flat Soft Mn+	Ap	Pno	108	S6 Flat mp St Pan	Ap	Pno	187	Wurli EP Soft-	Kb	Wur	266	Timpani2 Soft St-	Cp	Malet
30	CF3 Flat Soft St-	Ap	Pno	109	S6 Flat mp St+	Ap	Pno	188	Wurli EP Med	Kb	Wur	267	Timpani2 Soft L-	Cp	Malet
31	CF3 Flat Soft Mn-	Ap	Pno	110	S6 Flat mp Mn+	Ap	Pno	189	Wurli EP Med+	Kb	Wur	268	Timpani2 Soft R-	Cp	Malet
32	CF3 Flat Med St	Ap	Pno	111	S6 Flat mp St-	Ap	Pno	190	Wurli EP Med-	Kb	Wur	269	Timpani2 Med St	Cp	Malet
33	CF3 Flat Med Mn	Ap	Pno	112	S6 Flat mp Mn-	Ap	Pno	191	Wurli EP Hard	Kb	Wur	270	Timpani2 Med L	Cp	Malet
34	CF3 Flat Med St+	Ap	Pno	113	S6 Flat mf St	Ap	Pno	192	Wurli EP Hard+	Kb	Wur	271	Timpani2 Med R	Cp	Malet
35	CF3 Flat Med Mn+	Ap	Pno	114	S6 Flat mf Mn	Ap	Pno	193	Wurli EP Hard-	Kb	Wur	272	Timpani2 Med St+	Cp	Malet
36	CF3 Flat Med St-	Ap	Pno	115	S6 Flat mf L	Ap	Pno	194	Wurli EP Key Off	Kb	Wur	273	Timpani2 Med L	Cp	Malet
37	CF3 Flat Med Mn-	Ap	Pno	116	S6 Flat mf R	Ap	Pno	195	DX1	Kb	FM	274	Timpani2 Med R+	Cp	Malet
38	CF3 Flat Hard St	Ap	Pno	117	S6 Flat mf St Pan	Ap	Pno	196	DX2	Kb	FM	275	Timpani2 Med St-	Cp	Malet
39	CF3 Flat Hard Mn	Ap	Pno	118	S6 Flat mf St+	Ap	Pno	197	DX3	Kb	FM	276	Timpani2 Med L-	Cp	Malet
40	CF3 Flat Hard St+	Ap	Pno	119	S6 Flat mf Mn+	Ap	Pno	198	DX4	Kb	FM	277	Timpani2 Med R	Cp	Malet
41	CF3 Flat Hard Mn+	Ap	Pno	120	S6 Flat mf St-	Ap	Pno	199	DX Body Soft	Kb	FM	278	Timpani2 Hard St	Cp	Malet
42	CF3 Flat Hard St-	Ap	Pno	121	S6 Flat mf Mn-	Ap	Pno	200	DX Body Med	Kb	FM	279	Timpani2 Hard L	Cp	Malet
43	CF3 Flat Hard Mn-	Ap	Pno	122	S6 Flat ff St	Ap	Pno	201	DX Body Hard	Kb	FM	280	Timpani2 Hard R	Cp	Malet
44	S6 Stretch pp St	Ap	Pno	123	S6 Flat ff Mn	Ap	Pno	202	DX Attack1	Kb	FM	281	Timpani2 Hard St+	Cp	Malet
45	S6 Stretch pp Mn	Ap	Pno	124	S6 Flat ff L	Ap	Pno	203	DX Attack2	Kb	FM	282	Timpani2 Hard L+	Cp	Malet
46	S6 Stretch pp L	Ap	Pno	125	S6 Flat ff R	Ap	Pno	204	DX Attack3	Kb	FM	283	Timpani2 Hard R+	Cp	Malet
47	S6 Stretch pp R	Ap	Pno	126	S6 Flat ff St Pan	Ap	Pno	205	DX Attack4	Kb	FM	284	Timpani2 Hard St-	Cp	Malet
48	S6 Stretch pp St Pan	Ap	Pno	127	S6 Flat ff St+	Ap	Pno	206	DX Attack5	Kb	FM	285	Timpani2 Hard L	Cp	Malet
49	S6 Stretch pp St+	Ap	Pno	128	S6 Flat ff Mn+	Ap	Pno	207	Clav1	Kb	Clavi	286	Timpani2 Hard R-	Cp	Malet
50	S6 Stretch pp Mn+	Ap	Pno	129	S6 Flat ff St-	Ap	Pno	208	Clav1+	Kb	Clavi	287	Timpani2 Muffi St	Cp	Malet
51	S6 Stretch pp St-	Ap	Pno	130	S6 Flat ff Mn-	Ap	Pno	209	Clav1-	Kb	Clavi	288	Timpani2 Muffi L	Cp	Malet
52	S6 Stretch pp Mn-	Ap	Pno	131	S6 Flat Sw St	Ap	Pno	210	Clav2	Kb	Clavi	289	Timpani2 Muffi R	Cp	Malet
53	S6 Stretch mp St	Ap	Pno	132	S6 Flat Sw Mn	Ap	Pno	211	Clav2+	Kb	Clavi	290	Timpani2 Oct Soft St	Cp	Malet
54	S6 Stretch mp Mn	Ap	Pno	133	S6 Flat Sw L	Ap	Pno	212	Clav2-	Kb	Clavi	291	Timpani2 Oct Soft L	Cp	Malet
55	S6 Stretch mp L	Ap	Pno	134	S6 Flat Sw R	Ap	Pno	213	Clav3	Kb	Clavi	292	Timpani2 Oct Soft R	Cp	Malet
56	S6 Stretch mp R	Ap	Pno	135	S6 Flat Sw St Pan	Ap	Pno	214	Clav3+	Kb	Clavi	293	Timpani2 Oct Soft L+	Cp	Malet
57	S6 Stretch mp St Pan	Ap	Pno	136	S6 Flat Sw Sl2	Ap	Pno	215	Clav3-	Kb	Clavi	294	Timpani2 Oct Soft L-	Cp	Malet
58	S6 Stretch mp St+	Ap	Pno	137	S6 Flat Sw St+	Ap	Pno	216	Clav4 Med	Kb	Clavi	295	Timpani2 Oct Soft R+	Cp	Malet
59	S6 Stretch mp Mn+	Ap	Pno	138	S6 Flat Sw Mn+	Ap	Pno	217	Clav4 Med +	Kb	Clavi	296	Timpani2 Oct Soft St-	Cp	Malet
60	S6 Stretch mp St-	Ap	Pno	139	S6 Flat Sw St-	Ap	Pno	218	Clav4 Med -	Kb	Clavi	297	Timpani2 Oct Soft L-	Cp	Malet
61	S6 Stretch mp Mn-	Ap	Pno	140	S6 Flat Sw Mn-	Ap	Pno	219	Clav4 Hard	Kb	Clavi	298	Timpani2 Oct Soft R-	Cp	Malet
62	S6 Stretch mf St	Ap	Pno	141	S6 Flat KeyOff St	Ap	Pno	220	Clav4 Hard +	Kb	Clavi	299	Timpani2 Oct Med St	Cp	Malet
63	S6 Stretch mf Mn	Ap	Pno	142	S6 Flat KeyOff Mn	Ap	Pno	221	Clav4 Hard -	Kb	Clavi	300	Timpani2 Oct Med L	Cp	Malet
64	S6 Stretch mf L	Ap	Pno	143	S6 Flat KeyOff L	Ap	Pno	222	Clav Key Off 1	Kb	Clavi	301	Timpani2 Oct Med R	Cp	Malet
65	S6 Stretch mf R	Ap	Pno	144	S6 Flat KeyOff R	Ap	Pno	223	Clav Key Off 2	Kb	Clavi	302	Timpani2 Oct Med St+	Cp	Malet
66	S6 Stretch mf St Pan	Ap	Pno	145	S6 Flat KeyOff StPan	Ap	Pno	224	Harpsichord1	Kb	Other	303	Timpani2 Oct Med L+	Cp	Malet
67	S6 Stretch mf St+	Ap	Pno	146	Brite Piano	Ap	Pno	225	Harpsichord2 St	Kb	Other	304	Timpani2 Oct Med R+	Cp	Malet
68	S6 Stretch mf Mn+	Ap	Pno	147	Brite Piano-	Ap	Pno	226	Harpsichord2 L	Kb	Other	305	Timpani2 Oct Med St-	Cp	Malet
69	S6 Stretch mf St-	Ap	Pno	148	EP1 Sw	Kb	Rds	227	Harpsichord2 R	Kb	Other	306	Timpani2 Oct Med L-	Cp	Malet
70	S6 Stretch mf Mn-	Ap	Pno	149	EP1 Soft	Kb	Rds	228	Harpsichord2 St+	Kb	Other	307	Timpani2 Oct Med R-	Cp	Malet
71	S6 Stretch ff St	Ap	Pno	150	EP1 Soft+	Kb	Rds	229	Harpsichord2 L+	Kb	Other	308	Timpani2 Oct Hard St	Cp	Malet
72	S6 Stretch ff Mn	Ap	Pno	151	EP1 Soft-	Kb	Rds	230	Harpsichord2 R+	Kb	Other	309	Timpani2 Oct Hard L	Cp	Malet
73	S6 Stretch ff L	Ap	Pno	152	EP1 Med	Kb	Rds	231	Harpsichord2 St-	Kb	Other	310	Timpani2 Oct Hard R	Cp	Malet
74	S6 Stretch ff R	Ap	Pno	153	EP1 Med+	Kb	Rds	232	Harpsichord2 L-	Kb	Other	311	Timpani2 Oct Hard St+	Cp	Malet
75	S6 Stretch ff St Pan	Ap	Pno	154	EP1 Med-	Kb	Rds	233	Harpsichord2 R-	Kb	Other	312	Timpani2 Oct Hard L+	Cp	Malet
76	S6 Stretch ff St+	Ap	Pno	155	EP1 Hard	Kb	Rds	234	Harpsichord2 KOI St	Kb	Other	313	Timpani2 Oct Hard R+	Cp	Malet
77	S6 Stretch ff Mn+	Ap	Pno	156	EP1 Hard+	Kb	Rds	235	Harpsichord2 KOI L	Kb	Other	314	Timpani2 Oct Hard St-	Cp	Malet
78	S6 Stretch ff St-	Ap	Pno	157	EP1 Hard-	Kb	Rds	236	Harpsichord2 KOI R	Kb	Other	315	Timpani2 Oct Hard L-	Cp	Malet
79	S6 Stretch ff Mn-	Ap	Pno	158	EP2 Sw	Kb	Rds	237	CP70	Kb	Other	316	Timpani2 Oct Hard R-	Cp	Malet

No.	Name	Main Category	Sub Category	No.	Name	Main Category	Sub Category	No.	Name	Main Category	Sub Category	No.	Name	Main Category	Sub Category
317	Timpani2 Oct Muffl St	Cp	Malet	396	Rotor Grif1	Or	TrnWhl	475	Steel Open Sw St	Gt	A.Gtr	554	Vintage Amp1	Gt	E.Cln
318	Timpani2 Oct Muffl L	Cp	Malet	397	Rotor Grif2	Or	TrnWhl	476	Steel Open Sw L	Gt	A.Gtr	555	Vintage Amp2	Gt	E.Cln
319	Timpani2 Oct Muffl R	Cp	Malet	398	Compact Electronic	Or	Other	477	Steel Open Sw R	Gt	A.Gtr	556	Neck Pickup	Gt	E.Cln
320	Tubular Bell1	Cp	Other	399	Compact Electronic-	Or	Other	478	Steel Open Sw Kb St	Gt	A.Gtr	557	Distortion Open	Gt	E.Dst
321	Tubular Bell2	Cp	Other	400	Portable Electronic	Or	Other	479	Steel Open Sw Kb L	Gt	A.Gtr	558	Distortion Harmonics	Gt	E.Dst
322	Bell	Cp	Other	401	Portable Electronic-	Or	Other	480	Steel Open Sw Kb R	Gt	A.Gtr	559	Distortion Mute	Gt	E.Dst
323	Bell St1	Cp	Other	402	Fr All Tabs	Or	Other	481	Steel Hammer On St	Gt	A.Gtr	560	Overdrive Open	Gt	E.Dst
324	Bell St2	Cp	Other	403	Fr Bright Boost	Or	Other	482	Steel Hammer On L	Gt	A.Gtr	561	Powerdrive Mute	Gt	E.Dst
325	Brass Bell	Cp	Other	404	Fr Flute	Or	Other	483	Steel Hammer On R	Gt	A.Gtr	562	Distortion FX	Gt	E.Dst
326	Small Bell	Cp	Other	405	Fr String Lo	Or	Other	484	Steel Slide St	Gt	A.Gtr	563	Dist/Overdrive FX	Gt	E.Dst
327	Finger Cymbal	Cp	Other	406	Fr String Hi	Or	Other	485	Steel Slide L	Gt	A.Gtr	564	Feedback	Gt	E.Dst
328	Hand Bell	Cp	Other	407	Fr Trumpet	Or	Other	486	Steel Slide R	Gt	A.Gtr	565	Power Chord St	Gt	E.Dst
329	Hibashi	Cp	Other	408	Fr Piccolo	Or	Other	487	Steel Harmonics St	Gt	A.Gtr	566	Power Chord Mono	Gt	E.Dst
330	Stone Hard	Cp	Other	409	Fr Pedal	Or	Other	488	Steel Harmonics L	Gt	A.Gtr	567	Play FX Mix	Gt	E.Dst
331	Stone Soft	Cp	Other	410	Fr KeyOff	Or	Other	489	Steel Harmonics R	Gt	A.Gtr	568	Power Chord FX St	Gt	E.Dst
332	Wood Bell1	Cp	Other	411	Vx Drawbar1-3	Or	Other	490	Steel Mute St	Gt	A.Gtr	569	Power Chord FX Mono	Gt	E.Dst
333	Wood Bell2	Cp	Other	412	Vx DrawbarIV	Or	Other	491	Steel Mute L	Gt	A.Gtr	570	Banjo1	Gt	Ethnc
334	Kalimba	Cp	Other	413	Vx KeyOff	Or	Other	492	Steel Mute R	Gt	A.Gtr	571	Banjo2 Med	Gt	Ethnc
335	Gamelan1	Cp	Other	414	Pipe Organ1 St	Or	Other	493	Steel Dead Notes St	Gt	A.Gtr	572	Banjo2 Med+	Gt	Ethnc
336	Gamelan2	Cp	Other	415	Pipe Organ1 L	Or	Other	494	Steel Dead Notes L	Gt	A.Gtr	573	Banjo2 Med-	Gt	Ethnc
337	Steel Drum	Cp	Other	416	Pipe Organ1 R	Or	Other	495	Steel Dead Notes R	Gt	A.Gtr	574	Banjo2 Hard	Gt	Ethnc
338	Rock Chorus Vibrato	Or	TrnWhl	417	Pipe Organ2	Or	Other	496	Steel FX St	Gt	A.Gtr	575	Banjo2 Hard+	Gt	Ethnc
339	Rock Percussion	Or	TrnWhl	418	Pipe Organ3 St	Or	Other	497	Steel FX L	Gt	A.Gtr	576	Banjo2 Hard-	Gt	Ethnc
340	Rock2	Or	TrnWhl	419	Pipe Organ3 L	Or	Other	498	Steel FX R	Gt	A.Gtr	577	Sitar1	Gt	Ethnc
341	Rock2+	Or	TrnWhl	420	Pipe Organ3 R	Or	Other	499	High Strings Soft St	Gt	A.Gtr	578	Sitar2 Soft	Gt	Ethnc
342	Rock2-	Or	TrnWhl	421	Pipe Organ4	Or	Other	500	High Strings Soft L	Gt	A.Gtr	579	Sitar2 Soft+	Gt	Ethnc
343	Jazz w/Percussion	Or	TrnWhl	422	Pipe Organ5	Or	Other	501	High Strings Soft R	Gt	A.Gtr	580	Sitar2 Soft-	Gt	Ethnc
344	Jazz w/Percussion-	Or	TrnWhl	423	Harmonium Side	Or	Other	502	High Strings Hard St	Gt	A.Gtr	581	Sitar2 Med	Gt	Ethnc
345	Jazz	Or	TrnWhl	424	Harmonium Main	Or	Other	503	High Strings Hard L	Gt	A.Gtr	582	Sitar2 Med+	Gt	Ethnc
346	Jazz+	Or	TrnWhl	425	Accordion1	Or	Other	504	High Strings Hard R	Gt	A.Gtr	583	Sitar2 Med-	Gt	Ethnc
347	Jazz-	Or	TrnWhl	426	Accordion2	Or	Other	505	High Strings FX St	Gt	A.Gtr	584	Sitar2 Hard	Gt	Ethnc
348	Full Draw	Or	TrnWhl	427	Accordion3	Or	Other	506	High Strings FX L	Gt	A.Gtr	585	Sitar2 Hard+	Gt	Ethnc
349	Full Draw+	Or	TrnWhl	428	Tango Accordion1	Or	Other	507	High Strings FX R	Gt	A.Gtr	586	Sitar2 Hard-	Gt	Ethnc
350	Full Draw-	Or	TrnWhl	429	Tango Accordion2	Or	Other	508	High Strings FX2 St	Gt	A.Gtr	587	Sitar Waves1	Gt	Ethnc
351	Swish	Or	TrnWhl	430	Tango Accordion Bass	Or	Other	509	Clean Open Med	Gt	E.Cln	588	Sitar Waves2	Gt	Ethnc
352	Swish-	Or	TrnWhl	431	Mussete Accordion	Or	Other	510	Clean Open Hard	Gt	E.Cln	589	Sitar Waves3	Gt	Ethnc
353	Bow	Or	TrnWhl	432	Steirisch Accordion	Or	Other	511	Clean Open Sw	Gt	E.Cln	590	Sitar Waves4	Gt	Ethnc
354	Bow Chorus Vibrato	Or	TrnWhl	433	Nylon Open Soft St	Gt	A.Gtr	512	Clean Open Sw Kb	Gt	E.Cln	591	Sitar Waves5	Gt	Ethnc
355	Gospel	Or	TrnWhl	434	Nylon Open Soft L	Gt	A.Gtr	513	Clean Hammer On	Gt	E.Cln	592	Sitar Waves6	Gt	Ethnc
356	Soul	Or	TrnWhl	435	Nylon Open Soft R	Gt	A.Gtr	514	Clean Slap	Gt	E.Cln	593	Tambura	Gt	Ethnc
357	1st Four Draw	Or	TrnWhl	436	Nylon Open Med St	Gt	A.Gtr	515	Clean Slide	Gt	E.Cln	594	Tambura Waves1	Gt	Ethnc
358	Draw 16'	Or	TrnWhl	437	Nylon Open Med L	Gt	A.Gtr	516	Clean Harmonics	Gt	E.Cln	595	Tambura Waves2	Gt	Ethnc
359	Draw 5 1/3	Or	TrnWhl	438	Nylon Open Med R	Gt	A.Gtr	517	Clean Mute	Gt	E.Cln	596	Tambura Waves3	Gt	Ethnc
360	Draw 8'	Or	TrnWhl	439	Nylon Open Hard St	Gt	A.Gtr	518	Clean Dead	Gt	E.Cln	597	Santur	Gt	Ethnc
361	Draw 4'	Or	TrnWhl	440	Nylon Open Hard L	Gt	A.Gtr	519	Clean FX	Gt	E.Cln	598	Ud	Gt	Ethnc
362	Draw 2 2/3	Or	TrnWhl	441	Nylon Open Hard R	Gt	A.Gtr	520	60s Clean Open Soft	Gt	E.Cln	599	Kanun	Gt	Ethnc
363	Draw 2'	Or	TrnWhl	442	Nylon Open Sw St	Gt	A.Gtr	521	60s Clean Open Med	Gt	E.Cln	600	Baglama	Gt	Ethnc
364	Draw 1 3/5	Or	TrnWhl	443	Nylon Open Sw L	Gt	A.Gtr	522	60s Clean Open Hard	Gt	E.Cln	601	Bouzouki	Gt	Ethnc
365	Draw 1 1/3	Or	TrnWhl	444	Nylon Open Sw R	Gt	A.Gtr	523	60s Clean Open Sw	Gt	E.Cln	602	Shamisen	Gt	Ethnc
366	Draw 1'	Or	TrnWhl	445	Nylon Open Sw Kb St	Gt	A.Gtr	524	60s Clean Open Sw Kb	Gt	E.Cln	603	Koto	Gt	Ethnc
367	Draw 16' Of	Or	TrnWhl	446	Nylon Open Sw Kb L	Gt	A.Gtr	525	60s Clean Open Sw2	Gt	E.Cln	604	Acoustic Med	Ba	ABass
368	Draw 5 1/3 Of	Or	TrnWhl	447	Nylon Open Sw Kb R	Gt	A.Gtr	526	60s Clean Dead	Gt	E.Cln	605	Acoustic Hard	Ba	ABass
369	Draw 8' Of	Or	TrnWhl	448	Nylon Dead Notes St	Gt	A.Gtr	527	60s Clean Mute	Gt	E.Cln	606	Acoustic Harmonics	Ba	ABass
370	Draw 4' Of	Or	TrnWhl	449	Nylon Dead Notes L	Gt	A.Gtr	528	60s Clean Hammer On	Gt	E.Cln	607	Acoustic Dead	Ba	ABass
371	Draw 2 2/3 Of	Or	TrnWhl	450	Nylon Dead Notes R	Gt	A.Gtr	529	60s Clean Slide	Gt	E.Cln	608	Acoustic FX1	Ba	ABass
372	Draw 2' Of	Or	TrnWhl	451	Nylon Mute St	Gt	A.Gtr	530	60s Clean Harmonics	Gt	E.Cln	609	Acoustic FX2	Ba	ABass
373	Draw 1 3/5 Of	Or	TrnWhl	452	Nylon Mute L	Gt	A.Gtr	531	60s Clean FX	Gt	E.Cln	610	Acoustic Med+	Ba	ABass
374	Draw 1 1/3 Of	Or	TrnWhl	453	Nylon Mute R	Gt	A.Gtr	532	60s Clean Slap	Gt	E.Cln	611	Acoustic Hard+	Ba	ABass
375	Draw 1' Of	Or	TrnWhl	454	Nylon Hammer On St	Gt	A.Gtr	533	1Coil Open Sw	Gt	E.Cln	612	Acoustic Med-	Ba	ABass
376	Draw 1+3	Or	TrnWhl	455	Nylon Hammer On L	Gt	A.Gtr	534	1Coil Open Soft	Gt	E.Cln	613	Acoustic Hard-	Ba	ABass
377	Draw 1+3+	Or	TrnWhl	456	Nylon Hammer On R	Gt	A.Gtr	535	1Coil Open Med	Gt	E.Cln	614	Pick Open	Ba	EBass
378	Draw 1+3-	Or	TrnWhl	457	Nylon Slide St	Gt	A.Gtr	536	1Coil Open Hard	Gt	E.Cln	615	Pick Harmonics	Ba	EBass
379	Draw 2+4	Or	TrnWhl	458	Nylon Slide L	Gt	A.Gtr	537	1Coil Dead	Gt	E.Cln	616	Pick Mute	Ba	EBass
380	Draw 2+4+	Or	TrnWhl	459	Nylon Slide R	Gt	A.Gtr	538	1Coil Mute	Gt	E.Cln	617	Pick Dead	Ba	EBass
381	Draw 2+4-	Or	TrnWhl	460	Nylon Harmonics St	Gt	A.Gtr	539	1Coil Hammer On	Gt	E.Cln	618	Pick Open+	Ba	EBass
382	Draw Even	Or	TrnWhl	461	Nylon Harmonics L	Gt	A.Gtr	540	1Coil Slide	Gt	E.Cln	619	Pick Mute+	Ba	EBass
383	Draw Even+	Or	TrnWhl	462	Nylon Harmonics R	Gt	A.Gtr	541	1Coil Harmonics	Gt	E.Cln	620	Pick Open-	Ba	EBass
384	Draw Even-	Or	TrnWhl	463	Nylon FX St	Gt	A.Gtr	542	1Coil FX	Gt	E.Cln	621	Pick Mute-	Ba	EBass
385	Draw Odd	Or	TrnWhl	464	Nylon FX L	Gt	A.Gtr	543	Jazz Guitar	Gt	E.Cln	622	Pick Rndwound1 Med	Ba	EBass
386	Draw Odd+	Or	TrnWhl	465	Nylon FX R	Gt	A.Gtr	544	Jazz Open Soft	Gt	E.Cln	623	Pick Rndwound1 Hard	Ba	EBass
387	Draw Odd-	Or	TrnWhl	466	Steel Open Soft St	Gt	A.Gtr	545	Jazz Open Med	Gt	E.Cln	624	Pick Rndwound1 Med+	Ba	EBass
388	Percussion	Or	TrnWhl	467	Steel Open Soft L	Gt	A.Gtr	546	Jazz Open Hard	Gt	E.Cln	625	Pick Rndwound1 Hard+	Ba	EBass
389	Percussion+	Or	TrnWhl	468	Steel Open Soft R	Gt	A.Gtr	547	Jazz Open Sw	Gt	E.Cln	626	Pick Rndwound1 Med-	Ba	EBass
390	Percussion-	Or	TrnWhl	469	Steel Open Med St	Gt	A.Gtr	548	Jazz Dead Med	Gt	E.Cln	627	Pick Rndwound1 Hard-	Ba	EBass
391	Tonewheel Key Click	Or	TrnWhl	470	Steel Open Med L	Gt	A.Gtr	549	Jazz Dead Hard	Gt	E.Cln	628	Pick Rndwound2 Open	Ba	EBass
392	Clack 1	Or	TrnWhl	471	Steel Open Med R	Gt	A.Gtr	550	Jazz Hammer On	Gt	E.Cln	629	Pick Rndwound2 Open+	Ba	EBass
393	Clack 2	Or	TrnWhl	472	Steel Open Hard St	Gt	A.Gtr	551	Jazz Slide	Gt	E.Cln	630	Pick Rndwound2 Open-	Ba	EBass
394	Rotor	Or	TrnWhl	473	Steel Open Hard L	Gt	A.Gtr	552	Jazz Harmonics	Gt	E.Cln	631	Pick Rndwound2 Mute	Ba	EBass
395	Rotor Whistle	Or	TrnWhl	474	Steel Open Hard R	Gt	A.Gtr	553	Jazz FX	Gt	E.Cln	632	Pick Rndwound2 Mute+	Ba	EBass

No.	Name	Main Category	Sub Category	No.	Name	Main Category	Sub Category	No.	Name	Main Category	Sub Category	No.	Name	Main Category	Sub Category
633	Pick Rndwound2 Mute-	Ba	EBass	712	Contrabass R	St	Solo	791	OrchStrgs Med L	St	Ensem	870	Tremolo Strings L+	St	Ensem
634	Pick Rndwound2 Dead	Ba	EBass	713	Contrabass St+	St	Solo	792	OrchStrgs Med L+	St	Ensem	871	Tremolo Strings R+	St	Ensem
635	Pick Rndwound2 Harm	Ba	EBass	714	Contrabass L+	St	Solo	793	OrchStrgs Med L-	St	Ensem	872	Tremolo Strings St-	St	Ensem
636	Pick Rndwound2 FX	Ba	EBass	715	Contrabass R-	St	Solo	794	OrchStrgs Med R	St	Ensem	873	Tremolo Strings L-	St	Ensem
637	Pick Flatwound	Ba	EBass	716	Contrabass St-	St	Solo	795	OrchStrgs Med R+	St	Ensem	874	Tremolo Strings R-	St	Ensem
638	Pick Flatwound+	Ba	EBass	717	Contrabass L-	St	Solo	796	OrchStrgs Med R-	St	Ensem	875	Tremolo StringsSt Of	St	Ensem
639	Pick Flatwound-	Ba	EBass	718	Contrabass R-	St	Solo	797	OrchStrgs Med St Of	St	Ensem	876	Tremolo Strings L Of	St	Ensem
640	Finger Med	Ba	EBass	719	Contrabass St Of	St	Solo	798	OrchStrgs Med L Of	St	Ensem	877	Tremolo Strings R Of	St	Ensem
641	Finger Hard	Ba	EBass	720	Contrabass L Of	St	Solo	799	OrchStrgs Med R Of	St	Ensem	878	Pizzicato1 St	St	Pizz
642	Finger Harmonics	Ba	EBass	721	Contrabass R Of	St	Solo	800	OrchStrgs Hard St	St	Ensem	879	Pizzicato1 Mono	St	Pizz
643	Finger Med+	Ba	EBass	722	Solo Combi St	St	Solo	801	OrchStrgs Hard St+	St	Ensem	880	Pizzicato2	St	Pizz
644	Finger Hard+	Ba	EBass	723	Solo Combi L	St	Solo	802	OrchStrgs Hard St-	St	Ensem	881	Pop Pizzicato	St	Pizz
645	Finger Med-	Ba	EBass	724	Solo Combi R	St	Solo	803	OrchStrgs Hard L	St	Ensem	882	Large Pizzicato St	St	Pizz
646	Finger Hard-	Ba	EBass	725	Solo Combi St+	St	Solo	804	OrchStrgs Hard L+	St	Ensem	883	Large Pizzicato L	St	Pizz
647	Finger Dead	Ba	EBass	726	Solo Combi L+	St	Solo	805	OrchStrgs Hard L-	St	Ensem	884	Large Pizzicato R	St	Pizz
648	Finger Rndwound St	Ba	EBass	727	Solo Combi R+	St	Solo	806	OrchStrgs Hard R	St	Ensem	885	Large Pizzicato St+	St	Pizz
649	Finger Rndwound St+	Ba	EBass	728	Solo Combi St-	St	Solo	807	OrchStrgs Hard R+	St	Ensem	886	Large Pizzicato L+	St	Pizz
650	Finger Rndwound St-	Ba	EBass	729	Solo Combi L-	St	Solo	808	OrchStrgs Hard R-	St	Ensem	887	Large Pizzicato R+	St	Pizz
651	Finger Rndwound Hrd	Ba	EBass	730	Solo Combi R-	St	Solo	809	OrchStrgs Hard St Of	St	Ensem	888	Large Pizzicato St-	St	Pizz
652	Finger Rndwound Hrd+	Ba	EBass	731	Solo Combi St Of	St	Solo	810	OrchStrgs Hard L Of	St	Ensem	889	Large Pizzicato L-	St	Pizz
653	Finger Rndwound Hrd-	Ba	EBass	732	Solo Combi L Of	St	Solo	811	OrchStrgs Hard R Of	St	Ensem	890	Large Pizzicato R-	St	Pizz
654	Finger Rndwound Dead	Ba	EBass	733	Solo Combi R Of	St	Solo	812	Sect Strgs Soft St	St	Ensem	891	Live Pizzct Soft St	St	Pizz
655	Finger Rndwound Harm	Ba	EBass	734	Solo Combi2 St	St	Solo	813	Sect Strgs Soft L	St	Ensem	892	Live Pizzct Soft L	St	Pizz
656	Thumb/Pull Hard	Ba	EBass	735	Solo Combi2 L	St	Solo	814	Sect Strgs Soft R	St	Ensem	893	Live Pizzct Soft R	St	Pizz
657	Thumb Hard	Ba	EBass	736	Solo Combi2 R	St	Solo	815	Sect Strgs Soft St+	St	Ensem	894	Live Pizzct Soft St+	St	Pizz
658	Thumb Harmonics	Ba	EBass	737	Solo Combi2 St Of	St	Solo	816	Sect Strgs Soft L+	St	Ensem	895	Live Pizzct Soft L+	St	Pizz
659	Thumb Soft	Ba	EBass	738	Solo Combi2 L Of	St	Solo	817	Sect Strgs Soft R+	St	Ensem	896	Live Pizzct Soft R+	St	Pizz
660	Thumb Dead	Ba	EBass	739	Solo Combi2 R Of	St	Solo	818	Sect Strgs Soft St-	St	Ensem	897	Live Pizzct Soft St-	St	Pizz
661	Pull Dead	Ba	EBass	740	Solo Combi3 St	St	Solo	819	Sect Strgs Soft L-	St	Ensem	898	Live Pizzct Soft L-	St	Pizz
662	Fretless	Ba	EBass	741	Solo Combi3 L	St	Solo	820	Sect Strgs Soft R-	St	Ensem	899	Live Pizzct Soft R-	St	Pizz
663	Fretless Harmonics	Ba	EBass	742	Solo Combi3 R	St	Solo	821	Sect Strgs SoftSt Of	St	Ensem	900	Live Pizzct Hard St	St	Pizz
664	Fretless+	Ba	EBass	743	Solo Combi3 St Of	St	Solo	822	Sect Strgs Soft L Of	St	Ensem	901	Live Pizzct Hard L	St	Pizz
665	Fretless-	Ba	EBass	744	Solo Combi3 L Of	St	Solo	823	Sect Strgs Soft R Of	St	Ensem	902	Live Pizzct Hard R	St	Pizz
666	Fretless Dead	Ba	EBass	745	Solo Combi3 R Of	St	Solo	824	Sect Strgs Med St	St	Ensem	903	Live Pizzct Hard St+	St	Pizz
667	Electric Bass FX	Ba	EBass	746	Solo Spiccato Combi	St	Solo	825	Sect Strgs Med L	St	Ensem	904	Live Pizzct Hard L+	St	Pizz
668	Violin Non-Vib	St	Solo	747	Solo Spiccato Combi+	St	Solo	826	Sect Strgs Med R	St	Ensem	905	Live Pizzct Hard R+	St	Pizz
669	Violin Non-Vib+	St	Solo	748	Solo Spiccato Combi-	St	Solo	827	Sect Strgs Med St+	St	Ensem	906	Live Pizzct Hard St-	St	Pizz
670	Violin Non-Vib-	St	Solo	749	Keman	St	Solo	828	Sect Strgs Med L+	St	Ensem	907	Live Pizzct Hard L-	St	Pizz
671	Violin Non-Vib Of	St	Solo	750	Keman Of	St	Solo	829	Sect Strgs Med R+	St	Ensem	908	Live Pizzct Hard R-	St	Pizz
672	Violin Non-Vib+ Of	St	Solo	751	Ensemble Mix	St	Ensem	830	Sect Strgs Med St-	St	Ensem	909	Orchestral Harp1	St	Pizz
673	Violin Non-Vib- Of	St	Solo	752	Ensemble Mix St	St	Ensem	831	Sect Strgs Med L-	St	Ensem	910	Orch Harp2 Soft St	St	Pizz
674	Violin St	St	Solo	753	Ensemble Mix L	St	Ensem	832	Sect Strgs Med R-	St	Ensem	911	Orch Harp2 Soft L	St	Pizz
675	Violin L	St	Solo	754	Ensemble Mix R	St	Ensem	833	Sect Strgs Med St Of	St	Ensem	912	Orch Harp2 Soft R	St	Pizz
676	Violin R	St	Solo	755	Ensemble Mix St Of	St	Ensem	834	Sect Strgs Med L Of	St	Ensem	913	Orch Harp2 Soft St+	St	Pizz
677	Violin St+	St	Solo	756	Ensemble Mix L Of	St	Ensem	835	Sect Strgs Med R Of	St	Ensem	914	Orch Harp2 Soft L+	St	Pizz
678	Violin L+	St	Solo	757	Ensemble Mix R Of	St	Ensem	836	Sect Strgs Hard St	St	Ensem	915	Orch Harp2 Soft R+	St	Pizz
679	Violin R+	St	Solo	758	Ensemble Mute St	St	Ensem	837	Sect Strgs Hard L	St	Ensem	916	Orch Harp2 Soft St-	St	Pizz
680	Violin St-	St	Solo	759	Ensemble Mute	St	Ensem	838	Sect Strgs Hard R	St	Ensem	917	Orch Harp2 Soft L-	St	Pizz
681	Violin L-	St	Solo	760	Ensemble Mute-	St	Ensem	839	Sect Strgs Hard St+	St	Ensem	918	Orch Harp2 Soft R-	St	Pizz
682	Violin R-	St	Solo	761	Ensemble Mute St Of	St	Ensem	840	Sect Strgs Hard L+	St	Ensem	919	Orch Harp2 Med St	St	Pizz
683	Violin St Of	St	Solo	762	Ensemble Mute Of	St	Ensem	841	Sect Strgs Hard R+	St	Ensem	920	Orch Harp2 Med L	St	Pizz
684	Violin L Of	St	Solo	763	Ensemble Mute - Of	St	Ensem	842	Sect Strgs Hard St-	St	Ensem	921	Orch Harp2 Med R	St	Pizz
685	Violin R Of	St	Solo	764	Hard Ensemble St	St	Ensem	843	Sect Strgs Hard L-	St	Ensem	922	Orch Harp2 Med St+	St	Pizz
686	Viola St	St	Solo	765	Hard Ensemble St+	St	Ensem	844	Sect Strgs Hard R-	St	Ensem	923	Orch Harp2 Med L+	St	Pizz
687	Viola L	St	Solo	766	Hard Ensemble St-	St	Ensem	845	Sect Strgs Hard StOf	St	Ensem	924	Orch Harp2 Med R+	St	Pizz
688	Viola R	St	Solo	767	Hard Ensemble L	St	Ensem	846	Sect Strgs Hard L Of	St	Ensem	925	Orch Harp2 Med St-	St	Pizz
689	Viola St+	St	Solo	768	Hard Ensemble L+	St	Ensem	847	Sect Strgs Hard R Of	St	Ensem	926	Orch Harp2 Med L-	St	Pizz
690	Viola L+	St	Solo	769	Hard Ensemble L-	St	Ensem	848	Sect Strgs Gliss St	St	Ensem	927	Orch Harp2 Med R-	St	Pizz
691	Viola R+	St	Solo	770	Hard Ensemble R	St	Ensem	849	Sect Strgs Gliss L	St	Ensem	928	Trumpet1 Med	Br	Solo
692	Viola St-	St	Solo	771	Hard Ensemble R+	St	Ensem	850	Sect Strgs Gliss R	St	Ensem	929	Trumpet1 Hard	Br	Solo
693	Viola L-	St	Solo	772	Hard Ensemble R-	St	Ensem	851	Sect Strgs Gliss St+	St	Ensem	930	Trumpet1 Med Of	Br	Solo
694	Viola R-	St	Solo	773	Hard Ensemble St Of	St	Ensem	852	Sect Strgs Gliss L+	St	Ensem	931	Trumpet1 Hard Of	Br	Solo
695	Viola St Of	St	Solo	774	Hard Ensemble L Of	St	Ensem	853	Sect Strgs Gliss R+	St	Ensem	932	Trumpet2	Br	Solo
696	Viola L Of	St	Solo	775	Hard Ensemble R Of	St	Ensem	854	Sect Strgs Gliss St-	St	Ensem	933	Trumpet2+	Br	Solo
697	Viola R Of	St	Solo	776	OrchStrgs Soft St	St	Ensem	855	Sect Strgs Gliss L-	St	Ensem	934	Trumpet2-	Br	Solo
698	Cello St	St	Solo	777	OrchStrgs Soft St+	St	Ensem	856	Sect Strgs Gliss R-	St	Ensem	935	Trumpet2 Of	Br	Solo
699	Cello L	St	Solo	778	OrchStrgs Soft St-	St	Ensem	857	Sect Strgs Spicc St	St	Ensem	936	Trumpet Mute	Br	Solo
700	Cello R	St	Solo	779	OrchStrgs Soft L	St	Ensem	858	Sect Strgs Spicc L	St	Ensem	937	Trumpet Mute Of	Br	Solo
701	Cello St+	St	Solo	780	OrchStrgs Soft L+	St	Ensem	859	Sect Strgs Spicc R	St	Ensem	938	Soft Trumpet Soft	Br	Solo
702	Cello L+	St	Solo	781	OrchStrgs Soft L-	St	Ensem	860	Sect Strgs Spicc St+	St	Ensem	939	Soft Trumpet Soft+	Br	Solo
703	Cello R+	St	Solo	782	OrchStrgs Soft R	St	Ensem	861	Sect Strgs Spicc L+	St	Ensem	940	Soft Trumpet Soft-	Br	Solo
704	Cello St-	St	Solo	783	OrchStrgs Soft R+	St	Ensem	862	Sect Strgs Spicc R+	St	Ensem	941	Soft Trumpet Soft Of	Br	Solo
705	Cello L-	St	Solo	784	OrchStrgs Soft R-	St	Ensem	863	Sect Strgs Spicc St-	St	Ensem	942	Soft Trumpet Med	Br	Solo
706	Cello R-	St	Solo	785	OrchStrgs Soft St Of	St	Ensem	864	Sect Strgs Spicc L-	St	Ensem	943	Soft Trumpet Med+	Br	Solo
707	Cello St Of	St	Solo	786	OrchStrgs Soft L Of	St	Ensem	865	Sect Strgs Spicc R-	St	Ensem	944	Soft Trumpet Med-	Br	Solo
708	Cello L Of	St	Solo	787	OrchStrgs Soft R Of	St	Ensem	866	Tremolo Strings St	St	Ensem	945	Soft Trumpet Med Of	Br	Solo
709	Cello R Of	St	Solo	788	OrchStrgs Med St	St	Ensem	867	Tremolo Strings L	St	Ensem	946	Trumpet Vib Soft	Br	Solo
710	Contrabass St	St	Solo	789	OrchStrgs Med St+	St	Ensem	868	Tremolo Strings R	St	Ensem	947	Trumpet Vib Soft+	Br	Solo
711	Contrabass L	St	Solo	790	OrchStrgs Med St-	St	Ensem	869	Tremolo Strings St+	St	Ensem	948	Trumpet Vib Soft-	Br	Solo

No.	Name	Main Category	Sub Category	No.	Name	Main Category	Sub Category	No.	Name	Main Category	Sub Category	No.	Name	Main Category	Sub Category
949	Trumpet Vib Soft Of	Br	Solo	1028	Brass Sect2 Med SIOf	Br	Ensem	1107	Tenor Sax2 Hard	Rd	Sax	1186	Bassoon Med St+	Rd	Orche
950	Trumpet Vib Med	Br	Solo	1029	Brass Sect2 Med L Of	Br	Ensem	1108	Tenor Sax2 Hard+	Rd	Sax	1187	Bassoon Med St-	Rd	Orche
951	Trumpet Vib Med+	Br	Solo	1030	Brass Sect2 Med R Of	Br	Ensem	1109	Tenor Sax2 Hard-	Rd	Sax	1188	Bassoon Med L	Rd	Orche
952	Trumpet Vib Med-	Br	Solo	1031	Brass Sect2 Hard St	Br	Ensem	1110	Tenor Sax2 Hard Of	Rd	Sax	1189	Bassoon Med L+	Rd	Orche
953	Trumpet Vib Med Of	Br	Solo	1032	Brass Sect2 Hard St+	Br	Ensem	1111	Tenor Sax2 Growl	Rd	Sax	1190	Bassoon Med L-	Rd	Orche
954	Trumpet Vib Hard	Br	Solo	1033	Brass Sect2 Hard St-	Br	Ensem	1112	Tenor Sax2 Growl+	Rd	Sax	1191	Bassoon Med R	Rd	Orche
955	Trumpet Vib Hard+	Br	Solo	1034	Brass Sect2 Hard L	Br	Ensem	1113	Tenor Sax2 Growl-	Rd	Sax	1192	Bassoon Med R+	Rd	Orche
956	Trumpet Vib Hard-	Br	Solo	1035	Brass Sect2 Hard L+	Br	Ensem	1114	Tenor Sax2 Growl Of	Rd	Sax	1193	Bassoon Med R-	Rd	Orche
957	Trumpet Vib Hard Of	Br	Solo	1036	Brass Sect2 Hard L-	Br	Ensem	1115	Tenor Sax2 Falls	Rd	Sax	1194	Bassoon Med St Of	Rd	Orche
958	Trumpet Shake	Br	Solo	1037	Brass Sect2 Hard R	Br	Ensem	1116	Tenor Sax2 Falls+	Rd	Sax	1195	Bassoon Med L Of	Rd	Orche
959	Trumpet Shake+	Br	Solo	1038	Brass Sect2 Hard R+	Br	Ensem	1117	Tenor Sax2 Falls-	Rd	Sax	1196	Bassoon Med R Of	Rd	Orche
960	Trumpet Shake-	Br	Solo	1039	Brass Sect2 Hard R-	Br	Ensem	1118	Baritone Sax	Rd	Sax	1197	Bassoon Hard St	Rd	Orche
961	Trumpet Shake Of	Br	Solo	1040	Brass Sect2 Hrd SIOf	Br	Ensem	1119	Baritone Sax Of	Rd	Sax	1198	Bassoon Hard St+	Rd	Orche
962	Trombone1	Br	Solo	1041	Brass Sect2 Hrd L Of	Br	Ensem	1120	Sax Breath	Rd	Sax	1199	Bassoon Hard St-	Rd	Orche
963	Trombone1-	Br	Solo	1042	Brass Sect2 Hrd R Of	Br	Ensem	1121	Clarinet Soft St	Rd	Orche	1200	Bassoon Hard L	Rd	Orche
964	Trombone1 Of	Br	Solo	1043	French Horn Slt St	Br	Ensem	1122	Clarinet Soft St+	Rd	Orche	1201	Bassoon Hard L+	Rd	Orche
965	Trombone1- Of	Br	Solo	1044	French Horn Slt L	Br	Ensem	1123	Clarinet Soft St-	Rd	Orche	1202	Bassoon Hard L-	Rd	Orche
966	Trombone2	Br	Solo	1045	French Horn Slt R	Br	Ensem	1124	Clarinet Soft L	Rd	Orche	1203	Bassoon Hard R	Rd	Orche
967	Trombone2 Of	Br	Solo	1046	French Horn Slt St+	Br	Ensem	1125	Clarinet Soft L+	Rd	Orche	1204	Bassoon Hard R+	Rd	Orche
968	Soft Trombone	Br	Solo	1047	French Horn Slt L+	Br	Ensem	1126	Clarinet Soft L-	Rd	Orche	1205	Bassoon Hard R-	Rd	Orche
969	Soft Trombone Of	Br	Solo	1048	French Horn Slt R+	Br	Ensem	1127	Clarinet Soft R	Rd	Orche	1206	Bassoon Hard St Of	Rd	Orche
970	Soft Flugelhorn	Br	Solo	1049	French Horn Slt St-	Br	Ensem	1128	Clarinet Soft R+	Rd	Orche	1207	Bassoon Hard L Of	Rd	Orche
971	Soft Flugelhorn-	Br	Solo	1050	French Horn Slt L-	Br	Ensem	1129	Clarinet Soft R-	Rd	Orche	1208	Bassoon Hard R Of	Rd	Orche
972	Soft Flugelhorn Of	Br	Solo	1051	French Horn Slt R-	Br	Ensem	1130	Clarinet Soft St Of	Rd	Orche	1209	Bagpipe1	Rd	Other
973	Soft Flugelhorn- Of	Br	Solo	1052	French Horn Slt SIOf	Br	Ensem	1131	Clarinet Soft L Of	Rd	Orche	1210	Bagpipe2	Rd	Other
974	Flugelhorn1	Br	Solo	1053	French Horn Slt L Of	Br	Ensem	1132	Clarinet Soft R Of	Rd	Orche	1211	Harmonica	Rd	Other
975	Flugelhorn1 Of	Br	Solo	1054	French Horn Slt R Of	Br	Ensem	1133	Clarinet Med St	Rd	Orche	1212	Chromatic Harmonica	Rd	Other
976	Flugelhorn2	Br	Solo	1055	French Horn SltSt+Of	Br	Ensem	1134	Clarinet Med St+	Rd	Orche	1213	Blues Harmonica	Rd	Other
977	Flugelhorn2+	Br	Solo	1056	French Horn Slt L+Of	Br	Ensem	1135	Clarinet Med St-	Rd	Orche	1214	Flute Non-Vib	Pi	Orche
978	Flugelhorn2-	Br	Solo	1057	French Horn Slt R+Of	Br	Ensem	1136	Clarinet Med L	Rd	Orche	1215	Flute Non-Vib Of	Pi	Orche
979	Flugelhorn2 Of	Br	Solo	1058	French Horn SltSt-Of	Br	Ensem	1137	Clarinet Med L+	Rd	Orche	1216	Flute1	Pi	Orche
980	French Horn Solo	Br	Solo	1059	French Horn Slt L-Of	Br	Ensem	1138	Clarinet Med L-	Rd	Orche	1217	Flute1 Of	Pi	Orche
981	French Horn Solo+	Br	Solo	1060	French Horn Slt R-Of	Br	Ensem	1139	Clarinet Med R	Rd	Orche	1218	Flute1 Attack	Pi	Orche
982	French Horn Solo-	Br	Solo	1061	French Horn Med St	Br	Ensem	1140	Clarinet Med R+	Rd	Orche	1219	Flute2 Soft St	Pi	Orche
983	French Horn Solo Of	Br	Solo	1062	French Horn Med L	Br	Ensem	1141	Clarinet Med R-	Rd	Orche	1220	Flute2 Soft St+	Pi	Orche
984	French Horn Solo+ Of	Br	Solo	1063	French Horn Med R	Br	Ensem	1142	Clarinet Med St Of	Rd	Orche	1221	Flute2 Soft St-	Pi	Orche
985	French Horn Solo- Of	Br	Solo	1064	French Horn Med St+	Br	Ensem	1143	Clarinet Med L Of	Rd	Orche	1222	Flute2 Soft L	Pi	Orche
986	Tuba	Br	Solo	1065	French Horn Med L+	Br	Ensem	1144	Clarinet Med R Of	Rd	Orche	1223	Flute2 Soft L+	Pi	Orche
987	Tuba Lp	Br	Solo	1066	French Horn Med R+	Br	Ensem	1145	Clarinet Hard St	Rd	Orche	1224	Flute2 Soft L-	Pi	Orche
988	Brass Sect1 St	Br	Ensem	1067	French Horn Med St-	Br	Ensem	1146	Clarinet Hard St+	Rd	Orche	1225	Flute2 Soft R	Pi	Orche
989	Brass Sect1 St+	Br	Ensem	1068	French Horn Med L-	Br	Ensem	1147	Clarinet Hard St-	Rd	Orche	1226	Flute2 Soft R+	Pi	Orche
990	Brass Sect1 St-	Br	Ensem	1069	French Horn Med R-	Br	Ensem	1148	Clarinet Hard L	Rd	Orche	1227	Flute2 Soft R-	Pi	Orche
991	Brass Sect1 L	Br	Ensem	1070	French Horn Med SIOf	Br	Ensem	1149	Clarinet Hard L+	Rd	Orche	1228	Flute2 Soft St Of	Pi	Orche
992	Brass Sect1 L+	Br	Ensem	1071	French Horn Med L Of	Br	Ensem	1150	Clarinet Hard L-	Rd	Orche	1229	Flute2 Soft L Of	Pi	Orche
993	Brass Sect1 L-	Br	Ensem	1072	French Horn Med R Of	Br	Ensem	1151	Clarinet Hard R	Rd	Orche	1230	Flute2 Soft R Of	Pi	Orche
994	Brass Sect1 R	Br	Ensem	1073	French Horn MedSt+Of	Br	Ensem	1152	Clarinet Hard R+	Rd	Orche	1231	Flute2 Med St	Pi	Orche
995	Brass Sect1 R+	Br	Ensem	1074	French Horn Med L+Of	Br	Ensem	1153	Clarinet Hard R-	Rd	Orche	1232	Flute2 Med St+	Pi	Orche
996	Brass Sect1 R-	Br	Ensem	1075	French Horn Med R+Of	Br	Ensem	1154	Clarinet Hard St Of	Rd	Orche	1233	Flute2 Med St-	Pi	Orche
997	Brass Sect1 St Of	Br	Ensem	1076	French Horn MedSt-Of	Br	Ensem	1155	Clarinet Hard L Of	Rd	Orche	1234	Flute2 Med L	Pi	Orche
998	Brass Sect1 St+ Of	Br	Ensem	1077	French Horn Med L-Of	Br	Ensem	1156	Clarinet Hard R Of	Rd	Orche	1235	Flute2 Med L+	Pi	Orche
999	Brass Sect1 St- Of	Br	Ensem	1078	French Horn Med R-Of	Br	Ensem	1157	Oboe1	Rd	Orche	1236	Flute2 Med L-	Pi	Orche
1000	Brass Sect1 L Of	Br	Ensem	1079	Soprano Sax1	Rd	Sax	1158	Oboe1 Of	Rd	Orche	1237	Flute2 Med R	Pi	Orche
1001	Brass Sect1 L+ Of	Br	Ensem	1080	Soprano Sax1 Of	Rd	Sax	1159	Oboe2 Med St	Rd	Orche	1238	Flute2 Med R+	Pi	Orche
1002	Brass Sect1 L- Of	Br	Ensem	1081	Soprano Sax2	Rd	Sax	1160	Oboe2 Med St+	Rd	Orche	1239	Flute2 Med R-	Pi	Orche
1003	Brass Sect1 R Of	Br	Ensem	1082	Soprano Sax2 Of	Rd	Sax	1161	Oboe2 Med St-	Rd	Orche	1240	Flute2 Med St Of	Pi	Orche
1004	Brass Sect1 R+ Of	Br	Ensem	1083	Soprano Sax3	Rd	Sax	1162	Oboe2 Med L	Rd	Orche	1241	Flute2 Med L Of	Pi	Orche
1005	Brass Sect1 R- Of	Br	Ensem	1084	Soprano Sax3+	Rd	Sax	1163	Oboe2 Med L+	Rd	Orche	1242	Flute2 Med R Of	Pi	Orche
1006	Brass Sect Fall	Br	Ensem	1085	Soprano Sax3-	Rd	Sax	1164	Oboe2 Med L-	Rd	Orche	1243	Flute2 Hard St	Pi	Orche
1007	Brass Sect2 Soft St	Br	Ensem	1086	Soprano Sax3 Of	Rd	Sax	1165	Oboe2 Med R	Rd	Orche	1244	Flute2 Hard St+	Pi	Orche
1008	Brass Sect2 Soft St+	Br	Ensem	1087	Alto Sax1	Rd	Sax	1166	Oboe2 Med R+	Rd	Orche	1245	Flute2 Hard St-	Pi	Orche
1009	Brass Sect2 Soft St-	Br	Ensem	1088	Alto Sax1 Of	Rd	Sax	1167	Oboe2 Med R-	Rd	Orche	1246	Flute2 Hard L	Pi	Orche
1010	Brass Sect2 Soft L	Br	Ensem	1089	Alto Sax2	Rd	Sax	1168	Oboe2 Med St Of	Rd	Orche	1247	Flute2 Hard L+	Pi	Orche
1011	Brass Sect2 Soft L+	Br	Ensem	1090	Alto Sax2 Of	Rd	Sax	1169	Oboe2 Med L Of	Rd	Orche	1248	Flute2 Hard L-	Pi	Orche
1012	Brass Sect2 Soft L-	Br	Ensem	1091	Alto Sax Vb	Rd	Sax	1170	Oboe2 Med R Of	Rd	Orche	1249	Flute2 Hard R	Pi	Orche
1013	Brass Sect2 Soft R	Br	Ensem	1092	Alto Sax Vb Of	Rd	Sax	1171	Oboe2 Hard St	Rd	Orche	1250	Flute2 Hard R+	Pi	Orche
1014	Brass Sect2 Soft R+	Br	Ensem	1093	Alto Sax3	Rd	Sax	1172	Oboe2 Hard St+	Rd	Orche	1251	Flute2 Hard R-	Pi	Orche
1015	Brass Sect2 Soft R-	Br	Ensem	1094	Alto Sax3+	Rd	Sax	1173	Oboe2 Hard St-	Rd	Orche	1252	Flute2 Hard St Of	Pi	Orche
1016	Brass Sect2 SoftSIOf	Br	Ensem	1095	Alto Sax3-	Rd	Sax	1174	Oboe2 Hard L	Rd	Orche	1253	Flute2 Hard L Of	Pi	Orche
1017	Brass Sect2 Soft LOf	Br	Ensem	1096	Alto Sax3 Of	Rd	Sax	1175	Oboe2 Hard L+	Rd	Orche	1254	Flute2 Hard R Of	Pi	Orche
1018	Brass Sect2 Soft ROf	Br	Ensem	1097	Tenor Sax1	Rd	Sax	1176	Oboe2 Hard L-	Rd	Orche	1255	Piccolo1	Pi	Orche
1019	Brass Sect2 Med St	Br	Ensem	1098	Tenor Sax1 Of	Rd	Sax	1177	Oboe2 Hard R	Rd	Orche	1256	Piccolo1 Of	Pi	Orche
1020	Brass Sect2 Med St+	Br	Ensem	1099	Tenor Sax2 Soft	Rd	Sax	1178	Oboe2 Hard R+	Rd	Orche	1257	Piccolo2 St	Pi	Orche
1021	Brass Sect2 Med St-	Br	Ensem	1100	Tenor Sax2 Soft+	Rd	Sax	1179	Oboe2 Hard R-	Rd	Orche	1258	Piccolo2 L	Pi	Orche
1022	Brass Sect2 Med L	Br	Ensem	1101	Tenor Sax2 Soft-	Rd	Sax	1180	Oboe2 Hard St Of	Rd	Orche	1259	Piccolo2 R	Pi	Orche
1023	Brass Sect2 Med L+	Br	Ensem	1102	Tenor Sax2 Soft Of	Rd	Sax	1181	Oboe2 Hard L Of	Rd	Orche	1260	Piccolo2 St+	Pi	Orche
1024	Brass Sect2 Med L-	Br	Ensem	1103	Tenor Sax2 Med	Rd	Sax	1182	Oboe2 Hard R Of	Rd	Orche	1261	Piccolo2 L+	Pi	Orche
1025	Brass Sect2 Med R	Br	Ensem	1104	Tenor Sax2 Med+	Rd	Sax	1183	English Horn	Rd	Orche	1262	Piccolo2 R+	Pi	Orche
1026	Brass Sect2 Med R+	Br	Ensem	1105	Tenor Sax2 Med-	Rd	Sax	1184	English Horn Of	Rd	Orche	1263	Piccolo2 St-	Pi	Orche
1027	Brass Sect2 Med R-	Br	Ensem	1106	Tenor Sax2 Med Of	Rd	Sax	1185	Bassoon Med St	Rd	Orche	1264	Piccolo2 L-	Pi	Orche

No.	Name	Main Category	Sub Category	No.	Name	Main Category	Sub Category	No.	Name	Main Category	Sub Category	No.	Name	Main Category	Sub Category
1265	Piccolo2 R-	Pi	Orche	1344	StrongDetuned Pad R	Wv	Pad	1423	Vox G2	Wv	Digi	1502	FM Bass3	Wv	Bass
1266	Piccolo2 St Of	Pi	Orche	1345	Med Detuned 3osc	Wv	Pad	1424	Vox E3	Wv	Digi	1503	FM Bass4	Wv	Bass
1267	Piccolo2 L Of	Pi	Orche	1346	XP Brass	Wv	Pad	1425	DigiOsc1	Wv	Digi	1504	FM Bass5	Wv	Bass
1268	Piccolo2 R Of	Pi	Orche	1347	XP Brass Lp	Wv	Pad	1426	DigiOsc2	Wv	Digi	1505	FM Bass6	Wv	Bass
1269	Breath One Shot	Pi	Orche	1348	String Pad St	Wv	Pad	1427	DigiOsc3	Wv	Digi	1506	Lately-S	Wv	Bass
1270	Pan Flute	Pi	Other	1349	String Pad L	Wv	Pad	1428	DigiOsc4	Wv	Digi	1507	Lately-L	Wv	Bass
1271	Pan Flute-	Pi	Other	1350	String Pad R	Wv	Pad	1429	DigiOsc5	Wv	Digi	1508	Seq Bass	Wv	Bass
1272	Irish Pipe	Pi	Other	1351	OB Brassy Pad St	Wv	Pad	1430	DigiOsc6	Wv	Digi	1509	JP Short Seq St	Wv	Bass
1273	Irish Pipe Of	Pi	Other	1352	OB Brassy Pad L	Wv	Pad	1431	DigiOsc7	Wv	Digi	1510	JP Short Seq L	Wv	Bass
1274	Shakuhachi	Pi	Other	1353	OB Brassy Pad R	Wv	Pad	1432	EP Wave 1	Wv	Digi	1511	JP Short Seq R	Wv	Bass
1275	Shakuhachi Of	Pi	Other	1354	Fat PWM St	Wv	Pad	1433	EP Wave 2	Wv	Digi	1512	Sharp Perc St	Wv	Bass
1276	Recorder	Pi	Other	1355	Fat PWM L	Wv	Pad	1434	EP Wave 3	Wv	Digi	1513	Sharp Perc L	Wv	Bass
1277	Recorder Of	Pi	Other	1356	Fat PWM R	Wv	Pad	1435	EP Wave 4	Wv	Digi	1514	Sharp Perc R	Wv	Bass
1278	Bottle	Pi	Other	1357	Soft Ensemble St	Wv	Pad	1436	EP Wave 5	Wv	Digi	1515	Short Stepper St	Wv	Bass
1279	Ocarina	Pi	Other	1358	Soft Ensemble L	Wv	Pad	1437	EP Wave 6	Wv	Digi	1516	Short Stepper L	Wv	Bass
1280	Ocarina Of	Pi	Other	1359	Soft Ensemble R	Wv	Pad	1438	Organ Wave1	Wv	Digi	1517	Short Stepper R	Wv	Bass
1281	Human Whistle	Pi	Other	1360	Sync Lead1	Wv	Analg	1439	Organ Wave2	Wv	Digi	1518	Mini Blip1	Wv	Other
1282	Didgeridoo 1	Pi	Other	1361	Sync Lead2	Wv	Analg	1440	Organ Wave3	Wv	Digi	1519	Mini Blip2	Wv	Other
1283	Didgeridoo 2	Pi	Other	1362	Sync Lead3	Wv	Analg	1441	DigiBell1	Wv	Digi	1520	Mini Blip3	Wv	Other
1284	Didgeridoo 3	Pi	Other	1363	Sync Lead4	Wv	Analg	1442	DigiBell2	Wv	Digi	1521	Mini Blip4	Wv	Other
1285	Didgeridoo Combi1	Pi	Other	1364	Sync Lead5	Wv	Analg	1443	DigiBell3	Wv	Digi	1522	Mini Blip5	Wv	Other
1286	Didgeridoo Combi2	Pi	Other	1365	Sync LFO	Wv	Analg	1444	DigiBell4	Wv	Digi	1523	Mini Blip6	Wv	Other
1287	Sho	Pi	Other	1366	P5 SawDown 0 dg	Wv	Analg	1445	DigiBell5	Wv	Digi	1524	Noise	Wv	Other
1288	Shanai	Pi	Other	1367	P5 SawDown 180 dg	Wv	Analg	1446	DigiBell6	Wv	Digi	1525	Saturation	Wv	Other
1289	Shanai Of	Pi	Other	1368	P5 SawDown PhasRndm	Wv	Analg	1447	DigiBell7	Wv	Digi	1526	Birch St	Me	Ambie
1290	Ney	Pi	Other	1369	P5 SawUp 0 dg	Wv	Analg	1448	Spectrum1	Wv	Digi	1527	Birch L	Me	Ambie
1291	Ney Of	Pi	Other	1370	P5 SawUp 90 dg	Wv	Analg	1449	Spectrum2	Wv	Digi	1528	Birch R	Me	Ambie
1292	Kaval	Pi	Other	1371	P5 SawUp 180 dg	Wv	Analg	1450	Spectrum3	Wv	Digi	1529	Willow St	Me	Ambie
1293	Kaval Of	Pi	Other	1372	P5 SawUp 270 dg	Wv	Analg	1451	3o3 Saw	Wv	Bass	1530	Willow L	Me	Ambie
1294	Hah Choir St	Vo	Voice	1373	OB Saw	Wv	Analg	1452	3o3 Saw2	Wv	Bass	1531	Willow R	Me	Ambie
1295	Hah Choir L	Vo	Voice	1374	Saw	Wv	Analg	1453	3o3 Square	Wv	Bass	1532	Anemone St	Me	Ambie
1296	Hah Choir R	Vo	Voice	1375	1o1 Saw	Wv	Analg	1454	Mini Bass1	Wv	Bass	1533	Anemone L	Me	Ambie
1297	Ooh Choir St	Vo	Voice	1376	1o1 Sub	Wv	Analg	1455	Mini Bass1 Of	Wv	Bass	1534	Anemone R	Me	Ambie
1298	Ooh Choir L	Vo	Voice	1377	Saw Square	Wv	Analg	1456	Mini Bass2	Wv	Bass	1535	Magnitude St	Me	Ambie
1299	Ooh Choir R	Vo	Voice	1378	Square Saw	Wv	Analg	1457	Mini Bass2 Of	Wv	Bass	1536	Magnitude L	Me	Ambie
1300	Ooh St	Vo	Voice	1379	Mg Ramp	Wv	Analg	1458	Mini Bass3a	Wv	Bass	1537	Magnitude R	Me	Ambie
1301	Ooh L	Vo	Voice	1380	P10-1	Wv	Analg	1459	Mini Bass3b	Wv	Bass	1538	SabreTone	Me	Ambie
1302	Ooh R	Vo	Voice	1381	P10-2	Wv	Analg	1460	Mini Bass3c	Wv	Bass	1539	Vox Bell	Me	Ambie
1303	Ooh St Of	Vo	Voice	1382	P10-3	Wv	Analg	1461	Q Synbass	Wv	Bass	1540	Mellow	Me	Ambie
1304	Ooh L Of	Vo	Voice	1383	P25-1	Wv	Analg	1462	Q Synbass Of	Wv	Bass	1541	BellAir	Me	Ambie
1305	Ooh R Of	Vo	Voice	1384	P25-2	Wv	Analg	1463	Punch	Wv	Bass	1542	BigSyn	Me	Ambie
1306	Cho Breath L	Vo	Voice	1385	P50-1	Wv	Analg	1464	Punch Of	Wv	Bass	1543	Trance Choir	Me	Ambie
1307	Cho Breath R	Vo	Voice	1386	P50-2	Wv	Analg	1465	Synth Bass 1	Wv	Bass	1544	Eery	Me	Ambie
1308	SynVox	Vo	Voice	1387	Tri Wave	Wv	Analg	1466	Synth Bass2	Wv	Bass	1545	VoxAlk	Me	Ambie
1309	VoxNoiz	Vo	Voice	1388	Sine	Wv	Analg	1467	Blip Bass	Wv	Bass	1546	Hi-Lo	Me	Ambie
1310	Itopia	Vo	Voice	1389	Heterodyning	Wv	Analg	1468	Blip Bass Of	Wv	Bass	1547	AirHose St	Me	Ambie
1311	Granu Vox	Vo	Voice	1390	Ring Mod	Wv	Digi	1469	Klick Bass	Wv	Bass	1548	AirHose L	Me	Ambie
1312	Day	Vo	Voice	1391	FM Square	Wv	Digi	1470	Klick Bass Of	Wv	Bass	1549	AirHose R	Me	Ambie
1313	So Long	Vo	Voice	1392	FM Shaper	Wv	Digi	1471	Puls Bass	Wv	Bass	1550	Space Scream	Me	Ambie
1314	Vocal Osc	Vo	Voice	1393	FM Metal1	Wv	Digi	1472	Puls Bass Of	Wv	Bass	1551	Ooh Feedback	Me	Ambie
1315	PWM Strings St	Wv	Pad	1394	FM Metal2	Wv	Digi	1473	Dirty Perc	Wv	Bass	1552	Fairwave	Me	Ambie
1316	PWM Strings Mn	Wv	Pad	1395	FM Organ1	Wv	Digi	1474	Short Uni	Wv	Bass	1553	Mini Bell	Me	Ambie
1317	Long Saw	Wv	Pad	1396	FM Organ2	Wv	Digi	1475	Short Uni Of	Wv	Bass	1554	Sonar1	Me	Ambie
1318	Fat Saw St	Wv	Pad	1397	FM Organ3	Wv	Digi	1476	Noise Bass	Wv	Bass	1555	Sonar2	Me	Ambie
1319	Fat Saw Mn	Wv	Pad	1398	FM Organ4	Wv	Digi	1477	Noise Bass Of	Wv	Bass	1556	Digi Breath	Me	Ambie
1320	Fat Saw Mn-	Wv	Pad	1399	FM Tubular Bass	Wv	Digi	1478	Mg Bass1	Wv	Bass	1557	Engine Room St	Me	Ambie
1321	OB Mod Saw	Wv	Pad	1400	FM Funk	Wv	Digi	1479	Mg Bass1 Of	Wv	Bass	1558	Engine Room L	Me	Ambie
1322	VP Strings St	Wv	Pad	1401	FM Guitar	Wv	Digi	1480	Mg Bass2	Wv	Bass	1559	Engine Room R	Me	Ambie
1323	VP Strings L	Wv	Pad	1402	FS Buzz	Wv	Digi	1481	Mg Bass2 Of	Wv	Bass	1560	Moving Chime St	Me	Ambie
1324	VP Strings R	Wv	Pad	1403	Wet Pluck	Wv	Digi	1482	Mg Bass3	Wv	Bass	1561	Moving Chime L	Me	Ambie
1325	OB Strings	Wv	Pad	1404	Digi 01	Wv	Digi	1483	Mg Bass3 Of	Wv	Bass	1562	Moving Chime R	Me	Ambie
1326	Syzle Strings	Wv	Pad	1405	Digi 02	Wv	Digi	1484	Mod Bass	Wv	Bass	1563	Motion Beam	Me	Ambie
1327	Padd	Wv	Pad	1406	Digi 03	Wv	Digi	1485	Analog Bass1	Wv	Bass	1564	Bell Spectrum St	Me	Ambie
1328	Dark Light	Wv	Pad	1407	Digi 04	Wv	Digi	1486	Analog Bass1 Of	Wv	Bass	1565	Bell Spectrum L	Me	Ambie
1329	OB Brass	Wv	Pad	1408	Digi 05	Wv	Digi	1487	Analog Bass2	Wv	Bass	1566	Bell Spectrum R	Me	Ambie
1330	Trance St	Wv	Pad	1409	Digi 06	Wv	Digi	1488	Analog Bass2 Of	Wv	Bass	1567	Hybrid Pad St	Me	Ambie
1331	Trance Mn	Wv	Pad	1410	Digi 07	Wv	Digi	1489	Analog Bass3	Wv	Bass	1568	Hybrid Pad L	Me	Ambie
1332	PWM Fast	Wv	Pad	1411	Digi 08	Wv	Digi	1490	Analog Bass4	Wv	Bass	1569	Hybrid Pad R	Me	Ambie
1333	PWM Slow	Wv	Pad	1412	Digi 09	Wv	Digi	1491	Analog Bass4 Of	Wv	Bass	1570	Wavedance St	Me	Ambie
1334	CS80 Brass	Wv	Pad	1413	Digi 10	Wv	Digi	1492	Analog Bass5	Wv	Bass	1571	Wavedance L	Me	Ambie
1335	Airy Sine	Wv	Pad	1414	Digi 11	Wv	Digi	1493	Analog Bass5 Of	Wv	Bass	1572	Wavedance R	Me	Ambie
1336	String Machine	Wv	Pad	1415	Digi 12	Wv	Digi	1494	Analog Bass6	Wv	Bass	1573	Leftpitch St	Me	Ambie
1337	String Machine+	Wv	Pad	1416	Bell1 Wave	Wv	Digi	1495	Analog Bass6 Of	Wv	Bass	1574	Leftpitch L	Me	Ambie
1338	String Machine-	Wv	Pad	1417	Bell2 Wave	Wv	Digi	1496	UniBass	Wv	Bass	1575	Leftpitch R	Me	Ambie
1339	Med Detuned Pad St	Wv	Pad	1418	DigiVox1	Wv	Digi	1497	UniBass Of	Wv	Bass	1576	Pitchomat St	Me	Ambie
1340	Med Detuned Pad L	Wv	Pad	1419	DigiVox2	Wv	Digi	1498	T8 Kick Bass	Wv	Bass	1577	Pitchomat L	Me	Ambie
1341	Med Detuned Pad R	Wv	Pad	1420	DigiVox3	Wv	Digi	1499	T8 Kick Bass Of	Wv	Bass	1578	Pitchomat R	Me	Ambie
1342	StrongDetuned Pad St	Wv	Pad	1421	DigiVox4	Wv	Digi	1500	FM Bass1	Wv	Bass	1579	Reflecting St	Me	Ambie
1343	StrongDetuned Pad L	Wv	Pad	1422	DigiVox5	Wv	Digi	1501	FM Bass2	Wv	Bass	1580	Reflecting L	Me	Ambie

No.	Name	Main Category	Sub Category	No.	Name	Main Category	Sub Category	No.	Name	Main Category	Sub Category	No.	Name	Main Category	Sub Category
1581	Reflecting R	Me	Ambie	1660	LFO Seq	Me	Other	1739	Helicopter	Se	SE	1818	AcousticGtr FX16 R	Se	MgFX
1582	Spectrals St	Me	Ambie	1661	Raspberry	Me	Other	1740	Seashore	Se	SE	1819	AcousticGtr FX17 St	Se	MgFX
1583	Spectrals L	Me	Ambie	1662	DigitHell	Me	Other	1741	Telephone	Se	SE	1820	AcousticGtr FX17 L	Se	MgFX
1584	Spectrals R	Me	Ambie	1663	Computer St	Me	Other	1742	TelRIng	Se	SE	1821	AcousticGtr FX17 R	Se	MgFX
1585	The Fog St	Me	Ambie	1664	Computer L	Me	Other	1743	Bird	Se	SE	1822	AcousticGtr FX18 St	Se	MgFX
1586	The Fog L	Me	Ambie	1665	Computer R	Me	Other	1744	Stream	Se	SE	1823	AcousticGtr FX18 L	Se	MgFX
1587	The Fog R	Me	Ambie	1666	Chatter	Me	Other	1745	Gunshot	Se	SE	1824	AcousticGtr FX18 R	Se	MgFX
1588	Orchestra Hit1 St	Me	Hit	1667	Fx Cymbals St	Me	Other	1746	Applause	Se	SE	1825	AcousticGtr FX19 St	Se	MgFX
1589	Orchestra Hit1 L	Me	Hit	1668	Fx Cymbals L	Me	Other	1747	RainLoop	Se	SE	1826	AcousticGtr FX19 L	Se	MgFX
1590	Orchestra Hit1 R	Me	Hit	1669	Fx Cymbals R	Me	Other	1748	Scratch H	Se	Scrtc	1827	AcousticGtr FX19 R	Se	MgFX
1591	Orchestra Hit2 St	Me	Hit	1670	Warning Mod	Me	Other	1749	Scratch L	Se	Scrtc	1828	AcousticGtr FX20 St	Se	MgFX
1592	Orchestra Hit2 L	Me	Hit	1671	VocalRes	Me	Other	1750	Scratch Down	Se	Scrtc	1829	AcousticGtr FX20 L	Se	MgFX
1593	Orchestra Hit2 R	Me	Hit	1672	Hoo	Me	Other	1751	Scratch Hi F	Se	Scrtc	1830	AcousticGtr FX20 R	Se	MgFX
1594	Orchestra Hit3	Me	Hit	1673	Bell Choir	Me	Other	1752	Scratch Hi R	Se	Scrtc	1831	AcousticGtr FX21 St	Se	MgFX
1595	SlabOrgan1	Me	Hit	1674	Bell Choir Lp	Me	Other	1753	Scratch Lo F	Se	Scrtc	1832	AcousticGtr FX21 L	Se	MgFX
1596	HH Hit	Me	Hit	1675	VibeNP	Me	Other	1754	Scratch Lo R	Se	Scrtc	1833	AcousticGtr FX21 R	Se	MgFX
1597	Hit Orchestra1	Me	Hit	1676	Shower St	Se	SE	1755	Scratch Bd F	Se	Scrtc	1834	AcousticGtr FX22 St	Se	MgFX
1598	Hit Brass	Me	Hit	1677	Shower L	Se	SE	1756	Scratch Bd R	Se	Scrtc	1835	AcousticGtr FX22 L	Se	MgFX
1599	Slab Orchestra	Me	Hit	1678	Shower R	Se	SE	1757	Scratch Sd F	Se	Scrtc	1836	AcousticGtr FX22 R	Se	MgFX
1600	Slab Giant	Me	Hit	1679	Fx Female Voice St	Se	SE	1758	Scratch Sd R	Se	Scrtc	1837	AcousticGtr FX23 St	Se	MgFX
1601	Slab Hard	Me	Hit	1680	Fx Female Voice L	Se	SE	1759	Scratch Vo F	Se	Scrtc	1838	AcousticGtr FX23 L	Se	MgFX
1602	Slab Organ2	Me	Hit	1681	Fx Female Voice R	Se	SE	1760	Scratch Vo R	Se	Scrtc	1839	AcousticGtr FX23 R	Se	MgFX
1603	Slab Ash	Me	Hit	1682	Grain1	Se	SE	1761	Scratch Stop	Se	Scrtc	1840	AcousticGtr FX24 St	Se	MgFX
1604	Hit Uhh	Me	Hit	1683	Grain2 St	Se	SE	1762	Scratch Spin	Se	Scrtc	1841	AcousticGtr FX24 L	Se	MgFX
1605	Hit Orchestra2	Me	Hit	1684	Grain2 L	Se	SE	1763	Scratch Hip	Se	Scrtc	1842	AcousticGtr FX24 R	Se	MgFX
1606	Vox Drum	Me	Hit	1685	Grain2 R	Se	SE	1764	Scratch Hip2	Se	Scrtc	1843	AcousticGtr FX25 St	Se	MgFX
1607	FX Chime	Me	EFX	1686	Grain3 St	Se	SE	1765	Scratch Attack	Se	Scrtc	1844	AcousticGtr FX25 L	Se	MgFX
1608	Bubble	Me	EFX	1687	Grain3 L	Se	SE	1766	Scratch R&B	Se	Scrtc	1845	AcousticGtr FX25 R	Se	MgFX
1609	Lektronica	Me	EFX	1688	Grain3 R	Se	SE	1767	Scratch Combi	Se	Scrtc	1846	AcousticGtr FX26 St	Se	MgFX
1610	Loop145	Me	EFX	1689	Moving Harp St	Se	SE	1768	Scratch Combi2	Se	Scrtc	1847	AcousticGtr FX26 L	Se	MgFX
1611	X-Fade	Me	EFX	1690	Moving Harp L	Se	SE	1769	Scratch Combi3	Se	Scrtc	1848	AcousticGtr FX26 R	Se	MgFX
1612	Resonance X-Fade	Me	EFX	1691	Moving Harp R	Se	SE	1770	Scratch Combi4	Se	Scrtc	1849	AcousticGtr FX27 St	Se	MgFX
1613	Quiet	Me	EFX	1692	Metal Mod	Se	SE	1771	AcousticGtr FX01 St	Se	MgFX	1850	AcousticGtr FX27 L	Se	MgFX
1614	Hop FX1	Me	EFX	1693	Digital Wind	Se	SE	1772	AcousticGtr FX01 L	Se	MgFX	1851	AcousticGtr FX27 R	Se	MgFX
1615	Hop FX2	Me	EFX	1694	Digi Voice Mod	Se	SE	1773	AcousticGtr FX01 R	Se	MgFX	1852	AcousticGtr FX28 St	Se	MgFX
1616	Neo Seq Em All	Me	EFX	1695	Ethnic Rhythm Rv All	Se	SE	1774	AcousticGtr FX02 St	Se	MgFX	1853	AcousticGtr FX28 L	Se	MgFX
1617	Neo Seq Em-1	Me	EFX	1696	Ethnic Rhythm Rv-1	Se	SE	1775	AcousticGtr FX02 L	Se	MgFX	1854	AcousticGtr FX28 R	Se	MgFX
1618	Neo Seq Em-2	Me	EFX	1697	Ethnic Rhythm Rv-2	Se	SE	1776	AcousticGtr FX02 R	Se	MgFX	1855	AcousticGtr FX29 St	Se	MgFX
1619	Neo Seq Em-3	Me	EFX	1698	Ethnic Rhythm Rv-3	Se	SE	1777	AcousticGtr FX03 St	Se	MgFX	1856	AcousticGtr FX29 L	Se	MgFX
1620	Neo Seq Em-4	Me	EFX	1699	Ethnic Rhythm Rv-4	Se	SE	1778	AcousticGtr FX03 L	Se	MgFX	1857	AcousticGtr FX29 R	Se	MgFX
1621	Neo Seq Em-5	Me	EFX	1700	Ethnic Rhythm Rv-5	Se	SE	1779	AcousticGtr FX03 R	Se	MgFX	1858	AcousticGtr FX30 St	Se	MgFX
1622	Neo Seq Em-6	Me	EFX	1701	Ethnic Rhythm Rv-6	Se	SE	1780	AcousticGtr FX04 St	Se	MgFX	1859	AcousticGtr FX30 L	Se	MgFX
1623	Neo Seq Em-7	Me	EFX	1702	Ethnic Rhythm Rv-7	Se	SE	1781	AcousticGtr FX04 L	Se	MgFX	1860	AcousticGtr FX30 R	Se	MgFX
1624	Neo Seq Em-8	Me	EFX	1703	Ripper	Se	SE	1782	AcousticGtr FX04 R	Se	MgFX	1861	ElectricGtr FX01	Se	MgFX
1625	Whisper Seq Bb	Me	EFX	1704	Glass	Se	SE	1783	AcousticGtr FX05 St	Se	MgFX	1862	ElectricGtr FX02	Se	MgFX
1626	Whisper Seq Bb Of	Me	EFX	1705	Bell FX1	Se	SE	1784	AcousticGtr FX05 L	Se	MgFX	1863	ElectricGtr FX03	Se	MgFX
1627	Woody Seq St	Me	EFX	1706	Bell FX2	Se	SE	1785	AcousticGtr FX05 R	Se	MgFX	1864	ElectricGtr FX04	Se	MgFX
1628	Woody Seq L	Me	EFX	1707	IndusTom	Se	SE	1786	AcousticGtr FX06 St	Se	MgFX	1865	ElectricGtr FX05	Se	MgFX
1629	Woody Seq R	Me	EFX	1708	Noise Burst	Se	SE	1787	AcousticGtr FX06 L	Se	MgFX	1866	ElectricGtr FX06	Se	MgFX
1630	Neo Seq2 Em All	Me	EFX	1709	Zap1	Se	SE	1788	AcousticGtr FX06 R	Se	MgFX	1867	ElectricGtr FX07	Se	MgFX
1631	Neo Seq2 Em-1	Me	EFX	1710	Zap2	Se	SE	1789	AcousticGtr FX07 St	Se	MgFX	1868	ElectricGtr FX08	Se	MgFX
1632	Neo Seq2 Em-2	Me	EFX	1711	Electric Perc1	Se	SE	1790	AcousticGtr FX07 L	Se	MgFX	1869	ElectricGtr FX09	Se	MgFX
1633	Neo Seq2 Em-3	Me	EFX	1712	Electric Perc2	Se	SE	1791	AcousticGtr FX07 R	Se	MgFX	1870	ElectricGtr FX10	Se	MgFX
1634	Neo Seq2 Em-4	Me	EFX	1713	Electric Perc3	Se	SE	1792	AcousticGtr FX08 St	Se	MgFX	1871	ElectricGtr FX11	Se	MgFX
1635	Neo Seq2 Em-5	Me	EFX	1714	Electric Perc4	Se	SE	1793	AcousticGtr FX08 L	Se	MgFX	1872	ElectricGtr FX12	Se	MgFX
1636	Neo Seq2 Em-6	Me	EFX	1715	Electric Perc5	Se	SE	1794	AcousticGtr FX08 R	Se	MgFX	1873	ElectricGtr FX13	Se	MgFX
1637	Neo Seq2 Em-7	Me	EFX	1716	Electric Perc6	Se	SE	1795	AcousticGtr FX09 St	Se	MgFX	1874	ElectricGtr FX14	Se	MgFX
1638	Neo Seq2 Em-8	Me	EFX	1717	Electric Perc7	Se	SE	1796	AcousticGtr FX09 L	Se	MgFX	1875	ElectricGtr FX15	Se	MgFX
1639	Portamento Lead Seq	Me	EFX	1718	Electric Perc8	Se	SE	1797	AcousticGtr FX09 R	Se	MgFX	1876	ElectricGtr FX16	Se	MgFX
1640	Aero Seq All	Me	EFX	1719	Electric Perc9	Se	SE	1798	AcousticGtr FX10 St	Se	MgFX	1877	ElectricGtr FX17	Se	MgFX
1641	Aero Seq-1	Me	EFX	1720	Electric Perc10	Se	SE	1799	AcousticGtr FX10 L	Se	MgFX	1878	ElectricGtr FX18	Se	MgFX
1642	Aero Seq-2	Me	EFX	1721	Electric Perc11	Se	SE	1800	AcousticGtr FX10 R	Se	MgFX	1879	ElectricGtr FX19	Se	MgFX
1643	Aero Seq-3	Me	EFX	1722	Electric Perc12	Se	SE	1801	AcousticGtr FX11 St	Se	MgFX	1880	ElectricGtr FX20	Se	MgFX
1644	Aero Seq-4	Me	EFX	1723	Electric Perc13	Se	SE	1802	AcousticGtr FX11 L	Se	MgFX	1881	ElectricGtr FX21	Se	MgFX
1645	Aero Seq-5	Me	EFX	1724	Electric Perc14	Se	SE	1803	AcousticGtr FX11 R	Se	MgFX	1882	ElectricGtr FX22	Se	MgFX
1646	Aero Seq-6	Me	EFX	1725	Electric Perc15	Se	SE	1804	AcousticGtr FX12 St	Se	MgFX	1883	ElectricGtr FX23	Se	MgFX
1647	Aero Seq-7	Me	EFX	1726	Hi Q1	Se	SE	1805	AcousticGtr FX12 L	Se	MgFX	1884	Acoustic Bass FX01	Se	MgFX
1648	Aero Seq-8	Me	EFX	1727	Hi Q2	Se	SE	1806	AcousticGtr FX12 R	Se	MgFX	1885	Acoustic Bass FX02	Se	MgFX
1649	Aero Seq-9	Me	EFX	1728	Vox Hit Rev	Se	SE	1807	AcousticGtr FX13 St	Se	MgFX	1886	Acoustic Bass FX03	Se	MgFX
1650	Aero Seq-10	Me	EFX	1729	Bomb	Se	SE	1808	AcousticGtr FX13 L	Se	MgFX	1887	Acoustic Bass FX04	Se	MgFX
1651	Aero Seq-11	Me	EFX	1730	Tape Rewind	Se	SE	1809	AcousticGtr FX13 R	Se	MgFX	1888	Acoustic Bass FX05	Se	MgFX
1652	Aero Seq-12	Me	EFX	1731	FxGun1	Se	SE	1810	AcousticGtr FX14 St	Se	MgFX	1889	Acoustic Bass FX06	Se	MgFX
1653	Aero Seq-13	Me	EFX	1732	FxGun2	Se	SE	1811	AcousticGtr FX14 L	Se	MgFX	1890	Acoustic Bass FX07	Se	MgFX
1654	Aero Seq-14	Me	EFX	1733	Thunder	Se	SE	1812	AcousticGtr FX14 R	Se	MgFX	1891	Acoustic Bass FX08	Se	MgFX
1655	Aero Seq-15	Me	EFX	1734	Swarm	Se	SE	1813	AcousticGtr FX15 St	Se	MgFX	1892	Acoustic Bass FX09	Se	MgFX
1656	Aero Seq-16	Me	EFX	1735	TurnTable	Se	SE	1814	AcousticGtr FX15 L	Se	MgFX	1893	Electric Bass FX 01	Se	MgFX
1657	Electer	Me	Other	1736	Police	Se	SE	1815	AcousticGtr FX15 R	Se	MgFX	1894	Electric Bass FX 02	Se	MgFX
1658	MultiPiano	Me	Other	1737	Door Squeak	Se	SE	1816	AcousticGtr FX16 St	Se	MgFX	1895	Electric Bass FX 03	Se	MgFX
1659	Radio Noise	Me	Other	1738	Heart Beat	Se	SE	1817	AcousticGtr FX16 L	Se	MgFX	1896	Electric Bass FX 04	Se	MgFX

No.	Name	Main Category	Sub Category	No.	Name	Main Category	Sub Category	No.	Name	Main Category	Sub Category	No.	Name	Main Category	Sub Category
1897	Electric Bass FX 05	Se	MgFX	1976	Conga1 Hi SlapMute 2	Pc	Latin	2055	Ganza Forward	Pc	Latin	2134	Djembe1 Combi	Pc	Ethnc
1898	Electric Bass FX 06	Se	MgFX	1977	Conga1 Lo Tip	Pc	Latin	2056	Maracas Sw	Pc	Latin	2135	Djembe2 Lo	Pc	Ethnc
1899	Electric Bass FX 07	Se	MgFX	1978	Conga1 Lo Heel	Pc	Latin	2057	Maracas Stur	Pc	Latin	2136	Djembe2 Slap	Pc	Ethnc
1900	Electric Bass FX 08	Se	MgFX	1979	Conga1 Lo Open 1-2	Pc	Latin	2058	Maracas Staccato	Pc	Latin	2137	Djembe2 Mute	Pc	Ethnc
1901	Electric Bass FX 09	Se	MgFX	1980	Conga1 Lo Open 1	Pc	Latin	2059	CabasaA 1-2	Pc	Latin	2138	Djembe3 Lo	Pc	Ethnc
1902	Electric Bass FX 10	Se	MgFX	1981	Conga1 Lo Open 2	Pc	Latin	2060	CabasaA 1	Pc	Latin	2139	Djembe3 Slap	Pc	Ethnc
1903	Electric Bass FX 11	Se	MgFX	1982	Conga1 Lo Mute	Pc	Latin	2061	CabasaA 2	Pc	Latin	2140	Djembe3 Mute	Pc	Ethnc
1904	Electric Bass FX 12	Se	MgFX	1983	Conga1 Lo Slap Open	Pc	Latin	2062	CabasaB 1-4	Pc	Latin	2141	Tabla Bya	Pc	Ethnc
1905	Electric Bass FX 13	Se	MgFX	1984	Conga2 Hi Heel	Pc	Latin	2063	CabasaB 1	Pc	Latin	2142	Tabla Nah	Pc	Ethnc
1906	Electric Bass FX 14	Se	MgFX	1985	Conga2 Hi Tip	Pc	Latin	2064	CabasaB 2	Pc	Latin	2143	Tabla Mute	Pc	Ethnc
1907	Electric Bass FX 15	Se	MgFX	1986	Conga2 Hi Slap 1-2	Pc	Latin	2065	CabasaB 3	Pc	Latin	2144	Tabla Combi	Pc	Ethnc
1908	Electric Bass FX 16	Se	MgFX	1987	Conga2 Hi Slap 1	Pc	Latin	2066	CabasaB 4	Pc	Latin	2145	Dohol Low	Pc	Ethnc
1909	Electric Bass FX 17	Se	MgFX	1988	Conga2 Hi Slap 2	Pc	Latin	2067	Caxixi 1-2	Pc	Latin	2146	Dohol High	Pc	Ethnc
1910	Electric Bass FX 18	Se	MgFX	1989	Conga2 Hi Open 1-2	Pc	Latin	2068	Caxixi 1	Pc	Latin	2147	Lama Cymbal	Pc	Ethnc
1911	Electric Bass FX 19	Se	MgFX	1990	Conga2 Hi Open 1	Pc	Latin	2069	Caxixi 2	Pc	Latin	2148	Mondira	Pc	Ethnc
1912	Electric Bass FX 20	Se	MgFX	1991	Conga2 Hi Open 2	Pc	Latin	2070	Tumbo 1	Pc	Latin	2149	Tibetan Bell	Pc	Ethnc
1913	Electric Bass FX 21	Se	MgFX	1992	Conga2 Hi Mute	Pc	Latin	2071	Tumbo 2	Pc	Latin	2150	Tibetan Bowl	Pc	Ethnc
1914	Electric Bass FX 22	Se	MgFX	1993	Conga2 Lo Open 1-2	Pc	Latin	2072	Tumbo 3	Pc	Latin	2151	Shekere Shake Sw	Pc	Ethnc
1915	Electric Bass FX 23	Se	MgFX	1994	Conga2 Lo Open 1	Pc	Latin	2073	Pandeiro Open	Pc	Latin	2152	Shekere Down	Pc	Ethnc
1916	ShakerA 1/3	Pc	Pop	1995	Conga2 Lo Open 2	Pc	Latin	2074	Pandeiro Thump	Pc	Latin	2153	Shekere Up	Pc	Ethnc
1917	ShakerA 1	Pc	Pop	1996	Conga2 Lo Slide	Pc	Latin	2075	Pandeiro Tip	Pc	Latin	2154	Shekere Slap	Pc	Ethnc
1918	ShakerA 2	Pc	Pop	1997	Quinto1 Open	Pc	Latin	2076	Pandeiro Heel	Pc	Latin	2155	TalkingDrum Open	Pc	Ethnc
1919	ShakerA 3	Pc	Pop	1998	Quinto1 Slap	Pc	Latin	2077	Tmbourim Open	Pc	Latin	2156	TalkingDrum Slap	Pc	Ethnc
1920	ShakerB Sw	Pc	Pop	1999	Quinto2 Open	Pc	Latin	2078	Tmbourim Finger	Pc	Latin	2157	TalkingDrum Mute	Pc	Ethnc
1921	ShakerB Shake	Pc	Pop	2000	Quinto2 Heel	Pc	Latin	2079	Tmbourim Mute	Pc	Latin	2158	TalkingDrum Bend 1-4	Pc	Ethnc
1922	ShakerB Hit	Pc	Pop	2001	Tumba Open	Pc	Latin	2080	Agogo Hi	Pc	Latin	2159	TalkingDrum Bend 1	Pc	Ethnc
1923	Shaker Hip1	Pc	Pop	2002	Tumba Slap	Pc	Latin	2081	Agogo Lo	Pc	Latin	2160	TalkingDrum Bend 2	Pc	Ethnc
1924	Shaker Hip2	Pc	Pop	2003	Tumba Tip	Pc	Latin	2082	Agogo Lo Tap	Pc	Latin	2161	TalkingDrum Bend 3	Pc	Ethnc
1925	Shaker Hip3	Pc	Pop	2004	Tumba Heel	Pc	Latin	2083	Guiro Long	Pc	Latin	2162	TalkingDrum Bend 4	Pc	Ethnc
1926	Shaker Hip4	Pc	Pop	2005	Cuica Lo	Pc	Latin	2084	Guiro Short	Pc	Latin	2163	Kenkeni Sw	Pc	Ethnc
1927	Tambourine1 Sw	Pc	Pop	2006	Cuica Hi	Pc	Latin	2085	Guiro Swp	Pc	Latin	2164	Kenkeni Close	Pc	Ethnc
1928	Tambourine1 Shake	Pc	Pop	2007	Bongo1 Hi 1Finger 1-2	Pc	Latin	2086	MetalGuiro Short 1-2	Pc	Latin	2165	Kenkeni Open	Pc	Ethnc
1929	Tambourine1 Hit	Pc	Pop	2008	Bongo1 Hi 1Finger 1	Pc	Latin	2087	MetalGuiro Short 1	Pc	Latin	2166	Sangban Sw	Pc	Ethnc
1930	Tambourine2 Sw	Pc	Pop	2009	Bongo1 Hi 1Finger 2	Pc	Latin	2088	MetalGuiro Short 2	Pc	Latin	2167	Sangban Close	Pc	Ethnc
1931	Tambourine2 Shake	Pc	Pop	2010	Bongo1 Hi 3Finger 1-2	Pc	Latin	2089	MetalGuiro Long	Pc	Latin	2168	Sangban Open	Pc	Ethnc
1932	Tambourine2 Hit	Pc	Pop	2011	Bongo1 Hi 3Finger 1	Pc	Latin	2090	Surdo1 Open	Pc	Latin	2169	Dundun Bell Sw	Pc	Ethnc
1933	Slick1	Pc	Pop	2012	Bongo1 Hi 3Finger 2	Pc	Latin	2091	Surdo1 Mute	Pc	Latin	2170	Dundun Bell Close	Pc	Ethnc
1934	Slick2	Pc	Pop	2013	Bongo1 Hi Rim	Pc	Latin	2092	Surdo2 Open	Pc	Latin	2171	Dundun Bell Open	Pc	Ethnc
1935	Castanet1	Pc	Pop	2014	Bongo1 Hi Tip	Pc	Latin	2093	Surdo2 Mute	Pc	Latin	2172	Ainote 1	Pc	Ethnc
1936	Castanet2 Sw	Pc	Pop	2015	Bongo1 Hi Heel	Pc	Latin	2094	Cajon1 Kick	Pc	Latin	2173	Ainote 2	Pc	Ethnc
1937	Castanet2 Soft	Pc	Pop	2016	Bongo1 Hi Slap	Pc	Latin	2095	Cajon1 Slap	Pc	Latin	2174	Chanchiki Chan	Pc	Ethnc
1938	Castanet2 Hard	Pc	Pop	2017	Bongo1 Lo 1Finger 1-2	Pc	Latin	2096	Cajon1 Tip 1-2	Pc	Latin	2175	Chanchiki Ki	Pc	Ethnc
1939	Wood Block	Pc	Pop	2018	Bongo1 Lo 1Finger 1	Pc	Latin	2097	Cajon1 Tip 1	Pc	Latin	2176	Atarigane Con	Pc	Ethnc
1940	Vibraslap1	Pc	Pop	2019	Bongo1 Lo 1Finger 2	Pc	Latin	2098	Cajon1 Tip 2	Pc	Latin	2177	Atarigane Chi	Pc	Ethnc
1941	Vibraslap2	Pc	Pop	2020	Bongo1 Lo 3Finger 1-2	Pc	Latin	2099	Cajon2 Foot	Pc	Latin	2178	Wa Taiko	Pc	Ethnc
1942	Triangle Sw	Pc	Pop	2021	Bongo1 Lo 3Finger 1	Pc	Latin	2100	Cajon2 Lo	Pc	Latin	2179	Oo Taiko1 Don	Pc	Ethnc
1943	Triangle Open	Pc	Pop	2022	Bongo1 Lo 3Finger 2	Pc	Latin	2101	Cajon2 Slap	Pc	Latin	2180	Oo Taiko1 Ka	Pc	Ethnc
1944	Triangle Mute	Pc	Pop	2023	Bongo1 Lo Rim	Pc	Latin	2102	Cajon2 Mute	Pc	Latin	2181	Oo Taiko2 Don Soft	Pc	Ethnc
1945	Hand Clap1 St	Pc	Pop	2024	Bongo1 Lo Tip	Pc	Latin	2103	Cajon2 Tip	Pc	Latin	2182	Oo Taiko2 Don Hard	Pc	Ethnc
1946	Hand Clap1 L	Pc	Pop	2025	Bongo2 Hi Mute	Pc	Latin	2104	Cajon2 Ghost1	Pc	Latin	2183	Oo Taiko2 Zu	Pc	Ethnc
1947	Hand Clap1 R	Pc	Pop	2026	Bongo2 Hi Open 1-2	Pc	Latin	2105	Cajon2 Ghost2	Pc	Latin	2184	Oo Taiko2 Ka	Pc	Ethnc
1948	Hand Clap2 Sw	Pc	Pop	2027	Bongo2 Hi Open 1	Pc	Latin	2106	Claves1	Pc	Latin	2185	Yagura Taiko1 Don	Pc	Ethnc
1949	Hand Clap2 Close	Pc	Pop	2028	Bongo2 Hi Open 2	Pc	Latin	2107	Claves2	Pc	Latin	2186	Yagura Taiko1 Zu	Pc	Ethnc
1950	Hand Clap2 Open	Pc	Pop	2029	Bongo2 Lo Mute	Pc	Latin	2108	Whistle	Pc	Latin	2187	Yagura Taiko1 Ka	Pc	Ethnc
1951	Finger Snap	Pc	Pop	2030	Bongo2 Lo Open 1-2	Pc	Latin	2109	Cowbell1	Pc	Latin	2188	Yagura Taiko2 Don	Pc	Ethnc
1952	Handbell L	Pc	Pop	2031	Bongo2 Lo Open 1	Pc	Latin	2110	Cowbell2	Pc	Latin	2189	Yagura Taiko2 Zu	Pc	Ethnc
1953	Handbell H	Pc	Pop	2032	Bongo2 Lo Open 2	Pc	Latin	2111	Cowbell3 Sw	Pc	Latin	2190	Yagura Taiko2 Ka	Pc	Ethnc
1954	Sleigh Bell1	Pc	Pop	2033	Timbale1 Hi 1-3	Pc	Latin	2112	Cowbell3 Mute	Pc	Latin	2191	Shime Taiko1 Ten	Pc	Ethnc
1955	Sleigh Bell2	Pc	Pop	2034	Timbale1 Hi 1	Pc	Latin	2113	Cowbell3 Open	Pc	Latin	2192	Shime Taiko1 Tsu	Pc	Ethnc
1956	Ghunguru	Pc	Pop	2035	Timbale1 Hi 2	Pc	Latin	2114	Mambo Bell Sw	Pc	Latin	2193	Shime Taiko1 Ku	Pc	Ethnc
1957	Wind Chime	Pc	Pop	2036	Timbale1 Hi 3	Pc	Latin	2115	Mambo Bell1	Pc	Latin	2194	Shime Taiko2 Ten	Pc	Ethnc
1958	Resin Block Small	Pc	Pop	2037	Timbale1 Lo 1-2	Pc	Latin	2116	Mambo Bell2	Pc	Latin	2195	Shime Taiko2 Tsu	Pc	Ethnc
1959	Resin Block Large	Pc	Pop	2038	Timbale1 Lo 1	Pc	Latin	2117	Mambo Bell Body	Pc	Latin	2196	Shime Taiko2 Ku	Pc	Ethnc
1960	OrchTamb Shake-Hit	Pc	Pop	2039	Timbale1 Lo 2	Pc	Latin	2118	ChaCha Bell Sw	Pc	Latin	2197	Tsuzumi Pon	Pc	Ethnc
1961	OrchTamb Shake 1-2	Pc	Pop	2040	Timbale1 Rim	Pc	Latin	2119	ChaCha Bell	Pc	Latin	2198	Tsuzumi Pu	Pc	Ethnc
1962	OrchTamb Shake 1	Pc	Pop	2041	Timbale1 Paila L	Pc	Latin	2120	Samba Tambourim Open	Pc	Latin	2199	Tsuzumi Chi	Pc	Ethnc
1963	OrchTamb Shake 2	Pc	Pop	2042	Timbale1 Paila H	Pc	Latin	2121	Samba Tambourim Slap	Pc	Latin	2200	Tsuzumi Ta	Pc	Ethnc
1964	OrchTamb Hit Close	Pc	Pop	2043	Timbale2 Hi Sw	Pc	Latin	2122	Samba Tambourim Mute	Pc	Latin	2201	Oo Kawa Chon	Pc	Ethnc
1965	OrchTamb Hit Open	Pc	Pop	2044	Timbale2 Hi 1	Pc	Latin	2123	Repique Mute	Pc	Latin	2202	Oo Kawa Tsu	Pc	Ethnc
1966	Conga1 Hi Tip	Pc	Latin	2045	Timbale2 Hi 2	Pc	Latin	2124	Repique Open 1-2	Pc	Latin	2203	Oo Kawa Ton	Pc	Ethnc
1967	Conga1 Hi Heel	Pc	Latin	2046	Timbale2 Hi Rim	Pc	Latin	2125	Repique Open 1	Pc	Latin	2204	Small Tabla Dom	Pc	Arabc
1968	Conga1 Hi Open 1-2	Pc	Latin	2047	Timbale2 Lo Sw	Pc	Latin	2126	Repique Open 2	Pc	Latin	2205	Small Tabla Snap	Pc	Arabc
1969	Conga1 Hi Open 1	Pc	Latin	2048	Timbale2 Lo 1	Pc	Latin	2127	Berimbau Med	Pc	Latin	2206	Small Tabla Sak	Pc	Arabc
1970	Conga1 Hi Open 2	Pc	Latin	2049	Timbale2 Lo 2	Pc	Latin	2128	Berimbau Hard	Pc	Latin	2207	Small Tabla Tak	Pc	Arabc
1971	Conga1 Hi Mute	Pc	Latin	2050	Timbale2 Lo Rim	Pc	Latin	2129	Log Drum1	Pc	Ethnc	2208	Big Tabla Dom	Pc	Arabc
1972	Conga1 Hi Slap Open	Pc	Latin	2051	Paila L	Pc	Latin	2130	Log Drum2	Pc	Ethnc	2209	Big Tabla Tak	Pc	Arabc
1973	Conga1 Hi Slap	Pc	Latin	2052	Paila H	Pc	Latin	2131	Djembe1 Edge	Pc	Ethnc	2210	Big Tabla Sak	Pc	Arabc
1974	Conga1 Hi SlpMute1-2	Pc	Latin	2053	Ganza Accent	Pc	Latin	2132	Djembe1 Mute	Pc	Ethnc	2211	Tabla Dom	Pc	Arabc
1975	Conga1 Hi SlapMute 1	Pc	Latin	2054	Ganza Back	Pc	Latin	2133	Djembe1 Open	Pc	Ethnc	2212	Tabla Tak1	Pc	Arabc

No.	Name	Main Category	Sub Category	No.	Name	Main Category	Sub Category	No.	Name	Main Category	Sub Category	No.	Name	Main Category	Sub Category
2213	Tabla Tak2	Pc	Arabc	2292	Riq Tek Mute 2	Pc	Arabc	2371	DarbTekelndFingA2	Pc	Arabc	2450	HipHop Clap9	Pc	Elec
2214	Tabla Tik1	Pc	Arabc	2293	Riq Teke Damped 1-2	Pc	Arabc	2372	DarbTekelndFingA3	Pc	Arabc	2451	HipHop Clap10	Pc	Elec
2215	Tabla Tik2	Pc	Arabc	2294	Riq Teke Damped 1	Pc	Arabc	2373	DarbTekelndFingB 1-3	Pc	Arabc	2452	HipHop Clap11	Pc	Elec
2216	Tabla Tik3	Pc	Arabc	2295	Riq Teke Damped 2	Pc	Arabc	2374	DarbTekelndFingB 1	Pc	Arabc	2453	HipHop Clap12	Pc	Elec
2217	Tabla Sak1	Pc	Arabc	2296	Riq Teke Flam	Pc	Arabc	2375	DarbTekelndFingB 2	Pc	Arabc	2454	HipHop Clap13	Pc	Elec
2218	Tabla Tremolo	Pc	Arabc	2297	RiqTekMuteMed 1-2	Pc	Arabc	2376	DarbTekelndFingB 3	Pc	Arabc	2455	HipHop Clap14	Pc	Elec
2219	Udu Finger	Pc	Arabc	2298	RiqTekMuteMed 1	Pc	Arabc	2377	DarbTekeOthFingA 1-3	Pc	Arabc	2456	HipHop Flex1	Pc	Elec
2220	Udu High	Pc	Arabc	2299	RiqTekMuteMed 2	Pc	Arabc	2378	DarbTekeOthFingA 1	Pc	Arabc	2457	HipHop Flex2	Pc	Elec
2221	Udu Low	Pc	Arabc	2300	RiqTekOpenShort 1-2	Pc	Arabc	2379	DarbTekeOthFingA 2	Pc	Arabc	2458	HipHop Snap1	Pc	Elec
2222	Udu Combi	Pc	Arabc	2301	RiqTekOpenShort 1	Pc	Arabc	2380	DarbTekeOthFingA 3	Pc	Arabc	2459	HipHop Snap2	Pc	Elec
2223	Barasim Dom	Pc	Arabc	2302	RiqTekOpenShort 2	Pc	Arabc	2381	DarbTekeOthFingB 1-3	Pc	Arabc	2460	Bd Snap 1-2	Dr	Kick
2224	Barasim Sak	Pc	Arabc	2303	RiqTekeOpenShort 1-2	Pc	Arabc	2382	DarbTekeOthFingB 1	Pc	Arabc	2461	Bd Snap 1	Dr	Kick
2225	Barasim Tak	Pc	Arabc	2304	RiqTekeOpenShort 1	Pc	Arabc	2383	DarbTekeOthFingB 2	Pc	Arabc	2462	Bd Snap 2	Dr	Kick
2226	Segal Dom	Pc	Arabc	2305	RiqTekeOpenShort 2	Pc	Arabc	2384	DarbTekeOthFingB 3	Pc	Arabc	2463	Bd Snap L1-2	Dr	Kick
2227	Segal Tak	Pc	Arabc	2306	Riq Tek Flam	Pc	Arabc	2385	Darbuka Slap 1-2	Pc	Arabc	2464	Bd Snap R1-2	Dr	Kick
2228	Twaisat1	Pc	Arabc	2307	Riq Cymbal 1-2	Pc	Arabc	2386	Darbuka Slap 1	Pc	Arabc	2465	Bd Snap L1	Dr	Kick
2229	Twaisat2	Pc	Arabc	2308	Riq Cymbal 1	Pc	Arabc	2387	Darbuka Slap 2	Pc	Arabc	2466	Bd Snap L2	Dr	Kick
2230	Twaisat3	Pc	Arabc	2309	Riq Cymbal 2	Pc	Arabc	2388	Darbuka SlapMed 1-2	Pc	Arabc	2467	Bd Snap R1	Dr	Kick
2231	Twaisat4	Pc	Arabc	2310	Riq Cymbal Mute 1-2	Pc	Arabc	2389	Darbuka SlapMed 1	Pc	Arabc	2468	Bd Snap R2	Dr	Kick
2232	AsmaDavulSideBdy 1-2	Pc	Arabc	2311	Riq Cymbal Mute 1	Pc	Arabc	2390	Darbuka SlapMed 3	Pc	Arabc	2469	Bd Tight 1-2	Dr	Kick
2233	AsmaDavulSideBody 1	Pc	Arabc	2312	Riq Cymbal Mute 2	Pc	Arabc	2391	Darbuka TekeOpenFlam	Pc	Arabc	2470	Bd Tight 1	Dr	Kick
2234	AsmaDavulSideBody 2	Pc	Arabc	2313	Riq Full Open	Pc	Arabc	2392	Darbuka RolliOpen	Pc	Arabc	2471	Bd Tight 2	Dr	Kick
2235	AsmaDavul L Side 1-2	Pc	Arabc	2314	Riq ShakeA 1-2	Pc	Arabc	2393	Darbuka TekeDampFlam	Pc	Arabc	2472	Bd Tight L1-2	Dr	Kick
2236	AsmaDavul L Side 1	Pc	Arabc	2315	Riq ShakeA 1	Pc	Arabc	2394	Darbuka Rolli Close	Pc	Arabc	2473	Bd Tight R1-2	Dr	Kick
2237	AsmaDavul L Side 2	Pc	Arabc	2316	Riq ShakeA 2	Pc	Arabc	2395	Darbuka TekDead 1-3	Pc	Arabc	2474	Bd Tight L1	Dr	Kick
2238	AsmaDavul Both Sides	Pc	Arabc	2317	Riq ShakeB 1-2	Pc	Arabc	2396	Darbuka TekDead 1	Pc	Arabc	2475	Bd Tight L2	Dr	Kick
2239	AsmaDavul R Side 1-2	Pc	Arabc	2318	Riq ShakeB 1	Pc	Arabc	2397	Darbuka TekDead 2	Pc	Arabc	2476	Bd Tight R1	Dr	Kick
2240	AsmaDavul R Side 1	Pc	Arabc	2319	Riq ShakeB 2	Pc	Arabc	2398	Darbuka TekDead 3	Pc	Arabc	2477	Bd Tight R2	Dr	Kick
2241	AsmaDavul R Side 2	Pc	Arabc	2320	Riq Tremolo	Pc	Arabc	2399	Darbuka TekDampd 1-3	Pc	Arabc	2478	Bd Ambience 1-2	Dr	Kick
2242	Koltuk Davul Dum 1-2	Pc	Arabc	2321	Hollo Dum 1-2	Pc	Arabc	2400	Darbuka TekDampd 1	Pc	Arabc	2479	Bd Ambience 1	Dr	Kick
2243	Koltuk Davul Dum 1	Pc	Arabc	2322	Hollo Dum 1	Pc	Arabc	2401	Darbuka TekDampd 2	Pc	Arabc	2480	Bd Ambience 2	Dr	Kick
2244	Koltuk Davul Dum 2	Pc	Arabc	2323	Hollo Dum 2	Pc	Arabc	2402	Darbuka TekDampd 3	Pc	Arabc	2481	Bd Ambience L1-2	Dr	Kick
2245	KoltukDavulTekeOp1-3	Pc	Arabc	2324	Hollo Slap 1-2	Pc	Arabc	2403	Darbuka TekeOpen 1-3	Pc	Arabc	2482	Bd Ambience R1-2	Dr	Kick
2246	KoltukDavulTekeOp 1	Pc	Arabc	2325	Hollo Slap 1	Pc	Arabc	2404	Darbuka TekeOpen 1	Pc	Arabc	2483	Bd Ambience L1	Dr	Kick
2247	KoltukDavulTekeOp 2	Pc	Arabc	2326	Hollo Slap 2	Pc	Arabc	2405	Darbuka TekeOpen 2	Pc	Arabc	2484	Bd Ambience L2	Dr	Kick
2248	KoltukDavulTekeOp 3	Pc	Arabc	2327	Hollo FingerDead 1-2	Pc	Arabc	2406	Darbuka TekeOpen 3	Pc	Arabc	2485	Bd Ambience R1	Dr	Kick
2249	KoltukDavulTekOp 1-3	Pc	Arabc	2328	Hollo FingerDead 1	Pc	Arabc	2407	Kasik 1-2	Pc	Arabc	2486	Bd Ambience R2	Dr	Kick
2250	KoltukDavulTekOp 1	Pc	Arabc	2329	Hollo FingerDead 2	Pc	Arabc	2408	Kasik 1	Pc	Arabc	2487	Bd Normal ST1-2	Dr	Kick
2251	KoltukDavulTekOp 2	Pc	Arabc	2330	Tombek Dum 1-2	Pc	Arabc	2409	Kasik 2	Pc	Arabc	2488	Bd Normal 1St	Dr	Kick
2252	KoltukDavulTekOp 3	Pc	Arabc	2331	Tombek Dum 1	Pc	Arabc	2410	Kasik Flam Dead	Pc	Arabc	2489	Bd Normal 2St	Kasik	Kick
2253	KoltukDavulOpenFlam	Pc	Arabc	2332	Tombek Dum 2	Pc	Arabc	2411	Kasik Flam	Pc	Arabc	2490	Bd Normal L1-2	Dr	Kick
2254	Bendir Dum 1-2	Pc	Arabc	2333	Tombek Slap 1-2	Pc	Arabc	2412	Bonges Dum 1-2	Pc	Arabc	2491	Bd Normal R1-2	Dr	Kick
2255	Bendir Dum 1	Pc	Arabc	2334	Tombek Slap 1	Pc	Arabc	2413	Bonges Dum 1	Pc	Arabc	2492	Bd Normal 1L	Dr	Kick
2256	Bendir Dum 2	Pc	Arabc	2335	Tombek Slap 2	Pc	Arabc	2414	Bonges Dum 2	Pc	Arabc	2493	Bd Normal 1R	Dr	Kick
2257	Bendir Tek 1-3	Pc	Arabc	2336	Tombek Tek 1-3	Pc	Arabc	2415	Bonges Tek 1-2	Pc	Arabc	2494	Bd Normal 2L	Dr	Kick
2258	Bendir Tek 1	Pc	Arabc	2337	Tombek Tek 1	Pc	Arabc	2416	Bonges Tek 1	Pc	Arabc	2495	Bd Normal 2R	Dr	Kick
2259	Bendir Tek 2	Pc	Arabc	2338	Tombek Tek 2	Pc	Arabc	2417	Bonges Tek 2	Pc	Arabc	2496	Bd Funk ST1-2	Dr	Kick
2260	Bendir Tek 3	Pc	Arabc	2339	Tombek Tek 3	Pc	Arabc	2418	Bonges Slap	Pc	Arabc	2497	Bd Funk 1St	Dr	Kick
2261	Bendir Teke 1-3	Pc	Arabc	2340	TombekTekelndFng 1-3	Pc	Arabc	2419	Bonges Tek Flam	Pc	Arabc	2498	Bd Funk 2St	Dr	Kick
2262	Bendir Teke 1	Pc	Arabc	2341	TombekTekelndFng 1	Pc	Arabc	2420	Bonges Tek Roll	Pc	Arabc	2499	Bd Funk L1-2	Dr	Kick
2263	Bendir Teke 2	Pc	Arabc	2342	TombekTekelndFng 2	Pc	Arabc	2421	Bonges Flam	Pc	Arabc	2500	Bd Funk R1-2	Dr	Kick
2264	Bendir Teke 3	Pc	Arabc	2343	TombekTekelndFng 3	Pc	Arabc	2422	Bonges Flam Hi	Pc	Arabc	2501	Bd Funk 1 L	Dr	Kick
2265	Bendir Teke OpenFlam	Pc	Arabc	2344	TombekTekeOthFng 1-3	Pc	Arabc	2423	Clap T9	Pc	Elec	2502	Bd Funk 1 R	Dr	Kick
2266	Bendir Slap 1-2	Pc	Arabc	2345	TombekTekeOthFng 1	Pc	Arabc	2424	Clap AnSm	Pc	Elec	2503	Bd Funk 2 L	Dr	Kick
2267	Bendir Slap 1	Pc	Arabc	2346	TombekTekeOthFng 2	Pc	Arabc	2425	Electric Clap1	Pc	Elec	2504	Bd Funk 2 R	Dr	Kick
2268	Bendir Slap 2	Pc	Arabc	2347	TombekTekeOthFng 3	Pc	Arabc	2426	Electric Clap2	Pc	Elec	2505	Bd High St	Dr	Kick
2269	Bendir Tek Dead 1-2	Pc	Arabc	2348	Tombek Tek Dead Sw	Pc	Arabc	2427	Conga T8	Pc	Elec	2506	Bd High L	Dr	Kick
2270	Bendir Tek Dead 1	Pc	Arabc	2349	Tombek Tek Dead	Pc	Arabc	2428	Cowbell T8	Pc	Elec	2507	Bd High R	Dr	Kick
2271	Bendir Tek Dead 2	Pc	Arabc	2350	Tombek Tek Flam	Pc	Arabc	2429	Cowbell RX11	Pc	Elec	2508	Bd Low St	Dr	Kick
2272	Bendir Teke Dead 1-2	Pc	Arabc	2351	Tombek Slap Med 1-2	Pc	Arabc	2430	Cowbell AnCR	Pc	Elec	2509	Bd Low L	Dr	Kick
2273	Bendir Teke Dead 1	Pc	Arabc	2352	Tombek Slap Med 1	Pc	Arabc	2431	Electric Cowbell	Pc	Elec	2510	Bd Low R	Dr	Kick
2274	Bendir Teke Dead 2	Pc	Arabc	2353	Tombek Slap Med 2	Pc	Arabc	2432	Analog Shaker	Pc	Elec	2511	Bd H Son St	Dr	Kick
2275	Sagal R Open	Pc	Arabc	2354	Tombek Teke 1-3	Pc	Arabc	2433	Tambourine RX5	Pc	Elec	2512	Bd H Son L	Dr	Kick
2276	Sagal R Close 1-2	Pc	Arabc	2355	Tombek Teke 1	Pc	Arabc	2434	Tambourine AnCR	Pc	Elec	2513	Bd H Son R	Dr	Kick
2277	Sagal R Close 1	Pc	Arabc	2356	Tombek Teke 2	Pc	Arabc	2435	Electric Tambourine1	Pc	Elec	2514	Bd L Son St	Dr	Kick
2278	Sagal R Close 2	Pc	Arabc	2357	Tombek Teke 3	Pc	Arabc	2436	Electric Tambourine2	Pc	Elec	2515	Bd L Son L	Dr	Kick
2279	Sagal L Open	Pc	Arabc	2358	Darbuka Dum 1-2	Pc	Arabc	2437	MaracasT8	Pc	Elec	2516	Bd L Son R	Dr	Kick
2280	Sagal L Close 1-2	Pc	Arabc	2359	Darbuka Dum 1	Pc	Arabc	2438	Electric Maracas	Pc	Elec	2517	Bd Funk Son St	Dr	Kick
2281	Sagal L Close 1	Pc	Arabc	2360	Darbuka Dum 2	Pc	Arabc	2439	Claves T8	Pc	Elec	2518	Bd Funk Son L	Dr	Kick
2282	Sagal L Close 2	Pc	Arabc	2361	Darbuka TekA 1-3	Pc	Arabc	2440	Electric Triangle	Pc	Elec	2519	Bd Funk Son R	Dr	Kick
2283	Riq Dum Mute	Pc	Arabc	2362	Darbuka TekA 1	Pc	Arabc	2441	Analog Click	Pc	Elec	2520	Bd Rock1 St	Dr	Kick
2284	Riq Dum Open 1-2	Pc	Arabc	2363	Darbuka TekA 2	Pc	Arabc	2442	HipHop Clap1	Pc	Elec	2521	Bd Rock1 L	Dr	Kick
2285	Riq Dum Open 1	Pc	Arabc	2364	Darbuka TekA 3	Pc	Arabc	2443	HipHop Clap2	Pc	Elec	2522	Bd Rock1 R	Dr	Kick
2286	Riq Dum Open 2	Pc	Arabc	2365	Darbuka TekB 1-3	Pc	Arabc	2444	HipHop Clap3	Pc	Elec	2523	Bd Rock2 St	Dr	Kick
2287	Riq Tek Open 1-2	Pc	Arabc	2366	Darbuka TekB 1	Pc	Arabc	2445	HipHop Clap4	Pc	Elec	2524	Bd Rock2 L	Dr	Kick
2288	Riq Tek Open 1	Pc	Arabc	2367	Darbuka TekB 2	Pc	Arabc	2446	HipHop Clap5	Pc	Elec	2525	Bd Rock2 R	Dr	Kick
2289	Riq Tek Open 2	Pc	Arabc	2368	Darbuka TekB 3	Pc	Arabc	2447	HipHop Clap6	Pc	Elec	2526	Bd Dry1	Dr	Kick
2290	Riq Tek Mute 1-2	Pc	Arabc	2369	DarbTekelndFingA 1-3	Pc	Arabc	2448	HipHop Clap7	Pc	Elec	2527	Bd Dry2	Dr	Kick
2291	Riq Tek Mute 1	Pc	Arabc	2370	DarbTekelndFingA 1	Pc	Arabc	2449	HipHop Clap8	Pc	Elec	2528	Bd Pop	Dr	Kick

No.	Name	Main Category	Sub Category	No.	Name	Main Category	Sub Category	No.	Name	Main Category	Sub Category	No.	Name	Main Category	Sub Category
2529	Bd Var1	Dr	Kick	2608	Bd Nlz Closed 2 R	Dr	Kick	2687	Bd Analog Tight	Dr	Kick	2766	Sd Strong S13	Dr	Snare
2530	Bd Var2	Dr	Kick	2609	Bd Nlz Open 1-2 St	Dr	Kick	2688	Bd AnaHard	Dr	Kick	2767	Sd Strong S14	Dr	Snare
2531	Bd Room1	Dr	Kick	2610	Bd Nlz Open 1-2 L	Dr	Kick	2689	Bd Lo-Fi	Dr	Kick	2768	Sd Strong L1-4	Dr	Snare
2532	Bd Room2	Dr	Kick	2611	Bd Nlz Open 1-2 R	Dr	Kick	2690	Bd ThickSkin	Dr	Kick	2769	Sd Strong R1-4	Dr	Snare
2533	Bd Room3	Dr	Kick	2612	Bd Nlz Open 1 St	Dr	Kick	2691	Bd Slimy	Dr	Kick	2770	Sd Strong L1	Dr	Snare
2534	Bd Jazz1-2St	Dr	Kick	2613	Bd Nlz Open 1 L	Dr	Kick	2692	Bd Elec1	Dr	Kick	2771	Sd Strong L2	Dr	Snare
2535	Bd Jazz1-2L	Dr	Kick	2614	Bd Nlz Open 1 R	Dr	Kick	2693	Bd Elec2	Dr	Kick	2772	Sd Strong L3	Dr	Snare
2536	Bd Jazz1-2R	Dr	Kick	2615	Bd Nlz Open 2 St	Dr	Kick	2694	Bd Elec3	Dr	Kick	2773	Sd Strong L4	Dr	Snare
2537	Bd Jazz1St	Dr	Kick	2616	Bd Nlz Open 2 L	Dr	Kick	2695	Bd Elec4	Dr	Kick	2774	Sd Strong R1	Dr	Snare
2538	Bd Jazz1L	Dr	Kick	2617	Bd Nlz Open 2 R	Dr	Kick	2696	Bd ElecComp1	Dr	Kick	2775	Sd Strong R2	Dr	Snare
2539	Bd Jazz1R	Dr	Kick	2618	Bd GranCasaA Open St	Dr	Kick	2697	Bd ElecComp2	Dr	Kick	2776	Sd Strong R3	Dr	Snare
2540	Bd Jazz2St	Dr	Kick	2619	Bd GranCasaA Open L	Dr	Kick	2698	Bd ElecComp3	Dr	Kick	2777	Sd Strong R4	Dr	Snare
2541	Bd Jazz2L	Dr	Kick	2620	Bd GranCasaA Open R	Dr	Kick	2699	Bd ElecFX1	Dr	Kick	2778	Sd Rng S11-4	Dr	Snare
2542	Bd Jazz2R	Dr	Kick	2621	Bd GranCasaA Mute St	Dr	Kick	2700	Bd ElecFX2	Dr	Kick	2779	Sd Rng S11-3	Dr	Snare
2543	Bd FK Jazz St	Dr	Kick	2622	Bd GranCasaA Mute L	Dr	Kick	2701	Bd ElecGate	Dr	Kick	2780	Sd Rng S12-4	Dr	Snare
2544	Bd FK Jazz L	Dr	Kick	2623	Bd GranCasaA Mute R	Dr	Kick	2702	Bd ElecClick	Dr	Kick	2781	Sd Rng S11-2	Dr	Snare
2545	Bd FK Jazz R	Dr	Kick	2624	Bd GranCasaB 1-3 St	Dr	Kick	2703	Bd ElecPower1	Dr	Kick	2782	Sd Rng S12-3	Dr	Snare
2546	Bd PowerA 1-2St	Dr	Kick	2625	Bd GranCasaB 1-3 L	Dr	Kick	2704	Bd ElecPower2	Dr	Kick	2783	Sd Rng S13-4	Dr	Snare
2547	Bd PowerA 1-2L	Dr	Kick	2626	Bd GranCasaB 1-3 R	Dr	Kick	2705	Bd HipHop1	Dr	Kick	2784	Sd Rng S11	Dr	Snare
2548	Bd PowerA 1-2R	Dr	Kick	2627	Bd GranCasaB 1 St	Dr	Kick	2706	Bd HipHop2	Dr	Kick	2785	Sd Rng S12	Dr	Snare
2549	Bd PowerA 1St	Dr	Kick	2628	Bd GranCasaB 1 L	Dr	Kick	2707	Bd HipHop3	Dr	Kick	2786	Sd Rng S13	Dr	Snare
2550	Bd PowerA 1L	Dr	Kick	2629	Bd GranCasaB 1 R	Dr	Kick	2708	Bd HipHop4	Dr	Kick	2787	Sd Rng S14	Dr	Snare
2551	Bd PowerA 1R	Dr	Kick	2630	Bd GranCasaB 2 St	Dr	Kick	2709	Bd HipHop5	Dr	Kick	2788	Sd Rng L1-4	Dr	Snare
2552	Bd PowerA 2St	Dr	Kick	2631	Bd GranCasaB 2 L	Dr	Kick	2710	Bd HipHop6	Dr	Kick	2789	Sd Rng R1-4	Dr	Snare
2553	Bd PowerA 2L	Dr	Kick	2632	Bd GranCasaB 2 R	Dr	Kick	2711	Bd HipHop7	Dr	Kick	2790	Sd Rng L1	Dr	Snare
2554	Bd PowerA 2R	Dr	Kick	2633	Bd GranCasaB 3 St	Dr	Kick	2712	Bd HipHop8	Dr	Kick	2791	Sd Rng L2	Dr	Snare
2555	Bd PowerB 1-2St	Dr	Kick	2634	Bd GranCasaB 3 L	Dr	Kick	2713	Bd HipHop9	Dr	Kick	2792	Sd Rng L3	Dr	Snare
2556	Bd PowerB 1-2L	Dr	Kick	2635	Bd GranCasaB 3 R	Dr	Kick	2714	Bd HipHop10	Dr	Kick	2793	Sd Rng L4	Dr	Snare
2557	Bd PowerB 1-2R	Dr	Kick	2636	Bd GranCasaB Hoop St	Dr	Kick	2715	Bd HipHop11	Dr	Kick	2794	Sd Rng R1	Dr	Snare
2558	Bd PowerB 1St	Dr	Kick	2637	Bd GranCasaB Hoop L	Dr	Kick	2716	Bd HipHop12	Dr	Kick	2795	Sd Rng R2	Dr	Snare
2559	Bd PowerB 1L	Dr	Kick	2638	Bd GranCasaB Hoop R	Dr	Kick	2717	Bd HipHop13	Dr	Kick	2796	Sd Rng R3	Dr	Snare
2560	Bd PowerB 1R	Dr	Kick	2639	Bd GranCasaB Mill St	Dr	Kick	2718	Sd Blid S11-4	Dr	Snare	2797	Sd Rng R4	Dr	Snare
2561	Bd PowerB 2St	Dr	Kick	2640	Bd GranCasaB Mill L	Dr	Kick	2719	Sd Blid S11-3	Dr	Snare	2798	Sd Normal S11-4	Dr	Snare
2562	Bd PowerB 2L	Dr	Kick	2641	Bd GranCasaB Mill R	Dr	Kick	2720	Sd Blid S12-4	Dr	Snare	2799	Sd Normal S11-3	Dr	Snare
2563	Bd PowerB 2R	Dr	Kick	2642	Bd Gate	Dr	Kick	2721	Sd Blid S11-2	Dr	Snare	2800	Sd Normal S12-4	Dr	Snare
2564	Bd Maple Close 1-2St	Dr	Kick	2643	Bd FX Gate	Dr	Kick	2722	Sd Blid S12-3	Dr	Snare	2801	Sd Normal S11-2	Dr	Snare
2565	Bd Maple Close 1-2 L	Dr	Kick	2644	Bd T9-1	Dr	Kick	2723	Sd Blid S13-4	Dr	Snare	2802	Sd Normal S12-3	Dr	Snare
2566	Bd Maple Close 1-2 R	Dr	Kick	2645	Bd T9-2	Dr	Kick	2724	Sd Blid S11	Dr	Snare	2803	Sd Normal S13-4	Dr	Snare
2567	Bd Maple Close 1 St	Dr	Kick	2646	Bd T9-3	Dr	Kick	2725	Sd Blid S12	Dr	Snare	2804	Sd Normal 1St	Dr	Snare
2568	Bd Maple Close 1 L	Dr	Kick	2647	Bd T9-4	Dr	Kick	2726	Sd Blid S13	Dr	Snare	2805	Sd Normal 2St	Dr	Snare
2569	Bd Maple Close 1 R	Dr	Kick	2648	Bd T9 Hd1	Dr	Kick	2727	Sd Blid S14	Dr	Snare	2806	Sd Normal 3St	Dr	Snare
2570	Bd Maple Close 2 St	Dr	Kick	2649	Bd T9 Hd2	Dr	Kick	2728	Sd Blid L1-4	Dr	Snare	2807	Sd Normal 4St	Dr	Snare
2571	Bd Maple Close 2 L	Dr	Kick	2650	Bd T9 Hd3	Dr	Kick	2729	Sd Blid R1-4	Dr	Snare	2808	Sd Normal L1-4	Dr	Snare
2572	Bd Maple Close 2 R	Dr	Kick	2651	Bd T8-1	Dr	Kick	2730	Sd Blid L1	Dr	Snare	2809	Sd Normal R1-4	Dr	Snare
2573	Bd Maple Open 1-2 St	Dr	Kick	2652	Bd T8-2	Dr	Kick	2731	Sd Blid L2	Dr	Snare	2810	Sd Normal 1L	Dr	Snare
2574	Bd Maple Open 1-2 L	Dr	Kick	2653	Bd T8-3	Dr	Kick	2732	Sd Blid L3	Dr	Snare	2811	Sd Normal 1R	Dr	Snare
2575	Bd Maple Open 1-2 R	Dr	Kick	2654	Bd AnSm	Dr	Kick	2733	Sd Blid L4	Dr	Snare	2812	Sd Normal 2L	Dr	Snare
2576	Bd Maple Open 1 St	Dr	Kick	2655	Bd AnCR	Dr	Kick	2734	Sd Blid R1	Dr	Snare	2813	Sd Normal 2R	Dr	Snare
2577	Bd Maple Open 1 L	Dr	Kick	2656	Bd RX11	Dr	Kick	2735	Sd Blid R2	Dr	Snare	2814	Sd Normal 3L	Dr	Snare
2578	Bd Maple Open 1 R	Dr	Kick	2657	Bd Human1	Dr	Kick	2736	Sd Blid R3	Dr	Snare	2815	Sd Normal 3R	Dr	Snare
2579	Bd Maple Open 2 St	Dr	Kick	2658	Bd Human2	Dr	Kick	2737	Sd Blid R4	Dr	Snare	2816	Sd Normal 4L	Dr	Snare
2580	Bd Maple Open 2 L	Dr	Kick	2659	Bd Blip	Dr	Kick	2738	Sd Soul S11-4	Dr	Snare	2817	Sd Normal 4R	Dr	Snare
2581	Bd Maple Open 2 R	Dr	Kick	2660	Bd BlipHd	Dr	Kick	2739	Sd Soul S11-3	Dr	Snare	2818	Sd Funk S11-3	Dr	Snare
2582	Bd Oak Open 1-2 St	Dr	Kick	2661	Bd Jungle1	Dr	Kick	2740	Sd Soul S12-4	Dr	Snare	2819	Sd Funk S11-2	Dr	Snare
2583	Bd Oak Open 1-2 L	Dr	Kick	2662	Bd Jungle2	Dr	Kick	2741	Sd Soul S11-2	Dr	Snare	2820	Sd Funk S12-3	Dr	Snare
2584	Bd Oak Open 1-2 R	Dr	Kick	2663	Bd Jungle3	Dr	Kick	2742	Sd Soul S12-3	Dr	Snare	2821	Sd Funk S11/3	Dr	Snare
2585	Bd Oak Open 1 St	Dr	Kick	2664	Bd D&B1	Dr	Kick	2743	Sd Soul S13-4	Dr	Snare	2822	Sd Funk 1St	Dr	Snare
2586	Bd Oak Open 1 L	Dr	Kick	2665	Bd D&B2	Dr	Kick	2744	Sd Soul L1-4	Dr	Snare	2823	Sd Funk 2St	Dr	Snare
2587	Bd Oak Open 1 R	Dr	Kick	2666	Bd R&B1	Dr	Kick	2745	Sd Soul R1-4	Dr	Snare	2824	Sd Funk 3St	Dr	Snare
2588	Bd Oak Open 2 St	Dr	Kick	2667	Bd R&B2	Dr	Kick	2746	Sd Soul S11	Dr	Snare	2825	Sd Funk L1-3	Dr	Snare
2589	Bd Oak Open 2 L	Dr	Kick	2668	Bd Hip Deep	Dr	Kick	2747	Sd Soul S12	Dr	Snare	2826	Sd Funk R1-3	Dr	Snare
2590	Bd Oak Open 2 R	Dr	Kick	2669	Bd Break Deep	Dr	Kick	2748	Sd Soul S13	Dr	Snare	2827	Sd Funk 1L	Dr	Snare
2591	Bd Oak Close 1-2 St	Dr	Kick	2670	Bd Break1	Dr	Kick	2749	Sd Soul S14	Dr	Snare	2828	Sd Funk 1R	Dr	Snare
2592	Bd Oak Close 1-2 L	Dr	Kick	2671	Bd Break2	Dr	Kick	2750	Sd Soul L1	Dr	Snare	2829	Sd Funk 2L	Dr	Snare
2593	Bd Oak Close 1-2 R	Dr	Kick	2672	Bd Break Heavy	Dr	Kick	2751	Sd Soul L2	Dr	Snare	2830	Sd Funk 2R	Dr	Snare
2594	Bd Oak Close 1 St	Dr	Kick	2673	Bd Break Hard	Dr	Kick	2752	Sd Soul L3	Dr	Snare	2831	Sd Funk 3L	Dr	Snare
2595	Bd Oak Close 1 L	Dr	Kick	2674	Bd Distortion1	Dr	Kick	2753	Sd Soul L4	Dr	Snare	2832	Sd Funk 3R	Dr	Snare
2596	Bd Oak Close 1 R	Dr	Kick	2675	Bd Distortion2	Dr	Kick	2754	Sd Soul R1	Dr	Snare	2833	Sd Funk Ay St	Dr	Snare
2597	Bd Oak Close 2 St	Dr	Kick	2676	Bd Distortion3	Dr	Kick	2755	Sd Soul R2	Dr	Snare	2834	Sd Funk Ay L	Dr	Snare
2598	Bd Oak Close 2 L	Dr	Kick	2677	Bd Distortion4	Dr	Kick	2756	Sd Soul R3	Dr	Snare	2835	Sd Funk Ay R	Dr	Snare
2599	Bd Oak Close 2 R	Dr	Kick	2678	Bd Distortion5	Dr	Kick	2757	Sd Soul R4	Dr	Snare	2836	Sd Basic S11-3	Dr	Snare
2600	Bd Nlz Closed 1-2 St	Dr	Kick	2679	Bd DistortionRM	Dr	Kick	2758	Sd Strong S11-4	Dr	Snare	2837	Sd Basic S11-2	Dr	Snare
2601	Bd Nlz Closed 1-2 L	Dr	Kick	2680	Bd +HH	Dr	Kick	2759	Sd Strong S11-3	Dr	Snare	2838	Sd Basic S12-3	Dr	Snare
2602	Bd Nlz Closed 1-2 R	Dr	Kick	2681	Bd FxHammer	Dr	Kick	2760	Sd Strong S12-4	Dr	Snare	2839	Sd Basic S11/3	Dr	Snare
2603	Bd Nlz Closed 1 St	Dr	Kick	2682	Bd ZapHard	Dr	Kick	2761	Sd Strong S11-2	Dr	Snare	2840	Sd Basic 1St	Dr	Snare
2604	Bd Nlz Closed 1 L	Dr	Kick	2683	Bd ZapMid	Dr	Kick	2762	Sd Strong S12-3	Dr	Snare	2841	Sd Basic 2St	Dr	Snare
2605	Bd Nlz Closed 1 R	Dr	Kick	2684	Bd Sustain	Dr	Kick	2763	Sd Strong S13-4	Dr	Snare	2842	Sd Basic 3St	Dr	Snare
2606	Bd Nlz Closed 2 St	Dr	Kick	2685	Bd TekPower	Dr	Kick	2764	Sd Strong S11	Dr	Snare	2843	Sd Basic L1-3	Dr	Snare
2607	Bd Nlz Closed 2 L	Dr	Kick	2686	Bd Hard Long	Dr	Kick	2765	Sd Strong S12	Dr	Snare	2844	Sd Basic R1-3	Dr	Snare

No.	Name	Main Category	Sub Category	No.	Name	Main Category	Sub Category	No.	Name	Main Category	Sub Category	No.	Name	Main Category	Sub Category
2845	Sd Basic 1L	Dr	Snare	2924	Sd Hip L1-2	Dr	Snare	3003	Sd PowerC 1-5L	Dr	Snare	3082	Sd Beech 1 R	Dr	Snare
2846	Sd Basic 1R	Dr	Snare	2925	Sd Hip R1-2	Dr	Snare	3004	Sd PowerC 1-5R	Dr	Snare	3083	Sd Beech 2 St	Dr	Snare
2847	Sd Basic 2L	Dr	Snare	2926	Sd Hip 1L	Dr	Snare	3005	Sd PowerC 1-4St	Dr	Snare	3084	Sd Beech 2 L	Dr	Snare
2848	Sd Basic 2R	Dr	Snare	2927	Sd Hip 1R	Dr	Snare	3006	Sd PowerC 1-4L	Dr	Snare	3085	Sd Beech 2 R	Dr	Snare
2849	Sd Basic 3L	Dr	Snare	2928	Sd Hip 2L	Dr	Snare	3007	Sd PowerC 1-4R	Dr	Snare	3086	Sd Beech 3 St	Dr	Snare
2850	Sd Basic 3R	Dr	Snare	2929	Sd Hip 2R	Dr	Snare	3008	Sd PowerC 1St	Dr	Snare	3087	Sd Beech 3 L	Dr	Snare
2851	Sd SonA S11-4	Dr	Snare	2930	Sd Rock Open1 St	Dr	Snare	3009	Sd PowerC 1L	Dr	Snare	3088	Sd Beech 3 R	Dr	Snare
2852	Sd SonA S11-3	Dr	Snare	2931	Sd Rock Open1 L	Dr	Snare	3010	Sd PowerC 1R	Dr	Snare	3089	Sd Beech 4 St	Dr	Snare
2853	Sd SonA S12-4	Dr	Snare	2932	Sd Rock Open1 R	Dr	Snare	3011	Sd PowerC 2St	Dr	Snare	3090	Sd Beech 4 L	Dr	Snare
2854	Sd SonA S11-2	Dr	Snare	2933	Sd Rock Mute1 St	Dr	Snare	3012	Sd PowerC 2L	Dr	Snare	3091	Sd Beech 4 R	Dr	Snare
2855	Sd SonA S12-3	Dr	Snare	2934	Sd Rock Mute1 L	Dr	Snare	3013	Sd PowerC 2R	Dr	Snare	3092	Sd Beech OpRm 1-2 St	Dr	Snare
2856	Sd SonA S13-4	Dr	Snare	2935	Sd Rock Mute1 R	Dr	Snare	3014	Sd PowerC 3St	Dr	Snare	3093	Sd Beech OpRm 1-2 L	Dr	Snare
2857	Sd SonA 1St	Dr	Snare	2936	Sd Rock Rim1 St	Dr	Snare	3015	Sd PowerC 3L	Dr	Snare	3094	Sd Beech OpRm 1-2 R	Dr	Snare
2858	Sd SonA 2St	Dr	Snare	2937	Sd Rock Rim1 L	Dr	Snare	3016	Sd PowerC 3R	Dr	Snare	3095	Sd Beech OpRm 1St	Dr	Snare
2859	Sd SonA 3St	Dr	Snare	2938	Sd Rock Rim1 R	Dr	Snare	3017	Sd PowerC 4St	Dr	Snare	3096	Sd Beech OpRm 1 L	Dr	Snare
2860	Sd SonA 4St	Dr	Snare	2939	Sd Rock Open2 St	Dr	Snare	3018	Sd PowerC 4L	Dr	Snare	3097	Sd Beech OpRm 1 R	Dr	Snare
2861	Sd SonA L1-4	Dr	Snare	2940	Sd Rock Open2 L	Dr	Snare	3019	Sd PowerC 4R	Dr	Snare	3098	Sd Beech OpRm 2 St	Dr	Snare
2862	Sd SonA R1-4	Dr	Snare	2941	Sd Rock Open2 R	Dr	Snare	3020	Sd PowerC 5St	Dr	Snare	3099	Sd Beech OpRm 2 L	Dr	Snare
2863	Sd SonA 1L	Dr	Snare	2942	Sd Rock Mute2 St	Dr	Snare	3021	Sd PowerC 5L	Dr	Snare	3100	Sd Beech OpRm 2 R	Dr	Snare
2864	Sd SonA 1R	Dr	Snare	2943	Sd Rock Mute2 L	Dr	Snare	3022	Sd PowerC 5R	Dr	Snare	3101	Sd Beech CiRm St	Dr	Snare
2865	Sd SonA 2L	Dr	Snare	2944	Sd Rock Mute2 R	Dr	Snare	3023	Sd PowerD 1-5St	Dr	Snare	3102	Sd Beech CiRm L	Dr	Snare
2866	Sd SonA 2R	Dr	Snare	2945	Sd Rock Rim2 St	Dr	Snare	3024	Sd PowerD 1-5L	Dr	Snare	3103	Sd Beech CiRm R	Dr	Snare
2867	Sd SonA 3L	Dr	Snare	2946	Sd Rock Rim2 L	Dr	Snare	3025	Sd PowerD 1-5R	Dr	Snare	3104	Sd Metal 1-4 St	Dr	Snare
2868	Sd SonA 3R	Dr	Snare	2947	Sd Rock Rim2 R	Dr	Snare	3026	Sd PowerD 1-4St	Dr	Snare	3105	Sd Metal 1-4 L	Dr	Snare
2869	Sd SonA 4L	Dr	Snare	2948	Sd Rock Flam St	Dr	Snare	3027	Sd PowerD 1-4L	Dr	Snare	3106	Sd Metal 1-4 R	Dr	Snare
2870	Sd SonA 4R	Dr	Snare	2949	Sd Rock Flam L	Dr	Snare	3028	Sd PowerD 1-4R	Dr	Snare	3107	Sd Metal 1-OpRm St	Dr	Snare
2871	Sd Blues S11-3	Dr	Snare	2950	Sd Rock Flam R	Dr	Snare	3029	Sd PowerD 1St	Dr	Snare	3108	Sd Metal 1-OpRm L	Dr	Snare
2872	Sd Blues S11-2	Dr	Snare	2951	Sd Piccolo	Dr	Snare	3030	Sd PowerD 1L	Dr	Snare	3109	Sd Metal 1-OpRm R	Dr	Snare
2873	Sd Blues S12-3	Dr	Snare	2952	Sd Piccolo Rim1	Dr	Snare	3031	Sd PowerD 1R	Dr	Snare	3110	Sd Metal 1 St	Dr	Snare
2874	Sd Blues S11/3	Dr	Snare	2953	Sd Piccolo Rim2	Dr	Snare	3032	Sd PowerD 2St	Dr	Snare	3111	Sd Metal 1 L	Dr	Snare
2875	Sd Blues 1St	Dr	Snare	2954	Sd Mid	Dr	Snare	3033	Sd PowerD 2L	Dr	Snare	3112	Sd Metal 1 R	Dr	Snare
2876	Sd Blues 2St	Dr	Snare	2955	Sd Mid Rim	Dr	Snare	3034	Sd PowerD 2R	Dr	Snare	3113	Sd Metal 2 St	Dr	Snare
2877	Sd Blues 3St	Dr	Snare	2956	Sd Ambience	Dr	Snare	3035	Sd PowerD 3St	Dr	Snare	3114	Sd Metal 2 L	Dr	Snare
2878	Sd Blues L1-3	Dr	Snare	2957	Sd PowerA 1-5St	Dr	Snare	3036	Sd PowerD 3L	Dr	Snare	3115	Sd Metal 2 R	Dr	Snare
2879	Sd Blues R1-3	Dr	Snare	2958	Sd PowerA 1-5L	Dr	Snare	3037	Sd PowerD 3R	Dr	Snare	3116	Sd Metal 3 St	Dr	Snare
2880	Sd Blues 1L	Dr	Snare	2959	Sd PowerA 1-5R	Dr	Snare	3038	Sd PowerD 4St	Dr	Snare	3117	Sd Metal 3 L	Dr	Snare
2881	Sd Blues 1R	Dr	Snare	2960	Sd PowerA 1-4St	Dr	Snare	3039	Sd PowerD 4L	Dr	Snare	3118	Sd Metal 3 R	Dr	Snare
2882	Sd Blues 2L	Dr	Snare	2961	Sd PowerA 1-4L	Dr	Snare	3040	Sd PowerD 4R	Dr	Snare	3119	Sd Metal 4 St	Dr	Snare
2883	Sd Blues 2R	Dr	Snare	2962	Sd PowerA 1-4R	Dr	Snare	3041	Sd PowerD 5St	Dr	Snare	3120	Sd Metal 4 L	Dr	Snare
2884	Sd Blues 3L	Dr	Snare	2963	Sd PowerA 1St	Dr	Snare	3042	Sd PowerD 5L	Dr	Snare	3121	Sd Metal 4 R	Dr	Snare
2885	Sd Blues 3R	Dr	Snare	2964	Sd PowerA 1L	Dr	Snare	3043	Sd PowerD 5R	Dr	Snare	3122	Sd Metal OpRm 1-2 St	Dr	Snare
2886	Sd BluesHeart S11-3	Dr	Snare	2965	Sd PowerA 1R	Dr	Snare	3044	Sd Oak 1-4 St	Dr	Snare	3123	Sd Metal OpRm 1-2 L	Dr	Snare
2887	Sd BluesHeart S11-2	Dr	Snare	2966	Sd PowerA 2St	Dr	Snare	3045	Sd Oak 1-4 L	Dr	Snare	3124	Sd Metal OpRm 1-2 R	Dr	Snare
2888	Sd BluesHeart S12-3	Dr	Snare	2967	Sd PowerA 2L	Dr	Snare	3046	Sd Oak 1-4 R	Dr	Snare	3125	Sd Metal OpRm 1 St	Dr	Snare
2889	Sd BluesHeart S11/3	Dr	Snare	2968	Sd PowerA 2R	Dr	Snare	3047	Sd Oak 1-OpRm St	Dr	Snare	3126	Sd Metal OpRm 1 L	Dr	Snare
2890	Sd BluesHeart 1St	Dr	Snare	2969	Sd PowerA 3St	Dr	Snare	3048	Sd Oak 1-OpRm L	Dr	Snare	3127	Sd Metal OpRm 1 R	Dr	Snare
2891	Sd BluesHeart 2St	Dr	Snare	2970	Sd PowerA 3L	Dr	Snare	3049	Sd Oak 1-OpRm R	Dr	Snare	3128	Sd Metal OpRm 2 St	Dr	Snare
2892	Sd BluesHeart 3St	Dr	Snare	2971	Sd PowerA 3R	Dr	Snare	3050	Sd Oak 1 St	Dr	Snare	3129	Sd Metal OpRm 2 L	Dr	Snare
2893	Sd BluesHeart L1-3	Dr	Snare	2972	Sd PowerA 4St	Dr	Snare	3051	Sd Oak 1 L	Dr	Snare	3130	Sd Metal OpRm 2 R	Dr	Snare
2894	Sd BluesHeart R1-3	Dr	Snare	2973	Sd PowerA 4L	Dr	Snare	3052	Sd Oak 1 R	Dr	Snare	3131	Sd Metal CiRm St	Dr	Snare
2895	Sd BluesHeart 1L	Dr	Snare	2974	Sd PowerA 4R	Dr	Snare	3053	Sd Oak 2 St	Dr	Snare	3132	Sd Metal CiRm L	Dr	Snare
2896	Sd BluesHeart 1R	Dr	Snare	2975	Sd PowerA 5St	Dr	Snare	3054	Sd Oak 2 L	Dr	Snare	3133	Sd Metal CiRm R	Dr	Snare
2897	Sd BluesHeart 2L	Dr	Snare	2976	Sd PowerA 5L	Dr	Snare	3055	Sd Oak 2 R	Dr	Snare	3134	Sd Metal SnRoll St	Dr	Snare
2898	Sd BluesHeart 2R	Dr	Snare	2977	Sd PowerA 5R	Dr	Snare	3056	Sd Oak 3 St	Dr	Snare	3135	Sd Metal SnRoll L	Dr	Snare
2899	Sd BluesHeart 3L	Dr	Snare	2978	Sd PowerB 1-5St	Dr	Snare	3057	Sd Oak 3 L	Dr	Snare	3136	Sd Metal SnRoll R	Dr	Snare
2900	Sd BluesHeart 3R	Dr	Snare	2979	Sd PowerB 1-5L	Dr	Snare	3058	Sd Oak 3 R	Dr	Snare	3137	Sd Njz 1-4 St	Dr	Snare
2901	Sd Tight S11-4	Dr	Snare	2980	Sd PowerB 1-5R	Dr	Snare	3059	Sd Oak 4 St	Dr	Snare	3138	Sd Njz 1-4 L	Dr	Snare
2902	Sd Tight S11-3	Dr	Snare	2981	Sd PowerB 1-4St	Dr	Snare	3060	Sd Oak 4 L	Dr	Snare	3139	Sd Njz 1-4 R	Dr	Snare
2903	Sd Tight S12-4	Dr	Snare	2982	Sd PowerB 1-4L	Dr	Snare	3061	Sd Oak 4 R	Dr	Snare	3140	Sd Njz 1-OpRm St	Dr	Snare
2904	Sd Tight S11-2	Dr	Snare	2983	Sd PowerB 1-4R	Dr	Snare	3062	Sd Oak OpRm 1-2 St	Dr	Snare	3141	Sd Njz 1-OpRm L	Dr	Snare
2905	Sd Tight S12-3	Dr	Snare	2984	Sd PowerB 1St	Dr	Snare	3063	Sd Oak OpRm 1-2 L	Dr	Snare	3142	Sd Njz 1-OpRm R	Dr	Snare
2906	Sd Tight S13-4	Dr	Snare	2985	Sd PowerB 1L	Dr	Snare	3064	Sd Oak OpRm 1-2 R	Dr	Snare	3143	Sd Njz 1 St	Dr	Snare
2907	Sd Tight 1St	Dr	Snare	2986	Sd PowerB 1R	Dr	Snare	3065	Sd Oak OpRm 1 St	Dr	Snare	3144	Sd Njz 1 L	Dr	Snare
2908	Sd Tight 2St	Dr	Snare	2987	Sd PowerB 2St	Dr	Snare	3066	Sd Oak OpRm 1 L	Dr	Snare	3145	Sd Njz 1 R	Dr	Snare
2909	Sd Tight 3St	Dr	Snare	2988	Sd PowerB 2L	Dr	Snare	3067	Sd Oak OpRm 1 R	Dr	Snare	3146	Sd Njz 2 St	Dr	Snare
2910	Sd Tight 4St	Dr	Snare	2989	Sd PowerB 2R	Dr	Snare	3068	Sd Oak OpRm 2 St	Dr	Snare	3147	Sd Njz 2 L	Dr	Snare
2911	Sd Tight L1-4	Dr	Snare	2990	Sd PowerB 3St	Dr	Snare	3069	Sd Oak OpRm 2 L	Dr	Snare	3148	Sd Njz 2 R	Dr	Snare
2912	Sd Tight R1-4	Dr	Snare	2991	Sd PowerB 3L	Dr	Snare	3070	Sd Oak OpRm 2 R	Dr	Snare	3149	Sd Njz 3 St	Dr	Snare
2913	Sd Tight 1L	Dr	Snare	2992	Sd PowerB 3R	Dr	Snare	3071	Sd Oak CiRm St	Dr	Snare	3150	Sd Njz 3 L	Dr	Snare
2914	Sd Tight 1R	Dr	Snare	2993	Sd PowerB 4St	Dr	Snare	3072	Sd Oak CiRm L	Dr	Snare	3151	Sd Njz 3 R	Dr	Snare
2915	Sd Tight 2L	Dr	Snare	2994	Sd PowerB 4L	Dr	Snare	3073	Sd Oak CiRm R	Dr	Snare	3152	Sd Njz 4 St	Dr	Snare
2916	Sd Tight 2R	Dr	Snare	2995	Sd PowerB 4R	Dr	Snare	3074	Sd Beech 1-4 St	Dr	Snare	3153	Sd Njz 4 L	Dr	Snare
2917	Sd Tight 3L	Dr	Snare	2996	Sd PowerB 5St	Dr	Snare	3075	Sd Beech 1-4 L	Dr	Snare	3154	Sd Njz 4 R	Dr	Snare
2918	Sd Tight 3R	Dr	Snare	2997	Sd PowerB 5L	Dr	Snare	3076	Sd Beech 1-4 R	Dr	Snare	3155	Sd Njz OpRm 1-2 St	Dr	Snare
2919	Sd Tight 4L	Dr	Snare	2998	Sd PowerB 5R	Dr	Snare	3077	Sd Beech 1-OpRm St	Dr	Snare	3156	Sd Njz OpRm 1-2 L	Dr	Snare
2920	Sd Tight 4R	Dr	Snare	2999	Sd PowerB 5St	Dr	Snare	3078	Sd Beech 1-OpRm L	Dr	Snare	3157	Sd Njz OpRm 1-2 R	Dr	Snare
2921	Sd Hip S11-2	Dr	Snare	3000	Sd PowerB SL	Dr	Snare	3079	Sd Beech 1-OpRm R	Dr	Snare	3158	Sd Njz OpRm 1 St	Dr	Snare
2922	Sd Hip 1St	Dr	Snare	3001	Sd PowerB SR	Dr	Snare	3080	Sd Beech 1 St	Dr	Snare	3159	Sd Njz OpRm 1 L	Dr	Snare
2923	Sd Hip 2St	Dr	Snare	3002	Sd PowerC 1-5St	Dr	Snare	3081	Sd Beech 1 L	Dr	Snare	3160	Sd Njz OpRm 1 R	Dr	Snare

No.	Name	Main Category	Sub Category	No.	Name	Main Category	Sub Category	No.	Name	Main Category	Sub Category	No.	Name	Main Category	Sub Category
3161	Sd Njz OpRim 2 St	Dr	Snare	3240	Sd OrchB 2 R	Dr	Snare	3319	Sd Hip2	Dr	Snare	3398	HH Pedal 1 L	Dr	HiHat
3162	Sd Njz OpRim 2 L	Dr	Snare	3241	Sd OrchC 1-4 St	Dr	Snare	3320	Sd Hip3	Dr	Snare	3399	HH Pedal 2 L	Dr	HiHat
3163	Sd Njz OpRim 2 R	Dr	Snare	3242	Sd OrchC 1-4 L	Dr	Snare	3321	Sd Hip Gate	Dr	Snare	3400	HH Pedal 3 L	Dr	HiHat
3164	Sd Njz ClRim St	Dr	Snare	3243	Sd OrchC 1-4 R	Dr	Snare	3322	Sd Hip Rim1	Dr	Snare	3401	HH Pedal 1 R	Dr	HiHat
3165	Sd Njz ClRim L	Dr	Snare	3244	Sd OrchC 1 St	Dr	Snare	3323	Sd Hip Rim2	Dr	Snare	3402	HH Pedal 2 R	Dr	HiHat
3166	Sd Njz ClRim R	Dr	Snare	3245	Sd OrchC 1 L	Dr	Snare	3324	Sd Hip Rim3	Dr	Snare	3403	HH Pedal 3 R	Dr	HiHat
3167	Sd Gate1	Dr	Snare	3246	Sd OrchC 1 R	Dr	Snare	3325	Sd Hip Rim4	Dr	Snare	3404	HH Pedal 1-3RL	Dr	HiHat
3168	Sd Gate2	Dr	Snare	3247	Sd OrchC 2 St	Dr	Snare	3326	Sd Hip Rim5	Dr	Snare	3405	HH Pedal 1 RL	Dr	HiHat
3169	Sd LdwHmono	Dr	Snare	3248	Sd OrchC 2 L	Dr	Snare	3327	Sd Break1	Dr	Snare	3406	HH Pedal 2 RL	Dr	HiHat
3170	Sd BreakRim	Dr	Snare	3249	Sd OrchC 2 R	Dr	Snare	3328	Sd Break2	Dr	Snare	3407	HH Pedal 3 RL	Dr	HiHat
3171	Sd Dry	Dr	Snare	3250	Sd OrchC 3 St	Dr	Snare	3329	Sd Break3	Dr	Snare	3408	HH Open 1-2St	Dr	HiHat
3172	Sd Heavy	Dr	Snare	3251	Sd OrchC 3 L	Dr	Snare	3330	Sd Break Heavy	Dr	Snare	3409	HH Open 1St	Dr	HiHat
3173	Sd GM	Dr	Snare	3252	Sd OrchC 3 R	Dr	Snare	3331	Sd Break Roll	Dr	Snare	3410	HH Open 2St	Dr	HiHat
3174	Sd Rock Stick1 St	Dr	Snare	3253	Sd OrchC 4 St	Dr	Snare	3332	Sd FX1	Dr	Snare	3411	HH Open 1-2L	Dr	HiHat
3175	Sd Rock Stick1 L	Dr	Snare	3254	Sd OrchC 4 L	Dr	Snare	3333	Sd FX2	Dr	Snare	3412	HH Open 1-2R	Dr	HiHat
3176	Sd Rock Stick1 R	Dr	Snare	3255	Sd OrchC 4 R	Dr	Snare	3334	Sd FX3	Dr	Snare	3413	HH Open 2L	Dr	HiHat
3177	Sd Rock Stick2 St	Dr	Snare	3256	Sd Orch Roll St	Dr	Snare	3335	Sd FX4	Dr	Snare	3414	HH Open 2L	Dr	HiHat
3178	Sd Rock Stick2 L	Dr	Snare	3257	Sd Orch Roll L	Dr	Snare	3336	Sd ClapAna	Dr	Snare	3415	HH Open 1R	Dr	HiHat
3179	Sd Rock Stick2 R	Dr	Snare	3258	Sd Orch Roll R	Dr	Snare	3337	Sd Dist	Dr	Snare	3416	HH Open 2R	Dr	HiHat
3180	Sd Hip Stick1	Dr	Snare	3259	Sd Field 1-4 St	Dr	Snare	3338	Sd Cut	Dr	Snare	3417	HH Open 1-2RL	Dr	HiHat
3181	Sd Hip Stick2	Dr	Snare	3260	Sd Field 1-4 L	Dr	Snare	3339	Sd Garg H	Dr	Snare	3418	HH Open 1RL	Dr	HiHat
3182	Sd Hip Stick3	Dr	Snare	3261	Sd Field 1-4 R	Dr	Snare	3340	Sd Garg L	Dr	Snare	3419	HH Open 2RL	Dr	HiHat
3183	Sd Hip Stick4	Dr	Snare	3262	Sd Field 1 St	Dr	Snare	3341	Sd FM	Dr	Snare	3420	HH Closed Foot St	Dr	HiHat
3184	Sd Hip Stick5	Dr	Snare	3263	Sd Field 1 L	Dr	Snare	3342	Sd FM Rim	Dr	Snare	3421	HH Closed Foot L	Dr	HiHat
3185	Sd Hip Stick6 St	Dr	Snare	3264	Sd Field 1 R	Dr	Snare	3343	Sd Syn	Dr	Snare	3422	HH Closed Foot R	Dr	HiHat
3186	Sd Hip Stick6 L	Dr	Snare	3265	Sd Field 2 St	Dr	Snare	3344	Sd Clappy	Dr	Snare	3423	HH Closed Foot RL	Dr	HiHat
3187	Sd Hip Stick6 R	Dr	Snare	3266	Sd Field 2 L	Dr	Snare	3345	Sd Timbr	Dr	Snare	3424	HH Half Open2 St	Dr	HiHat
3188	Sd Hip Stick7	Dr	Snare	3267	Sd Field 2 R	Dr	Snare	3346	Sd Wood	Dr	Snare	3425	HH Half Open2 L	Dr	HiHat
3189	Sd Hip Stick8	Dr	Snare	3268	Sd Field 3 St	Dr	Snare	3347	Sd Hammer	Dr	Snare	3426	HH Half Open2 R	Dr	HiHat
3190	Sd Closed Rim St	Dr	Snare	3269	Sd Field 3 L	Dr	Snare	3348	Sd Lo-Fi	Dr	Snare	3427	HH Half Open2 RL	Dr	HiHat
3191	Sd Closed Rim L	Dr	Snare	3270	Sd Field 3 R	Dr	Snare	3349	Sd Rim SE	Dr	Snare	3428	HH Open2 St	Dr	HiHat
3192	Sd Closed Rim R	Dr	Snare	3271	Sd Field 4 St	Dr	Snare	3350	Sd HipHop1	Dr	Snare	3429	HH Open2 L	Dr	HiHat
3193	Sd Closed Rim2	Dr	Snare	3272	Sd Field 4 L	Dr	Snare	3351	Sd HipHop2	Dr	Snare	3430	HH Open2 R	Dr	HiHat
3194	Sd Closed Rim3	Dr	Snare	3273	Sd Field 4 R	Dr	Snare	3352	Sd HipHop3	Dr	Snare	3431	HH Open2 RL	Dr	HiHat
3195	Sd RockRoll St	Dr	Snare	3274	Sd Elec1	Dr	Snare	3353	Sd HipHop5	Dr	Snare	3432	HH Closed Rock Sw St	Dr	HiHat
3196	Sd RockRoll L	Dr	Snare	3275	Sd Elec2	Dr	Snare	3354	Sd HipHop6	Dr	Snare	3433	HH Closed Rock Sw RL	Dr	HiHat
3197	Sd RockRoll R	Dr	Snare	3276	Sd Elec3	Dr	Snare	3355	Sd HipHop7	Dr	Snare	3434	HH Closed Rock S St	Dr	HiHat
3198	Sd RockRollID St	Dr	Snare	3277	Sd Elec4	Dr	Snare	3356	Sd HipHop9	Dr	Snare	3435	HH Closed Rock S RL	Dr	HiHat
3199	Sd RockRollID L	Dr	Snare	3278	Sd Elec5	Dr	Snare	3357	Sd HipHop10	Dr	Snare	3436	HH Closed Rock H St	Dr	HiHat
3200	Sd RockRollID R	Dr	Snare	3279	Sd Elec6	Dr	Snare	3358	Sd HipHop11	Dr	Snare	3437	HH Closed Rock H RL	Dr	HiHat
3201	Sd LiveRoll St	Dr	Snare	3280	Sd Elec7	Dr	Snare	3359	Sd HipHop12	Dr	Snare	3438	HH Closed Rock Sw L	Dr	HiHat
3202	Sd LiveRoll L	Dr	Snare	3281	Sd Elec8	Dr	Snare	3360	Sd HipHop13	Dr	Snare	3439	HH Closed Rock Sw R	Dr	HiHat
3203	Sd LiveRoll R	Dr	Snare	3282	Sd Elec9	Dr	Snare	3361	Sd HipHop14	Dr	Snare	3440	HH Closed Rock S L	Dr	HiHat
3204	Sd Roll Mono	Dr	Snare	3283	Sd Elec10	Dr	Snare	3362	Sd HipHop15	Dr	Snare	3441	HH Closed Rock S R	Dr	HiHat
3205	Sd Brush Soft St	Dr	Snare	3284	Sd Elec11	Dr	Snare	3363	Sd HipHop16	Dr	Snare	3442	HH Closed Rock H L	Dr	HiHat
3206	Sd Brush Soft L	Dr	Snare	3285	Sd Elec12	Dr	Snare	3364	Sd HipHop17	Dr	Snare	3443	HH Closed Rock H R	Dr	HiHat
3207	Sd Brush Soft R	Dr	Snare	3286	Sd T9-1	Dr	Snare	3365	Sd HipHop18	Dr	Snare	3444	HH Pedal Rock Sw St	Dr	HiHat
3208	Sd Brush Med St	Dr	Snare	3287	Sd T9-2	Dr	Snare	3366	Sd HipHop Rim1	Dr	Snare	3445	HH Pedal Rock Sw RL	Dr	HiHat
3209	Sd Brush Med L	Dr	Snare	3288	Sd T9-3	Dr	Snare	3367	Sd HipHop Rim2	Dr	Snare	3446	HH Pedal Rock Sw L	Dr	HiHat
3210	Sd Brush Med R	Dr	Snare	3289	Sd T9-4	Dr	Snare	3368	Sd HipHop Rim3	Dr	Snare	3447	HH Pedal Rock Sw R	Dr	HiHat
3211	Sd Brush vari St	Dr	Snare	3290	Sd T9-5	Dr	Snare	3369	Sd HipHop Rim4	Dr	Snare	3448	HH Closed Rock 2St	Dr	HiHat
3212	Sd Brush vari L	Dr	Snare	3291	Sd T9Gate	Dr	Snare	3370	Sd HipHop Rim5	Dr	Snare	3449	HH Closed Rock 2L	Dr	HiHat
3213	Sd Brush vari R	Dr	Snare	3292	Sd T9Rim	Dr	Snare	3371	Sd HipHop Rim6	Dr	Snare	3450	HH Closed Rock 2R	Dr	HiHat
3214	Sd Closed Rim4 St	Dr	Snare	3293	Sd T8-1	Dr	Snare	3372	HH Closed 1-4St	Dr	HiHat	3451	HH Closed Rock 2RL	Dr	HiHat
3215	Sd Closed Rim4 L	Dr	Snare	3294	Sd T8-2	Dr	Snare	3373	HH Closed 1St	Dr	HiHat	3452	HH Pedal Rock St	Dr	HiHat
3216	Sd Closed Rim4 R	Dr	Snare	3295	Sd T8-3	Dr	Snare	3374	HH Closed 2St	Dr	HiHat	3453	HH Pedal Rock L	Dr	HiHat
3217	Sd Brush Swir St	Dr	Snare	3296	Sd T8-4	Dr	Snare	3375	HH Closed 3St	Dr	HiHat	3454	HH Pedal Rock R	Dr	HiHat
3218	Sd Brush Swir L	Dr	Snare	3297	Sd T8-5	Dr	Snare	3376	HH Closed 4St	Dr	HiHat	3455	HH Pedal Rock RL	Dr	HiHat
3219	Sd Brush Swir R	Dr	Snare	3298	Sd T8 Rim	Dr	Snare	3377	HH Closed 1-4L	Dr	HiHat	3456	HH Open Rock Sw St	Dr	HiHat
3220	Sd Brush SwirAtt St	Dr	Snare	3299	Sd RX11 A	Dr	Snare	3378	HH Closed 1-4R	Dr	HiHat	3457	HH Open Rock Sw RL	Dr	HiHat
3221	Sd Brush SwirAtt L	Dr	Snare	3300	Sd RX11 B	Dr	Snare	3379	HH Closed 1L	Dr	HiHat	3458	HH Open Rock St	Dr	HiHat
3222	Sd Brush SwirAtt R	Dr	Snare	3301	Sd AnSm	Dr	Snare	3380	HH Closed 2L	Dr	HiHat	3459	HH Open Rock RL	Dr	HiHat
3223	Sd OrchA 1-2 St	Dr	Snare	3302	Sd AnSm Rim	Dr	Snare	3381	HH Closed 3L	Dr	HiHat	3460	HH Half Open Rock St	Dr	HiHat
3224	Sd OrchA 1 St	Dr	Snare	3303	Sd AnCR	Dr	Snare	3382	HH Closed 4L	Dr	HiHat	3461	HH Open Rock Sw L	Dr	HiHat
3225	Sd OrchA 2 St	Dr	Snare	3304	Sd AnCR Rim	Dr	Snare	3383	HH Closed 1R	Dr	HiHat	3462	HH Open Rock Sw R	Dr	HiHat
3226	Sd OrchA 1-2 L	Dr	Snare	3305	Sd Human1	Dr	Snare	3384	HH Closed 2R	Dr	HiHat	3463	HH Open Rock L	Dr	HiHat
3227	Sd OrchA 1-2 R	Dr	Snare	3306	Sd Human2	Dr	Snare	3385	HH Closed 3R	Dr	HiHat	3464	HH Open Rock R	Dr	HiHat
3228	Sd OrchA 1 L	Dr	Snare	3307	Sd Jungle1	Dr	Snare	3386	HH Closed 4R	Dr	HiHat	3465	HH Half Open Rock L	Dr	HiHat
3229	Sd OrchA 2 L	Dr	Snare	3308	Sd Jungle2	Dr	Snare	3387	HH Closed 1-4RL	Dr	HiHat	3466	HH Half Open Rock R	Dr	HiHat
3230	Sd OrchA 1 R	Dr	Snare	3309	Sd Jungle3	Dr	Snare	3388	HH Closed 1RL	Dr	HiHat	3467	HH Half Open Rock RL	Dr	HiHat
3231	Sd OrchA 2 R	Dr	Snare	3310	Sd JungleFX	Dr	Snare	3389	HH Closed 2RL	Dr	HiHat	3468	HH Closed Mono	Dr	HiHat
3232	Sd OrchB 1-2 St	Dr	Snare	3311	Sd D&B1	Dr	Snare	3390	HH Closed 3RL	Dr	HiHat	3469	HH Open Mono	Dr	HiHat
3233	Sd OrchB 1 St	Dr	Snare	3312	Sd D&B2	Dr	Snare	3391	HH Closed 4RL	Dr	HiHat	3470	HH Pedal Mono	Dr	HiHat
3234	Sd OrchB 2 St	Dr	Snare	3313	Sd D&B3	Dr	Snare	3392	HH Pedal 1-3St	Dr	HiHat	3471	HH Power ClTip 1-4St	Dr	HiHat
3235	Sd OrchB 1-2 L	Dr	Snare	3314	Sd D&B4	Dr	Snare	3393	HH Pedal 1 St	Dr	HiHat	3472	HH Power ClTip 1-4L	Dr	HiHat
3236	Sd OrchB 1-2 R	Dr	Snare	3315	Sd R&B1	Dr	Snare	3394	HH Pedal 2 St	Dr	HiHat	3473	HH Power ClTip 1-4R	Dr	HiHat
3237	Sd OrchB 1 L	Dr	Snare	3316	Sd R&B1 Rim	Dr	Snare	3395	HH Pedal 3 St	Dr	HiHat	3474	HH Power ClTip 1-4RL	Dr	HiHat
3238	Sd OrchB 2 L	Dr	Snare	3317	Sd R&B2	Dr	Snare	3396	HH Pedal 1-3 L	Dr	HiHat	3475	HH Power ClTip 1St	Dr	HiHat
3239	Sd OrchB 1 R	Dr	Snare	3318	Sd Hip1	Dr	Snare	3397	HH Pedal 1-3 R	Dr	HiHat	3476	HH Power ClTip 1L	Dr	HiHat

No.	Name	Main Category	Sub Category	No.	Name	Main Category	Sub Category	No.	Name	Main Category	Sub Category	No.	Name	Main Category	Sub Category
3477	HH Power CTip 1R	Dr	HiHat	3556	HH Dark Open 1 L	Dr	HiHat	3635	HH Open Syn	Dr	HiHat	3714	Tom Power05 2RL	Dr	Tom
3478	HH Power CTip 1RL	Dr	HiHat	3557	HH Dark Open 1 R	Dr	HiHat	3636	HH Closed FX	Dr	HiHat	3715	Tom Maple Hi 1-2 St	Dr	Tom
3479	HH Power CTip 2St	Dr	HiHat	3558	HH Dark Open 1 RL	Dr	HiHat	3637	HH Open FX	Dr	HiHat	3716	Tom Maple Hi 1-2 L	Dr	Tom
3480	HH Power CTip 2L	Dr	HiHat	3559	HH Dark Open 2 St	Dr	HiHat	3638	HH Open Human	Dr	HiHat	3717	Tom Maple Hi 1-2 R	Dr	Tom
3481	HH Power CTip 2R	Dr	HiHat	3560	HH Dark Open 2 L	Dr	HiHat	3639	Tom Hi St	Dr	Tom	3718	Tom Maple Hi 1-2 RL	Dr	Tom
3482	HH Power CTip 2RL	Dr	HiHat	3561	HH Dark Open 2 R	Dr	HiHat	3640	Tom Hi L	Dr	Tom	3719	Tom Maple Hi 1 St	Dr	Tom
3483	HH Power CTip 3St	Dr	HiHat	3562	HH Dark Open 2 RL	Dr	HiHat	3641	Tom Hi R	Dr	Tom	3720	Tom Maple Hi 1 L	Dr	Tom
3484	HH Power CTip 3L	Dr	HiHat	3563	HH NJz Closed 1-4 St	Dr	HiHat	3642	Tom Hi RL	Dr	Tom	3721	Tom Maple Hi 1 R	Dr	Tom
3485	HH Power CTip 3R	Dr	HiHat	3564	HH NJz Closed 1-4 L	Dr	HiHat	3643	Tom Mid St	Dr	Tom	3722	Tom Maple Hi 1 RL	Dr	Tom
3486	HH Power CTip 3RL	Dr	HiHat	3565	HH NJz Closed 1-4 R	Dr	HiHat	3644	Tom Mid L	Dr	Tom	3723	Tom Maple Hi 2 St	Dr	Tom
3487	HH Power CTip 4St	Dr	HiHat	3566	HH NJz Closed 1-4 RL	Dr	HiHat	3645	Tom Mid R	Dr	Tom	3724	Tom Maple Hi 2 L	Dr	Tom
3488	HH Power CTip 4L	Dr	HiHat	3567	HH NJz Closed 1 St	Dr	HiHat	3646	Tom Mid RL	Dr	Tom	3725	Tom Maple Hi 2 R	Dr	Tom
3489	HH Power CTip 4R	Dr	HiHat	3568	HH NJz Closed 1 L	Dr	HiHat	3647	Tom Low St	Dr	Tom	3726	Tom Maple Hi 2 RL	Dr	Tom
3490	HH Power CTip 4RL	Dr	HiHat	3569	HH NJz Closed 1 R	Dr	HiHat	3648	Tom Low L	Dr	Tom	3727	Tom Maple Mid 1-2 St	Dr	Tom
3491	HH Power CIEgde1-4St	Dr	HiHat	3570	HH NJz Closed 1 RL	Dr	HiHat	3649	Tom Low R	Dr	Tom	3728	Tom Maple Mid 1-2 L	Dr	Tom
3492	HH Power CIEgde1-4L	Dr	HiHat	3571	HH NJz Closed 2 St	Dr	HiHat	3650	Tom Low RL	Dr	Tom	3729	Tom Maple Mid 1-2 R	Dr	Tom
3493	HH Power CIEgde1-4R	Dr	HiHat	3572	HH NJz Closed 2 L	Dr	HiHat	3651	Tom Floor St	Dr	Tom	3730	Tom Maple Mid 1-2 RL	Dr	Tom
3494	HH Power CIEgde1-4RL	Dr	HiHat	3573	HH NJz Closed 2 R	Dr	HiHat	3652	Tom Floor L	Dr	Tom	3731	Tom Maple Mid 1 St	Dr	Tom
3495	HH Power CIEgde 1St	Dr	HiHat	3574	HH NJz Closed 2 RL	Dr	HiHat	3653	Tom Floor R	Dr	Tom	3732	Tom Maple Mid 1 L	Dr	Tom
3496	HH Power CIEgde 1L	Dr	HiHat	3575	HH NJz Closed 3 St	Dr	HiHat	3654	Tom Floor RL	Dr	Tom	3733	Tom Maple Mid 1 R	Dr	Tom
3497	HH Power CIEgde 1R	Dr	HiHat	3576	HH NJz Closed 3 L	Dr	HiHat	3655	Tom Rock Hi St	Dr	Tom	3734	Tom Maple Mid 1 RL	Dr	Tom
3498	HH Power CIEgde 1RL	Dr	HiHat	3577	HH NJz Closed 3 R	Dr	HiHat	3656	Tom Rock Hi L	Dr	Tom	3735	Tom Maple Mid 2 St	Dr	Tom
3499	HH Power CIEgde 2St	Dr	HiHat	3578	HH NJz Closed 3 RL	Dr	HiHat	3657	Tom Rock Hi R	Dr	Tom	3736	Tom Maple Mid 2 L	Dr	Tom
3500	HH Power CIEgde 2L	Dr	HiHat	3579	HH NJz Closed 4 St	Dr	HiHat	3658	Tom Rock Hi RL	Dr	Tom	3737	Tom Maple Mid 2 R	Dr	Tom
3501	HH Power CIEgde 2R	Dr	HiHat	3580	HH NJz Closed 4 L	Dr	HiHat	3659	Tom Rock Mid St	Dr	Tom	3738	Tom Maple Mid 2 RL	Dr	Tom
3502	HH Power CIEgde 2RL	Dr	HiHat	3581	HH NJz Closed 4 R	Dr	HiHat	3660	Tom Rock Mid L	Dr	Tom	3739	Tom Maple Fir 1-2 St	Dr	Tom
3503	HH Power CIEgde 3St	Dr	HiHat	3582	HH NJz Closed 4 RL	Dr	HiHat	3661	Tom Rock Mid R	Dr	Tom	3740	Tom Maple Fir 1-2 L	Dr	Tom
3504	HH Power CIEgde 3L	Dr	HiHat	3583	HH NJz Pedal 1-2 St	Dr	HiHat	3662	Tom Rock Mid RL	Dr	Tom	3741	Tom Maple Fir 1-2 R	Dr	Tom
3505	HH Power CIEgde 3R	Dr	HiHat	3584	HH NJz Pedal 1-2 L	Dr	HiHat	3663	Tom Rock Low St	Dr	Tom	3742	Tom Maple Fir 1-2 RL	Dr	Tom
3506	HH Power CIEgde 3RL	Dr	HiHat	3585	HH NJz Pedal 1-2 R	Dr	HiHat	3664	Tom Rock Low L	Dr	Tom	3743	Tom Maple Fir 1 St	Dr	Tom
3507	HH Power CIEgde 4St	Dr	HiHat	3586	HH NJz Pedal 1-2 RL	Dr	HiHat	3665	Tom Rock Low R	Dr	Tom	3744	Tom Maple Fir 1 L	Dr	Tom
3508	HH Power CIEgde 4L	Dr	HiHat	3587	HH NJz Pedal 1 St	Dr	HiHat	3666	Tom Rock Low RL	Dr	Tom	3745	Tom Maple Fir 1 R	Dr	Tom
3509	HH Power CIEgde 4R	Dr	HiHat	3588	HH NJz Pedal 1 L	Dr	HiHat	3667	Tom Power01 1-2St	Dr	Tom	3746	Tom Maple Fir 1 RL	Dr	Tom
3510	HH Power CIEgde 4RL	Dr	HiHat	3589	HH NJz Pedal 1 R	Dr	HiHat	3668	Tom Power01 1-2L	Dr	Tom	3747	Tom Maple Fir 2 St	Dr	Tom
3511	HH Power CIPedal St	Dr	HiHat	3590	HH NJz Pedal 1 RL	Dr	HiHat	3669	Tom Power01 1-2R	Dr	Tom	3748	Tom Maple Fir 2 L	Dr	Tom
3512	HH Power CIPedal L	Dr	HiHat	3591	HH NJz Pedal 2 St	Dr	HiHat	3670	Tom Power01 1-2RL	Dr	Tom	3749	Tom Maple Fir 2 R	Dr	Tom
3513	HH Power CIPedal R	Dr	HiHat	3592	HH NJz Pedal 2 L	Dr	HiHat	3671	Tom Power01 1St	Dr	Tom	3750	Tom Maple Fir 2 RL	Dr	Tom
3514	HH Power CIPedal RL	Dr	HiHat	3593	HH NJz Pedal 2 R	Dr	HiHat	3672	Tom Power01 1L	Dr	Tom	3751	Tom Oak Hi 1-2 St	Dr	Tom
3515	HH Power Open EdgeSt	Dr	HiHat	3594	HH NJz Pedal 2 RL	Dr	HiHat	3673	Tom Power01 1R	Dr	Tom	3752	Tom Oak Hi 1-2 L	Dr	Tom
3516	HH Power Open EdgeL	Dr	HiHat	3595	HH NJz Open 1-2 St	Dr	HiHat	3674	Tom Power01 1RL	Dr	Tom	3753	Tom Oak Hi 1-2 R	Dr	Tom
3517	HH Power Open EdgeR	Dr	HiHat	3596	HH NJz Open 1-2 L	Dr	HiHat	3675	Tom Power01 2St	Dr	Tom	3754	Tom Oak Hi 1-2 RL	Dr	Tom
3518	HH Power Open EdgeRL	Dr	HiHat	3597	HH NJz Open 1-2 R	Dr	HiHat	3676	Tom Power01 2L	Dr	Tom	3755	Tom Oak Hi 1 St	Dr	Tom
3519	HH Dark Closed 1-4St	Dr	HiHat	3598	HH NJz Open 1-2 RL	Dr	HiHat	3677	Tom Power01 2R	Dr	Tom	3756	Tom Oak Hi 1 L	Dr	Tom
3520	HH Dark Closed 1-4 L	Dr	HiHat	3599	HH NJz Open 1 St	Dr	HiHat	3678	Tom Power01 2RL	Dr	Tom	3757	Tom Oak Hi 1 R	Dr	Tom
3521	HH Dark Closed 1-4 R	Dr	HiHat	3600	HH NJz Open 1 L	Dr	HiHat	3679	Tom Power03 1-2St	Dr	Tom	3758	Tom Oak Hi 1 RL	Dr	Tom
3522	HH Dark Closed 1-4RL	Dr	HiHat	3601	HH NJz Open 1 R	Dr	HiHat	3680	Tom Power03 1-2L	Dr	Tom	3759	Tom Oak Hi 2 St	Dr	Tom
3523	HH Dark Closed 1 St	Dr	HiHat	3602	HH NJz Open 1 RL	Dr	HiHat	3681	Tom Power03 1-2R	Dr	Tom	3760	Tom Oak Hi 2 L	Dr	Tom
3524	HH Dark Closed 1 L	Dr	HiHat	3603	HH NJz Open 2 St	Dr	HiHat	3682	Tom Power03 1-2RL	Dr	Tom	3761	Tom Oak Hi 2 R	Dr	Tom
3525	HH Dark Closed 1 R	Dr	HiHat	3604	HH NJz Open 2 L	Dr	HiHat	3683	Tom Power03 1St	Dr	Tom	3762	Tom Oak Hi 2 RL	Dr	Tom
3526	HH Dark Closed 1 RL	Dr	HiHat	3605	HH NJz Open 2 R	Dr	HiHat	3684	Tom Power03 1L	Dr	Tom	3763	Tom Oak Mid 1-2 St	Dr	Tom
3527	HH Dark Closed 2 St	Dr	HiHat	3606	HH NJz Open 2 RL	Dr	HiHat	3685	Tom Power03 1R	Dr	Tom	3764	Tom Oak Mid 1-2 L	Dr	Tom
3528	HH Dark Closed 2 L	Dr	HiHat	3607	HH Brush Closed	Dr	HiHat	3686	Tom Power03 1RL	Dr	Tom	3765	Tom Oak Mid 1-2 R	Dr	Tom
3529	HH Dark Closed 2 R	Dr	HiHat	3608	HH Brush Open	Dr	HiHat	3687	Tom Power03 2St	Dr	Tom	3766	Tom Oak Mid 1-2 RL	Dr	Tom
3530	HH Dark Closed 2 RL	Dr	HiHat	3609	HH Brush Pedal	Dr	HiHat	3688	Tom Power03 2L	Dr	Tom	3767	Tom Oak Mid 1 St	Dr	Tom
3531	HH Dark Closed 3 St	Dr	HiHat	3610	HH Closed T9	Dr	HiHat	3689	Tom Power03 2R	Dr	Tom	3768	Tom Oak Mid 1 L	Dr	Tom
3532	HH Dark Closed 3 L	Dr	HiHat	3611	HH Open T9	Dr	HiHat	3690	Tom Power03 2RL	Dr	Tom	3769	Tom Oak Mid 1 R	Dr	Tom
3533	HH Dark Closed 3 R	Dr	HiHat	3612	HH Closed T8-1	Dr	HiHat	3691	Tom Power04 1-2St	Dr	Tom	3770	Tom Oak Mid 1 RL	Dr	Tom
3534	HH Dark Closed 3 RL	Dr	HiHat	3613	HH Open T8-1	Dr	HiHat	3692	Tom Power04 1-2L	Dr	Tom	3771	Tom Oak Mid 2 St	Dr	Tom
3535	HH Dark Closed 4 St	Dr	HiHat	3614	HH Closed T8-2	Dr	HiHat	3693	Tom Power04 1-2R	Dr	Tom	3772	Tom Oak Mid 2 L	Dr	Tom
3536	HH Dark Closed 4 L	Dr	HiHat	3615	HH Open T8-2	Dr	HiHat	3694	Tom Power04 1-2RL	Dr	Tom	3773	Tom Oak Mid 2 R	Dr	Tom
3537	HH Dark Closed 4 R	Dr	HiHat	3616	HH Closed RX5	Dr	HiHat	3695	Tom Power04 1St	Dr	Tom	3774	Tom Oak Mid 2 RL	Dr	Tom
3538	HH Dark Closed 4 RL	Dr	HiHat	3617	HH Closed RX11	Dr	HiHat	3696	Tom Power04 1L	Dr	Tom	3775	Tom Oak Floor 1-2 St	Dr	Tom
3539	HH Dark Pedal 1-2 St	Dr	HiHat	3618	HH Open RX11	Dr	HiHat	3697	Tom Power04 1R	Dr	Tom	3776	Tom Oak Floor 1-2 L	Dr	Tom
3540	HH Dark Pedal 1-2 L	Dr	HiHat	3619	HH Closed AnCR	Dr	HiHat	3698	Tom Power04 1RL	Dr	Tom	3777	Tom Oak Floor 1-2 R	Dr	Tom
3541	HH Dark Pedal 1-2 R	Dr	HiHat	3620	HH Open AnCR	Dr	HiHat	3699	Tom Power04 2St	Dr	Tom	3778	Tom Oak Floor 1-2 RL	Dr	Tom
3542	HH Dark Pedal 1-2 RL	Dr	HiHat	3621	HH Closed Break	Dr	HiHat	3700	Tom Power04 2L	Dr	Tom	3779	Tom Oak Floor 1 St	Dr	Tom
3543	HH Dark Pedal 1 St	Dr	HiHat	3622	HH Pedal Break	Dr	HiHat	3701	Tom Power04 2R	Dr	Tom	3780	Tom Oak Floor 1 L	Dr	Tom
3544	HH Dark Pedal 1 L	Dr	HiHat	3623	HH Closed D&B	Dr	HiHat	3702	Tom Power04 2RL	Dr	Tom	3781	Tom Oak Floor 1 R	Dr	Tom
3545	HH Dark Pedal 1 R	Dr	HiHat	3624	HH Pedal D&B	Dr	HiHat	3703	Tom Power05 1-2St	Dr	Tom	3782	Tom Oak Floor 1 RL	Dr	Tom
3546	HH Dark Pedal 1 RL	Dr	HiHat	3625	HH Open D&B	Dr	HiHat	3704	Tom Power05 1-2L	Dr	Tom	3783	Tom Oak Floor 2 St	Dr	Tom
3547	HH Dark Pedal 2 St	Dr	HiHat	3626	HH Reverse D&B	Dr	HiHat	3705	Tom Power05 1-2R	Dr	Tom	3784	Tom Oak Floor 2 L	Dr	Tom
3548	HH Dark Pedal 2 L	Dr	HiHat	3627	HH Closed Tek	Dr	HiHat	3706	Tom Power05 1-2RL	Dr	Tom	3785	Tom Oak Floor 2 R	Dr	Tom
3549	HH Dark Pedal 2 R	Dr	HiHat	3628	HH Open Tek	Dr	HiHat	3707	Tom Power05 1St	Dr	Tom	3786	Tom Oak Floor 2 RL	Dr	Tom
3550	HH Dark Pedal 2 RL	Dr	HiHat	3629	HH Closed Hip	Dr	HiHat	3708	Tom Power05 1L	Dr	Tom	3787	Tom NJz Mid 1-2 St	Dr	Tom
3551	HH Dark Open 1-2 St	Dr	HiHat	3630	HH Pedal Hip	Dr	HiHat	3709	Tom Power05 1R	Dr	Tom	3788	Tom NJz Mid 1-2 L	Dr	Tom
3552	HH Dark Open 1-2 L	Dr	HiHat	3631	HH Open Hip	Dr	HiHat	3710	Tom Power05 1RL	Dr	Tom	3789	Tom NJz Mid 1-2 R	Dr	Tom
3553	HH Dark Open 1-2 R	Dr	HiHat	3632	HH Closed Lo-Fi	Dr	HiHat	3711	Tom Power05 2St	Dr	Tom	3790	Tom NJz Mid 1-2 RL	Dr	Tom
3554	HH Dark Open 1-2 RL	Dr	HiHat	3633	HH Open Lo-Fi	Dr	HiHat	3712	Tom Power05 2L	Dr	Tom	3791	Tom NJz Mid 1 St	Dr	Tom
3555	HH Dark Open 1 St	Dr	HiHat	3634	HH Closed Syn	Dr	HiHat	3713	Tom Power05 2R	Dr	Tom	3792	Tom NJz Mid 1 L	Dr	Tom

No.	Name	Main Category	Sub Category
3793	Tom Njz Mid 1 R	Dr	Tom
3794	Tom Njz Mid 1 RL	Dr	Tom
3795	Tom Njz Mid 2 St	Dr	Tom
3796	Tom Njz Mid 2 L	Dr	Tom
3797	Tom Njz Mid 2 R	Dr	Tom
3798	Tom Njz Mid 2 RL	Dr	Tom
3799	Tom Njz Low 1-2 St	Dr	Tom
3800	Tom Njz Low 1-2 L	Dr	Tom
3801	Tom Njz Low 1-2 R	Dr	Tom
3802	Tom Njz Low 1-2 RL	Dr	Tom
3803	Tom Njz Low 1 St	Dr	Tom
3804	Tom Njz Low 1 L	Dr	Tom
3805	Tom Njz Low 1 R	Dr	Tom
3806	Tom Njz Low 1 RL	Dr	Tom
3807	Tom Njz Low 2 St	Dr	Tom
3808	Tom Njz Low 2 L	Dr	Tom
3809	Tom Njz Low 2 R	Dr	Tom
3810	Tom Njz Low 2 RL	Dr	Tom
3811	Tom Njz Floor 1-2 St	Dr	Tom
3812	Tom Njz Floor 1-2 L	Dr	Tom
3813	Tom Njz Floor 1-2 R	Dr	Tom
3814	Tom Njz Floor 1-2 RL	Dr	Tom
3815	Tom Njz Floor 1 St	Dr	Tom
3816	Tom Njz Floor 1 L	Dr	Tom
3817	Tom Njz Floor 1 R	Dr	Tom
3818	Tom Njz Floor 1 RL	Dr	Tom
3819	Tom Njz Floor 2 St	Dr	Tom
3820	Tom Njz Floor 2 L	Dr	Tom
3821	Tom Njz Floor 2 R	Dr	Tom
3822	Tom Njz Floor 2 RL	Dr	Tom
3823	Tom Brush Hi St	Dr	Tom
3824	Tom Brush Hi L	Dr	Tom
3825	Tom Brush Hi R	Dr	Tom
3826	Tom Brush Hi RL	Dr	Tom
3827	Tom Brush Mid St	Dr	Tom
3828	Tom Brush Mid L	Dr	Tom
3829	Tom Brush Mid R	Dr	Tom
3830	Tom Brush Mid RL	Dr	Tom
3831	Tom Brush Low St	Dr	Tom
3832	Tom Brush Low L	Dr	Tom
3833	Tom Brush Low R	Dr	Tom
3834	Tom Brush Low RL	Dr	Tom
3835	Tom Brush Floor St	Dr	Tom
3836	Tom Brush Floor L	Dr	Tom
3837	Tom Brush Floor R	Dr	Tom
3838	Tom Brush Floor RL	Dr	Tom
3839	Tom Mono Hi	Dr	Tom
3840	Tom Mono Lo	Dr	Tom
3841	Tom Dry Hi	Dr	Tom
3842	Tom Dry Lo	Dr	Tom
3843	Rotary Tom Hi 1-2	Dr	Tom
3844	Rotary Tom Hi 1	Dr	Tom
3845	Rotary Tom Hi 2	Dr	Tom
3846	Rotary Tom Mid 1-2	Dr	Tom
3847	Rotary Tom Mid 1	Dr	Tom
3848	Rotary Tom Mid 2	Dr	Tom
3849	Rotary Tom Lo 1-2	Dr	Tom
3850	Rotary Tom Lo 1	Dr	Tom
3851	Rotary Tom Lo 2	Dr	Tom
3852	Tom Ambience Hi	Dr	Tom
3853	Tom Ambience Lo	Dr	Tom
3854	Tom T9 Hi	Dr	Tom
3855	Tom T9 Lo	Dr	Tom
3856	Tom T8	Dr	Tom
3857	Tom Syn1	Dr	Tom
3858	Tom Syn2	Dr	Tom
3859	Tom AnSm	Dr	Tom
3860	Tom Dist Hi	Dr	Tom
3861	Tom Dist Lo	Dr	Tom
3862	Tom RX11	Dr	Tom
3863	Crash1 St	Dr	Cymbi
3864	Crash1 L	Dr	Cymbi
3865	Crash1 R	Dr	Cymbi
3866	Crash1 RL	Dr	Cymbi
3867	Crash2 St	Dr	Cymbi
3868	Crash2 L	Dr	Cymbi
3869	Crash2 R	Dr	Cymbi
3870	Crash2 RL	Dr	Cymbi
3871	Crash3	Dr	Cymbi

No.	Name	Main Category	Sub Category
3872	Crash4	Dr	Cymbi
3873	Crash Brite St	Dr	Cymbi
3874	Crash Brite L	Dr	Cymbi
3875	Crash Brite R	Dr	Cymbi
3876	Crash Brite RL	Dr	Cymbi
3877	Crash Dark St	Dr	Cymbi
3878	Crash Dark L	Dr	Cymbi
3879	Crash Dark R	Dr	Cymbi
3880	Crash Dark RL	Dr	Cymbi
3881	Crash NjzA St	Dr	Cymbi
3882	Crash NjzA L	Dr	Cymbi
3883	Crash NjzA R	Dr	Cymbi
3884	Crash NjzA RL	Dr	Cymbi
3885	Crash NjzB St	Dr	Cymbi
3886	Crash NjzB L	Dr	Cymbi
3887	Crash NjzB R	Dr	Cymbi
3888	Crash NjzB RL	Dr	Cymbi
3889	Crash Brush1 St	Dr	Cymbi
3890	Crash Brush1 L	Dr	Cymbi
3891	Crash Brush1 R	Dr	Cymbi
3892	Crash Brush1 RL	Dr	Cymbi
3893	Crash Brush Cup St	Dr	Cymbi
3894	Crash Brush Cup L	Dr	Cymbi
3895	Crash Brush Cup R	Dr	Cymbi
3896	Crash Brush Cup RL	Dr	Cymbi
3897	Crash Brush2 St	Dr	Cymbi
3898	Crash Brush2 L	Dr	Cymbi
3899	Crash Brush2 R	Dr	Cymbi
3900	Crash Brush2 RL	Dr	Cymbi
3901	Hand Cymbal Open St	Dr	Cymbi
3902	Hand Cymbal Open L	Dr	Cymbi
3903	Hand Cymbal Open R	Dr	Cymbi
3904	Hand Cymbal Mute St	Dr	Cymbi
3905	Hand Cymbal Mute L	Dr	Cymbi
3906	Hand Cymbal Mute R	Dr	Cymbi
3907	Ride1 St	Dr	Cymbi
3908	Ride1 L	Dr	Cymbi
3909	Ride1 R	Dr	Cymbi
3910	Ride1 RL	Dr	Cymbi
3911	Ride2 St	Dr	Cymbi
3912	Ride2 L	Dr	Cymbi
3913	Ride2 R	Dr	Cymbi
3914	Ride2 RL	Dr	Cymbi
3915	Ride Brite St	Dr	Cymbi
3916	Ride Brite L	Dr	Cymbi
3917	Ride Brite R	Dr	Cymbi
3918	Ride Brite RL	Dr	Cymbi
3919	Ride Brite Cup St	Dr	Cymbi
3920	Ride Brite Cup L	Dr	Cymbi
3921	Ride Brite Cup R	Dr	Cymbi
3922	Ride Brite Cup RL	Dr	Cymbi
3923	Ride Warm St	Dr	Cymbi
3924	Ride Warm L	Dr	Cymbi
3925	Ride Warm R	Dr	Cymbi
3926	Ride Warm RL	Dr	Cymbi
3927	Ride Njz St	Dr	Cymbi
3928	Ride Njz L	Dr	Cymbi
3929	Ride Njz R	Dr	Cymbi
3930	Ride Njz RL	Dr	Cymbi
3931	Ride Njz Cup St	Dr	Cymbi
3932	Ride Njz Cup L	Dr	Cymbi
3933	Ride Njz Cup R	Dr	Cymbi
3934	Ride Njz Cup RL	Dr	Cymbi
3935	Ride Cup1 St	Dr	Cymbi
3936	Ride Cup1 L	Dr	Cymbi
3937	Ride Cup1 R	Dr	Cymbi
3938	Ride Cup1 RL	Dr	Cymbi
3939	Ride Brush1 St	Dr	Cymbi
3940	Ride Brush1 L	Dr	Cymbi
3941	Ride Brush1 R	Dr	Cymbi
3942	Ride Brush1 RL	Dr	Cymbi
3943	Ride Brush2 St	Dr	Cymbi
3944	Ride Brush2 L	Dr	Cymbi
3945	Ride Brush2 R	Dr	Cymbi
3946	Ride Brush2 RL	Dr	Cymbi
3947	Ride Cup2 St	Dr	Cymbi
3948	Ride Cup2 L	Dr	Cymbi
3949	Ride Cup2 R	Dr	Cymbi
3950	Ride Cup2 RL	Dr	Cymbi

No.	Name	Main Category	Sub Category
3951	Ride Mono	Dr	Cymbi
3952	Ride Cup Mono	Dr	Cymbi
3953	Ride Cup Mono2	Dr	Cymbi
3954	China1 St	Dr	Cymbi
3955	China1 L	Dr	Cymbi
3956	China1 R	Dr	Cymbi
3957	China1 RL	Dr	Cymbi
3958	China2	Dr	Cymbi
3959	China3 St	Dr	Cymbi
3960	China3 L	Dr	Cymbi
3961	China3 R	Dr	Cymbi
3962	China3 RL	Dr	Cymbi
3963	Splash1 St	Dr	Cymbi
3964	Splash1 L	Dr	Cymbi
3965	Splash1 R	Dr	Cymbi
3966	Splash1 RL	Dr	Cymbi
3967	Splash2 St	Dr	Cymbi
3968	Splash2 L	Dr	Cymbi
3969	Splash2 R	Dr	Cymbi
3970	Splash2 RL	Dr	Cymbi
3971	Crash T9	Dr	Cymbi
3972	Crash T8	Dr	Cymbi
3973	Crash Syn	Dr	Cymbi
3974	Crash RX11	Dr	Cymbi
3975	Ride T9	Dr	Cymbi
3976	Ride RX11	Dr	Cymbi
3977	Reverse Cymbal	Dr	Cymbi

Performance List

USR1 (MSB=63, LSB=64)

Number	Performance Name	Perf. Category	Subcategory	
1	A01	Brachial Wobbling	Elect	Tekno
2	A02	Thawing	Elect	Chill
3	A03	Alternative Pop	Rock	Top40
4	A04	NuHop	R&B	HipHp
5	A05	Pumping Station MW	Elect	Trnce
6	A06	Double Dip the Funk	R&B	Funk
7	A07	Flipper AF1&2	Elect	D&B
8	A08	Movie Strings	SpLyr	Strng
9	A09	Recreation	Elect	Chill
10	A10	Lake Side	SpLyr	Piano
11	A11	Synth Power	Rock	Top40
12	A12	Swing Electric	Jazz	Swing
13	A13	Magnificent Mile	Elect	Tekno
14	A14	Groovestation Alpha	R&B	HipHp
15	A15	Andy Lucia	World	Latin
16	A16	Wonderful World	FX	Seq
17	B01	Scrap	Elect	Tekno
18	B02	Wide Screen	Elect	Chill
19	B03	Big Watches	Rock	Top40
20	B04	Sick!	R&B	HipHp
21	B05	Dance Party	Elect	Trnce
22	B06	BackStreet Jammer	R&B	Funk
23	B07	Deep Cover	Elect	D&B
24	B08	Oboe Soloist	SpLyr	WWind
25	B09	Evolve	Elect	Chill
26	B10	TX802 Beauty	SpLyr	Piano
27	B11	Dream Shuffle	Rock	Top40
28	B12	Thrust	Jazz	Smoth
29	B13	Wash Away	Elect	Tekno
30	B14	Zimbabwe	R&B	HipHp
31	B15	Multi-Cultural	World	Ethnc
32	B16	Vapor Grotto	FX	Soft
33	C01	Mince	Elect	Tekno
34	C02	Mystery Island	Elect	Chill
35	C03	Strummin'&Hummin'	Rock	Cntry
36	C04	Water Hopper	R&B	HipHp
37	C05	City Club	Elect	Trnce
38	C06	Midnight Drive	R&B	Funk
39	C07	Ground Waves AF1&2	Elect	House
40	C08	Winds & Strings	SpLyr	WWind
41	C09	Cold Space	Elect	Chill
42	C10	Yearn to see You	SpLyr	Synth
43	C11	Urban Shuffle	Rock	Clsic
44	C12	Film Noir	Jazz	Swing
45	C13	Rapid-Fire	Elect	Tekno
46	C14	Soul Walk	R&B	HipHp
47	C15	2 Guitars for Mrs R	World	Latin
48	C16	Harmony of Spirit	FX	Seq
49	D01	Robo-Hop	Elect	Tekno
50	D02	Epic Story	Elect	Chill
51	D03	Minor Mood	Rock	Balad
52	D04	Insect Cage	R&B	Modrn
53	D05	MainRoom Trance	Elect	Trnce
54	D06	Clavi Jam	R&B	Funk
55	D07	Hot House Funk	Elect	House
56	D08	Commander	SpLyr	Symph
57	D09	Mad Scientist	Elect	Chill
58	D10	Geiger Synth Bass	SpLyr	Bass
59	D11	80's Drummer	Rock	Top40
60	D12	Acid Club	Jazz	Club
61	D13	Elementz	Elect	Tekno
62	D14	Santur Funk	R&B	HipHp
63	D15	Afro Pop	World	Ethnc
64	D16	Sprinkler	FX	Soft

Number	Performance Name	Perf. Category	Subcategory	
65	E01	Nanovectors	Elect	Tekno
66	E02	Four Dimensions	Elect	Chill
67	E03	Auto Ballad	Rock	Balad
68	E04	We Were Kings	R&B	HipHp
69	E05	Body Slammer	Elect	Trnce
70	E06	Hold On a Minute	R&B	Clsic
71	E07	Pulsing Colors	Elect	House
72	E08	Dreamscape	SpLyr	Symph
73	E09	Psychedelic Dreamz	Elect	Chill
74	E10	Worship Center	SpLyr	Organ
75	E11	Rockin' the Country	Rock	Cntry
76	E12	Night Cruiser	Jazz	Smoth
77	E13	Angry Machines	Elect	Tekno
78	E14	Shredder	R&B	Modrn
79	E15	Two Hands of Latin	World	Latin
80	E16	Meeting Point	FX	Seq
81	F01	Giant Robots	Elect	Tekno
82	F02	Snake Charmer AF1&2	Elect	Chill
83	F03	Snake Eyes	Rock	Film
84	F04	Scissors	R&B	Modrn
85	F05	Strobe Lighterz	Elect	Trnce
86	F06	Funky Finger	R&B	Funk
87	F07	Planet Quaker	Elect	D&B
88	F08	Semi Finale	SpLyr	Symph
89	F09	Electric Sheep	Elect	Chill
90	F10	Gimme A Beat!	SpLyr	Synth
91	F11	Into The Sunset	Rock	Balad
92	F12	Sunset Horn	Jazz	Swing
93	F13	Yamatronic	Elect	Tekno
94	F14	Cairo	R&B	HipHp
95	F15	Bellydancer	World	Ethnc
96	F16	Arianes Nightwalk	FX	Seq
97	G01	What is he doing?	Elect	Tekno
98	G02	Doom Steps	Elect	Chill
99	G03	Open The Door	Rock	Clsic
100	G04	Electro Hop	R&B	HipHp
101	G05	Build em Up	Elect	Trnce
102	G06	Funk Jam	R&B	Funk
103	G07	Funk Nasty	Elect	House
104	G08	Harp/Piccolo	SpLyr	WWind
105	G09	Traumzeit	Elect	Chill
106	G10	Silent Spheres	SpLyr	Pad
107	G11	New Grunge	Rock	Hard
108	G12	Smooth It Over	Jazz	Smoth
109	G13	Electric Monkeys	Elect	Tekno
110	G14	Thunderous Wurli	R&B	HipHp
111	G15	Alma	World	Latin
112	G16	Abys of the Sea	FX	Seq
113	H01	Tollhouse	Elect	Tekno
114	H02	Auto Running	Elect	Chill
115	H03	Sunny Beaches	Rock	Clsic
116	H04	Poppin' Fresh	R&B	HipHp
117	H05	TranceFormer	Elect	Trnce
118	H06	Talk Show Band	R&B	Funk
119	H07	Confyoooshus	Elect	House
120	H08	The Birth Of Life	SpLyr	Symph
121	H09	Poppyhanger	Elect	Chill
122	H10	Stokholm Mafia	SpLyr	Synth
123	H11	Rule The Earth	Rock	Clsic
124	H12	Swingin' Organ Club	Jazz	Swing
125	H13	Electro Club	Elect	Tekno
126	H14	Deep Down Club	R&B	HipHp
127	H15	Hot Sauce	World	Latin
128	H16	ARP Duo	FX	Seq

USR2 (MSB=63, LSB=65)

Number	Performance Name	Category	Sub Category	
1	A01	Homeward Bound	Elect	Tekno
2	A02	Nightshadows	Elect	Chill
3	A03	Free Fall	Rock	Clsic
4	A04	Bubblicious	R&B	Modrn
5	A05	Subway Traxx Trigger	Elect	Trnce
6	A06	Soulful EP Player	R&B	Funk
7	A07	Dub City	Elect	D&B
8	A08	Strings/FrenchHorns	SpLyr	Symph
9	A09	White Sand Dub	Elect	Chill
10	A10	Angel Pad	SpLyr	Pad
11	A11	Austin City Blues	Rock	Clsic
12	A12	Clavi 70's 1	Jazz	JzFnk
13	A13	Atomic Bouncer	Elect	Tekno
14	A14	Slow and Low	R&B	HipHp
15	A15	Japan Festival	World	Ethnc
16	A16	Eighties Dreams	FX	Seq
17	B01	Glowing Socks	Elect	Tekno
18	B02	Chilltronika	Elect	Chill
19	B03	Love Her Crazyly	Rock	Clsic
20	B04	East Sider	R&B	HipHp
21	B05	Magic Spell	Elect	Trnce
22	B06	Funky Funny Afro	R&B	Funk
23	B07	Deep House 1	Elect	House
24	B08	Epic Orchestra	SpLyr	Symph
25	B09	Night Walk	Elect	Chill
26	B10	American Beauty	SpLyr	Piano
27	B11	Whole Lotta 8ths	Rock	Hard
28	B12	Jazz Lounge	Jazz	Swing
29	B13	Synthlines	Elect	Tekno
30	B14	Schmusin'	R&B	Modrn
31	B15	Pass the Naan	World	Ethnc
32	B16	Cloudy Bay	FX	Seq
33	C01	Magnetic Fields	Elect	Tekno
34	C02	Just Relax	Elect	Chill
35	C03	Drummers of Tokyo	Rock	Top40
36	C04	Don't Look!	R&B	Modrn
37	C05	Funfair	Elect	Trnce
38	C06	Worship	R&B	Clsic
39	C07	Buttoned Down	Elect	Chill
40	C08	Trumpet Concert	SpLyr	Brass
41	C09	Sneaking Diamonds	Elect	Chill
42	C10	2 Manuals	SpLyr	Organ
43	C11	Classic Shuffle Rock	Rock	Clsic
44	C12	Blues Organ Trio	Jazz	Swing
45	C13	Plutonium Freezer	Elect	Tekno
46	C14	Clubba Hop	R&B	HipHp
47	C15	Latin 4 Beginners	World	Latin
48	C16	Fountain	FX	Soft
49	D01	Lighthouse	Elect	Tekno
50	D02	Gentle Chillgroove	Elect	Chill
51	D03	Dark Continent	Rock	Clsic
52	D04	Hip Hop Orchestra	R&B	HipHp
53	D05	Cosmic Trance	Elect	Trnce
54	D06	Hot E.P. Noodles	R&B	Funk
55	D07	Inner Wind	Elect	Chill
56	D08	String Accompaniment	SpLyr	Piano
57	D09	Electric Mystery	Elect	Chill
58	D10	Lake Pad	SpLyr	Pad
59	D11	Andalucia Wind	Rock	Film
60	D12	Waltzing Quartet	Jazz	Swing
61	D13	Purple Stone	Elect	Tekno
62	D14	Yah-Yo-Jah	R&B	HipHp
63	D15	Piano Latino	World	Latin
64	D16	Ice Pizz	FX	Seq

Number	Performance Name	Category	Sub Category	
65	E01	Cool Box	Elect	Tekno
66	E02	Indian Xperience	Elect	Chill
67	E03	60s Border Town	Rock	Clsic
68	E04	Southern Rap Cat	R&B	HipHp
69	E05	Distorted Dreamz	Elect	Trnce
70	E06	Analog Power	R&B	Funk
71	E07	Semar Dub	Elect	Chill
72	E08	Yamaha Concerto	SpLyr	Symph
73	E09	Piano Electro	Elect	Chill
74	E10	Crying Scene	SpLyr	Pad
75	E11	Lava Rhythm	FX	Seq
76	E12	Bebop Trio	Jazz	Swing
77	E13	Pursuer	Elect	Tekno
78	E14	The Jammin Hood	R&B	HipHp
79	E15	Kogarashi	FX	Soft
80	E16	Sands of Time	FX	Soft
81	F01	DRY-Wash	Elect	Tekno
82	F02	Chilly Dreams	Elect	Chill
83	F03	Piano Boogie	Rock	Clsic
84	F04	Acid Shuffle	R&B	HipHp
85	F05	Sweet Peaches	Elect	Trnce
86	F06	GarageHopTrumpetBoi	R&B	Funk
87	F07	Second Breakfast	Elect	Chill
88	F08	Baroque Ensemble	SpLyr	Symph
89	F09	Wet Reflected Lights	Elect	Chill
90	F10	Full Monty	SpLyr	Organ
91	F11	Secret Film	FX	Seq
92	F12	Auto Funk 2	Jazz	JzFnk
93	F13	Welder	Elect	Tekno
94	F14	The Duece	R&B	HipHp
95	F15	Raging Waves	FX	Seq
96	F16	Space Gallery	FX	Soft
97	G01	Between the Lines	Elect	Tekno
98	G02	Fata Morgana	Elect	Chill
99	G03	Echo Park Rock	Rock	Balad
100	G04	Casbian Nights	R&B	HipHp
101	G05	Trance Vision	Elect	Trnce
102	G06	Organ Cruise	R&B	Funk
103	G07	Chilln Keys	Elect	Chill
104	G08	Fairy Tale	SpLyr	Strng
105	G09	Chill Performer	Elect	Chill
106	G10	Creepn Worm	SpLyr	Pad
107	G11	Java Winds	FX	Seq
108	G12	Late Show	Jazz	Swing
109	G13	Elektrik Arcade	Elect	Tekno
110	G14	4rims & a Microphone	R&B	HipHp
111	G15	Sample & Hold	FX	Seq
112	G16	Complex Beauty	FX	Soft
113	H01	Cool Breakz	Elect	Chill
114	H02	Bacteria	Elect	Chill
115	H03	Altered States	Rock	Hard
116	H04	Lurch	R&B	HipHp
117	H05	Chart Breaker	Elect	Trnce
118	H06	Funky Jump	R&B	Funk
119	H07	Peanut Butter Slices	Elect	Chill
120	H08	Fugue in D Minor	SpLyr	Symph
121	H09	Hand Mates	Elect	Chill
122	H10	Green Oasis	SpLyr	Pad
123	H11	Snow na Oto	FX	Seq
124	H12	Jazz Vibe	Jazz	Swing
125	H13	Heart Breakz	Elect	Trnce
126	H14	Neighborhood	R&B	HipHp
127	H15	Teatime	FX	Seq
128	H16	Falling Monks	FX	Soft

Master Assign List

Master No.	Master Name	Mode	Bank Name	Program Number
1	MOX Flash	Performance	User1	5
2	Natural Grand S6	Voice	Pre9	1
3	Arched Top	Voice	Pre9	35
4	The Jammin Hood	Performance	User2	78
5	Altered States	Performance	User2	115
6	Rule The Earth	Performance	User1	123
7	Tremolo Section	Voice	Pre9	53
8	[Demo Song 1]	Song	---	1
9	Jazz Lounge	Performance	User2	28
10	Trance Vision	Performance	User2	101
11	Buttoned Down	Performance	User2	39
12	Open The Door	Performance	User1	99
13	GarageHopTrumpetBoi	Performance	User2	86
14	Commander	Performance	User1	56
15	Fountain	Performance	User2	48
16	Lurch	Performance	User2	116
17	Piano Electro	Performance	User2	73
18	French Horn Section2	Voice	Pre9	63
19	Pass the Naan	Performance	User2	31
20	Big Watches	Performance	User1	19
21	Swingin' Organ Club	Performance	User1	124
22	Clavi Touch Wah	Voice	Pre9	8
23	Vx Dark Bars	Voice	Pre9	13
24	[Demo Song 2]	Song	---	2
25	Scrap	Performance	User1	17
26	Drummers of Tokyo	Performance	User2	35
27	Rapid-Fire	Performance	User1	45
28	Berlin Dreamz	Voice	Pre9	109
29	Indian Xperience	Performance	User2	66
30	Sands of Time	Performance	User2	80
31	Recreation	Performance	User1	9
32	Illest Hip Hop Kit	Voice	PRD	68
33	Pulsing Colors	Performance	User1	71
34	Natural Wurli	Voice	Pre1	45
35	On my Way to UK	Voice	Pre7	105
36	Sick!	Performance	User1	20
37	Synth Power	Performance	User1	11
38	Prec Amped AF1	Voice	Pre3	27
39	Cello Duo AF1	Voice	Pre4	6
40	[Demo Song 3]	Song	---	3
41	Scissors	Performance	User1	84
42	Psychedelic Dreamz	Performance	User1	73
43	Dance Party	Performance	User1	21
44	FullDraw/CVibrato	Voice	Pre1	104
45	Austin City Blues	Performance	User2	11
46	Dreamscape	Performance	User1	72
47	Harmony of Spirit	Performance	User1	48
48	Casbian Nights	Performance	User2	100
49	Water Hopper	Performance	User1	36
50	Full Tine	Voice	Pre1	52
51	Simple Arp	Voice	Pre8	8
52	Robo-Hop	Performance	User1	49
53	BackStreet Jammer	Performance	User1	22
54	Crunched Up 376	Voice	Pre2	111
55	Almighty	Voice	Pre4	12
56	[Demo Pattern 1]	Pattern	---	1
57	Film Noir	Performance	User1	44
58	Brachial Wobbling	Performance	User1	1
59	Snake Charmer AF1&2	Performance	User1	82
60	Dynamic Brass AF1&2	Voice	Pre4	97
61	Acid Club	Performance	User1	60
62	Trumpet Concert	Performance	User2	40
63	Flying Rhythm Bars	Voice	Pre1	128
64	Auto Ballad	Performance	User1	67

Master No.	Master Name	Mode	Bank Name	Program Number
65	Chilltronika	Performance	User2	18
66	CP 1979	Voice	Pre1	19
67	Vowel Pad	Voice	Pre6	27
68	Slow and Low	Performance	User2	14
69	Echo Park Rock	Performance	User2	99
70	Army Bass	Voice	Pre3	117
71	Sweet Oboe Legato	Voice	Pre5	21
72	[Demo Pattern 2]	Pattern	---	2
73	Swing Electric	Performance	User1	12
74	Heart Breakz	Performance	User2	125
75	Mince	Performance	User1	33
76	On Road AS1	Voice	Pre1	91
77	Talk Show Band	Performance	User1	118
78	Kogarashi	Performance	User2	79
79	Sample & Hold	Performance	User2	111
80	Multi-Cultural	Performance	User1	31
81	Arianes Nightwalk	Performance	User1	96
82	Vintage'74	Voice	Pre1	22
83	Dark Modulation Pad	Voice	Pre5	117
84	Yah-Yo-Jah	Performance	User2	62
85	Piano Boogie	Performance	User2	83
86	Mute & Slide Vel	Voice	Pre2	61
87	Violin Solo 2 AF1	Voice	Pre4	2
88	[Demo Pattern 3]	Pattern	---	3
89	Hold On a Minute	Performance	User1	70
90	Planet Quaker	Performance	User1	87
91	Electro Club	Performance	User1	125
92	Big Syn	Voice	Pre4	117
93	Into The Sunset	Performance	User1	91
94	Oboe Soloist	Performance	User1	24
95	Vapor Grotto	Performance	User1	32
96	Sunny Beaches	Performance	User1	115
97	Insect Cage	Performance	User1	52
98	1968	Voice	Pre1	18
99	Catching Wild Horses	Voice	Pre6	59
100	Epic Story	Performance	User1	50
101	Love Her Crazyly	Performance	User2	19
102	VoodooMan	Voice	Pre2	126
103	Velo Growl Legato	Voice	Pre5	10
104	Soulful EP Player	Performance	User2	6
105	Blues Organ Trio	Performance	User2	44
106	Funfair	Performance	User2	37
107	Magic Spell	Performance	User2	21
108	Panther	Voice	Pre1	119
109	Funky Finger	Performance	User1	86
110	Sprinkler	Performance	User1	64
111	Snow na Oto	Performance	User2	123
112	Bellydancer	Performance	User1	95
113	Dream Shuffle	Performance	User1	27
114	Contempo	Voice	Pre1	35
115	Pearls	Voice	Pre6	37
116	Poppin' Fresh	Performance	User1	116
117	Piano Latino	Performance	User2	63
118	Moon Bass	Voice	Pre3	57
119	Warm Big	Voice	Pre4	45
120	Funky Jump	Performance	User2	118
121	2 Guitars for Mrs R	Performance	User1	47
122	City Club	Performance	User1	37
123	Angry Machines	Performance	User1	77
124	Ob Soft	Voice	Pre4	127
125	Sneaking Diamonds	Performance	User2	41
126	Winds & Strings	Performance	User1	40
127	Thawing	Performance	User1	2
128	Hot E.P. Noodles	Performance	User2	54

Arpeggio Type List

General Voice types which are most suitable for the respective Arpeggio Types are listed in the "Voice Type" column. Among these, the ones in quotation marks are specific Voices actually provided on the MOXF6/MOXF8. Also, for Arpeggio Types belonging to the "Cntr" Category (pages 94 – 96), information about data (Control Change or Pitch Bend) programmed into the respective Arpeggio Types is listed in the "Voice Type" column. For Arpeggio Types programmed with Control Change data, the Control Change numbers are listed accordingly. For Arpeggio Types programmed with Pitch Bend data, Pitch Bend Range information is listed accordingly.

Main Category	Sub Category	ARP No.	ARP Name	Time Signature	Length	Original Tempo	Accent	Random SFX	Voice Type
ApKb	Rock	1	MA_70s Rock_ES	4/4	2	130			Acoustic Piano
ApKb	Rock	2	MB_70s Rock_ES	4/4	1	130			:
ApKb	Rock	3	MC_70s Rock	4/4	2	130			:
ApKb	Rock	4	MD_70s Rock	4/4	4	130			:
ApKb	Rock	5	FA_70s Rock	4/4	1	130			:
ApKb	Rock	6	FB_70s Rock_ES	4/4	1	130			:
ApKb	Rock	7	FC_70s Rock_ES	4/4	2	130			:
ApKb	Rock	8	MA_Rockn Pf	4/4	4	130			:
ApKb	Rock	9	MA_Rock & Roll_XS	4/4	4	172			:
ApKb	Rock	10	MB_Rock & Roll_XS	4/4	4	172			:
ApKb	Rock	11	MC_Rock & Roll_XS	4/4	4	172			:
ApKb	Rock	12	FA_Rock & Roll_XS	4/4	1	172			:
ApKb	Rock	13	FB_Rock & Roll_XS	4/4	1	172			:
ApKb	Rock	14	FC_Rock & Roll_XS	4/4	1	172			:
ApKb	Rock	15	BA_Rock & Roll_XS	4/4	1	172			:
ApKb	Rock	16	EA_Rock & Roll_XS	4/4	5	172			:
ApKb	Rock	17	EB_Rock & Roll_XS	4/4	6	172			:
ApKb	Rock	18	MA_ProgresRock2_XS	4/4	4	120			Electric Piano
ApKb	Rock	19	MB_ProgresRock2_XS	4/4	4	120			:
ApKb	Rock	20	MC_ProgresRock2_XS	4/4	4	120			:
ApKb	Rock	21	FA_ProgresRock2_XS	4/4	1	120			:
ApKb	Rock	22	FB_ProgresRock2_XS	4/4	1	120			:
ApKb	Rock	23	FC_ProgresRock2_XS	4/4	1	120			:
ApKb	Rock	24	BA_ProgresRock2_XS	4/4	1	120			:
ApKb	Rock	25	MA_ProgresRock2_ES	4/4	4	120			:
ApKb	Rock	26	MB_ProgresRock2_ES	4/4	4	120			:
ApKb	Rock	27	MC_ProgresRock2_ES	4/4	4	120			:
ApKb	Rock	28	FA_ProgresRock2_ES	4/4	1	120			:
ApKb	Rock	29	FB_ProgresRock2_ES	4/4	1	120			:
ApKb	Rock	30	FC_ProgresRock2_ES	4/4	1	120			:
ApKb	Rock	31	BA_ProgresRock2_ES	4/4	1	120			:
ApKb	PopRk	32	MA_Cool 8Beat_XS	4/4	2	100			:
ApKb	PopRk	33	MB_Cool 8Beat_XS	4/4	2	100			:
ApKb	PopRk	34	MC_Cool 8Beat_XS	4/4	2	100			:
ApKb	PopRk	35	FA_Cool 8Beat_XS	4/4	1	100			:
ApKb	PopRk	36	FB_Cool 8Beat_XS	4/4	1	100			:
ApKb	PopRk	37	FC_Cool 8Beat_XS	4/4	1	100			:
ApKb	PopRk	38	BA_Cool 8Beat_XS	4/4	1	100			:
ApKb	PopRk	39	EA_Cool 8Beat_XS	4/4	4	100			:
ApKb	PopRk	40	EB_Cool 8Beat_XS	4/4	4	100			:
ApKb	PopRk	41	MA_8Beat Basic_XS	4/4	4	120			:
ApKb	PopRk	42	MB_8Beat Basic_XS	4/4	4	120			:
ApKb	PopRk	43	MC_8Beat Basic_XS	4/4	4	120			:
ApKb	PopRk	44	FA_8Beat Basic_XS	4/4	1	120			:
ApKb	PopRk	45	FB_8Beat Basic_XS	4/4	1	120			:
ApKb	PopRk	46	FC_8Beat Basic_XS	4/4	1	120			:
ApKb	PopRk	47	BA_8Beat Basic_XS	4/4	1	120			:
ApKb	PopRk	48	MA_8Beat Basic_ES	4/4	4	120			:
ApKb	PopRk	49	MB_8Beat Basic_ES	4/4	4	120			:
ApKb	PopRk	50	MC_8Beat Basic_ES	4/4	4	120			:
ApKb	PopRk	51	FA_8Beat Basic_ES	4/4	1	120			:
ApKb	PopRk	52	FB_8Beat Basic_ES	4/4	1	120			:
ApKb	PopRk	53	FC_8Beat Basic_ES	4/4	1	120			:
ApKb	PopRk	54	BA_8Beat Basic_ES	4/4	1	120			:
ApKb	PopRk	55	MA_BritRockPop_XS	4/4	4	123			Acoustic Piano
ApKb	PopRk	56	MB_BritRockPop_XS	4/4	4	123			:
ApKb	PopRk	57	MC_BritRockPop_XS	4/4	4	123			:
ApKb	PopRk	58	FA_BritRockPop_XS	4/4	1	123			:
ApKb	PopRk	59	FB_BritRockPop_XS	4/4	1	123			:
ApKb	PopRk	60	FC_BritRockPop_XS	4/4	1	123			:
ApKb	PopRk	61	BA_BritRockPop_XS	4/4	1	123			:
ApKb	PopRk	62	EA_BritRockPop_XS	4/4	6	123			:
ApKb	PopRk	63	MA_60sVintagePop_XS	4/4	4	132			:
ApKb	PopRk	64	MB_60sVintagePop_XS	4/4	4	132			:
ApKb	PopRk	65	MC_60sVintagePop_XS	4/4	4	132			:
ApKb	PopRk	66	FA_60sVintagePop_XS	4/4	1	132			:
ApKb	PopRk	67	FB_60sVintagePop_XS	4/4	1	132			:
ApKb	PopRk	68	FC_60sVintagePop_XS	4/4	1	132			:
ApKb	PopRk	69	BA_60sVintagePop_XS	4/4	1	132			:
ApKb	PopRk	70	EA_60sVintagePop_XS	4/4	2	132			:
ApKb	PopRk	71	MA_60sChartSwing_XS	4/4	4	123			:
ApKb	PopRk	72	MB_60sChartSwing_XS	4/4	4	123			:
ApKb	PopRk	73	MC_60sChartSwing_XS	4/4	4	123			:
ApKb	PopRk	74	FA_60sChartSwing_XS	4/4	1	123			:
ApKb	PopRk	75	FB_60sChartSwing_XS	4/4	1	123			:
ApKb	PopRk	76	FC_60sChartSwing_XS	4/4	1	123			:
ApKb	PopRk	77	BA_60sChartSwing_XS	4/4	1	123			:
ApKb	PopRk	78	EA_60sChartSwing_XS	4/4	4	123			:
ApKb	PopRk	79	MA_16BeatBasic1_XS	4/4	4	90			Electric Piano
ApKb	PopRk	80	MB_16BeatBasic1_XS	4/4	4	90			:

Main Category	Sub Category	ARP No.	ARP Name	Time Signature	Length	Original Tempo	Accent	Random SFX	Voice Type
ApKb	PopRk	81	MC_16BeatBasic1_XS	4/4	4	90			Electric Piano
ApKb	PopRk	82	FA_16BeatBasic1_XS	4/4	1	90			:
ApKb	PopRk	83	FB_16BeatBasic1_XS	4/4	1	90			:
ApKb	PopRk	84	FC_16BeatBasic1_XS	4/4	1	90			:
ApKb	PopRk	85	BA_16BeatBasic1_XS	4/4	1	90			:
ApKb	PopRk	86	MA_16BeatBasic1_ES	4/4	4	90			:
ApKb	PopRk	87	MB_16BeatBasic1_ES	4/4	4	90			:
ApKb	PopRk	88	MC_16BeatBasic1_ES	4/4	4	90			:
ApKb	PopRk	89	FA_16BeatBasic1_ES	4/4	1	90			:
ApKb	PopRk	90	FB_16BeatBasic1_ES	4/4	1	90			:
ApKb	PopRk	91	FC_16BeatBasic1_ES	4/4	1	90			:
ApKb	PopRk	92	BA_16BeatBasic1_ES	4/4	1	90			:
ApKb	PopRk	93	MA_16BeatBasic2_XS	4/4	4	77			:
ApKb	PopRk	94	MB_16BeatBasic2_XS	4/4	4	77			:
ApKb	PopRk	95	MC_16BeatBasic2_XS	4/4	4	77			:
ApKb	PopRk	96	FA_16BeatBasic2_XS	4/4	1	77			:
ApKb	PopRk	97	FB_16BeatBasic2_XS	4/4	1	77			:
ApKb	PopRk	98	FC_16BeatBasic2_XS	4/4	1	77			:
ApKb	PopRk	99	BA_16BeatBasic2_XS	4/4	1	77			:
ApKb	PopRk	100	MA_16BeatBasic2_ES	4/4	4	77			:
ApKb	PopRk	101	MB_16BeatBasic2_ES	4/4	4	77			:
ApKb	PopRk	102	MC_16BeatBasic2_ES	4/4	4	77			:
ApKb	PopRk	103	FA_16BeatBasic2_ES	4/4	1	77			:
ApKb	PopRk	104	FB_16BeatBasic2_ES	4/4	1	77			:
ApKb	PopRk	105	FC_16BeatBasic2_ES	4/4	1	77			:
ApKb	PopRk	106	BA_16BeatBasic2_ES	4/4	1	77			:
ApKb	PopRk	107	MA_16Beat Pop 1_XS	4/4	4	103			:
ApKb	PopRk	108	MB_16Beat Pop 1_XS	4/4	4	103			:
ApKb	PopRk	109	MC_16Beat Pop 1_XS	4/4	4	103			:
ApKb	PopRk	110	FA_16Beat Pop 1_XS	4/4	1	103			:
ApKb	PopRk	111	FB_16Beat Pop 1_XS	4/4	1	103			:
ApKb	PopRk	112	FC_16Beat Pop 1_XS	4/4	1	103			:
ApKb	PopRk	113	BA_16Beat Pop 1_XS	4/4	1	103			:
ApKb	PopRk	114	MA_16Beat Pop 1_ES	4/4	4	103			:
ApKb	PopRk	115	MB_16Beat Pop 1_ES	4/4	4	103			:
ApKb	PopRk	116	MC_16Beat Pop 1_ES	4/4	4	103			:
ApKb	PopRk	117	FA_16Beat Pop 1_ES	4/4	1	103			:
ApKb	PopRk	118	FB_16Beat Pop 1_ES	4/4	1	103			:
ApKb	PopRk	119	FC_16Beat Pop 1_ES	4/4	1	103			:
ApKb	PopRk	120	BA_16Beat Pop 1_ES	4/4	1	103			:
ApKb	PopRk	121	MA_16Beat Pop 2_XS	4/4	4	94			Acoustic Piano
ApKb	PopRk	122	MB_16Beat Pop 2_XS	4/4	4	94			:
ApKb	PopRk	123	MC_16Beat Pop 2_XS	4/4	4	94			:
ApKb	PopRk	124	FA_16Beat Pop 2_XS	4/4	1	94			:
ApKb	PopRk	125	FB_16Beat Pop 2_XS	4/4	1	94			:
ApKb	PopRk	126	FC_16Beat Pop 2_XS	4/4	1	94			:
ApKb	PopRk	127	BA_16Beat Pop 2_XS	4/4	1	94			:
ApKb	PopRk	128	MA_16Beat Pop 2_ES	4/4	4	94			:
ApKb	PopRk	129	MB_16Beat Pop 2_ES	4/4	4	94			:
ApKb	PopRk	130	MC_16Beat Pop 2_ES	4/4	4	94			:
ApKb	PopRk	131	FA_16Beat Pop 2_ES	4/4	1	94			:
ApKb	PopRk	132	FB_16Beat Pop 2_ES	4/4	1	94			:
ApKb	PopRk	133	FC_16Beat Pop 2_ES	4/4	1	94			:
ApKb	PopRk	134	BA_16Beat Pop 2_ES	4/4	1	94			:
ApKb	PopRk	135	MC1_Piano Club	4/4	1	96			:
ApKb	PopRk	136	MD1_Piano Club	4/4	1	96			:
ApKb	PopRk	137	IA1_Piano Club	4/4	1	96			:
ApKb	PopRk	138	MD2_Piano Club	4/4	2	96			:
ApKb	PopRk	139	IA2_Piano Club	4/4	2	96			:
ApKb	PopRk	140	MC3_Piano Club	4/4	2	96			:
ApKb	PopRk	141	IA3_Piano Club	4/4	2	96			:
ApKb	PopRk	142	MB1_Analog Pop	4/4	2	93			Electric Piano
ApKb	PopRk	143	MC2_Analog Pop	4/4	2	93			:
ApKb	PopRk	144	IA2_Analog Pop	4/4	1	93			:
ApKb	PopRk	145	MA_6/8 Pop_XS	4/4	4	100			:
ApKb	PopRk	146	MB_6/8 Pop_XS	4/4	4	100			:
ApKb	PopRk	147	MC_6/8 Pop_XS	4/4	4	100			:
ApKb	PopRk	148	FA_6/8 Pop_XS	4/4	1	100			:
ApKb	PopRk	149	FB_6/8 Pop_XS	4/4	1	100			:
ApKb	PopRk	150	FC_6/8 Pop_XS	4/4	1	100			:
ApKb	PopRk	151	BA_6/8 Pop_XS	4/4	1	100			:
ApKb	PopRk	152	MA_6/8 Pop_ES	4/4	4	100			:
ApKb	PopRk	153	MB_6/8 Pop_ES	4/4	4	100			:
ApKb	PopRk	154	MC_6/8 Pop_ES	4/4	4	100			:
ApKb	PopRk	155	FA_6/8 Pop_ES	4/4	1	100			:
ApKb	PopRk	156	FB_6/8 Pop_ES	4/4	1	100			:
ApKb	PopRk	157	FC_6/8 Pop_ES	4/4	1	100			:
ApKb	PopRk	158	BA_6/8 Pop_ES	4/4	1	100			:
ApKb	Balad	159	MA_Unplugged 1_XS	4/4	4	120			Acoustic Piano
ApKb	Balad								

Arpeggio Type List

Main Category	Sub Category	ARP No.	ARP Name	Time Signature	Length	Original Tempo	Accent	Random SFX	Voice Type
ApKb	Balad	161	MC_Unplugged 1_XS	4/4	4	120			Acoustic Piano
ApKb	Balad	162	FA_Unplugged 1_XS	4/4	1	120			:
ApKb	Balad	163	FB_Unplugged 1_XS	4/4	1	120			:
ApKb	Balad	164	FC_Unplugged 1_XS	4/4	1	120			:
ApKb	Balad	165	BA_Unplugged 1_XS	4/4	1	120			:
ApKb	Balad	166	MA_Unplugged 3_XS	4/4	4	113			:
ApKb	Balad	167	MB_Unplugged 3_XS	4/4	4	113			:
ApKb	Balad	168	MC_Unplugged 3_XS	4/4	4	113			:
ApKb	Balad	169	FA_Unplugged 3_XS	4/4	1	113			:
ApKb	Balad	170	FB_Unplugged 3_XS	4/4	1	113			:
ApKb	Balad	171	FC_Unplugged 3_XS	4/4	1	113			:
ApKb	Balad	172	BA_Unplugged 3_XS	4/4	1	113			:
ApKb	Balad	173	MA_Unplugged 3_ES	4/4	4	113			:
ApKb	Balad	174	MB_Unplugged 3_ES	4/4	4	113			:
ApKb	Balad	175	MC_Unplugged 3_ES	4/4	4	113			:
ApKb	Balad	176	FA_Unplugged 3_ES	4/4	1	113			:
ApKb	Balad	177	FB_Unplugged 3_ES	4/4	1	113			:
ApKb	Balad	178	FC_Unplugged 3_ES	4/4	1	113			:
ApKb	Balad	179	BA_Unplugged 3_ES	4/4	1	113			:
ApKb	Balad	180	MA_EP Ballad_XS	4/4	2	60			Electric Piano
ApKb	Balad	181	MB_EP Ballad_XS	4/4	2	60			:
ApKb	Balad	182	MC_EP Ballad_XS	4/4	2	60			:
ApKb	Balad	183	FA_EP Ballad_XS	4/4	1	60			:
ApKb	Balad	184	FB_EP Ballad_XS	4/4	1	60			:
ApKb	Balad	185	FC_EP Ballad_XS	4/4	1	60			:
ApKb	Balad	186	BA_EP Ballad_XS	4/4	1	60			:
ApKb	Balad	187	EA_EP Ballad_XS	4/4	4	60			:
ApKb	Balad	188	EB_EP Ballad_XS	4/4	4	60			:
ApKb	Balad	189	MA1_8Beat Slow_XS	4/4	4	78			Acoustic Piano
ApKb	Balad	190	MB1_8Beat Slow_XS	4/4	4	78			:
ApKb	Balad	191	MC1_8Beat Slow_XS	4/4	4	78			:
ApKb	Balad	192	FA1_8Beat Slow_XS	4/4	1	78			:
ApKb	Balad	193	FB1_8Beat Slow_XS	4/4	1	78			:
ApKb	Balad	194	FC1_8Beat Slow_XS	4/4	1	78			:
ApKb	Balad	195	BA1_8Beat Slow_XS	4/4	1	78			:
ApKb	Balad	196	MA1_8Beat Slow_ES	4/4	4	78			:
ApKb	Balad	197	MB1_8Beat Slow_ES	4/4	4	78			:
ApKb	Balad	198	MC1_8Beat Slow_ES	4/4	4	78			:
ApKb	Balad	199	FA1_8Beat Slow_ES	4/4	1	78			:
ApKb	Balad	200	FB1_8Beat Slow_ES	4/4	1	78			:
ApKb	Balad	201	FC1_8Beat Slow_ES	4/4	1	78			:
ApKb	Balad	202	BA1_8Beat Slow_ES	4/4	1	78			:
ApKb	Balad	203	MA2_8Beat Slow_XS	4/4	4	78			Electric Piano
ApKb	Balad	204	MB2_8Beat Slow_XS	4/4	4	78			:
ApKb	Balad	205	MC2_8Beat Slow_XS	4/4	4	78			:
ApKb	Balad	206	FA2_8Beat Slow_XS	4/4	1	78			:
ApKb	Balad	207	FB2_8Beat Slow_XS	4/4	1	78			:
ApKb	Balad	208	FC2_8Beat Slow_XS	4/4	1	78			:
ApKb	Balad	209	BA2_8Beat Slow_XS	4/4	1	78			:
ApKb	Balad	210	MA2_8Beat Slow_ES	4/4	4	78			:
ApKb	Balad	211	MB2_8Beat Slow_ES	4/4	4	78			:
ApKb	Balad	212	MC2_8Beat Slow_ES	4/4	4	78			:
ApKb	Balad	213	FA2_8Beat Slow_ES	4/4	1	78			:
ApKb	Balad	214	FB2_8Beat Slow_ES	4/4	1	78			:
ApKb	Balad	215	FC2_8Beat Slow_ES	4/4	1	78			:
ApKb	Balad	216	BA2_8Beat Slow_ES	4/4	1	78			:
ApKb	Balad	217	MA_8Beat Soft_XS	4/4	4	100			:
ApKb	Balad	218	MB_8Beat Soft_XS	4/4	4	100			:
ApKb	Balad	219	MC_8Beat Soft_XS	4/4	4	100			:
ApKb	Balad	220	FA_8Beat Soft_XS	4/4	1	100			:
ApKb	Balad	221	FB_8Beat Soft_XS	4/4	1	100			:
ApKb	Balad	222	FC_8Beat Soft_XS	4/4	1	100			:
ApKb	Balad	223	BA_8Beat Soft_XS	4/4	1	100			:
ApKb	Balad	224	MA_8Beat Soft_ES	4/4	4	100			:
ApKb	Balad	225	MB_8Beat Soft_ES	4/4	4	100			:
ApKb	Balad	226	MC_8Beat Soft_ES	4/4	4	100			:
ApKb	Balad	227	FA_8Beat Soft_ES	4/4	1	100			:
ApKb	Balad	228	FB_8Beat Soft_ES	4/4	1	100			:
ApKb	Balad	229	FC_8Beat Soft_ES	4/4	1	100			:
ApKb	Balad	230	BA_8Beat Soft_ES	4/4	1	100			:
ApKb	Balad	231	MA_Slowfeel	4/4	1	74			:
ApKb	Balad	232	MB_Slowfeel	4/4	1	74			:
ApKb	Balad	233	MC_Slowfeel	4/4	1	74			:
ApKb	Balad	234	MD_Slowfeel	4/4	1	74			:
ApKb	Balad	235	FB_Slowfeel	4/4	1	74			:
ApKb	Balad	236	FC_Slowfeel	4/4	1	74			:
ApKb	Balad	237	MA_16Bt Ballad1_XS	4/4	4	75			:
ApKb	Balad	238	MB_16Bt Ballad1_XS	4/4	4	75			:
ApKb	Balad	239	MC_16Bt Ballad1_XS	4/4	4	75			:
ApKb	Balad	240	FA_16Bt Ballad1_XS	4/4	1	75			:
ApKb	Balad	241	FB_16Bt Ballad1_XS	4/4	1	75			:
ApKb	Balad	242	FC_16Bt Ballad1_XS	4/4	1	75			:
ApKb	Balad	243	BA_16Bt Ballad1_XS	4/4	1	75			:

Main Category	Sub Category	ARP No.	ARP Name	Time Signature	Length	Original Tempo	Accent	Random SFX	Voice Type
ApKb	Balad	244	MA_16Bt Ballad1_ES	4/4	4	75			Electric Piano
ApKb	Balad	245	MB_16Bt Ballad1_ES	4/4	4	75			:
ApKb	Balad	246	MC_16Bt Ballad1_ES	4/4	4	75			:
ApKb	Balad	247	FA_16Bt Ballad1_ES	4/4	1	75			:
ApKb	Balad	248	FB_16Bt Ballad1_ES	4/4	1	75			:
ApKb	Balad	249	FC_16Bt Ballad1_ES	4/4	1	75			:
ApKb	Balad	250	BA_16Bt Ballad1_ES	4/4	1	75			:
ApKb	HipHip	251	MA_Bklyn	4/4	2	89			Acoustic Piano
ApKb	HipHip	252	MB_Bklyn	4/4	2	89			:
ApKb	HipHip	253	MC_Bklyn_ES	4/4	2	89			:
ApKb	HipHip	254	MD_Bklyn	4/4	2	89			:
ApKb	HipHip	255	ME_Bklyn_ES	4/4	2	89			:
ApKb	HipHip	256	MA_HipHopEpic	4/4	2	85			:
ApKb	HipHip	257	MB_HipHopEpic_ES	4/4	2	85			:
ApKb	HipHip	258	MA_New Hip Hop_XS	4/4	2	85			Electric Piano
ApKb	HipHip	259	MB_New Hip Hop_XS	4/4	2	85			:
ApKb	HipHip	260	MC_New Hip Hop_XS	4/4	2	85			:
ApKb	HipHip	261	FA_New Hip Hop_XS	4/4	1	85			:
ApKb	HipHip	262	FB_New Hip Hop_XS	4/4	1	85			:
ApKb	HipHip	263	FC_New Hip Hop_XS	4/4	1	85			:
ApKb	HipHip	264	BA_New Hip Hop_XS	4/4	1	85			:
ApKb	HipHip	265	EA_New Hip Hop_XS	4/4	3	85			:
ApKb	HipHip	266	EB_New Hip Hop_XS	4/4	3	85			:
ApKb	HipHip	267	MA1_Hip Hop 1_ES	4/4	2	105			:
ApKb	HipHip	268	MB1_Hip Hop 1_ES	4/4	2	105			:
ApKb	HipHip	269	MC1_Hip Hop 1_ES	4/4	2	105			:
ApKb	HipHip	270	FB1_Hip Hop 1_ES	4/4	1	105			:
ApKb	HipHip	271	MA2_Hip Hop 1_ES	4/4	2	105			Harpischord
ApKb	HipHip	272	MB2_Hip Hop 1_ES	4/4	2	105			:
ApKb	HipHip	273	MC2_Hip Hop 1_ES	4/4	2	105			:
ApKb	HipHip	274	FB2_Hip Hop 1_ES	4/4	1	105			:
ApKb	HipHip	275	FC_Hip Hop 2	4/4	2	94			Electric Piano
ApKb	HipHip	276	MA_Hip Reggae_XS	4/4	4	92			Acoustic Piano
ApKb	HipHip	277	MB_Hip Reggae_XS	4/4	4	92			:
ApKb	HipHip	278	MC_Hip Reggae_XS	4/4	4	92			:
ApKb	HipHip	279	FB_Hip Reggae_XS	4/4	1	92			:
ApKb	HipHip	280	MA1_ClasicHipHop	4/4	1	90			:
ApKb	HipHip	281	MB1_ClasicHipHop	4/4	1	90			:
ApKb	HipHip	282	IA2_ClasicHipHop_ES	4/4	2	90			Electric Piano
ApKb	R&B-M	283	MA_Slow & Easy_XS	4/4	4	72			:
ApKb	R&B-M	284	MB_Slow & Easy_XS	4/4	4	72			:
ApKb	R&B-M	285	MC_Slow & Easy_XS	4/4	4	72			:
ApKb	R&B-M	286	FA_Slow & Easy_XS	4/4	1	72			:
ApKb	R&B-M	287	FB_Slow & Easy_XS	4/4	1	72			:
ApKb	R&B-M	288	FC_Slow & Easy_XS	4/4	1	72			:
ApKb	R&B-M	289	BA_Slow & Easy_XS	4/4	1	72			:
ApKb	R&B-M	290	EA_Slow & Easy_XS	4/4	3	72			:
ApKb	R&B-M	291	EB_Slow & Easy_XS	4/4	4	72			:
ApKb	R&B-M	292	MA_Pop Shuffle1_XS	4/4	4	94			Acoustic Piano
ApKb	R&B-M	293	MB_Pop Shuffle1_XS	4/4	4	94			:
ApKb	R&B-M	294	MC_Pop Shuffle1_XS	4/4	4	94			:
ApKb	R&B-M	295	FA_Pop Shuffle1_XS	4/4	1	94			:
ApKb	R&B-M	296	FB_Pop Shuffle1_XS	4/4	1	94			:
ApKb	R&B-M	297	FC_Pop Shuffle1_XS	4/4	1	94			:
ApKb	R&B-M	298	BA_Pop Shuffle1_XS	4/4	1	94			:
ApKb	R&B-M	299	MA_Pop Shuffle1_ES	4/4	4	94			:
ApKb	R&B-M	300	MB_Pop Shuffle1_ES	4/4	4	94			:
ApKb	R&B-M	301	MC_Pop Shuffle1_ES	4/4	4	94			:
ApKb	R&B-M	302	FA_Pop Shuffle1_ES	4/4	1	94			:
ApKb	R&B-M	303	FB_Pop Shuffle1_ES	4/4	1	94			:
ApKb	R&B-M	304	FC_Pop Shuffle1_ES	4/4	1	94			:
ApKb	R&B-M	305	BA_Pop Shuffle1_ES	4/4	1	94			:
ApKb	R&B-M	306	MA_Pop Shuffle2_XS	4/4	4	80			:
ApKb	R&B-M	307	MB_Pop Shuffle2_XS	4/4	4	80			:
ApKb	R&B-M	308	MC_Pop Shuffle2_XS	4/4	4	80			:
ApKb	R&B-M	309	FA_Pop Shuffle2_XS	4/4	1	80			:
ApKb	R&B-M	310	FB_Pop Shuffle2_XS	4/4	1	80			:
ApKb	R&B-M	311	FC_Pop Shuffle2_XS	4/4	1	80			:
ApKb	R&B-M	312	BA_Pop Shuffle2_XS	4/4	1	80			:
ApKb	R&B-M	313	MA_Pop Shuffle2_ES	4/4	4	80			:
ApKb	R&B-M	314	MB_Pop Shuffle2_ES	4/4	4	80			:
ApKb	R&B-M	315	MC_Pop Shuffle2_ES	4/4	4	80			:
ApKb	R&B-M	316	FA_Pop Shuffle2_ES	4/4	1	80			:
ApKb	R&B-M	317	FB_Pop Shuffle2_ES	4/4	1	80			:
ApKb	R&B-M	318	FC_Pop Shuffle2_ES	4/4	1	80			:
ApKb	R&B-M	319	BA_Pop Shuffle2_ES	4/4	1	80			:
ApKb	R&B-M	320	MA_R&B Disco	4/4	2	110			Electric Piano
ApKb	R&B-M	321	MD_R&B Disco	4/4	2	110			:
ApKb	R&B-M	322	FB_R&B Disco	4/4	1	110			:
ApKb	R&B-M	323	FC_R&B Disco	4/4	2				

Arpeggio Type List

Main Category	Sub Category	ARP No.	ARP Name	Time Signature	Length	Original Tempo	Accent	Random SFX	Voice Type
ApKb	R&B-M	327	FA_ChartPop1_XS	4/4	1	92			Electric Piano
ApKb	R&B-M	328	FB_ChartPop1_XS	4/4	1	92			:
ApKb	R&B-M	329	FC_ChartPop1_XS	4/4	1	92			:
ApKb	R&B-M	330	BA_ChartPop1_XS	4/4	1	92			:
ApKb	R&B-M	331	EA_ChartPop1_XS	4/4	3	92			:
ApKb	R&B-M	332	EB_ChartPop1_XS	4/4	3	92			:
ApKb	R&B-M	333	MA_H-R&B Pop_XS	4/4	4	140			:
ApKb	R&B-M	334	MB_H-R&B Pop_XS	4/4	4	140			:
ApKb	R&B-M	335	MC_H-R&B Pop_XS	4/4	4	140			:
ApKb	R&B-M	336	FA_H-R&B Pop_XS	4/4	1	140			:
ApKb	R&B-M	337	FB_H-R&B Pop_XS	4/4	1	140			:
ApKb	R&B-M	338	FC_H-R&B Pop_XS	4/4	1	140			:
ApKb	R&B-M	339	BA_H-R&B Pop_XS	4/4	1	140			:
ApKb	R&B-M	340	MA_J-R&B Pop_XS	4/4	4	100			:
ApKb	R&B-M	341	MB_J-R&B Pop_XS	4/4	4	100			:
ApKb	R&B-M	342	MC_J-R&B Pop_XS	4/4	4	100			:
ApKb	R&B-M	343	FA_J-R&B Pop_XS	4/4	1	100			:
ApKb	R&B-M	344	FB_J-R&B Pop_XS	4/4	1	100			:
ApKb	R&B-M	345	FC_J-R&B Pop_XS	4/4	1	100			:
ApKb	R&B-M	346	MA_R&B Ballad 1_XS	4/4	4	70			:
ApKb	R&B-M	347	MB_R&B Ballad 1_XS	4/4	4	70			:
ApKb	R&B-M	348	MC_R&B Ballad 1_XS	4/4	4	70			:
ApKb	R&B-M	349	FA_R&B Ballad 1_XS	4/4	1	70			:
ApKb	R&B-M	350	FB_R&B Ballad 1_XS	4/4	1	70			:
ApKb	R&B-M	351	FC_R&B Ballad 1_XS	4/4	1	70			:
ApKb	R&B-M	352	BA_R&B Ballad 1_XS	4/4	1	70			:
ApKb	R&B-M	353	MA_R&B Ballad 3_XS	4/4	4	113			:
ApKb	R&B-M	354	MB_R&B Ballad 3_XS	4/4	4	113			:
ApKb	R&B-M	355	MC_R&B Ballad 3_XS	4/4	4	113			:
ApKb	R&B-M	356	FA_R&B Ballad 3_XS	4/4	1	113			:
ApKb	R&B-M	357	FB_R&B Ballad 3_XS	4/4	1	113			:
ApKb	R&B-M	358	FC_R&B Ballad 3_XS	4/4	1	113			:
ApKb	R&B-M	359	MA_Ballad EP1	4/4	2	74			:
ApKb	R&B-M	360	MA_Ballad EP2	4/4	2	74			:
ApKb	R&B-M	361	MA_Ballad EP3	4/4	2	74			:
ApKb	R&B-M	362	MA_Swing EP	4/4	1	101			:
ApKb	R&B-M	363	MA_EP Chords	4/4	2	101			:
ApKb	R&B-M	364	MA1_6/8 R&B	4/4	2	61			Acoustic Piano
ApKb	R&B-M	365	MB1_6/8 R&B	4/4	2	61			:
ApKb	R&B-M	366	MC1_6/8 R&B	4/4	2	61			:
ApKb	R&B-M	367	MA1_6/8 R&B	4/4	2	61			:
ApKb	R&B-M	368	IA1_6/8 R&B	4/4	2	61			:
ApKb	R&B-M	369	FA1_6/8 R&B	4/4	1	61			:
ApKb	R&B-M	370	FB1_6/8 R&B	4/4	1	61			:
ApKb	R&B-M	371	MA2_6/8 R&B	4/4	2	61			Electric Piano
ApKb	R&B-M	372	MB2_6/8 R&B	4/4	2	61			:
ApKb	R&B-M	373	MC2_6/8 R&B	4/4	2	61			:
ApKb	R&B-M	374	MD2_6/8 R&B	4/4	2	61			:
ApKb	R&B-M	375	IA2_6/8 R&B	4/4	2	61			:
ApKb	R&B-M	376	FA2_6/8 R&B_ES	4/4	1	61			:
ApKb	R&B-M	377	FB2_6/8 R&B_ES	4/4	1	61			:
ApKb	R&B-M	378	MB_Smooth 1	4/4	2	115			:
ApKb	R&B-M	379	MC_Smooth 1	4/4	2	115			:
ApKb	R&B-M	380	MA_New Gospel	4/4	2	90			:
ApKb	R&B-M	381	MB_New Gospel	4/4	2	90			:
ApKb	R&B-M	382	MC_New Gospel	4/4	2	90			:
ApKb	R&B-M	383	MD_New Gospel	4/4	2	90			:
ApKb	R&B-M	384	FA_New Gospel	4/4	1	90			:
ApKb	R&B-M	385	FC_New Gospel	4/4	2	90			:
ApKb	R&B-C	386	MA_Philadelphia_XS	4/4	2	100			Acoustic Piano
ApKb	R&B-C	387	MB_Philadelphia_XS	4/4	2	100			:
ApKb	R&B-C	388	MC_Philadelphia_XS	4/4	2	100			:
ApKb	R&B-C	389	FA_Philadelphia_XS	4/4	1	100			:
ApKb	R&B-C	390	FB_Philadelphia_XS	4/4	1	100			:
ApKb	R&B-C	391	FC_Philadelphia_XS	4/4	1	100			:
ApKb	R&B-C	392	BA_Philadelphia_XS	4/4	1	100			:
ApKb	R&B-C	393	EA_Philadelphia_XS	4/4	4	100			:
ApKb	R&B-C	394	EB_Philadelphia_XS	4/4	3	100			:
ApKb	R&B-C	395	MA_Soul 2_ES	4/4	2	120			:
ApKb	R&B-C	396	MB_Soul 2_ES	4/4	1	120			:
ApKb	R&B-C	397	MC_Soul 2_ES	4/4	4	120			:
ApKb	R&B-C	398	MD_Soul 2_ES	4/4	4	120			:
ApKb	R&B-C	399	FC_Soul 2_ES	4/4	4	120			:
ApKb	R&B-C	400	MA_Frankly Soul_XS	4/4	4	120			:
ApKb	R&B-C	401	MB_Frankly Soul_XS	4/4	4	120			:
ApKb	R&B-C	402	MC_Frankly Soul_XS	4/4	4	120			:
ApKb	R&B-C	403	FA_Frankly Soul_XS	4/4	1	120			:
ApKb	R&B-C	404	FB_Frankly Soul_XS	4/4	1	120			:
ApKb	R&B-C	405	FC_Frankly Soul_XS	4/4	1	120			:
ApKb	R&B-C	406	BA_Frankly Soul_XS	4/4	1	120			:
ApKb	R&B-C	407	EA_Frankly Soul_XS	4/4	3	120			:
ApKb	R&B-C	408	EB_Frankly Soul_XS	4/4	4	120			:
ApKb	R&B-C	409	MA_Soul Beat_XS	4/4	4	124			:

Main Category	Sub Category	ARP No.	ARP Name	Time Signature	Length	Original Tempo	Accent	Random SFX	Voice Type
ApKb	R&B-C	410	MB_Soul Beat_XS	4/4	4	124			Acoustic Piano
ApKb	R&B-C	411	MC_Soul Beat_XS	4/4	4	124			:
ApKb	R&B-C	412	FA_Soul Beat_XS	4/4	1	124			:
ApKb	R&B-C	413	FB_Soul Beat_XS	4/4	1	124			:
ApKb	R&B-C	414	FC_Soul Beat_XS	4/4	1	124			:
ApKb	R&B-C	415	BA_Soul Beat_XS	4/4	1	124			:
ApKb	R&B-C	416	EA_Soul Beat_XS	4/4	3	123			:
ApKb	R&B-C	417	EB_Soul Beat_XS	4/4	3	123			:
ApKb	R&B-C	418	MA_Soul Shuffle_XS	4/4	4	98			Electric Piano
ApKb	R&B-C	419	MB_Soul Shuffle_XS	4/4	4	98			:
ApKb	R&B-C	420	MC_Soul Shuffle_XS	4/4	4	98			:
ApKb	R&B-C	421	FA_Soul Shuffle_XS	4/4	1	98			:
ApKb	R&B-C	422	FB_Soul Shuffle_XS	4/4	1	98			:
ApKb	R&B-C	423	FC_Soul Shuffle_XS	4/4	1	98			:
ApKb	R&B-C	424	BA_Soul Shuffle_XS	4/4	1	98			:
ApKb	R&B-C	425	EA_Soul Shuffle_XS	4/4	3	98			:
ApKb	R&B-C	426	EB_Soul Shuffle_XS	4/4	3	98			:
ApKb	R&B-C	427	MA_Soul Swing_XS	4/4	4	124			Acoustic Piano
ApKb	R&B-C	428	MB_Soul Swing_XS	4/4	4	124			:
ApKb	R&B-C	429	MC_Soul Swing_XS	4/4	4	124			:
ApKb	R&B-C	430	FA_Soul Swing_XS	4/4	1	124			:
ApKb	R&B-C	431	FB_Soul Swing_XS	4/4	1	124			:
ApKb	R&B-C	432	FC_Soul Swing_XS	4/4	1	124			:
ApKb	R&B-C	433	BA_Soul Swing_XS	4/4	1	124			:
ApKb	R&B-C	434	EA_Soul Swing_XS	4/4	3	123			:
ApKb	R&B-C	435	EB_Soul Swing_XS	4/4	5	123			:
ApKb	R&B-C	436	MA_GospelBrothr_XS	4/4	4	108			:
ApKb	R&B-C	437	MB_GospelBrothr_XS	4/4	4	108			:
ApKb	R&B-C	438	MC_GospelBrothr_XS	4/4	4	108			:
ApKb	R&B-C	439	FA_GospelBrothr_XS	4/4	1	108			:
ApKb	R&B-C	440	FB_GospelBrothr_XS	4/4	1	108			:
ApKb	R&B-C	441	FC_GospelBrothr_XS	4/4	1	108			:
ApKb	R&B-C	442	BA_GospelBrothr_XS	4/4	1	108			:
ApKb	R&B-C	443	EA_GospelBrothr_XS	4/4	4	108			:
ApKb	R&B-C	444	EB_GospelBrothr_XS	4/4	3	108			:
ApKb	Funk	445	MA_Funk 1_XS	4/4	8	104			Electric Piano
ApKb	Funk	446	MB_Funk 1_XS	4/4	8	104			:
ApKb	Funk	447	MC_Funk 1_XS	4/4	8	104			:
ApKb	Funk	448	FA_Funk 1_XS	4/4	1	104			:
ApKb	Funk	449	FB_Funk 1_XS	4/4	1	104			:
ApKb	Funk	450	FC_Funk 1_XS	4/4	1	104			:
ApKb	Funk	451	BA_Funk 1_XS	4/4	1	104			:
ApKb	Funk	452	EA_Funk 1_XS	4/4	9	104			:
ApKb	Funk	453	EB_Funk 1_XS	4/4	4	104			:
ApKb	Funk	454	MD_Cool Funk	4/4	2	96			:
ApKb	Funk	455	IA_Cool Funk	4/4	2	96			:
ApKb	Funk	456	FA_Cool Funk	4/4	1	96			:
ApKb	Funk	457	FB_Cool Funk	4/4	1	96			:
ApKb	Funk	458	MA_Jazz Pop_XS	4/4	2	102			:
ApKb	Funk	459	MB_Jazz Pop_XS	4/4	2	102			:
ApKb	Funk	460	MC_Jazz Pop_XS	4/4	2	102			:
ApKb	Funk	461	FA_Jazz Pop_XS	4/4	1	102			:
ApKb	Funk	462	FB_Jazz Pop_XS	4/4	1	102			:
ApKb	Funk	463	FC_Jazz Pop_XS	4/4	1	102			:
ApKb	Funk	464	BA_Jazz Pop_XS	4/4	1	102			:
ApKb	Funk	465	MA_Club Jazz 1_XS	4/4	4	125			Acoustic Piano
ApKb	Funk	466	MB_Club Jazz 1_XS	4/4	4	125			:
ApKb	Funk	467	MC_Club Jazz 1_XS	4/4	4	125			:
ApKb	Funk	468	FA_Club Jazz 1_XS	4/4	1	125			:
ApKb	Funk	469	FB_Club Jazz 1_XS	4/4	1	125			:
ApKb	Funk	470	FC_Club Jazz 1_XS	4/4	1	125			:
ApKb	Funk	471	BA_Club Jazz 1_XS	4/4	1	125			:
ApKb	Funk	472	MA_Club Jazz 1_ES	4/4	4	125			:
ApKb	Funk	473	MB_Club Jazz 1_ES	4/4	4	125			:
ApKb	Funk	474	MC_Club Jazz 1_ES	4/4	4	125			:
ApKb	Funk	475	FA_Club Jazz 1_ES	4/4	1	125			:
ApKb	Funk	476	FB_Club Jazz 1_ES	4/4	1	125			:
ApKb	Funk	477	FC_Club Jazz 1_ES	4/4	1	125			:
ApKb	Funk	478	BA_Club Jazz 1_ES	4/4	1	125			:
ApKb	Funk	479	MA_Club Jazz 2_XS	4/4	4	92			:
ApKb	Funk	480	MB_Club Jazz 2_XS	4/4	4	92			:
ApKb	Funk	481	MC_Club Jazz 2_XS	4/4	4	92			:
ApKb	Funk	482	FA_Club Jazz 2_XS	4/4	1	92			:
ApKb	Funk	483	FB_Club Jazz 2_XS	4/4	1	92			:
ApKb	Funk	484	FC_Club Jazz 2_XS	4/4	1	92			:
ApKb	Funk	485	BA_Club Jazz 2_XS	4/4	1	92			:
ApKb	Funk	486	MA_Club Jazz 2_ES	4/4	4	92			:
ApKb	Funk	487							

Arpeggio Type List

Main Category	Sub Category	ARP No.	ARP Name	Time Signature	Length	Original Tempo	Accent	Random SFX	Voice Type
ApKb	Funk	493	MA_Gospel Funk_XS	4/4	4	106			Acoustic Piano
ApKb	Funk	494	MB_Gospel Funk_XS	4/4	4	106			:
ApKb	Funk	495	MC_Gospel Funk_XS	4/4	4	106			:
ApKb	Funk	496	FA_Gospel Funk_XS	4/4	1	106			:
ApKb	Funk	497	FB_Gospel Funk_XS	4/4	1	106			:
ApKb	Funk	498	FC_Gospel Funk_XS	4/4	1	106			:
ApKb	Funk	499	BA_Gospel Funk_XS	4/4	1	106			:
ApKb	Funk	500	EA_Gospel Funk_XS	4/4	4	106			:
ApKb	Funk	501	EB_Gospel Funk_XS	4/4	3	106			:
ApKb	Funk	502	MA_Funk Disco_XS	4/4	2	126			Electric Piano
ApKb	Funk	503	MB_Funk Disco_XS	4/4	2	126			:
ApKb	Funk	504	MC_Funk Disco_XS	4/4	2	126			:
ApKb	Funk	505	FA_Funk Disco_XS	4/4	1	126			:
ApKb	Funk	506	FB_Funk Disco_XS	4/4	1	126			:
ApKb	Funk	507	FC_Funk Disco_XS	4/4	1	126			:
ApKb	Funk	508	BA_Funk Disco_XS	4/4	1	126			:
ApKb	Funk	509	EA_Funk Disco_XS	4/4	4	126			:
ApKb	Funk	510	EB_Funk Disco_XS	4/4	3	126			:
ApKb	Funk	511	MA_70sDiscoFunk_XS	4/4	4	112			Acoustic Piano
ApKb	Funk	512	MB_70sDiscoFunk_XS	4/4	4	112			:
ApKb	Funk	513	MC_70sDiscoFunk_XS	4/4	4	112			:
ApKb	Funk	514	FA_70sDiscoFunk_XS	4/4	1	112			:
ApKb	Funk	515	FB_70sDiscoFunk_XS	4/4	1	112			:
ApKb	Funk	516	FC_70sDiscoFunk_XS	4/4	1	112			:
ApKb	Funk	517	BA_70sDiscoFunk_XS	4/4	1	112			:
ApKb	Funk	518	EA_70sDiscoFunk_XS	4/4	4	112			:
ApKb	Funk	519	EB_70sDiscoFunk_XS	4/4	3	112			:
ApKb	Funk	520	MA_Clavi1	4/4	1	110			Clavi
ApKb	Funk	521	MA_Clavi2	4/4	1	110			:
ApKb	Funk	522	MA_Clavi3	4/4	1	110			:
ApKb	Funk	523	MA_Clavi4	4/4	1	124			:
ApKb	Funk	524	MA_Clavi5	4/4	1	124			:
ApKb	Funk	525	MA_Clavi6	4/4	1	124			:
ApKb	Funk	526	MA_Clavi7	4/4	1	124			:
ApKb	Funk	527	MA_Super Clavi	4/4	4	101			:
ApKb	Funk	528	MA_Touch Clavi	4/4	1	101			:
ApKb	House	529	MA_Disco House_XS	4/4	4	126			Electric Piano
ApKb	House	530	MB_Disco House_XS	4/4	4	126			:
ApKb	House	531	MC_Disco House_XS	4/4	4	126			:
ApKb	House	532	FA_Disco House_XS	4/4	1	126			:
ApKb	House	533	FB_Disco House_XS	4/4	1	126			:
ApKb	House	534	FC_Disco House_XS	4/4	1	126			:
ApKb	House	535	BA_Disco House_XS	4/4	1	126			:
ApKb	House	536	MD_Club House	4/4	1	128			:
ApKb	House	537	FC_Club House_ES	4/4	2	128			:
ApKb	House	538	MA_Garage 2	4/4	2	127			:
ApKb	House	539	MA_House P11	4/4	2	130			Acoustic Piano
ApKb	House	540	MA_House P12	4/4	1	130			:
ApKb	House	541	MA_House P13	4/4	1	130			:
ApKb	House	542	MA_House P14	4/4	1	130			:
ApKb	House	543	MA_House P15	4/4	1	130			:
ApKb	House	544	MA_Deep House1_ES	4/4	1	127			Electric Piano
ApKb	House	545	MA_Deep House2_ES	4/4	1	130			:
ApKb	House	546	MA_Deep House3_ES	4/4	1	127			:
ApKb	House	547	MA_Deep House4_ES	4/4	2	130			:
ApKb	House	548	MA_DA House	4/4	2	120			Acoustic Piano
ApKb	House	549	MA_Syn Clavi	4/4	1	126			Clavi
ApKb	Chill	550	MA_Ambient 3_ES	4/4	4	88			Electric Piano
ApKb	Chill	551	MB_Ambient 3_ES	4/4	4	88			:
ApKb	Chill	552	MC_Ambient 3_ES	4/4	4	88			:
ApKb	Chill	553	FA_Ambient 3_ES	4/4	1	88			:
ApKb	Chill	554	FB_Ambient 3_ES	4/4	1	88			:
ApKb	Chill	555	FC_Ambient 3_ES	4/4	1	88			:
ApKb	Chill	556	BA_Ambient 3_ES	4/4	1	88			:
ApKb	Jazz	557	MA_AcousticJazz_ES	4/4	4	204			Acoustic Piano
ApKb	Jazz	558	MB_AcousticJazz_ES	4/4	4	204			:
ApKb	Jazz	559	MC_AcousticJazz_ES	4/4	4	204			:
ApKb	Jazz	560	MD_AcousticJazz_ES	4/4	4	204			:
ApKb	Jazz	561	FA_AcousticJazz_ES	4/4	1	204			:
ApKb	Jazz	562	MA_JazzWaltzMed_XS	3/4	8	180			:
ApKb	Jazz	563	MB_JazzWaltzMed_XS	3/4	8	180			:
ApKb	Jazz	564	MC_JazzWaltzMed_XS	3/4	8	180			:
ApKb	Jazz	565	FA_JazzWaltzMed_XS	3/4	1	180			:
ApKb	Jazz	566	FB_JazzWaltzMed_XS	3/4	1	180			:
ApKb	Jazz	567	FC_JazzWaltzMed_XS	3/4	1	180			:
ApKb	Jazz	568	BA_JazzWaltzMed_XS	3/4	1	180			:
ApKb	Jazz	569	EA_JazzWaltzMed_XS	3/4	7	180			:
ApKb	Jazz	570	MA_R&R Shuffle_XS	4/4	4	192			:
ApKb	Jazz	571	MB_R&R Shuffle_XS	4/4	4	192			:
ApKb	Jazz	572	MC_R&R Shuffle_XS	4/4	4	192			:
ApKb	Jazz	573	FA_R&R Shuffle_XS	4/4	1	192			:
ApKb	Jazz	574	FB_R&R Shuffle_XS	4/4	1	192			:
ApKb	Jazz	575	FC_R&R Shuffle_XS	4/4	1	192			:

Main Category	Sub Category	ARP No.	ARP Name	Time Signature	Length	Original Tempo	Accent	Random SFX	Voice Type
ApKb	Jazz	576	BA_R&R Shuffle_XS	4/4	1	192			Acoustic Piano
ApKb	Jazz	577	EA_R&R Shuffle_XS	4/4	5	192			:
ApKb	Jazz	578	EB_R&R Shuffle_XS	4/4	5	192			:
ApKb	Jazz	579	MA_ShuffleBlues_XS	4/4	4	115			:
ApKb	Jazz	580	MB_ShuffleBlues_XS	4/4	4	115			:
ApKb	Jazz	581	MC_ShuffleBlues_XS	4/4	4	115			:
ApKb	Jazz	582	FA_ShuffleBlues_XS	4/4	1	115			:
ApKb	Jazz	583	FB_ShuffleBlues_XS	4/4	1	115			:
ApKb	Jazz	584	FC_ShuffleBlues_XS	4/4	1	115			:
ApKb	Jazz	585	BA_ShuffleBlues_XS	4/4	1	115			:
ApKb	Jazz	586	EA_ShuffleBlues_XS	4/4	5	115			:
ApKb	Jazz	587	EB_ShuffleBlues_XS	4/4	6	115			:
ApKb	Jazz	588	MA_Slow Blues 1_XS	4/4	2	49			:
ApKb	Jazz	589	MB_Slow Blues 1_XS	4/4	2	49			:
ApKb	Jazz	590	MC_Slow Blues 1_XS	4/4	2	49			:
ApKb	Jazz	591	FA_Slow Blues 1_XS	4/4	1	49			:
ApKb	Jazz	592	FB_Slow Blues 1_XS	4/4	1	49			:
ApKb	Jazz	593	FC_Slow Blues 1_XS	4/4	1	49			:
ApKb	Jazz	594	BA_Slow Blues 1_XS	4/4	1	49			:
ApKb	Jazz	595	EA_Slow Blues 1_XS	4/4	3	49			:
ApKb	Jazz	596	EB_Slow Blues 1_XS	4/4	3	49			:
ApKb	Jazz	597	MA_Piano Boogie_XS	4/4	8	160			:
ApKb	Jazz	598	MB_Piano Boogie_XS	4/4	4	160			:
ApKb	Jazz	599	MC_Piano Boogie_XS	4/4	4	160			:
ApKb	Jazz	600	FA_Piano Boogie_XS	4/4	1	160			:
ApKb	Jazz	601	FB_Piano Boogie_XS	4/4	1	160			:
ApKb	Jazz	602	FC_Piano Boogie_XS	4/4	1	160			:
ApKb	Jazz	603	BA_Piano Boogie_XS	4/4	1	160			:
ApKb	Jazz	604	EA_Piano Boogie_XS	4/4	5	160			:
ApKb	Jazz	605	EB_Piano Boogie_XS	4/4	5	160			:
ApKb	Latin	606	MA_Salsa 1_XS	4/4	4	177			:
ApKb	Latin	607	MB_Salsa 1_XS	4/4	4	177			:
ApKb	Latin	608	MC_Salsa 1_XS	4/4	4	177			:
ApKb	Latin	609	FA_Salsa 1_XS	4/4	1	177			:
ApKb	Latin	610	FB_Salsa 1_XS	4/4	1	177			:
ApKb	Latin	611	FC_Salsa 1_XS	4/4	1	177			:
ApKb	Latin	612	BA_Salsa 1_XS	4/4	1	177			:
ApKb	Latin	613	EA_Salsa 1_XS	4/4	5	177			:
ApKb	Latin	614	EB_Salsa 1_XS	4/4	5	177			:
ApKb	Latin	615	MA_Salsa 2_ES	4/4	1	123			:
ApKb	Latin	616	MB_Salsa 2_ES	4/4	1	123			:
ApKb	Latin	617	MC_Salsa 2	4/4	2	123			:
ApKb	Latin	618	MD_Salsa 2_ES	4/4	4	123			:
ApKb	Latin	619	FC_Salsa 2	4/4	2	123			:
ApKb	Latin	620	MA_AfroCuban_XS	4/4	4	200			:
ApKb	Latin	621	MB_AfroCuban_XS	4/4	4	200			:
ApKb	Latin	622	MC_AfroCuban_XS	4/4	4	200			:
ApKb	Latin	623	FA_AfroCuban_XS	4/4	1	200			:
ApKb	Latin	624	FB_AfroCuban_XS	4/4	1	200			:
ApKb	Latin	625	FC_AfroCuban_XS	4/4	1	200			:
ApKb	Latin	626	BA_AfroCuban_XS	4/4	1	200			:
ApKb	Latin	627	EA_AfroCuban_XS	4/4	6	200			:
ApKb	Latin	628	EB_AfroCuban_XS	4/4	5	200			:
ApKb	Latin	629	MA_Montuno_ES	4/4	1	100			:
ApKb	Latin	630	MC_Montuno_ES	4/4	2	100			:
ApKb	Latin	631	MD_Montuno_ES	4/4	2	100			:
ApKb	Latin	632	FA_Montuno_ES	4/4	1	100			:
ApKb	Latin	633	FC_Montuno_ES	4/4	1	100			:
ApKb	Latin	634	MA_Samba	4/4	1	120			:
ApKb	Latin	635	MB_Samba	4/4	4	120			:
ApKb	Latin	636	MC_Samba	4/4	4	120			:
ApKb	Latin	637	MA_Bomba_XS	4/4	4	99			:
ApKb	Latin	638	MB_Bomba_XS	4/4	4	99			:
ApKb	Latin	639	MC_Bomba_XS	4/4	4	99			:
ApKb	Latin	640	FA_Bomba_XS	4/4	1	99			:
ApKb	Latin	641	FB_Bomba_XS	4/4	1	99			:
ApKb	Latin	642	FC_Bomba_XS	4/4	1	99			:
ApKb	Latin	643	BA_Bomba_XS	4/4	1	99			:
ApKb	Latin	644	EA_Bomba_XS	4/4	3	99			:
ApKb	Latin	645	EB_Bomba_XS	4/4	3	99			:
ApKb	Latin	646	MA_Merengue_XS	4/4	4	130			:
ApKb	Latin	647	MB_Merengue_XS	4/4	4	130			:
ApKb	Latin	648	MC_Merengue_XS	4/4	4	130			:
ApKb	Latin	649	FA_Merengue_XS	4/4	1	130			:
ApKb	Latin	650	FB_Merengue_XS	4/4	1	130			:
ApKb	Latin	651	FC_Merengue_XS	4/4	1	130			:
ApKb	Latin	652	BA_Merengue_XS	4/4	1	130			:
ApKb	Latin	653	EA_Merengue_XS	4/4	3	130			:
ApKb	Latin	654	EB_Merengue_XS	4/4	3	130			:
ApKb	Latin	655	MA_Guaguanco_XS	4/4	4	120			:
ApKb	Latin	656	MB_Guaguanco_XS	4/4	4	120			:
ApKb	Latin	657	MC_Guaguanco_XS	4/4	4	120			:
ApKb	Latin	658	FA_Guaguanco_XS	4/4	1				

Main Category	Sub Category	ARP No.	ARP Name	Time Signature	Length	Original Tempo	Accent	Random SFX	Voice Type
ApKb	Latin	659	FB_Guaguanco_XS	4/4	1	120			Acoustic Piano
ApKb	Latin	660	FC_Guaguanco_XS	4/4	1	120			:
ApKb	Latin	661	BA_Guaguanco_XS	4/4	1	120			:
ApKb	Latin	662	EA_Guaguanco_XS	4/4	3	120			:
ApKb	Latin	663	EB_Guaguanco_XS	4/4	3	120			:
ApKb	Latin	664	MA1_Latin Rock	4/4	2	120			:
ApKb	Latin	665	MD1_Latin Rock	4/4	4	120			:
ApKb	Latin	666	FB1_Latin Rock	4/4	1	120			:
ApKb	Latin	667	MC2_Latin Rock	4/4	2	120			:
ApKb	Latin	668	FA2_Latin Rock	4/4	1	120			:
ApKb	Latin	669	MA_Disco Latin_XS	4/4	4	100			:
ApKb	Latin	670	MB_Disco Latin_XS	4/4	4	100			:
ApKb	Latin	671	MC_Disco Latin_XS	4/4	4	100			:
ApKb	Latin	672	FA_Disco Latin_XS	4/4	1	100			:
ApKb	Latin	673	FB_Disco Latin_XS	4/4	1	100			:
ApKb	Latin	674	FC_Disco Latin_XS	4/4	1	100			:
ApKb	Latin	675	BA_Disco Latin_XS	4/4	1	100			:
ApKb	Latin	676	IA_Latin House_ES	4/4	2	138			:
ApKb	Latin	677	FA_Latin House_ES	4/4	2	138			:
ApKb	Latin	678	FC_Latin House_ES	4/4	2	138			:
ApKb	Latin	679	MA_Piano Latin	4/4	2	120			:
ApKb	World	680	MA_Jumbo Reggae_XS	4/4	4	100			:
ApKb	World	681	MB_Jumbo Reggae_XS	4/4	4	100			:
ApKb	World	682	MC_Jumbo Reggae_XS	4/4	4	100			:
ApKb	World	683	FA_Jumbo Reggae_XS	4/4	1	100			:
ApKb	World	684	FB_Jumbo Reggae_XS	4/4	1	100			:
ApKb	World	685	FC_Jumbo Reggae_XS	4/4	1	100			:
ApKb	World	686	BA_Jumbo Reggae_XS	4/4	1	100			:
ApKb	World	687	EA_Jumbo Reggae_XS	4/4	3	100			:
ApKb	World	688	EB_Jumbo Reggae_XS	4/4	3	100			:
ApKb	World	689	MB1_Reggae 2	4/4	2	92			Electric Piano
ApKb	World	690	MD1_Reggae 2	4/4	2	92			:
ApKb	World	691	FA1_Reggae 2	4/4	1	92			:
ApKb	World	692	FB1_Reggae 2	4/4	1	92			:
ApKb	World	693	MA2_Reggae 2	4/4	2	92			Clavi
ApKb	World	694	MB2_Reggae 2	4/4	2	92			:
ApKb	World	695	MD2_Reggae 2	4/4	2	92			:
ApKb	World	696	IA2_Reggae 2	4/4	2	92			:
ApKb	World	697	FA2_Reggae 2	4/4	1	92			:
ApKb	World	698	MA_Saeidy_XS	4/4	2	120			:
ApKb	World	699	MB_Saeidy_XS	4/4	2	120			:
ApKb	World	700	MC_Saeidy_XS	4/4	4	120			:
ApKb	World	701	FA_Saeidy_XS	4/4	1	120			:
ApKb	World	702	FB_Saeidy_XS	4/4	1	120			:
ApKb	World	703	FC_Saeidy_XS	4/4	1	120			:
ApKb	World	704	BA_Saeidy_XS	4/4	1	120			:
ApKb	World	705	EA_Saeidy_XS	4/4	4	120			:
ApKb	Genrl	706	MA_Baroque_XS	4/4	4	88			Harpisichord
ApKb	Genrl	707	MB_Baroque_XS	4/4	4	88			:
ApKb	Genrl	708	MC_Baroque_XS	4/4	4	88			:
ApKb	Genrl	709	MD_Baroque_XS	4/4	4	88			:
ApKb	Genrl	710	FA_Baroque_XS	4/4	1	88			:
ApKb	Genrl	711	FB_Baroque_XS	4/4	1	88			:
ApKb	Genrl	712	FC_Baroque_XS	4/4	1	88			:
ApKb	Genrl	713	FD_Baroque_XS	4/4	1	88			:
ApKb	Genrl	714	MA_Pi Arp1	4/4	2	64			Acoustic Piano
ApKb	Genrl	715	MA_Pi Arp2	4/4	2	74			:
ApKb	Genrl	716	MA_Pi Arp3	4/4	2	124			:
ApKb	Genrl	717	MA_Pi Arp4	4/4	2	130			:
ApKb	Genrl	718	MA_Pi Arp5	4/4	2	130			:
ApKb	Genrl	719	MA_Pi Arp6	4/4	2	130			:
ApKb	Genrl	720	MA_Pi Arp7	4/4	2	130			:
ApKb	Genrl	721	MA_Pi Arp8	4/4	2	65			:
ApKb	Genrl	722	MA_Pi Arp9	4/4	1	116			:
ApKb	Genrl	723	MA_Pi Arp10	4/4	1	96			:
ApKb	Genrl	724	MA_Pi Arp11	4/4	1	82			:
ApKb	Genrl	725	MA_Pi Arp12	4/4	1	90			:
ApKb	Genrl	726	MA_Pi Arp13	4/4	1	90			:
ApKb	Genrl	727	MA_Pi Arp14	4/4	1	90			:
ApKb	Genrl	728	MA_Pi Arp15	4/4	1	90			:
ApKb	Genrl	729	MA_Pi Arp16	4/4	1	90			:
ApKb	Genrl	730	MA_Pi Arp17	4/4	1	100			:
ApKb	Genrl	731	MA_Pi Arp18	4/4	1	90			:
ApKb	Genrl	732	MA_Pi Arp19	4/4	1	84			:
ApKb	Genrl	733	MA_Pi Arp20	4/4	1	90			:
ApKb	Genrl	734	MA_Pi Arp21	4/4	1	86			:
ApKb	Genrl	735	MA_Pi Arp22	4/4	1	90			:
ApKb	Genrl	736	MA_Pi Arp23	4/4	1	90			:
ApKb	Genrl	737	MA_Pi Arp24	4/4	2	130			:
ApKb	Genrl	738	MA_Pi Arp25	4/4	2	130			:
ApKb	Genrl	739	MA_Pi Arp26	4/4	2	130			:
ApKb	Genrl	740	MA_Pi Arp27	4/4	2	130			:
ApKb	Genrl	741	MA_Pi Arp28	4/4	2	120			:

Main Category	Sub Category	ARP No.	ARP Name	Time Signature	Length	Original Tempo	Accent	Random SFX	Voice Type
ApKb	Genrl	742	MA_Pi Arp29	4/4	1	74			Acoustic Piano
Organ	Rock	743	MA_ProgresRock1_XS	4/4	4	110			Organ
Organ	Rock	744	MB_ProgresRock1_XS	4/4	3	110			:
Organ	Rock	745	MC_ProgresRock1_XS	4/4	4	110			:
Organ	Rock	746	FA_ProgresRock1_XS	4/4	1	110			:
Organ	Rock	747	FB_ProgresRock1_XS	4/4	1	110			:
Organ	Rock	748	FC_ProgresRock1_XS	4/4	1	110			:
Organ	Rock	749	BA_ProgresRock1_XS	4/4	1	110			:
Organ	Rock	750	MA_ProgresRock1_ES	4/4	4	110			:
Organ	Rock	751	MB_ProgresRock1_ES	4/4	3	110			:
Organ	Rock	752	MC_ProgresRock1_ES	4/4	4	110			:
Organ	Rock	753	FA_ProgresRock1_ES	4/4	1	110			:
Organ	Rock	754	FB_ProgresRock1_ES	4/4	1	110			:
Organ	Rock	755	FC_ProgresRock1_ES	4/4	1	110			:
Organ	Rock	756	BA_ProgresRock1_ES	4/4	1	110			:
Organ	Ballad	757	MA_6/8 Ballad_XS	6/8	4	87			:
Organ	Ballad	758	MB_6/8 Ballad_XS	6/8	4	87			:
Organ	Ballad	759	MC_6/8 Ballad_XS	6/8	4	87			:
Organ	Ballad	760	FA_6/8 Ballad_XS	6/8	1	87			:
Organ	Ballad	761	FB_6/8 Ballad_XS	6/8	1	87			:
Organ	Ballad	762	FC_6/8 Ballad_XS	6/8	1	87			:
Organ	Ballad	763	BA_6/8 Ballad_XS	6/8	1	87			:
Organ	Ballad	764	MA_6/8 Ballad_ES	6/8	4	87			:
Organ	Ballad	765	MB_6/8 Ballad_ES	6/8	4	87			:
Organ	Ballad	766	MC_6/8 Ballad_ES	6/8	4	87			:
Organ	Ballad	767	FA_6/8 Ballad_ES	6/8	1	87			:
Organ	Ballad	768	FB_6/8 Ballad_ES	6/8	1	87			:
Organ	Ballad	769	FC_6/8 Ballad_ES	6/8	1	87			:
Organ	Ballad	770	BA_6/8 Ballad_ES	6/8	1	87			:
Organ	HipHp	771	MD_Hip Hop 1_ES	4/4	2	105			:
Organ	HipHp	772	FC_Hip Hop 1_ES	4/4	2	105			:
Organ	R&B-C	773	MA_Soul 1_XS	4/4	2	116			:
Organ	R&B-C	774	MB_Soul 1_XS	4/4	2	116			:
Organ	R&B-C	775	MC_Soul 1_XS	4/4	2	116			:
Organ	R&B-C	776	FA_Soul 1_XS	4/4	1	116			:
Organ	R&B-C	777	FB_Soul 1_XS	4/4	1	116			:
Organ	R&B-C	778	FC_Soul 1_XS	4/4	1	116			:
Organ	R&B-C	779	BA_Soul 1_XS	4/4	1	116			:
Organ	R&B-C	780	EA_Soul 1_XS	4/4	4	116			:
Organ	R&B-C	781	EB_Soul 1_XS	4/4	3	116			:
Organ	R&B-C	782	MA_Soul 2	4/4	1	120			:
Organ	R&B-C	783	MB_Soul 2	4/4	4	120			:
Organ	R&B-C	784	FB_Soul 2_ES	4/4	1	120			:
Organ	Funk	785	MA_Jazz Funk 1_XS	4/4	4	120			:
Organ	Funk	786	MB_Jazz Funk 1_XS	4/4	4	120			:
Organ	Funk	787	MC_Jazz Funk 1_XS	4/4	4	120			:
Organ	Funk	788	FA_Jazz Funk 1_XS	4/4	1	120			:
Organ	Funk	789	FB_Jazz Funk 1_XS	4/4	1	120			:
Organ	Funk	790	FC_Jazz Funk 1_XS	4/4	1	120			:
Organ	Funk	791	BA_Jazz Funk 1_XS	4/4	1	120			:
Organ	Funk	792	EA_Jazz Funk 1_XS	4/4	3	120			:
Organ	Funk	793	EB_Jazz Funk 1_XS	4/4	3	120			:
Organ	Funk	794	MB_Jazz Funk 2	4/4	4	120			:
Organ	Funk	795	MA_Funk Organ1*	4/4	2	110			:
Organ	Funk	796	MA_Funk Organ2*	4/4	2	110			:
Organ	House	797	MA_House Organ1	4/4	1	130			:
Organ	House	798	MA_House Organ2	4/4	1	130			:
Organ	House	799	MA_House Organ3	4/4	1	130			:
Organ	House	800	MA_House Organ4	4/4	1	130			:
Organ	House	801	MA_House Organ5	4/4	2	126			:
Organ	Jazz	802	MA_Slow Blues 2_XS	4/4	4	72			:
Organ	Jazz	803	MB_Slow Blues 2_XS	4/4	4	72			:
Organ	Jazz	804	MC_Slow Blues 2_XS	4/4	4	72			:
Organ	Jazz	805	FA_Slow Blues 2_XS	4/4	1	72			:
Organ	Jazz	806	FB_Slow Blues 2_XS	4/4	1	72			:
Organ	Jazz	807	FC_Slow Blues 2_XS	4/4	1	72			:
Organ	Jazz	808	BA_Slow Blues 2_XS	4/4	1	72			:
Organ	Jazz	809	MA_Slow Blues 2_ES	4/4	4	72			:
Organ	Jazz	810	MB_Slow Blues 2_ES	4/4	4	72			:
Organ	Jazz	811	MC_Slow Blues 2_ES	4/4	4	72			:
Organ	Jazz	812	FA_Slow Blues 2_ES	4/4	1	72			:
Organ	Jazz	813	FB_Slow Blues 2_ES	4/4	1	72			:
Organ	Jazz	814	FC_Slow Blues 2_ES	4/4	1	72			:
Organ	Jazz	815	BA_Slow Blues 2_ES	4/4	1	72			:
Organ	Latin	816	MA_Latin Rock	4/4	2	120			:
Organ	Latin	817	MB_Latin Rock	4/4	2	120			:
Organ	Latin	818	MA_Latin Organ	4/4	1	110			:
Organ	World	819	MA_Reggae 1	4/4	4	102			:
Organ	World	820	MB_Reggae 1	4/4	4	102			:
Organ	World	821	MD_Reggae 1	4/4	4	90			:
Organ	World	822	FB_Reggae 1	4/4	1	102			:
Organ	World	823	MA_Reggae 2	4/4	1	92			:
Organ	World	824	MB_Reggae 2	4/4	2	92			:

Arpeggio Type List

Main Category	Sub Category	ARP No.	ARP Name	Time Signature	Length	Original Tempo	Accent	Random SFX	Voice Type
Organ	World	825	MC_Reggae 2	4/4	2	92			Organ
Organ	World	826	MD_Reggae 2	4/4	1	92			:
Organ	World	827	IA_Reggae 2	4/4	2	92			:
Organ	World	828	FB_Reggae 2	4/4	1	92			:
Organ	World	829	MA_ReggaeOrgan1*	4/4	2	120			:
Organ	World	830	MA_ReggaeOrgan2*	4/4	1	120			:
Organ	World	831	MA_Harmonium_ES	4/4	2	140			"India Harmonium"
Organ	World	832	MB_Harmonium_ES	4/4	2	140			:
Organ	World	833	MC_Harmonium_ES	4/4	2	140			:
Organ	World	834	MD_Harmonium_ES	4/4	2	140			:
Organ	World	835	ME_Harmonium_ES	4/4	2	140			:
GIPI	Rock	836	MA_OverdriveG1	4/4	4	120			Od/Dist Guitar
GIPI	Rock	837	MA_OverdriveG2_ES	4/4	4	120			:
GIPI	Rock	838	MA_OverdriveG3_ES	4/4	4	120			:
GIPI	Rock	839	MA_OverdriveG4_ES	4/4	4	120			:
GIPI	Rock	840	MA_OverdriveG5_ES	4/4	4	120			:
GIPI	Rock	841	MA_Guitar Over1	1/4	4	180			:
GIPI	Rock	842	MA_Guitar Over2_ES	1/4	4	120			:
GIPI	Rock	843	MA_ContempRock_XS	4/4	4	126			:
GIPI	Rock	844	MB_ContempRock_XS	4/4	4	126			:
GIPI	Rock	845	MC_ContempRock_XS	4/4	4	126			:
GIPI	Rock	846	FA_ContempRock_XS	4/4	1	126			:
GIPI	Rock	847	FB_ContempRock_XS	4/4	1	126			:
GIPI	Rock	848	FC_ContempRock_XS	4/4	1	126			:
GIPI	Rock	849	BA_ContempRock_XS	4/4	1	126			:
GIPI	Rock	850	EA_ContempRock_XS	4/4	4	126			:
GIPI	Rock	851	EB_ContempRock_XS	4/4	4	126			:
GIPI	Rock	852	MA1_70s Rock	4/4	2	130			Clean Guitar
GIPI	Rock	853	MB1_70s Rock	4/4	2	130			:
GIPI	Rock	854	MC1_70s Rock	4/4	4	130			:
GIPI	Rock	855	MD1_70s Rock_ES	4/4	2	130			:
GIPI	Rock	856	ME2_70s Rock_ES	4/4	4	130			Od/Dist Guitar
GIPI	Rock	857	MC2_70s Rock_ES	4/4	2	130			:
GIPI	Rock	858	MD2_70s Rock_ES	4/4	2	130			:
GIPI	Rock	859	FC2_70s Rock_ES	4/4	2	130			:
GIPI	Rock	860	MA3_70s Rock_ES	4/4	2	130			:
GIPI	Rock	861	MB3_70s Rock_ES	4/4	2	130			:
GIPI	Rock	862	MC3_70s Rock_ES	4/4	1	130			:
GIPI	Rock	863	MD3_70s Rock_ES	4/4	4	130			:
GIPI	Rock	864	MA_OverTheTop1	4/4	2	120			"Over The Top"
GIPI	Rock	865	MA_OverTheTop2	4/4	2	120			:
GIPI	Rock	866	MA_OverTheTop3	4/4	2	120			:
GIPI	Rock	867	MA_OverTheTop4	4/4	4	120			:
GIPI	Rock	868	MA_OverTheTop5	4/4	4	120			:
GIPI	Rock	869	MA_AlternaRock1_ES	4/4	4	97			Od/Dist Guitar
GIPI	Rock	870	MB_AlternaRock1_ES	4/4	4	97			:
GIPI	Rock	871	MC_AlternaRock1_ES	4/4	4	97			:
GIPI	Rock	872	FA_AlternaRock1_ES	4/4	1	97			:
GIPI	Rock	873	FB_AlternaRock1_ES	4/4	1	97			:
GIPI	Rock	874	FC_AlternaRock1_ES	4/4	1	97			:
GIPI	Rock	875	BA_AlternaRock1_ES	4/4	1	97			:
GIPI	Rock	876	MA_AlternaRock2_ES	4/4	4	100			:
GIPI	Rock	877	MB_AlternaRock2_ES	4/4	4	100			:
GIPI	Rock	878	MC_AlternaRock2_ES	4/4	4	100			:
GIPI	Rock	879	FA_AlternaRock2_ES	4/4	1	100			:
GIPI	Rock	880	FB_AlternaRock2_ES	4/4	1	100			:
GIPI	Rock	881	FC_AlternaRock2_ES	4/4	1	100			:
GIPI	Rock	882	BA_AlternaRock2_ES	4/4	2	100			:
GIPI	Rock	883	MC1_Xover Rock_ES	4/4	2	100			:
GIPI	Rock	884	MD1_Xover Rock_ES	4/4	2	100			:
GIPI	Rock	885	FB1_Xover Rock_ES	4/4	1	100			:
GIPI	Rock	886	FC1_Xover Rock_ES	4/4	2	100			:
GIPI	Rock	887	MA2_Xover Rock_ES	4/4	2	100			:
GIPI	Rock	888	MB2_Xover Rock_ES	4/4	1	100			:
GIPI	Rock	889	IA2_Xover Rock_ES	4/4	2	100			Clean Guitar
GIPI	Rock	890	FA2_Xover Rock_ES	4/4	1	100			:
GIPI	Rock	891	MA1_8Beat Rock_XS	4/4	4	75			:
GIPI	Rock	892	MB1_8Beat Rock_XS	4/4	4	75			:
GIPI	Rock	893	MC1_8Beat Rock_XS	4/4	4	75			:
GIPI	Rock	894	FA1_8Beat Rock_XS	4/4	1	75			:
GIPI	Rock	895	FB1_8Beat Rock_XS	4/4	1	75			:
GIPI	Rock	896	FC1_8Beat Rock_XS	4/4	1	75			:
GIPI	Rock	897	BA1_8Beat Rock_XS	4/4	1	75			:
GIPI	Rock	898	MA1_8Beat Rock_ES	4/4	4	75			:
GIPI	Rock	899	MB1_8Beat Rock_ES	4/4	4	75			:
GIPI	Rock	900	MC1_8Beat Rock_ES	4/4	4	75			:
GIPI	Rock	901	FA1_8Beat Rock_ES	4/4	1	75			:
GIPI	Rock	902	FB1_8Beat Rock_ES	4/4	1	75			:
GIPI	Rock	903	FC1_8Beat Rock_ES	4/4	1	75			:
GIPI	Rock	904	BA1_8Beat Rock_ES	4/4	1	75			:
GIPI	Rock	905	MA2_8Beat Rock_XS	4/4	4	75			Od/Dist Guitar
GIPI	Rock	906	MB2_8Beat Rock_XS	4/4	4	75			:
GIPI	Rock	907	MC2_8Beat Rock_XS	4/4	4	75			:

Main Category	Sub Category	ARP No.	ARP Name	Time Signature	Length	Original Tempo	Accent	Random SFX	Voice Type
GIPI	Rock	908	FA2_8Beat Rock_XS	4/4	1	75			Od/Dist Guitar
GIPI	Rock	909	FB2_8Beat Rock_XS	4/4	1	75			:
GIPI	Rock	910	FC2_8Beat Rock_XS	4/4	1	75			:
GIPI	Rock	911	BA2_8Beat Rock_XS	4/4	1	75			:
GIPI	Rock	912	MA2_8Beat Rock_ES	4/4	4	75			:
GIPI	Rock	913	MB2_8Beat Rock_ES	4/4	4	75			:
GIPI	Rock	914	MC2_8Beat Rock_ES	4/4	4	75			:
GIPI	Rock	915	FA2_8Beat Rock_ES	4/4	1	75			:
GIPI	Rock	916	FB2_8Beat Rock_ES	4/4	1	75			:
GIPI	Rock	917	FC2_8Beat Rock_ES	4/4	1	75			:
GIPI	Rock	918	BA2_8Beat Rock_ES	4/4	1	75			:
GIPI	Rock	919	MA_16Beat Rock_XS	4/4	4	86			"Over The Top"
GIPI	Rock	920	MB_16Beat Rock_XS	4/4	4	86			:
GIPI	Rock	921	MC_16Beat Rock_XS	4/4	4	86			:
GIPI	Rock	922	FA_16Beat Rock_XS	4/4	1	86			:
GIPI	Rock	923	FB_16Beat Rock_XS	4/4	1	86			:
GIPI	Rock	924	FC_16Beat Rock_XS	4/4	1	86			:
GIPI	Rock	925	BA_16Beat Rock_XS	4/4	1	86			:
GIPI	Rock	926	MA_16Beat Rock	4/4	4	86			:
GIPI	Rock	927	MB_16Beat Rock_ES	4/4	4	86			:
GIPI	Rock	928	MC_16Beat Rock_ES	4/4	4	86			:
GIPI	Rock	929	FA_16Beat Rock	4/4	1	86			:
GIPI	Rock	930	FB_16Beat Rock_ES	4/4	1	86			:
GIPI	Rock	931	FC_16Beat Rock_ES	4/4	1	86			:
GIPI	Rock	932	BA_16Beat Rock_ES	4/4	1	86			:
GIPI	Rock	933	MA_ProgresRock1_XS	4/4	4	110			"DriveWah (2handGtr)"
GIPI	Rock	934	MB_ProgresRock1_XS	4/4	3	110			:
GIPI	Rock	935	MC_ProgresRock1_XS	4/4	4	110			:
GIPI	Rock	936	FA_ProgresRock1_XS	4/4	1	110			:
GIPI	Rock	937	FB_ProgresRock1_XS	4/4	1	110			:
GIPI	Rock	938	FC_ProgresRock1_XS	4/4	1	110			:
GIPI	Rock	939	BA_ProgresRock1_XS	4/4	1	110			:
GIPI	Rock	940	MA_ProgresRock1_ES	4/4	4	110			:
GIPI	Rock	941	MB_ProgresRock1_ES	4/4	3	110			:
GIPI	Rock	942	MC_ProgresRock1_ES	4/4	4	110			:
GIPI	Rock	943	FA_ProgresRock1_ES	4/4	1	110			:
GIPI	Rock	944	FB_ProgresRock1_ES	4/4	1	110			:
GIPI	Rock	945	FC_ProgresRock1_ES	4/4	1	110			:
GIPI	Rock	946	BA_ProgresRock1_ES	4/4	1	110			:
GIPI	Rock	947	MA_ProgresRock2_XS	4/4	4	120			Clean Guitar
GIPI	Rock	948	MB_ProgresRock2_XS	4/4	4	120			:
GIPI	Rock	949	MC_ProgresRock2_XS	4/4	4	120			:
GIPI	Rock	950	FA_ProgresRock2_XS	4/4	1	120			:
GIPI	Rock	951	FB_ProgresRock2_XS	4/4	1	120			:
GIPI	Rock	952	FC_ProgresRock2_XS	4/4	1	120			:
GIPI	Rock	953	BA_ProgresRock2_XS	4/4	1	120			:
GIPI	Rock	954	MA_ProgresRock2_ES	4/4	4	120			:
GIPI	Rock	955	MB_ProgresRock2_ES	4/4	4	120			:
GIPI	Rock	956	MC_ProgresRock2_ES	4/4	4	120			:
GIPI	Rock	957	FA_ProgresRock2_ES	4/4	1	120			:
GIPI	Rock	958	FB_ProgresRock2_ES	4/4	1	120			:
GIPI	Rock	959	FC_ProgresRock2_ES	4/4	1	120			:
GIPI	Rock	960	BA_ProgresRock2_ES	4/4	1	120			:
GIPI	Rock	961	MA_Rock Guitar1	4/4	1	120			Od/Dist Guitar
GIPI	Rock	962	MA_Rock Guitar2	4/4	1	120			:
GIPI	Rock	963	MA_Rock Guitar3	4/4	1	120			:
GIPI	PopRk	964	MA_Guitar Pop 1_XS	4/4	4	100			Acoustic Guitar
GIPI	PopRk	965	MB_Guitar Pop 1_XS	4/4	4	100			:
GIPI	PopRk	966	MC_Guitar Pop 1_XS	4/4	4	100			:
GIPI	PopRk	967	FA_Guitar Pop 1_XS	4/4	1	100			:
GIPI	PopRk	968	FB_Guitar Pop 1_XS	4/4	1	100			:
GIPI	PopRk	969	FC_Guitar Pop 1_XS	4/4	1	100			:
GIPI	PopRk	970	BA_Guitar Pop 1_XS	4/4	1	100			:
GIPI	PopRk	971	EA_Guitar Pop 1_XS	4/4	3	100			:
GIPI	PopRk	972	EB_Guitar Pop 1_XS	4/4	3	100			:
GIPI	PopRk	973	MA1_Guitar Pop 2	4/4	2	90			:
GIPI	PopRk	974	MA1_Guitar Pop 2 AF2	4/4	2	90			Aco Guitar / Syn Pad
GIPI	PopRk	975	MB1_Guitar Pop 2	4/4	1	90			Acoustic Guitar
GIPI	PopRk	976	MC1_Guitar Pop 2	4/4	2	90			:
GIPI	PopRk	977	IA1_Guitar Pop 2	4/4	1	90			:
GIPI	PopRk	978	MA2_Guitar Pop 2	4/4	1	90			:
GIPI	PopRk	979	IA2_Guitar Pop 2	4/4	1	90			Clean Guitar
GIPI	PopRk	980	MA1_FingerPickin_ES	4/4	2	120			Acoustic Guitar
GIPI	PopRk	981	MB1_FingerPickin_ES	4/4	2	120			:
GIPI	PopRk	982	MC1_FingerPickin_ES	4/4	2	120			:
GIPI	PopRk	983	MD1_FingerPickin_ES	4/4	3	120			:
GIPI	PopRk	984	IA1_FingerPickin	4/4	1	120			:
GIPI	PopRk	985	FA1_FingerPickin_ES	4/4	1	120			:
GIPI	PopRk	986	FB1_FingerPickin_ES	4/4	1	120			:
GIPI	PopRk	987	MA2_FingerPickin	4/4	2	120			:
GIPI	PopRk	988	MB2_FingerPickin	4/4	2	120			:
GIPI	PopRk	989	MC2_FingerPickin	4/4	2	120			:
GIPI	PopRk	990	MD2_FingerPickin	4/4	2	120			:

Arpeggio Type List

Main Category	Sub Category	ARP No.	ARP Name	Time Signature	Length	Original Tempo	Accent	Random SFX	Voice Type
GIPI	PopRk	991	IA2_FingerPickin	4/4	2	120			Acoustic Guitar
GIPI	PopRk	992	FA2_FingerPickin	4/4	1	120			:
GIPI	PopRk	993	FB2_FingerPickin	4/4	1	120			:
GIPI	PopRk	994	MA_Pickin1	4/4	3	120			:
GIPI	PopRk	995	MA_Pickin2	4/4	2	120			:
GIPI	PopRk	996	MA_Pickin3	4/4	2	120			:
GIPI	PopRk	997	MA1_Folk Rock_ES	4/4	2	120			:
GIPI	PopRk	998	MB1_Folk Rock_ES	4/4	2	120			:
GIPI	PopRk	999	IA1_Folk Rock_ES	4/4	1	120			:
GIPI	PopRk	1000	IA1_FolkRock AF1_ES	4/4	1	80			:
GIPI	PopRk	1001	IA1_FolkRock AF1&2_ES	4/4	1	80			:
GIPI	PopRk	1002	MA2_Folk Rock_ES	4/4	2	120			:
GIPI	PopRk	1003	MB2_Folk Rock_ES	4/4	2	120			:
GIPI	PopRk	1004	MC2_Folk Rock_ES	4/4	2	120			:
GIPI	PopRk	1005	IA2_Folk Rock_ES	4/4	1	120			:
GIPI	PopRk	1006	IA2_FolkRock AF1_ES	4/4	1	80			:
GIPI	PopRk	1007	MC3_Folk Rock_ES	4/4	2	120			Clean Guitar
GIPI	PopRk	1008	MD3_Folk Rock_ES	4/4	2	120			:
GIPI	PopRk	1009	FA3_Folk Rock_ES	4/4	1	120			:
GIPI	PopRk	1010	MA_12 GuitarA1_ES	4/4	4	120			Acoustic Guitar
GIPI	PopRk	1011	MA_12 GuitarA2_ES	4/4	4	120			:
GIPI	PopRk	1012	MA_12 GuitarA3_ES	4/4	4	120			:
GIPI	PopRk	1013	MA_12 GuitarA4_ES	4/4	4	120			:
GIPI	PopRk	1014	MA_12 GuitarA5_ES	4/4	4	120			:
GIPI	PopRk	1015	MA_12 GuitarB1	4/4	1	97			:
GIPI	PopRk	1016	MA_12 GuitarB2	4/4	1	100			:
GIPI	PopRk	1017	MA_Worship Fast_XS	4/4	8	114			:
GIPI	PopRk	1018	MB_Worship Fast_XS	4/4	4	114			:
GIPI	PopRk	1019	MC_Worship Fast_XS	4/4	4	114			:
GIPI	PopRk	1020	FA_Worship Fast_XS	4/4	1	114			:
GIPI	PopRk	1021	FB_Worship Fast_XS	4/4	1	114			:
GIPI	PopRk	1022	FC_Worship Fast_XS	4/4	1	114			:
GIPI	PopRk	1023	BA_Worship Fast_XS	4/4	1	114			:
GIPI	PopRk	1024	EA_Worship Fast_XS	4/4	4	114			:
GIPI	PopRk	1025	EB_Worship Fast_XS	4/4	2	114			:
GIPI	PopRk	1026	MA_New Country_XS	4/4	2	118			:
GIPI	PopRk	1027	MB_New Country_XS	4/4	4	118			:
GIPI	PopRk	1028	MC_New Country_XS	4/4	2	118			:
GIPI	PopRk	1029	FA_New Country_XS	4/4	1	118			:
GIPI	PopRk	1030	FB_New Country_XS	4/4	1	118			:
GIPI	PopRk	1031	FC_New Country_XS	4/4	1	118			:
GIPI	PopRk	1032	BA_New Country_XS	4/4	1	118			:
GIPI	PopRk	1033	EA_New Country_XS	4/4	4	118			:
GIPI	PopRk	1034	EB_New Country_XS	4/4	4	118			:
GIPI	PopRk	1035	MA_New Country	4/4	2	118			:
GIPI	PopRk	1036	MB_New Country	4/4	4	118			:
GIPI	PopRk	1037	MC_New Country	4/4	2	118			:
GIPI	PopRk	1038	FA_New Country	4/4	1	118			:
GIPI	PopRk	1039	FB_New Country	4/4	1	118			:
GIPI	PopRk	1040	FC_New Country	4/4	1	118			:
GIPI	PopRk	1041	BA_New Country	4/4	1	118			:
GIPI	PopRk	1042	MA_BritPopSwing_XS	4/4	2	110			Clean Guitar
GIPI	PopRk	1043	MB_BritPopSwing_XS	4/4	2	110			:
GIPI	PopRk	1044	MC_BritPopSwing_XS	4/4	2	110			:
GIPI	PopRk	1045	FA_BritPopSwing_XS	4/4	1	110			:
GIPI	PopRk	1046	FB_BritPopSwing_XS	4/4	1	110			:
GIPI	PopRk	1047	FC_BritPopSwing_XS	4/4	1	110			:
GIPI	PopRk	1048	BA_BritPopSwing_XS	4/4	1	110			:
GIPI	PopRk	1049	EA_BritPopSwing_XS	4/4	4	110			:
GIPI	PopRk	1050	EB_BritPopSwing_XS	4/4	4	110			:
GIPI	PopRk	1051	MA_8Beat Basic_XS	4/4	4	120			:
GIPI	PopRk	1052	MB_8Beat Basic_XS	4/4	4	120			:
GIPI	PopRk	1053	MC_8Beat Basic_XS	4/4	4	120			:
GIPI	PopRk	1054	FA_8Beat Basic_XS	4/4	1	120			:
GIPI	PopRk	1055	FB_8Beat Basic_XS	4/4	1	120			:
GIPI	PopRk	1056	FC_8Beat Basic_XS	4/4	1	120			:
GIPI	PopRk	1057	BA_8Beat Basic_XS	4/4	1	120			:
GIPI	PopRk	1058	MA_8Beat Basic_ES	4/4	4	120			:
GIPI	PopRk	1059	MB_8Beat Basic_ES	4/4	4	120			:
GIPI	PopRk	1060	MC_8Beat Basic_ES	4/4	4	120			:
GIPI	PopRk	1061	FA_8Beat Basic_ES	4/4	1	120			:
GIPI	PopRk	1062	FB_8Beat Basic_ES	4/4	1	120			:
GIPI	PopRk	1063	FC_8Beat Basic_ES	4/4	1	120			:
GIPI	PopRk	1064	BA_8Beat Basic_ES	4/4	1	120			:
GIPI	PopRk	1065	MA_8Beat Soft_XS	4/4	4	100			Acoustic Guitar
GIPI	PopRk	1066	MB_8Beat Soft_XS	4/4	4	100			:
GIPI	PopRk	1067	MC_8Beat Soft_XS	4/4	4	100			:
GIPI	PopRk	1068	FA_8Beat Soft_XS	4/4	1	100			:
GIPI	PopRk	1069	FB_8Beat Soft_XS	4/4	1	100			:
GIPI	PopRk	1070	FC_8Beat Soft_XS	4/4	1	100			:
GIPI	PopRk	1071	BA_8Beat Soft_XS	4/4	1	100			:
GIPI	PopRk	1072	MA_8Beat Soft_ES	4/4	4	100			:
GIPI	PopRk	1073	MB_8Beat Soft_ES	4/4	4	100			:

Main Category	Sub Category	ARP No.	ARP Name	Time Signature	Length	Original Tempo	Accent	Random SFX	Voice Type
GIPI	PopRk	1074	MC_8Beat Soft_ES	4/4	4	100			Acoustic Guitar
GIPI	PopRk	1075	FA_8Beat Soft_ES	4/4	1	100			:
GIPI	PopRk	1076	FB_8Beat Soft_ES	4/4	1	100			:
GIPI	PopRk	1077	FC_8Beat Soft_ES	4/4	1	100			:
GIPI	PopRk	1078	BA_8Beat Soft_ES	4/4	1	100			:
GIPI	PopRk	1079	MA_1_Soft Rock_ES	4/4	4	120			:
GIPI	PopRk	1080	MB_1_Soft Rock_ES	4/4	4	120			:
GIPI	PopRk	1081	MC_1_Soft Rock_ES	4/4	2	120			:
GIPI	PopRk	1082	MD_1_Soft Rock_ES	4/4	2	120			:
GIPI	PopRk	1083	IA_1_Soft Rock_ES	4/4	1	120			:
GIPI	PopRk	1084	FA_1_Soft Rock_ES	4/4	1	120			:
GIPI	PopRk	1085	FB_1_Soft Rock_ES	4/4	1	120			:
GIPI	PopRk	1086	MD_2_Soft Rock_ES	4/4	2	120			Od/Dist Guitar
GIPI	PopRk	1087	FB_2_Soft Rock_ES	4/4	1	120			:
GIPI	PopRk	1088	MA_16BeatBasic1_XS	4/4	4	90			Clean Guitar
GIPI	PopRk	1089	MB_16BeatBasic1_XS	4/4	4	90			:
GIPI	PopRk	1090	MC_16BeatBasic1_XS	4/4	4	90			:
GIPI	PopRk	1091	FA_16BeatBasic1_XS	4/4	1	90			:
GIPI	PopRk	1092	FB_16BeatBasic1_XS	4/4	1	90			:
GIPI	PopRk	1093	FC_16BeatBasic1_XS	4/4	1	90			:
GIPI	PopRk	1094	BA_16BeatBasic1_XS	4/4	1	90			:
GIPI	PopRk	1095	MA_16BeatBasic1_ES	4/4	4	90			:
GIPI	PopRk	1096	MB_16BeatBasic1_ES	4/4	4	90			:
GIPI	PopRk	1097	MC_16BeatBasic1_ES	4/4	4	90			:
GIPI	PopRk	1098	FA_16BeatBasic1_ES	4/4	1	90			:
GIPI	PopRk	1099	FB_16BeatBasic1_ES	4/4	1	90			:
GIPI	PopRk	1100	FC_16BeatBasic1_ES	4/4	1	90			:
GIPI	PopRk	1101	BA_16BeatBasic1_ES	4/4	1	90			:
GIPI	PopRk	1102	MA_Analog Pop	4/4	2	93			:
GIPI	PopRk	1103	MC_Analog Pop	4/4	1	93			:
GIPI	PopRk	1104	IA_Analog Pop	4/4	1	93			:
GIPI	PopRk	1105	MA_6/8 Pop_XS	4/4	4	100			Od/Dist Guitar
GIPI	PopRk	1106	MB_6/8 Pop_XS	4/4	4	100			:
GIPI	PopRk	1107	MC_6/8 Pop_XS	4/4	4	100			:
GIPI	PopRk	1108	FA_6/8 Pop_XS	4/4	1	100			:
GIPI	PopRk	1109	FB_6/8 Pop_XS	4/4	1	100			:
GIPI	PopRk	1110	FC_6/8 Pop_XS	4/4	1	100			:
GIPI	PopRk	1111	BA_6/8 Pop_XS	4/4	1	100			:
GIPI	PopRk	1112	EA_6/8 Pop_XS	4/4	3	123			:
GIPI	PopRk	1113	MA_6/8 Pop_ES	4/4	4	100			:
GIPI	PopRk	1114	MB_6/8 Pop_ES	4/4	4	100			:
GIPI	PopRk	1115	MC_6/8 Pop_ES	4/4	4	100			:
GIPI	PopRk	1116	FA_6/8 Pop_ES	4/4	1	100			:
GIPI	PopRk	1117	FB_6/8 Pop_ES	4/4	1	100			:
GIPI	PopRk	1118	FC_6/8 Pop_ES	4/4	1	100			:
GIPI	PopRk	1119	BA_6/8 Pop_ES	4/4	1	100			:
GIPI	Ballad	1120	MA_Unplugged 3_XS	4/4	4	113			Acoustic Guitar
GIPI	Ballad	1121	MB_Unplugged 3_XS	4/4	4	113			:
GIPI	Ballad	1122	MC_Unplugged 3_XS	4/4	4	113			:
GIPI	Ballad	1123	FA_Unplugged 3_XS	4/4	1	113			:
GIPI	Ballad	1124	FB_Unplugged 3_XS	4/4	1	113			:
GIPI	Ballad	1125	FC_Unplugged 3_XS	4/4	1	113			:
GIPI	Ballad	1126	BA_Unplugged 3_XS	4/4	1	113			:
GIPI	Ballad	1127	MA_Unplugged 3_ES	4/4	4	113			:
GIPI	Ballad	1128	MB_Unplugged 3_ES	4/4	4	113			:
GIPI	Ballad	1129	MC_Unplugged 3_ES	4/4	4	113			:
GIPI	Ballad	1130	FA_Unplugged 3_ES	4/4	1	113			:
GIPI	Ballad	1131	FB_Unplugged 3_ES	4/4	1	113			:
GIPI	Ballad	1132	FC_Unplugged 3_ES	4/4	1	113			:
GIPI	Ballad	1133	BA_Unplugged 3_ES	4/4	1	113			:
GIPI	Ballad	1134	MA_Unplugged 4	4/4	4	120			:
GIPI	Ballad	1135	MB_Unplugged 4	4/4	2	120			:
GIPI	Ballad	1136	MC_Unplugged 4	4/4	2	120			:
GIPI	Ballad	1137	MD_Unplugged 4	4/4	2	120			:
GIPI	Ballad	1138	FA_Unplugged 4	4/4	1	120			:
GIPI	Ballad	1139	FB_Unplugged 4	4/4	1	120			:
GIPI	Ballad	1140	EA_Unplugged 4	4/4	4	120			:
GIPI	Ballad	1141	EB_Unplugged 4	4/4	3	120			:
GIPI	Ballad	1142	MA_8Beat Ballad_XS	4/4	4	101			:
GIPI	Ballad	1143	MB_8Beat Ballad_XS	4/4	4	101			:
GIPI	Ballad	1144	MC_8Beat Ballad_XS	4/4	4	101			:
GIPI	Ballad	1145	FA_8Beat Ballad_XS	4/4	1	101			:
GIPI	Ballad	1146	FB_8Beat Ballad_XS	4/4	1	101			:
GIPI	Ballad	1147	FC_8Beat Ballad_XS	4/4	1	101			:
GIPI	Ballad	1148	BA_8Beat Ballad_XS	4/4	1	101			:
GIPI	Ballad	1149	EA_8Beat Ballad_XS	4/4	5	101			:
GIPI	Ballad	1150	EB_8Beat Ballad_XS	4/4	5	101			:
GIPI	Ballad	1151	MA_8Beat Ballad	4/4	4	101			:
GIPI	Ballad	1152	MB_8Beat Ballad	4/4	4	1			

Arpeggio Type List

Main Category	Sub Category	ARP No.	ARP Name	Time Signature	Length	Original Tempo	Accent	Random SFX	Voice Type
GIPI	Balad	1157	BA_8Beat Ballad	4/4	1	101			Acoustic Guitar
GIPI	Balad	1158	MA_Slowfeel	4/4	1	74			:
GIPI	Balad	1159	MB_Slowfeel	4/4	1	74			:
GIPI	Balad	1160	MC_Slowfeel	4/4	1	74			Clean Guitar
GIPI	Balad	1161	MA_16Bt Ballad1_XS	4/4	4	75			:
GIPI	Balad	1162	MB_16Bt Ballad1_XS	4/4	4	75			:
GIPI	Balad	1163	MC_16Bt Ballad1_XS	4/4	4	75			:
GIPI	Balad	1164	FA_16Bt Ballad1_XS	4/4	1	75			:
GIPI	Balad	1165	FB_16Bt Ballad1_XS	4/4	1	75			:
GIPI	Balad	1166	FC_16Bt Ballad1_XS	4/4	1	75			:
GIPI	Balad	1167	BA_16Bt Ballad1_XS	4/4	1	75			:
GIPI	Balad	1168	MA_16Bt Ballad1_ES	4/4	4	75			:
GIPI	Balad	1169	MB_16Bt Ballad1_ES	4/4	4	75			:
GIPI	Balad	1170	MC_16Bt Ballad1_ES	4/4	4	75			:
GIPI	Balad	1171	FA_16Bt Ballad1_ES	4/4	1	75			:
GIPI	Balad	1172	FB_16Bt Ballad1_ES	4/4	1	75			:
GIPI	Balad	1173	FC_16Bt Ballad1_ES	4/4	1	75			:
GIPI	Balad	1174	BA_16Bt Ballad1_ES	4/4	1	75			:
GIPI	Balad	1175	MA_6/8 Ballad_XS	6/8	4	87			Od/Dist Guitar
GIPI	Balad	1176	MB_6/8 Ballad_XS	6/8	4	87			:
GIPI	Balad	1177	MC_6/8 Ballad_XS	6/8	4	87			:
GIPI	Balad	1178	FA_6/8 Ballad_XS	6/8	1	87			:
GIPI	Balad	1179	FB_6/8 Ballad_XS	6/8	1	87			:
GIPI	Balad	1180	FC_6/8 Ballad_XS	6/8	1	87			:
GIPI	Balad	1181	BA_6/8 Ballad_XS	6/8	1	87			:
GIPI	Balad	1182	EA_6/8 Ballad_XS	6/8	6	87			:
GIPI	Balad	1183	EB_6/8 Ballad_XS	6/8	6	87			:
GIPI	Balad	1184	MA_6/8 Ballad_ES	6/8	4	87			:
GIPI	Balad	1185	MB_6/8 Ballad_ES	6/8	4	87			:
GIPI	Balad	1186	MC_6/8 Ballad_ES	6/8	4	87			:
GIPI	Balad	1187	FA_6/8 Ballad_ES	6/8	1	87			:
GIPI	Balad	1188	FB_6/8 Ballad_ES	6/8	1	87			:
GIPI	Balad	1189	FC_6/8 Ballad_ES	6/8	1	87			:
GIPI	Balad	1190	BA_6/8 Ballad_ES	6/8	1	87			:
GIPI	HipHp	1191	MA_PepRally_ES	4/4	1	75			Clean Guitar
GIPI	HipHp	1192	MB_PepRally_ES	4/4	1	75			:
GIPI	HipHp	1193	MC_PepRally_ES	4/4	1	75			:
GIPI	HipHp	1194	MD_PepRally_ES	4/4	1	75			:
GIPI	HipHp	1195	MA_Hip Hop 2_ES	4/4	2	94			Mute Guitar
GIPI	HipHp	1196	MC_Hip Hop 2_ES	4/4	2	94			:
GIPI	HipHp	1197	MD_Hip Hop 2_ES	4/4	2	94			:
GIPI	HipHp	1198	IA_Hip Hop 2_ES	4/4	2	94			:
GIPI	HipHp	1199	MA1_Hip Hop 3	4/4	2	104			Acoustic Guitar
GIPI	HipHp	1200	MB1_Hip Hop 3	4/4	2	104			:
GIPI	HipHp	1201	MC1_Hip Hop 3	4/4	2	104			:
GIPI	HipHp	1202	MD1_Hip Hop 3	4/4	2	104			:
GIPI	HipHp	1203	FC1_Hip Hop 3	4/4	2	104			:
GIPI	HipHp	1204	MA2_Hip Hop 3_ES	4/4	2	104			Mute Guitar
GIPI	HipHp	1205	MB2_Hip Hop 3_ES	4/4	2	104			:
GIPI	HipHp	1206	MD2_Hip Hop 3_ES	4/4	2	104			:
GIPI	HipHp	1207	FA2_Hip Hop 3_ES	4/4	1	104			:
GIPI	HipHp	1208	FC2_Hip Hop 3_ES	4/4	2	104			:
GIPI	HipHp	1209	MA1_Hip Hop 6_XS	4/4	4	96			Acoustic Guitar
GIPI	HipHp	1210	MB1_Hip Hop 6_XS	4/4	4	96			:
GIPI	HipHp	1211	MC1_Hip Hop 6_XS	4/4	4	96			:
GIPI	HipHp	1212	FA1_Hip Hop 6_XS	4/4	1	96			:
GIPI	HipHp	1213	FB1_Hip Hop 6_XS	4/4	1	96			:
GIPI	HipHp	1214	FC1_Hip Hop 6_XS	4/4	1	96			:
GIPI	HipHp	1215	BA1_Hip Hop 6_XS	4/4	1	96			:
GIPI	HipHp	1216	MA2_Hip Hop 6_XS	4/4	4	96			Od/Dist Guitar
GIPI	HipHp	1217	MB2_Hip Hop 6_XS	4/4	4	96			:
GIPI	HipHp	1218	MC2_Hip Hop 6_XS	4/4	4	96			:
GIPI	HipHp	1219	FA2_Hip Hop 6_XS	4/4	1	96			:
GIPI	HipHp	1220	FB2_Hip Hop 6_XS	4/4	1	96			:
GIPI	HipHp	1221	FC2_Hip Hop 6_XS	4/4	1	96			:
GIPI	HipHp	1222	BA2_Hip Hop 6_XS	4/4	1	96			:
GIPI	HipHp	1223	MA_Hip Rock 1_XS	4/4	4	90			:
GIPI	HipHp	1224	MB_Hip Rock 1_XS	4/4	4	90			:
GIPI	HipHp	1225	MC_Hip Rock 1_XS	4/4	4	90			:
GIPI	HipHp	1226	FA_Hip Rock 1_XS	4/4	1	90			:
GIPI	HipHp	1227	FB_Hip Rock 1_XS	4/4	1	90			:
GIPI	HipHp	1228	FC_Hip Rock 1_XS	4/4	1	90			:
GIPI	HipHp	1229	MA_Hip Rock 2_XS	4/4	4	132			:
GIPI	HipHp	1230	MB_Hip Rock 2_XS	4/4	4	132			:
GIPI	HipHp	1231	MC_Hip Rock 2_XS	4/4	4	132			:
GIPI	HipHp	1232	FA_Hip Rock 2_XS	4/4	1	132			:
GIPI	HipHp	1233	FB_Hip Rock 2_XS	4/4	1	132			:
GIPI	HipHp	1234	FC_Hip Rock 2_XS	4/4	1	132			:
GIPI	HipHp	1235	BA_Hip Rock 2_XS	4/4	1	132			:
GIPI	HipHp	1236	MB1_ClasichipHop_ES	4/4	2	90			Clean Guitar
GIPI	HipHp	1237	MC1_ClasichipHop_ES	4/4	2	90			:
GIPI	HipHp	1238	MA2_ClasichipHop	4/4	2	90			:
GIPI	HipHp	1239	MB2_ClasichipHop	4/4	2	90			:

Main Category	Sub Category	ARP No.	ARP Name	Time Signature	Length	Original Tempo	Accent	Random SFX	Voice Type
GIPI	HipHp	1240	MC2_ClasichipHop	4/4	2	90			Clean Guitar
GIPI	HipHp	1241	IA2_ClasichipHop	4/4	4	90			:
GIPI	HipHp	1242	MD3_ClasichipHop	4/4	2	90			:
GIPI	HipHp	1243	FC3_ClasichipHop_ES	4/4	2	90			:
GIPI	R&B-M	1244	MA_Pop Shuffle1_XS	4/4	4	94			:
GIPI	R&B-M	1245	MB_Pop Shuffle1_XS	4/4	4	94			:
GIPI	R&B-M	1246	MC_Pop Shuffle1_XS	4/4	4	94			:
GIPI	R&B-M	1247	FA_Pop Shuffle1_XS	4/4	1	94			:
GIPI	R&B-M	1248	FB_Pop Shuffle1_XS	4/4	1	94			:
GIPI	R&B-M	1249	FC_Pop Shuffle1_XS	4/4	1	94			:
GIPI	R&B-M	1250	BA_Pop Shuffle1_XS	4/4	1	94			:
GIPI	R&B-M	1251	MA_Pop Shuffle1_ES	4/4	4	94			:
GIPI	R&B-M	1252	MB_Pop Shuffle1_ES	4/4	4	94			:
GIPI	R&B-M	1253	MC_Pop Shuffle1_ES	4/4	4	94			:
GIPI	R&B-M	1254	FA_Pop Shuffle1_ES	4/4	1	94			:
GIPI	R&B-M	1255	FB_Pop Shuffle1_ES	4/4	1	94			:
GIPI	R&B-M	1256	FC_Pop Shuffle1_ES	4/4	1	94			:
GIPI	R&B-M	1257	BA_Pop Shuffle1_ES	4/4	1	94			:
GIPI	R&B-M	1258	MB_R&B Disco_ES	4/4	2	110			Mute Guitar
GIPI	R&B-M	1259	MC_R&B Disco_ES	4/4	2	110			:
GIPI	R&B-M	1260	MD_R&B Disco_ES	4/4	2	110			:
GIPI	R&B-M	1261	FA_R&B Disco_ES	4/4	1	110			:
GIPI	R&B-M	1262	FB_R&B Disco_ES	4/4	2	110			:
GIPI	R&B-M	1263	MA_New R&B 2	4/4	1	97			Acoustic Guitar
GIPI	R&B-M	1264	MB_New R&B 2	4/4	1	123			:
GIPI	R&B-M	1265	MC_New R&B 2	4/4	1	97			:
GIPI	R&B-M	1266	IA_New R&B 2_ES	4/4	2	97			:
GIPI	R&B-M	1267	FA_New R&B 2	4/4	1	97			:
GIPI	R&B-M	1268	FB_New R&B 2	4/4	1	97			:
GIPI	R&B-M	1269	MA_New R&B 3	4/4	2	90			:
GIPI	R&B-M	1270	MB_New R&B 3	4/4	2	90			:
GIPI	R&B-M	1271	MC_New R&B 3_ES	4/4	2	90			:
GIPI	R&B-M	1272	MD_New R&B 3	4/4	2	90			:
GIPI	R&B-M	1273	MA_Pop R&B_XS	4/4	4	67			"Hip-Hop Nylon Guitar"
GIPI	R&B-M	1274	MB_Pop R&B_XS	4/4	4	67			:
GIPI	R&B-M	1275	MC_Pop R&B_XS	4/4	4	67			:
GIPI	R&B-M	1276	FA_Pop R&B_XS	4/4	1	67			:
GIPI	R&B-M	1277	FB_Pop R&B_XS	4/4	1	67			:
GIPI	R&B-M	1278	FC_Pop R&B_XS	4/4	1	67			:
GIPI	R&B-M	1279	MA_H-R&B Pop_XS	4/4	4	140			Acoustic Guitar
GIPI	R&B-M	1280	MB_H-R&B Pop_XS	4/4	4	140			:
GIPI	R&B-M	1281	MC_H-R&B Pop_XS	4/4	4	140			:
GIPI	R&B-M	1282	FA_H-R&B Pop_XS	4/4	1	140			:
GIPI	R&B-M	1283	MD_6/8 R&B	4/4	2	61			Clean Guitar
GIPI	R&B-M	1284	FA_6/8 R&B	4/4	1	61			:
GIPI	R&B-M	1285	FB_6/8 R&B	4/4	1	61			:
GIPI	R&B-M	1286	FC_6/8 R&B	4/4	2	61			:
GIPI	R&B-M	1287	MA_Smooth 1	4/4	2	115			Acoustic Guitar
GIPI	R&B-M	1288	MB_Smooth 1	4/4	2	115			:
GIPI	R&B-M	1289	MC_Smooth 1	4/4	2	115			:
GIPI	R&B-M	1290	MD_Smooth 1	4/4	2	115			:
GIPI	R&B-M	1291	IA_Smooth 1	4/4	1	115			:
GIPI	R&B-M	1292	FA_Smooth 1	4/4	1	115			:
GIPI	R&B-M	1293	FB_Smooth 1	4/4	1	115			:
GIPI	R&B-M	1294	FC_Smooth 1	4/4	2	115			:
GIPI	R&B-M	1295	MA1_Flip Hop 1	4/4	1	132			Clean Guitar
GIPI	R&B-M	1296	MB1_Flip Hop 1	4/4	2	132			:
GIPI	R&B-M	1297	MC1_Flip Hop 1	4/4	2	132			Mute Guitar
GIPI	R&B-M	1298	MD1_Flip Hop 1	4/4	2	132			:
GIPI	R&B-M	1299	FA1_Flip Hop 1	4/4	1	132			:
GIPI	R&B-M	1300	FB1_Flip Hop 1	4/4	1	132			:
GIPI	R&B-M	1301	FC2_Flip Hop 1	4/4	1	132			Acoustic Guitar
GIPI	R&B-M	1302	FA2_Flip Hop 1_ES	4/4	1	132			:
GIPI	R&B-M	1303	FB2_Flip Hop 1	4/4	2	132			:
GIPI	R&B-M	1304	MA_New Gospel_ES	4/4	2	90			Mute Guitar
GIPI	R&B-M	1305	MB_New Gospel_ES	4/4	2	90			:
GIPI	R&B-M	1306	MC_New Gospel_ES	4/4	2	90			:
GIPI	R&B-M	1307	MD_New Gospel_ES	4/4	2	90			:
GIPI	R&B-M	1308	IA_New Gospel_ES	4/4	1	90			:
GIPI	R&B-M	1309	FA_New Gospel_ES	4/4	1	90			:
GIPI	R&B-M	1310	FB_New Gospel_ES	4/4	1	90			:
GIPI	R&B-M	1311	FC_New Gospel_ES	4/4	2	90			:
GIPI	R&B-C	1312	MA_Soul 2	4/4	1	120			Clean Guitar
GIPI	R&B-C	1313	MB_Soul 2	4/4	1	120			:
GIPI	R&B-C	1314	MC_Soul 2	4/4	1	120			:
GIPI	R&B-C	1315	MD_Soul 2	4/4	4	120			:
GIPI	R&B-C	1316	FC_Soul 2	4/4	4	120			:
GIPI	Funk	1317</							

Arpeggio Type List

Main Category	Sub Category	ARP No.	ARP Name	Time Signature	Length	Original Tempo	Accent	Random SFX	Voice Type
GIPI	Funk	1323	FC_Funk 3	4/4	2	132			Clean Guitar
GIPI	Funk	1324	MA_Cool Funk_ES	4/4	2	96			:
GIPI	Funk	1325	MB_Cool Funk	4/4	1	96			:
GIPI	Funk	1326	MD_Cool Funk	4/4	2	96			:
GIPI	Funk	1327	IA_Cool Funk	4/4	2	96			:
GIPI	Funk	1328	FC_Cool Funk	4/4	1	96			:
GIPI	Funk	1329	MA_Jazz Funk 2	4/4	2	120			:
GIPI	Funk	1330	MB_Jazz Funk 2	4/4	2	120			:
GIPI	Funk	1331	MC_Jazz Funk 2	4/4	1	120			:
GIPI	Funk	1332	MD_Jazz Funk 2	4/4	2	120			:
GIPI	Funk	1333	IA_Jazz Funk 2	4/4	2	120			:
GIPI	Funk	1334	FB_Jazz Funk 2	4/4	1	120			:
GIPI	Funk	1335	FC_Jazz Funk 2	4/4	1	120			:
GIPI	Funk	1336	MA_Funky1	4/4	2	120			:
GIPI	Funk	1337	MA_Funky2	4/4	2	120			:
GIPI	Funk	1338	MA_Funky3	4/4	2	120			:
GIPI	Funk	1339	MA_Funky4	4/4	1	120			:
GIPI	Funk	1340	MA_Funk Guitar	4/4	2	116			Mute Guitar
GIPI	Funk	1341	MA_CleanGuitrA1	4/4	2	120			Clean Guitar
GIPI	Funk	1342	MA_CleanGuitrA2	4/4	2	120			:
GIPI	Funk	1343	MA_CleanGuitrA3	4/4	2	120			:
GIPI	Funk	1344	MA_CleanGuitrA4	4/4	2	120			:
GIPI	Funk	1345	MA_CleanGuitrB1_ES	4/4	4	127			:
GIPI	Funk	1346	MA_CleanGuitrB2_ES	4/4	4	107			:
GIPI	Funk	1347	MA_CleanGuitrB3_ES	4/4	4	107			:
GIPI	Funk	1348	MA_CleanGuitrB4_ES	4/4	4	107			:
GIPI	Funk	1349	MA_CleanGuitrB5_ES	4/4	4	107			:
GIPI	Funk	1350	MA_News1	4/4	2	120			:
GIPI	Funk	1351	MA_News2	4/4	2	120			Mute Guitar
GIPI	Funk	1352	MA_Spanky	4/4	2	105			Clean Guitar
GIPI	House	1353	MA1_Retro Pop_ES	4/4	2	126			Acoustic Guitar
GIPI	House	1354	MA2_Retro Pop_ES	4/4	2	126			Clean Guitar
GIPI	House	1355	MA_Disco House	4/4	2	128			:
GIPI	House	1356	MB_Disco House	4/4	2	128			:
GIPI	House	1357	MC_Disco House	4/4	2	128			:
GIPI	House	1358	MD_Disco House	4/4	2	128			:
GIPI	House	1359	IA_Disco House	4/4	4	128			:
GIPI	House	1360	FA_Disco House	4/4	1	128			:
GIPI	House	1361	FB_Disco House	4/4	1	128			:
GIPI	House	1362	FC_Disco House	4/4	4	128			:
GIPI	D&B	1363	MA_Big Beat 1_ES	4/4	4	115			Od/Dist Guitar
GIPI	D&B	1364	MB_Big Beat 1_ES	4/4	4	115			:
GIPI	D&B	1365	MC_Big Beat 1_ES	4/4	4	115			:
GIPI	D&B	1366	FA_Big Beat 1_ES	4/4	1	115			:
GIPI	D&B	1367	FB_Big Beat 1_ES	4/4	1	115			:
GIPI	D&B	1368	FC_Big Beat 1_ES	4/4	1	115			:
GIPI	D&B	1369	BA_Big Beat 1_ES	4/4	1	115			:
GIPI	D&B	1370	MA_Big Beat 2_ES	4/4	4	145			:
GIPI	D&B	1371	MB_Big Beat 2_ES	4/4	8	145			:
GIPI	D&B	1372	MC_Big Beat 2_ES	4/4	4	145			:
GIPI	D&B	1373	FA_Big Beat 2_ES	4/4	1	145			:
GIPI	D&B	1374	FB_Big Beat 2_ES	4/4	1	145			:
GIPI	D&B	1375	FC_Big Beat 2_ES	4/4	1	145			:
GIPI	D&B	1376	BA_Big Beat 2_ES	4/4	2	145			:
GIPI	Chill	1377	MA1_Chill Out	4/4	2	79			Clean Guitar
GIPI	Chill	1378	MA2_Chill Out	4/4	1	79			Acoustic Guitar
GIPI	Chill	1379	MB2_Chill Out	4/4	2	79			:
GIPI	Chill	1380	MC2_Chill Out	4/4	2	79			:
GIPI	Chill	1381	MD2_Chill Out	4/4	2	79			:
GIPI	Jazz	1382	MA_AcousticJazz_ES	4/4	4	204			Clean Guitar
GIPI	Jazz	1383	MB_AcousticJazz_ES	4/4	4	204			:
GIPI	Jazz	1384	MC_AcousticJazz_ES	4/4	4	204			:
GIPI	Jazz	1385	MD_AcousticJazz_ES	4/4	4	204			:
GIPI	Jazz	1386	IA_AcousticJazz_ES	4/4	4	204			:
GIPI	Jazz	1387	FA_AcousticJazz_ES	4/4	1	204			:
GIPI	Jazz	1388	FB_AcousticJazz_ES	4/4	1	204			:
GIPI	Jazz	1389	FC_AcousticJazz_ES	4/4	4	204			:
GIPI	Jazz	1390	MA_Modern Jazz_XS	4/4	16	218			:
GIPI	Jazz	1391	MB_Modern Jazz_XS	4/4	16	218			:
GIPI	Jazz	1392	MC_Modern Jazz_XS	4/4	16	218			:
GIPI	Jazz	1393	FA_Modern Jazz_XS	4/4	1	218			:
GIPI	Jazz	1394	FB_Modern Jazz_XS	4/4	1	218			:
GIPI	Jazz	1395	FC_Modern Jazz_XS	4/4	1	218			:
GIPI	Jazz	1396	BA_Modern Jazz_XS	4/4	1	218			:
GIPI	Jazz	1397	EA_Modern Jazz_XS	4/4	6	218			:
GIPI	Jazz	1398	EB_Modern Jazz_XS	4/4	7	218			:
GIPI	Jazz	1399	MA_R&R Shuffle_XS	4/4	4	192			:
GIPI	Jazz	1400	MB_R&R Shuffle_XS	4/4	4	192			:
GIPI	Jazz	1401	MC_R&R Shuffle_XS	4/4	4	192			:
GIPI	Jazz	1402	FA_R&R Shuffle_XS	4/4	1	192			:
GIPI	Jazz	1403	FB_R&R Shuffle_XS	4/4	1	192			:
GIPI	Jazz	1404	FC_R&R Shuffle_XS	4/4	1	192			:
GIPI	Jazz	1405	BA_R&R Shuffle_XS	4/4	1	192			:

Main Category	Sub Category	ARP No.	ARP Name	Time Signature	Length	Original Tempo	Accent	Random SFX	Voice Type
GIPI	Jazz	1406	EA_R&R Shuffle_XS	4/4	5	192			Clean Guitar
GIPI	Jazz	1407	EB_R&R Shuffle_XS	4/4	5	192			:
GIPI	Jazz	1408	MA_Slow Blues 2_XS	4/4	4	72			"Mid Drive (2handGtr)"
GIPI	Jazz	1409	MB_Slow Blues 2_XS	4/4	4	72			:
GIPI	Jazz	1410	MC_Slow Blues 2_XS	4/4	4	72			:
GIPI	Jazz	1411	FA_Slow Blues 2_XS	4/4	1	72			:
GIPI	Jazz	1412	FB_Slow Blues 2_XS	4/4	1	72			:
GIPI	Jazz	1413	FC_Slow Blues 2_XS	4/4	1	72			:
GIPI	Jazz	1414	BA_Slow Blues 2_XS	4/4	1	72			:
GIPI	Jazz	1415	MA_Slow Blues 2_ES	4/4	4	72			:
GIPI	Jazz	1416	MB_Slow Blues 2_ES	4/4	4	72			:
GIPI	Jazz	1417	MC_Slow Blues 2_ES	4/4	4	72			:
GIPI	Jazz	1418	FA_Slow Blues 2_ES	4/4	1	72			:
GIPI	Jazz	1419	FB_Slow Blues 2_ES	4/4	1	72			:
GIPI	Jazz	1420	FC_Slow Blues 2_ES	4/4	1	72			:
GIPI	Jazz	1421	BA_Slow Blues 2_ES	4/4	1	72			:
GIPI	Latin	1422	MA_Montuno_ES	4/4	2	100			Acoustic Guitar
GIPI	Latin	1423	MB_Montuno_ES	4/4	2	100			:
GIPI	Latin	1424	MC_Montuno/1_ES	4/4	2	100			:
GIPI	Latin	1425	MC_Montuno/2_ES	4/4	4	100			:
GIPI	Latin	1426	MD_Montuno/1_ES	4/4	2	100			:
GIPI	Latin	1427	MD_Montuno/2_ES	4/4	2	100			:
GIPI	Latin	1428	IA_Montuno_ES	4/4	2	100			:
GIPI	Latin	1429	FA_Montuno_ES	4/4	1	100			:
GIPI	Latin	1430	FC_Montuno_ES	4/4	1	100			:
GIPI	Latin	1431	MA_Samba	4/4	4	120			:
GIPI	Latin	1432	MB_Samba	4/4	4	120			:
GIPI	Latin	1433	MD_Samba	4/4	4	120			:
GIPI	Latin	1434	IA_Samba	4/4	2	120			:
GIPI	Latin	1435	MA_Bomba_XS	4/4	4	99			:
GIPI	Latin	1436	MB_Bomba_XS	4/4	4	99			:
GIPI	Latin	1437	MC_Bomba_XS	4/4	4	99			:
GIPI	Latin	1438	FA_Bomba_XS	4/4	1	99			:
GIPI	Latin	1439	FB_Bomba_XS	4/4	1	99			:
GIPI	Latin	1440	FC_Bomba_XS	4/4	1	99			:
GIPI	Latin	1441	BA_Bomba_XS	4/4	1	99			:
GIPI	Latin	1442	EA_Bomba_XS	4/4	3	99			:
GIPI	Latin	1443	EB_Bomba_XS	4/4	3	99			:
GIPI	Latin	1444	MA_Bomba_ES	4/4	4	99			:
GIPI	Latin	1445	MB_Bomba	4/4	4	99			:
GIPI	Latin	1446	MC_Bomba_ES	4/4	4	99			:
GIPI	Latin	1447	FA_Bomba	4/4	1	99			:
GIPI	Latin	1448	FB_Bomba	4/4	1	99			:
GIPI	Latin	1449	FC_Bomba_ES	4/4	1	99			:
GIPI	Latin	1450	BA_Bomba	4/4	1	99			:
GIPI	Latin	1451	MA_Guaguanco_XS	4/4	4	120			:
GIPI	Latin	1452	MB_Guaguanco_XS	4/4	4	120			:
GIPI	Latin	1453	MC_Guaguanco_XS	4/4	4	120			:
GIPI	Latin	1454	FA_Guaguanco_XS	4/4	1	120			:
GIPI	Latin	1455	FB_Guaguanco_XS	4/4	1	120			:
GIPI	Latin	1456	FC_Guaguanco_XS	4/4	1	120			:
GIPI	Latin	1457	BA_Guaguanco_XS	4/4	1	120			:
GIPI	Latin	1458	EA_Guaguanco_XS	4/4	3	120			:
GIPI	Latin	1459	EB_Guaguanco_XS	4/4	3	120			:
GIPI	Latin	1460	MC1_Latin Rock	4/4	2	120			Clean Guitar
GIPI	Latin	1461	FB1_Latin Rock	4/4	1	120			:
GIPI	Latin	1462	MB2_Latin Rock	4/4	1	120			Acoustic Guitar
GIPI	Latin	1463	MC2_Latin Rock	4/4	2	120			:
GIPI	Latin	1464	MA_LatinPhrase1	4/4	2	120			:
GIPI	Latin	1465	MA_LatinPhrase2	4/4	2	120			:
GIPI	Latin	1466	MA_LatinPhrase3	4/4	1	120			:
GIPI	Latin	1467	MA_SteelGuitar1_ES	4/4	4	120			:
GIPI	Latin	1468	MA_SteelGuitar2_ES	4/4	4	120			:
GIPI	Latin	1469	MA_SteelGuitar3_ES	4/4	4	120			:
GIPI	Latin	1470	MA_SteelGuitar4_ES	4/4	4	120			:
GIPI	World	1471	MA1_Reggae 1	4/4	1	102			Clean Guitar
GIPI	World	1472	MB1_Reggae 1	4/4	2	102			:
GIPI	World	1473	MD1_Reggae 1	4/4	2	90			:
GIPI	World	1474	IA1_Reggae 1	4/4	1	102			:
GIPI	World	1475	FC1_Reggae 1	4/4	2	96			:
GIPI	World	1476	MA2_Reggae 1	4/4	4	102			Mute Guitar
GIPI	World	1477	MB2_Reggae 1	4/4	4	102			:
GIPI	World	1478	MA_Reggae 2	4/4	2	92			Clean Guitar
GIPI	World	1479	MB_Reggae 2	4/4	1	92			:
GIPI	World	1480	IA_Reggae 2	4/4	2	92			:
GIPI	World	1481	MA1_Spanish Pop	4/4	2	120			Acoustic Guitar
GIPI	World	1482	MB1_Spanish Pop	4/4	2	120			:
GIPI	World	1483	MD1_Spanish Pop	4/4	2	120			:
GIPI	World	1484	FA1_Spanish Pop	4/4	1	120			:
GIPI	World	1485	FB1_Spanish Pop	4/4	1	120			:
GIPI	World	1486	IA2_Spanish Pop	4/4	4	120			:
GIPI	World	1487	FC2_Spanish Pop	4/4	3	120			:
GIPI	World	1488	MA3_Spanish Pop	4/4	2	120			:

Arpeggio Type List

Main Category	Sub Category	ARP No.	ARP Name	Time Signature	Length	Original Tempo	Accent	Random SFX	Voice Type
GIPI	World	1489	MB3_Spanish Pop	4/4	2	120			Acoustic Guitar
GIPI	World	1490	MC3_Spanish Pop	4/4	2	120			:
GIPI	World	1491	MD3_Spanish Pop	4/4	2	120			:
GIPI	World	1492	IA3_Spanish Pop	4/4	4	120			:
GIPI	World	1493	FA3_Spanish Pop	4/4	1	120			:
GIPI	World	1494	FB3_Spanish Pop	4/4	1	120			:
GIPI	World	1495	MA_ModBluegrass_XS	4/4	4	121			Banjo
GIPI	World	1496	MB_ModBluegrass_XS	4/4	4	121			:
GIPI	World	1497	MC_ModBluegrass_XS	4/4	4	121			:
GIPI	World	1498	FA_ModBluegrass_XS	4/4	1	121			:
GIPI	World	1499	FB_ModBluegrass_XS	4/4	1	121			:
GIPI	World	1500	FC_ModBluegrass_XS	4/4	1	121			:
GIPI	World	1501	BA_ModBluegrass_XS	4/4	1	121			:
GIPI	World	1502	EA_ModBluegrass_XS	4/4	6	121			:
GIPI	World	1503	MB1_Turkish_ES	4/4	2	105			Kotoun
GIPI	World	1504	MD1_Turkish_ES	9/8	2	125			:
GIPI	World	1505	ME1_Turkish_ES	4/4	2	105			:
GIPI	World	1506	IA1_Turkish_ES	4/4	2	86			:
GIPI	World	1507	MF2_Turkish_ES	4/4	2	105			Kanun
GIPI	World	1508	MA3_Turkish_ES	4/4	2	105			Bouzouki
GIPI	World	1509	MA_Sitar_ES	4/4	2	140			Sitar
GIPI	World	1510	MB_Sitar_ES	4/4	2	140			:
GIPI	World	1511	MC_Sitar_ES	4/4	2	140			:
GIPI	World	1512	MD_Sitar_ES	4/4	2	140			:
GIPI	World	1513	ME_Sitar_ES	4/4	2	140			:
GIPI	World	1514	MA_Sitar Gliss_ES	4/4	3	120			:
GIPI	World	1515	MB_Sitar Gliss_ES	4/4	3	120			:
GIPI	World	1516	MA_Berimbau_ES	4/4	4	110			"Berimbau"
GIPI	World	1517	MB_Berimbau_ES	4/4	2	110			:
GIPI	World	1518	MC_Berimbau_ES	4/4	4	110			:
GIPI	World	1519	MD_Berimbau_ES	4/4	4	110			:
GIPI	World	1520	ME_Berimbau_ES	4/4	2	110			:
GIPI	Genrl	1521	MA_Strum1	4/4	1	120			Acoustic Guitar
GIPI	Genrl	1522	MA_Strum2	4/4	2	120			:
GIPI	Genrl	1523	MA_Strum3	4/4	4	120			:
GIPI	Genrl	1524	MA_Strum4	4/4	2	120			:
GIPI	Genrl	1525	MA_Strum5	4/4	2	120			:
GIPI	Genrl	1526	MA_Strum6	4/4	2	120			:
GIPI	Genrl	1527	MA_Strum7	4/4	2	120			:
GIPI	Genrl	1528	MA_Strum8	4/4	2	120			:
GIPI	Genrl	1529	MA_Strum9	4/4	2	120			:
GIPI	Genrl	1530	MA_Strum10	4/4	2	120			:
GIPI	Genrl	1531	MA_Guitar Arp1	4/4	1	120			Sitar
GIPI	Genrl	1532	MA_Guitar Arp2	4/4	1	120			:
GIPI	Genrl	1533	MA_Guitar Arp3	4/4	1	120			:
GIPI	Genrl	1534	MA_Guitar Arp4	4/4	1	120			:
GIPI	Genrl	1535	MA_RolliArp	4/4	4	60			:
GIPI	Genrl	1536	Tremolo	4/4	1	100			:
GIPI	Genrl	1537	Lick1	4/4	4	120			Od/Dist Guitar
GIPI	Genrl	1538	Lick2	4/4	4	120			:
GIPI	Genrl	1539	Lick3	4/4	4	120			:
GIPI	Genrl	1540	Lick4	4/4	2	120			:
GIPI	Genrl	1541	Lick5	4/4	4	120			:
GIPI	Genrl	1542	Lick6	4/4	1	120			:
GIMG	Rock	1543	MA1_StandardRock_XS	4/4	4	131		O	"Mega 60s Tube Tone"
GIMG	Rock	1544	MB1_StandardRock_XS	4/4	4	131		O	:
GIMG	Rock	1545	MC1_StandardRock_XS	4/4	4	131		O	:
GIMG	Rock	1546	FA1_StandardRock_XS	4/4	1	131		O	:
GIMG	Rock	1547	FB1_StandardRock_XS	4/4	1	131		O	:
GIMG	Rock	1548	FC1_StandardRock_XS	4/4	1	131		O	:
GIMG	Rock	1549	BA1_StandardRock_XS	4/4	1	131		O	:
GIMG	Rock	1550	EA1_StandardRock_XS	4/4	4	131		O	:
GIMG	Rock	1551	EB1_StandardRock_XS	4/4	6	131		O	:
GIMG	Rock	1552	MA2_StandardRock_XS	4/4	4	131		O	"Mega 1coil Slap Dist"
GIMG	Rock	1553	MB2_StandardRock_XS	4/4	4	131		O	:
GIMG	Rock	1554	MC2_StandardRock_XS	4/4	4	131		O	:
GIMG	Rock	1555	FA2_StandardRock_XS	4/4	1	131		O	:
GIMG	Rock	1556	FB2_StandardRock_XS	4/4	1	131		O	:
GIMG	Rock	1557	FC2_StandardRock_XS	4/4	1	131		O	:
GIMG	Rock	1558	BA2_StandardRock_XS	4/4	1	131		O	:
GIMG	Rock	1559	EA2_StandardRock_XS	4/4	4	131		O	:
GIMG	Rock	1560	EB2_StandardRock_XS	4/4	6	131		O	:
GIMG	Rock	1561	MA1_Ovdr PowerRk_XS	4/4	4	120		O	"Mega Ovdr Distortion"
GIMG	Rock	1562	MB1_Ovdr PowerRk_XS	4/4	4	120		O	:
GIMG	Rock	1563	MC1_Ovdr PowerRk_XS	4/4	4	120		O	:
GIMG	Rock	1564	FA1_Ovdr PowerRk_XS	4/4	1	120		O	:
GIMG	Rock	1565	FB1_Ovdr PowerRk_XS	4/4	1	120		O	:
GIMG	Rock	1566	FC1_Ovdr PowerRk_XS	4/4	1	120		O	:
GIMG	Rock	1567	BA1_Ovdr PowerRk_XS	4/4	1	120		O	:
GIMG	Rock	1568	EA1_Ovdr PowerRk_XS	4/4	4	120		O	:
GIMG	Rock	1569	EB1_Ovdr PowerRk_XS	4/4	7	120		O	:
GIMG	Rock	1570	MA1_Ovdr PowerRk	4/4	4	120		O	:
GIMG	Rock	1571	MB1_Ovdr PowerRk	4/4	4	120		O	:

Main Category	Sub Category	ARP No.	ARP Name	Time Signature	Length	Original Tempo	Accent	Random SFX	Voice Type
GIMG	Rock	1572	MC1_Ovdr PowerRk	4/4	4	120		O	"Mega Ovdr Distortion"
GIMG	Rock	1573	FA1_Ovdr PowerRk	4/4	1	120		O	:
GIMG	Rock	1574	FB1_Ovdr PowerRk	4/4	1	120		O	:
GIMG	Rock	1575	FC1_Ovdr PowerRk	4/4	1	120		O	:
GIMG	Rock	1576	BA1_Ovdr PowerRk	4/4	1	120		O	:
GIMG	Rock	1577	MA2_Ovdr PowerRk_XS	4/4	4	120		O	"Mega Ovdr Fuzz"
GIMG	Rock	1578	MB2_Ovdr PowerRk_XS	4/4	4	120		O	:
GIMG	Rock	1579	MC2_Ovdr PowerRk_XS	4/4	4	120		O	:
GIMG	Rock	1580	FA2_Ovdr PowerRk_XS	4/4	1	120		O	:
GIMG	Rock	1581	FB2_Ovdr PowerRk_XS	4/4	1	120		O	:
GIMG	Rock	1582	FC2_Ovdr PowerRk_XS	4/4	1	120		O	:
GIMG	Rock	1583	BA2_Ovdr PowerRk_XS	4/4	1	120		O	:
GIMG	Rock	1584	EA2_Ovdr PowerRk_XS	4/4	4	120		O	:
GIMG	Rock	1585	EB2_Ovdr PowerRk_XS	4/4	7	120		O	:
GIMG	Rock	1586	MA2_Ovdr PowerRk	4/4	4	120		O	:
GIMG	Rock	1587	MB2_Ovdr PowerRk	4/4	4	120		O	:
GIMG	Rock	1588	MC2_Ovdr PowerRk	4/4	4	120		O	:
GIMG	Rock	1589	FA2_Ovdr PowerRk	4/4	1	120		O	:
GIMG	Rock	1590	FB2_Ovdr PowerRk	4/4	1	120		O	:
GIMG	Rock	1591	FC2_Ovdr PowerRk	4/4	1	120		O	:
GIMG	Rock	1592	BA2_Ovdr PowerRk	4/4	1	120		O	:
GIMG	Rock	1593	MA_ContempRock_XS	4/4	4	126		O	"Mega 1coil Slap Dist"
GIMG	Rock	1594	MB_ContempRock_XS	4/4	4	126		O	:
GIMG	Rock	1595	MC_ContempRock_XS	4/4	4	126		O	:
GIMG	Rock	1596	FA_ContempRock_XS	4/4	1	126		O	:
GIMG	Rock	1597	FB_ContempRock_XS	4/4	1	126		O	:
GIMG	Rock	1598	FC_ContempRock_XS	4/4	1	126		O	:
GIMG	Rock	1599	BA_ContempRock_XS	4/4	1	126		O	:
GIMG	Rock	1600	EA_ContempRock_XS	4/4	4	126		O	:
GIMG	Rock	1601	EB_ContempRock_XS	4/4	4	126		O	:
GIMG	Rock	1602	MA1_Hard Rock_XS	4/4	4	120		O	"Mega 60s Tube Tone"
GIMG	Rock	1603	MB1_Hard Rock_XS	4/4	4	120		O	:
GIMG	Rock	1604	MC1_Hard Rock_XS	4/4	4	120		O	:
GIMG	Rock	1605	FA1_Hard Rock_XS	4/4	1	120		O	:
GIMG	Rock	1606	FB1_Hard Rock_XS	4/4	1	120		O	:
GIMG	Rock	1607	FC1_Hard Rock_XS	4/4	1	120		O	:
GIMG	Rock	1608	BA1_Hard Rock_XS	4/4	1	120		O	:
GIMG	Rock	1609	EA1_Hard Rock_XS	4/4	3	120		O	:
GIMG	Rock	1610	EB1_Hard Rock_XS	4/4	6	120		O	:
GIMG	Rock	1611	MA2_Hard Rock_XS	4/4	4	120		O	:
GIMG	Rock	1612	MB2_Hard Rock_XS	4/4	4	120		O	:
GIMG	Rock	1613	MC2_Hard Rock_XS	4/4	4	120		O	:
GIMG	Rock	1614	FA2_Hard Rock_XS	4/4	1	120		O	:
GIMG	Rock	1615	FB2_Hard Rock_XS	4/4	1	120		O	:
GIMG	Rock	1616	FC2_Hard Rock_XS	4/4	1	120		O	:
GIMG	Rock	1617	BA2_Hard Rock_XS	4/4	1	120		O	:
GIMG	Rock	1618	EA2_Hard Rock_XS	4/4	3	120		O	:
GIMG	Rock	1619	EB2_Hard Rock_XS	4/4	6	120		O	:
GIMG	Rock	1620	MA1_Blues Rock_XS	4/4	4	120		O	"Mega 60s Dist Stack"
GIMG	Rock	1621	MB1_Blues Rock_XS	4/4	4	120		O	:
GIMG	Rock	1622	MC1_Blues Rock_XS	4/4	4	120		O	:
GIMG	Rock	1623	FA1_Blues Rock_XS	4/4	1	120		O	:
GIMG	Rock	1624	FB1_Blues Rock_XS	4/4	1	120		O	:
GIMG	Rock	1625	FC1_Blues Rock_XS	4/4	1	120		O	:
GIMG	Rock	1626	BA1_Blues Rock_XS	4/4	1	120		O	:
GIMG	Rock	1627	EA1_Blues Rock_XS	4/4	3	120		O	:
GIMG	Rock	1628	EB1_Blues Rock_XS	4/4	5	120		O	:
GIMG	Rock	1629	MA2_Blues Rock_XS	4/4	4	120		O	"Mega 60s Tube Tone"
GIMG	Rock	1630	MB2_Blues Rock_XS	4/4	4	120		O	:
GIMG	Rock	1631	MC2_Blues Rock_XS	4/4	4	120		O	:
GIMG	Rock	1632	FA2_Blues Rock_XS	4/4	1	120		O	:
GIMG	Rock	1633	FB2_Blues Rock_XS	4/4	1	120		O	:
GIMG	Rock	1634	FC2_Blues Rock_XS	4/4	1	120		O	:
GIMG	Rock	1635	BA2_Blues Rock_XS	4/4	1	120		O	:
GIMG	Rock	1636	EA2_Blues Rock_XS	4/4	3	120		O	:
GIMG	Rock	1637	EB2_Blues Rock_XS	4/4	5	120		O	:
GIMG	Rock	1638	MA1_RockShuffle_XS	4/4	4	121		O	"Mega 1coil Old R&R"
GIMG	Rock	1639	MB1_RockShuffle_XS	4/4	4	121		O	:
GIMG	Rock	1640	MC1_RockShuffle_XS	4/4	4	121		O	:
GIMG	Rock	1641	FA1_RockShuffle_XS	4/4	1	121		O	:
GIMG	Rock	1642	FB1_RockShuffle_XS	4/4	1	121		O	:
GIMG	Rock	1643	FC1_RockShuffle_XS	4/4	1	121		O	:
GIMG	Rock	1644	BA1_RockShuffle_XS	4/4	1	121		O	:
GIMG	Rock	1645	EA1_RockShuffle_XS	4/4	6	121		O	:
GIMG	Rock	1646	MA2_RockShuffle_XS	4/4	4	121		O	"Mega 60s Blues Tone"
GIMG	Rock	1647	MB2_RockShuffle_XS	4/4	4	121		O	:
GIMG	Rock	1648	MC2_RockShuffle_XS	4/4	4	121		O	:
GIMG	Rock	1649	FA2_RockShuffle_XS	4/4	1	121		O	:
GIMG	Rock	1650	FB2_RockShuffle_XS	4/4	1	121		O	:
GIMG	Rock	1651	FC2_RockShuffle_XS	4/4	1	121		O	:
GIMG	Rock	1652	BA2_RockShuffle_XS	4/4	1	121	</		

Arpeggio Type List

Main Category	Sub Category	ARP No.	ARP Name	Time Signature	Length	Original Tempo	Accent	Random SFX	Voice Type
GIMG	Rock	1655	MB_Rock & Roll_XS	4/4	4	172		○	"Mega 60s Clean"
GIMG	Rock	1656	MC_Rock & Roll_XS	4/4	4	172		○	:
GIMG	Rock	1657	FA_Rock & Roll_XS	4/4	1	172		○	:
GIMG	Rock	1658	FB_Rock & Roll_XS	4/4	1	172		○	:
GIMG	Rock	1659	FC_Rock & Roll_XS	4/4	1	172		○	:
GIMG	Rock	1660	BA_Rock & Roll_XS	4/4	1	172		○	:
GIMG	Rock	1661	EA_Rock & Roll_XS	4/4	5	172		○	:
GIMG	Rock	1662	EB_Rock & Roll_XS	4/4	6	172		○	:
GIMG	PopRk	1663	MA_Guitar Pop 1_XS	4/4	4	100		○	"Mega 60s ChorusCombo"
GIMG	PopRk	1664	MB_Guitar Pop 1_XS	4/4	4	100		○	:
GIMG	PopRk	1665	MC_Guitar Pop 1_XS	4/4	4	100		○	:
GIMG	PopRk	1666	FA_Guitar Pop 1_XS	4/4	1	100		○	:
GIMG	PopRk	1667	FB_Guitar Pop 1_XS	4/4	1	100		○	:
GIMG	PopRk	1668	FC_Guitar Pop 1_XS	4/4	1	100		○	:
GIMG	PopRk	1669	BA_Guitar Pop 1_XS	4/4	1	100		○	:
GIMG	PopRk	1670	EA_Guitar Pop 1_XS	4/4	3	100		○	:
GIMG	PopRk	1671	EB_Guitar Pop 1_XS	4/4	3	100		○	:
GIMG	PopRk	1672	MA1_Acoustic Pop_XS	4/4	4	110		○	"Mega Steel"
GIMG	PopRk	1673	MB1_Acoustic Pop_XS	4/4	4	110		○	:
GIMG	PopRk	1674	MC1_Acoustic Pop_XS	4/4	4	110		○	:
GIMG	PopRk	1675	FA1_Acoustic Pop_XS	4/4	1	110		○	:
GIMG	PopRk	1676	FB1_Acoustic Pop_XS	4/4	1	110		○	:
GIMG	PopRk	1677	FC1_Acoustic Pop_XS	4/4	1	110		○	:
GIMG	PopRk	1678	MA2_Acoustic Pop_XS	4/4	4	110		○	"Mega 60s Clean"
GIMG	PopRk	1679	MB2_Acoustic Pop_XS	4/4	4	110		○	:
GIMG	PopRk	1680	MC2_Acoustic Pop_XS	4/4	4	110		○	:
GIMG	PopRk	1681	FA2_Acoustic Pop_XS	4/4	1	110		○	:
GIMG	PopRk	1682	FB2_Acoustic Pop_XS	4/4	1	110		○	:
GIMG	PopRk	1683	FC2_Acoustic Pop_XS	4/4	1	110		○	:
GIMG	PopRk	1684	MA1_Worship Slow_XS	4/4	4	75		○	"Mega Steel"
GIMG	PopRk	1685	MB1_Worship Slow_XS	4/4	4	75		○	:
GIMG	PopRk	1686	MC1_Worship Slow_XS	4/4	4	75		○	:
GIMG	PopRk	1687	FA1_Worship Slow_XS	4/4	1	75		○	:
GIMG	PopRk	1688	FB1_Worship Slow_XS	4/4	1	75		○	:
GIMG	PopRk	1689	FC1_Worship Slow_XS	4/4	1	75		○	:
GIMG	PopRk	1690	BA1_Worship Slow_XS	4/4	1	75		○	:
GIMG	PopRk	1691	EA1_Worship Slow_XS	4/4	4	75		○	:
GIMG	PopRk	1692	EB1_Worship Slow_XS	4/4	4	75		○	:
GIMG	PopRk	1693	MA2_Worship Slow_XS	4/4	4	75		○	"Mega Nylon"
GIMG	PopRk	1694	MB2_Worship Slow_XS	4/4	4	75		○	:
GIMG	PopRk	1695	MC2_Worship Slow_XS	4/4	4	75		○	:
GIMG	PopRk	1696	FA2_Worship Slow_XS	4/4	1	75		○	:
GIMG	PopRk	1697	FB2_Worship Slow_XS	4/4	1	75		○	:
GIMG	PopRk	1698	FC2_Worship Slow_XS	4/4	1	75		○	:
GIMG	PopRk	1699	BA2_Worship Slow_XS	4/4	1	75		○	:
GIMG	PopRk	1700	MA1_Worship Med_XS	4/4	8	140		○	"Mega Steel"
GIMG	PopRk	1701	MB1_Worship Med_XS	4/4	4	140		○	:
GIMG	PopRk	1702	MC1_Worship Med_XS	4/4	4	140		○	:
GIMG	PopRk	1703	FA1_Worship Med_XS	4/4	1	140		○	:
GIMG	PopRk	1704	FB1_Worship Med_XS	4/4	1	140		○	:
GIMG	PopRk	1705	FC1_Worship Med_XS	4/4	1	140		○	:
GIMG	PopRk	1706	BA1_Worship Med_XS	4/4	1	140		○	:
GIMG	PopRk	1707	EA1_Worship Med_XS	4/4	4	140		○	:
GIMG	PopRk	1708	EB1_Worship Med_XS	4/4	4	140		○	:
GIMG	PopRk	1709	MA2_Worship Med_XS	4/4	8	140		○	"Mega Nylon"
GIMG	PopRk	1710	MB2_Worship Med_XS	4/4	4	140		○	:
GIMG	PopRk	1711	MC2_Worship Med_XS	4/4	4	140		○	:
GIMG	PopRk	1712	FA2_Worship Med_XS	4/4	1	140		○	:
GIMG	PopRk	1713	FB2_Worship Med_XS	4/4	1	140		○	:
GIMG	PopRk	1714	FC2_Worship Med_XS	4/4	1	140		○	:
GIMG	PopRk	1715	BA2_Worship Med_XS	4/4	1	140		○	:
GIMG	PopRk	1716	EA2_Worship Med_XS	4/4	4	140		○	:
GIMG	PopRk	1717	EB2_Worship Med_XS	4/4	4	140		○	:
GIMG	PopRk	1718	MA_Worship Fast_XS	4/4	8	114		○	"Mega Steel"
GIMG	PopRk	1719	MB_Worship Fast_XS	4/4	4	114		○	:
GIMG	PopRk	1720	MC_Worship Fast_XS	4/4	4	114		○	:
GIMG	PopRk	1721	FA_Worship Fast_XS	4/4	1	114		○	:
GIMG	PopRk	1722	FB_Worship Fast_XS	4/4	1	114		○	:
GIMG	PopRk	1723	FC_Worship Fast_XS	4/4	1	114		○	:
GIMG	PopRk	1724	BA_Worship Fast_XS	4/4	1	114		○	:
GIMG	PopRk	1725	EA_Worship Fast_XS	4/4	4	114		○	:
GIMG	PopRk	1726	EB_Worship Fast_XS	4/4	2	114		○	:
GIMG	PopRk	1727	MA_New Country_XS	4/4	2	118		○	"Mega 60s Clean"
GIMG	PopRk	1728	MB_New Country_XS	4/4	4	118		○	:
GIMG	PopRk	1729	MC_New Country_XS	4/4	2	118		○	:
GIMG	PopRk	1730	FA_New Country_XS	4/4	1	118		○	:
GIMG	PopRk	1731	FB_New Country_XS	4/4	1	118		○	:
GIMG	PopRk	1732	FC_New Country_XS	4/4	1	118		○	:
GIMG	PopRk	1733	BA_New Country_XS	4/4	1	118		○	:
GIMG	PopRk	1734	EA_New Country_XS	4/4	4	118		○	:
GIMG	PopRk	1735	EB_New Country_XS	4/4	4	118		○	:
GIMG	PopRk	1736	MA_New Country	4/4	2	118		○	:
GIMG	PopRk	1737	MB_New Country	4/4	4	118		○	:

Main Category	Sub Category	ARP No.	ARP Name	Time Signature	Length	Original Tempo	Accent	Random SFX	Voice Type
GIMG	PopRk	1738	MC_New Country	4/4	2	118		○	"Mega 60s Clean"
GIMG	PopRk	1739	FA_New Country	4/4	1	118		○	:
GIMG	PopRk	1740	FB_New Country	4/4	1	118		○	:
GIMG	PopRk	1741	FC_New Country	4/4	1	118		○	:
GIMG	PopRk	1742	BA_New Country	4/4	1	118		○	:
GIMG	PopRk	1743	MA1_VintageGtPop_XS	4/4	4	148		○	"Mega Steel"
GIMG	PopRk	1744	MB1_VintageGtPop_XS	4/4	4	148		○	:
GIMG	PopRk	1745	MC1_VintageGtPop_XS	4/4	4	148		○	:
GIMG	PopRk	1746	FA1_VintageGtPop_XS	4/4	1	148		○	:
GIMG	PopRk	1747	FB1_VintageGtPop_XS	4/4	1	148		○	:
GIMG	PopRk	1748	FC1_VintageGtPop_XS	4/4	1	148		○	:
GIMG	PopRk	1749	BA1_VintageGtPop_XS	4/4	1	148		○	:
GIMG	PopRk	1750	EA1_VintageGtPop_XS	4/4	4	148		○	:
GIMG	PopRk	1751	EB1_VintageGtPop_XS	4/4	4	148		○	:
GIMG	PopRk	1752	MA2_VintageGtPop_XS	4/4	4	148		○	"Mega 60s Clean"
GIMG	PopRk	1753	MB2_VintageGtPop_XS	4/4	4	148		○	:
GIMG	PopRk	1754	MC2_VintageGtPop_XS	4/4	4	148		○	:
GIMG	PopRk	1755	FA2_VintageGtPop_XS	4/4	1	148		○	:
GIMG	PopRk	1756	FB2_VintageGtPop_XS	4/4	1	148		○	:
GIMG	PopRk	1757	FC2_VintageGtPop_XS	4/4	1	148		○	:
GIMG	PopRk	1758	BA2_VintageGtPop_XS	4/4	1	148		○	:
GIMG	PopRk	1759	EA2_VintageGtPop_XS	4/4	4	148		○	:
GIMG	PopRk	1760	EB2_VintageGtPop_XS	4/4	4	148		○	:
GIMG	PopRk	1761	MA1_WestCoastPop_XS	4/4	4	100		○	"Mega Steel"
GIMG	PopRk	1762	MB1_WestCoastPop_XS	4/4	4	100		○	:
GIMG	PopRk	1763	MC1_WestCoastPop_XS	4/4	4	100		○	:
GIMG	PopRk	1764	FA1_WestCoastPop_XS	4/4	1	100		○	:
GIMG	PopRk	1765	FB1_WestCoastPop_XS	4/4	1	100		○	:
GIMG	PopRk	1766	FC1_WestCoastPop_XS	4/4	1	100		○	:
GIMG	PopRk	1767	BA1_WestCoastPop_XS	4/4	1	100		○	:
GIMG	PopRk	1768	EA1_WestCoastPop_XS	4/4	4	100		○	:
GIMG	PopRk	1769	EB1_WestCoastPop_XS	4/4	4	100		○	:
GIMG	PopRk	1770	MA2_WestCoastPop_XS	4/4	4	100		○	"Mega 60s Tube Tone"
GIMG	PopRk	1771	MB2_WestCoastPop_XS	4/4	4	100		○	:
GIMG	PopRk	1772	MC2_WestCoastPop_XS	4/4	4	100		○	:
GIMG	PopRk	1773	FA2_WestCoastPop_XS	4/4	1	100		○	:
GIMG	PopRk	1774	FB2_WestCoastPop_XS	4/4	1	100		○	:
GIMG	PopRk	1775	FC2_WestCoastPop_XS	4/4	1	100		○	:
GIMG	PopRk	1776	BA2_WestCoastPop_XS	4/4	1	100		○	:
GIMG	PopRk	1777	EA2_WestCoastPop_XS	4/4	4	100		○	:
GIMG	PopRk	1778	EB2_WestCoastPop_XS	4/4	4	100		○	:
GIMG	PopRk	1779	MA1_Brit Pop_XS	4/4	2	86		○	"Mega Steel"
GIMG	PopRk	1780	MB1_Brit Pop_XS	4/4	2	86		○	:
GIMG	PopRk	1781	MC1_Brit Pop_XS	4/4	2	86		○	:
GIMG	PopRk	1782	FA1_Brit Pop_XS	4/4	1	86		○	:
GIMG	PopRk	1783	FB1_Brit Pop_XS	4/4	1	86		○	:
GIMG	PopRk	1784	FC1_Brit Pop_XS	4/4	1	86		○	:
GIMG	PopRk	1785	BA1_Brit Pop_XS	4/4	1	86		○	:
GIMG	PopRk	1786	EA1_Brit Pop_XS	4/4	4	86		○	:
GIMG	PopRk	1787	EB1_Brit Pop_XS	4/4	4	86		○	:
GIMG	PopRk	1788	MA1_Brit Pop	4/4	2	86		○	:
GIMG	PopRk	1789	MB1_Brit Pop	4/4	2	86		○	:
GIMG	PopRk	1790	MC1_Brit Pop	4/4	2	86		○	:
GIMG	PopRk	1791	FA1_Brit Pop	4/4	1	86		○	:
GIMG	PopRk	1792	FB1_Brit Pop	4/4	1	86		○	:
GIMG	PopRk	1793	FC1_Brit Pop	4/4	1	86		○	:
GIMG	PopRk	1794	BA1_Brit Pop	4/4	1	86		○	:
GIMG	PopRk	1795	MA2_Brit Pop_XS	4/4	2	86		○	"Mega 100t SlapClean"
GIMG	PopRk	1796	MB2_Brit Pop_XS	4/4	2	86		○	:
GIMG	PopRk	1797	MC2_Brit Pop_XS	4/4	2	86		○	:
GIMG	PopRk	1798	FA2_Brit Pop_XS	4/4	1	86		○	:
GIMG	PopRk	1799	FB2_Brit Pop_XS	4/4	1	86		○	:
GIMG	PopRk	1800	FC2_Brit Pop_XS	4/4	1	86		○	:
GIMG	PopRk	1801	BA2_Brit Pop_XS	4/4	1	86		○	:
GIMG	PopRk	1802	EA2_Brit Pop_XS	4/4	4	86		○	:
GIMG	PopRk	1803	EB2_Brit Pop_XS	4/4	4	86		○	:
GIMG	PopRk	1804	MA2_Brit Pop	4/4	2	86		○	:
GIMG	PopRk	1805	MB2_Brit Pop	4/4	2	86		○	:
GIMG	PopRk	1806	MC2_Brit Pop	4/4	2	86		○	:
GIMG	PopRk	1807	FA2_Brit Pop	4/4	1	86		○	:
GIMG	PopRk	1808	FB2_Brit Pop	4/4	1	86		○	:
GIMG	PopRk	1809	FC2_Brit Pop	4/4	1	86		○	:
GIMG	PopRk	1810	BA2_Brit Pop	4/4	1	86		○	:
GIMG	PopRk	1811	MA_BritPopSwing_XS	4/4	2	110		○	"Mega Steel"
GIMG	PopRk								

Arpeggio Type List

Main Category	Sub Category	ARP No.	ARP Name	Time Signature	Length	Original Tempo	Accent	Random SFX	Voice Type
GIMG	PopRk	1821	MB_BritPopSwing	4/4	2	110		○	"Mega Steel"
GIMG	PopRk	1822	MC_BritPopSwing	4/4	2	110		○	:
GIMG	PopRk	1823	FA_BritPopSwing	4/4	1	110		○	:
GIMG	PopRk	1824	FB_BritPopSwing	4/4	1	110		○	:
GIMG	PopRk	1825	FC_BritPopSwing	4/4	1	110		○	:
GIMG	PopRk	1826	BA_BritPopSwing	4/4	1	110		○	:
GIMG	PopRk	1827	MA_Cool8Beat_XS	4/4	2	100		○	"Mega 60s ChorusCombo"
GIMG	PopRk	1828	MB_Cool8Beat_XS	4/4	2	100		○	:
GIMG	PopRk	1829	MC_Cool8Beat_XS	4/4	2	100		○	:
GIMG	PopRk	1830	FA_Cool8Beat_XS	4/4	1	100		○	:
GIMG	PopRk	1831	FB_Cool8Beat_XS	4/4	1	100		○	:
GIMG	PopRk	1832	FC_Cool8Beat_XS	4/4	1	100		○	:
GIMG	PopRk	1833	BA_Cool8Beat_XS	4/4	1	100		○	:
GIMG	PopRk	1834	EA_Cool8Beat_XS	4/4	4	100		○	:
GIMG	PopRk	1835	EB_Cool8Beat_XS	4/4	4	100		○	:
GIMG	PopRk	1836	MA1_BritRockPop_XS	4/4	4	123		○	"Mega 1coil Old R&R"
GIMG	PopRk	1837	MB1_BritRockPop_XS	4/4	4	123		○	:
GIMG	PopRk	1838	MC1_BritRockPop_XS	4/4	4	123		○	:
GIMG	PopRk	1839	FA1_BritRockPop_XS	4/4	1	123		○	:
GIMG	PopRk	1840	FB1_BritRockPop_XS	4/4	1	123		○	:
GIMG	PopRk	1841	FC1_BritRockPop_XS	4/4	1	123		○	:
GIMG	PopRk	1842	BA1_BritRockPop_XS	4/4	1	123		○	:
GIMG	PopRk	1843	EA1_BritRockPop_XS	4/4	6	123		○	:
GIMG	PopRk	1844	MA2_BritRockPop_XS	4/4	4	123		○	"Mega 60s Clean"
GIMG	PopRk	1845	MB2_BritRockPop_XS	4/4	4	123		○	:
GIMG	PopRk	1846	MC2_BritRockPop_XS	4/4	4	123		○	:
GIMG	PopRk	1847	FA2_BritRockPop_XS	4/4	1	123		○	:
GIMG	PopRk	1848	FB2_BritRockPop_XS	4/4	1	123		○	:
GIMG	PopRk	1849	FC2_BritRockPop_XS	4/4	1	123		○	:
GIMG	PopRk	1850	BA2_BritRockPop_XS	4/4	1	123		○	:
GIMG	PopRk	1851	EA2_BritRockPop_XS	4/4	6	123		○	:
GIMG	PopRk	1852	MA1_80'sPopRock_XS	4/4	4	111		○	"Mega 1coil Old R&R"
GIMG	PopRk	1853	MB1_80'sPopRock_XS	4/4	4	111		○	:
GIMG	PopRk	1854	MC1_80'sPopRock_XS	4/4	4	111		○	:
GIMG	PopRk	1855	FA1_80'sPopRock_XS	4/4	1	111		○	:
GIMG	PopRk	1856	FB1_80'sPopRock_XS	4/4	1	111		○	:
GIMG	PopRk	1857	FC1_80'sPopRock_XS	4/4	1	111		○	:
GIMG	PopRk	1858	BA1_80'sPopRock_XS	4/4	1	111		○	:
GIMG	PopRk	1859	EA1_80'sPopRock_XS	4/4	7	111		○	:
GIMG	PopRk	1860	MA2_80'sPopRock_XS	4/4	4	111		○	"Mega 60s Clean"
GIMG	PopRk	1861	MB2_80'sPopRock_XS	4/4	4	111		○	:
GIMG	PopRk	1862	MC2_80'sPopRock_XS	4/4	4	111		○	:
GIMG	PopRk	1863	FA2_80'sPopRock_XS	4/4	1	111		○	:
GIMG	PopRk	1864	FB2_80'sPopRock_XS	4/4	1	111		○	:
GIMG	PopRk	1865	FC2_80'sPopRock_XS	4/4	1	111		○	:
GIMG	PopRk	1866	BA2_80'sPopRock_XS	4/4	1	111		○	:
GIMG	PopRk	1867	EA2_80'sPopRock_XS	4/4	7	111		○	:
GIMG	PopRk	1868	MA_80'sSynthRock_XS	4/4	4	96		○	"Mega 1coil Old R&R"
GIMG	PopRk	1869	MB_80'sSynthRock_XS	4/4	4	96		○	:
GIMG	PopRk	1870	MC_80'sSynthRock_XS	4/4	8	96		○	:
GIMG	PopRk	1871	FA_80'sSynthRock_XS	4/4	1	96		○	:
GIMG	PopRk	1872	FB_80'sSynthRock_XS	4/4	1	96		○	:
GIMG	PopRk	1873	FC_80'sSynthRock_XS	4/4	1	96		○	:
GIMG	PopRk	1874	BA_80'sSynthRock_XS	4/4	1	96		○	:
GIMG	PopRk	1875	EA_80'sSynthRock_XS	4/4	3	96		○	:
GIMG	PopRk	1876	MA_60sVintagePop_XS	4/4	4	132		○	:
GIMG	PopRk	1877	MB_60sVintagePop_XS	4/4	4	132		○	:
GIMG	PopRk	1878	MC_60sVintagePop_XS	4/4	4	132		○	:
GIMG	PopRk	1879	FA_60sVintagePop_XS	4/4	1	132		○	:
GIMG	PopRk	1880	FB_60sVintagePop_XS	4/4	1	132		○	:
GIMG	PopRk	1881	FC_60sVintagePop_XS	4/4	1	132		○	:
GIMG	PopRk	1882	BA_60sVintagePop_XS	4/4	1	132		○	:
GIMG	PopRk	1883	EA_60sVintagePop_XS	4/4	2	132		○	:
GIMG	PopRk	1884	MA_60sChartSwing_XS	4/4	4	123		○	"Mega 12 Steel"
GIMG	PopRk	1885	MB_60sChartSwing_XS	4/4	4	123		○	:
GIMG	PopRk	1886	MC_60sChartSwing_XS	4/4	4	123		○	:
GIMG	PopRk	1887	FA_60sChartSwing_XS	4/4	1	123		○	:
GIMG	PopRk	1888	FB_60sChartSwing_XS	4/4	1	123		○	:
GIMG	PopRk	1889	FC_60sChartSwing_XS	4/4	1	123		○	:
GIMG	PopRk	1890	BA_60sChartSwing_XS	4/4	1	123		○	:
GIMG	PopRk	1891	EA_60sChartSwing_XS	4/4	4	123		○	:
GIMG	Balad	1892	MA1_GuitarBallad_XS	4/4	8	94		○	"Mega Steel"
GIMG	Balad	1893	MB1_GuitarBallad_XS	4/4	8	94		○	:
GIMG	Balad	1894	MC1_GuitarBallad_XS	4/4	8	94		○	:
GIMG	Balad	1895	FA1_GuitarBallad_XS	4/4	1	94		○	:
GIMG	Balad	1896	FB1_GuitarBallad_XS	4/4	1	94		○	:
GIMG	Balad	1897	FC1_GuitarBallad_XS	4/4	1	94		○	:
GIMG	Balad	1898	BA1_GuitarBallad_XS	4/4	1	94		○	:
GIMG	Balad	1899	EA1_GuitarBallad_XS	4/4	4	94		○	:
GIMG	Balad	1900	EB1_GuitarBallad_XS	4/4	4	94		○	:
GIMG	Balad	1901	MA1_GuitarBallad	4/4	8	94		○	:
GIMG	Balad	1902	MB1_GuitarBallad	4/4	8	94		○	:
GIMG	Balad	1903	MC1_GuitarBallad	4/4	8	94		○	:

Main Category	Sub Category	ARP No.	ARP Name	Time Signature	Length	Original Tempo	Accent	Random SFX	Voice Type
GIMG	Balad	1904	FA1_GuitarBallad	4/4	1	94		○	"Mega Steel"
GIMG	Balad	1905	FB1_GuitarBallad	4/4	1	94		○	:
GIMG	Balad	1906	FC1_GuitarBallad	4/4	1	94		○	:
GIMG	Balad	1907	BA1_GuitarBallad	4/4	1	94		○	:
GIMG	Balad	1908	MA2_GuitarBallad_XS	4/4	8	94		○	"Mega Nylon"
GIMG	Balad	1909	MB2_GuitarBallad_XS	4/4	8	94		○	:
GIMG	Balad	1910	MC2_GuitarBallad_XS	4/4	8	94		○	:
GIMG	Balad	1911	FA2_GuitarBallad_XS	4/4	1	94		○	:
GIMG	Balad	1912	FB2_GuitarBallad_XS	4/4	1	94		○	:
GIMG	Balad	1913	FC2_GuitarBallad_XS	4/4	1	94		○	:
GIMG	Balad	1914	BA2_GuitarBallad_XS	4/4	1	94		○	:
GIMG	Balad	1915	EA2_GuitarBallad_XS	4/4	4	94		○	:
GIMG	Balad	1916	EB2_GuitarBallad_XS	4/4	4	94		○	:
GIMG	Balad	1917	MA2_GuitarBallad	4/4	8	94		○	:
GIMG	Balad	1918	MB2_GuitarBallad	4/4	8	94		○	:
GIMG	Balad	1919	MC2_GuitarBallad	4/4	8	94		○	:
GIMG	Balad	1920	FA2_GuitarBallad	4/4	1	94		○	:
GIMG	Balad	1921	FB2_GuitarBallad	4/4	1	94		○	:
GIMG	Balad	1922	FC2_GuitarBallad	4/4	1	94		○	:
GIMG	Balad	1923	BA2_GuitarBallad	4/4	1	94		○	:
GIMG	Balad	1924	MA_Unplugged 1_XS	4/4	4	120		○	"Mega Steel"
GIMG	Balad	1925	MB_Unplugged 1_XS	4/4	4	120		○	:
GIMG	Balad	1926	MC_Unplugged 1_XS	4/4	4	120		○	:
GIMG	Balad	1927	FA_Unplugged 1_XS	4/4	1	120		○	:
GIMG	Balad	1928	FB_Unplugged 1_XS	4/4	1	120		○	:
GIMG	Balad	1929	FC_Unplugged 1_XS	4/4	1	120		○	:
GIMG	Balad	1930	BA_Unplugged 1_XS	4/4	1	120		○	:
GIMG	Balad	1931	MA_Unplugged 1	4/4	4	120		○	:
GIMG	Balad	1932	MB_Unplugged 1	4/4	4	120		○	:
GIMG	Balad	1933	MC_Unplugged 1	4/4	4	120		○	:
GIMG	Balad	1934	FA_Unplugged 1	4/4	1	120		○	:
GIMG	Balad	1935	FB_Unplugged 1	4/4	1	120		○	:
GIMG	Balad	1936	FC_Unplugged 1	4/4	1	120		○	:
GIMG	Balad	1937	BA_Unplugged 1	4/4	1	120		○	:
GIMG	Balad	1938	MA_Unplugged 2_XS	4/4	8	120		○	:
GIMG	Balad	1939	MB_Unplugged 2_XS	4/4	8	120		○	:
GIMG	Balad	1940	MC_Unplugged 2_XS	4/4	8	120		○	:
GIMG	Balad	1941	FA_Unplugged 2_XS	4/4	1	120		○	:
GIMG	Balad	1942	FB_Unplugged 2_XS	4/4	1	120		○	:
GIMG	Balad	1943	FC_Unplugged 2_XS	4/4	1	120		○	:
GIMG	Balad	1944	BA_Unplugged 2_XS	4/4	1	120		○	:
GIMG	Balad	1945	EA_Unplugged 2_XS	4/4	5	120		○	:
GIMG	Balad	1946	EB_Unplugged 2_XS	4/4	4	120		○	:
GIMG	Balad	1947	MA_Unplugged 2	4/4	8	120		○	:
GIMG	Balad	1948	MB_Unplugged 2	4/4	8	120		○	:
GIMG	Balad	1949	MC_Unplugged 2	4/4	8	120		○	:
GIMG	Balad	1950	FA_Unplugged 2	4/4	1	120		○	:
GIMG	Balad	1951	FB_Unplugged 2	4/4	1	120		○	:
GIMG	Balad	1952	FC_Unplugged 2	4/4	1	120		○	:
GIMG	Balad	1953	BA_Unplugged 2	4/4	1	120		○	:
GIMG	Balad	1954	MA_EP Ballad_XS	4/4	2	60		○	"Mega 1coil SlapClean"
GIMG	Balad	1955	MB_EP Ballad_XS	4/4	2	60		○	:
GIMG	Balad	1956	MC_EP Ballad_XS	4/4	2	60		○	:
GIMG	Balad	1957	FA_EP Ballad_XS	4/4	1	60		○	:
GIMG	Balad	1958	FB_EP Ballad_XS	4/4	1	60		○	:
GIMG	Balad	1959	FC_EP Ballad_XS	4/4	1	60		○	:
GIMG	Balad	1960	BA_EP Ballad_XS	4/4	1	60		○	:
GIMG	Balad	1961	EA_EP Ballad_XS	4/4	4	60		○	:
GIMG	Balad	1962	EB_EP Ballad_XS	4/4	4	60		○	:
GIMG	HipHp	1963	MA_Dancehall_XS	4/4	4	103		○	"Mega 1coil Old R&R"
GIMG	HipHp	1964	MB_Dancehall_XS	4/4	4	103		○	:
GIMG	HipHp	1965	MC_Dancehall_XS	4/4	4	103		○	:
GIMG	HipHp	1966	FA_Dancehall_XS	4/4	1	103		○	:
GIMG	HipHp	1967	FB_Dancehall_XS	4/4	1	103		○	:
GIMG	HipHp	1968	FC_Dancehall_XS	4/4	1	103		○	:
GIMG	HipHp	1969	BA_Dancehall_XS	4/4	1	103		○	:
GIMG	HipHp	1970	EA_Dancehall_XS	4/4	3	103		○	:
GIMG	R&B-M	1971	MA_Slow & Easy_XS	4/4	4	72		○	"Mega 60s Clean"
GIMG	R&B-M	1972	MB_Slow & Easy_XS	4/4	4	72		○	:
GIMG	R&B-M	1973	MC_Slow & Easy_XS	4/4	4	72		○	:
GIMG	R&B-M	1974	FA_Slow & Easy_XS	4/4	1	72		○	:
GIMG	R&B-M	1975	FB_Slow & Easy_XS	4/4	1	72		○	:
GIMG	R&B-M	1976	FC_Slow & Easy_XS	4/4	1	72		○	:
GIMG	R&B-M	1977	BA_Slow & Easy_XS	4/4	1	72		○	:
GIMG	R&B-M	1978	EA_S						

Arpeggio Type List

Main Category	Sub Category	ARP No.	ARP Name	Time Signature	Length	Original Tempo	Accent	Random SFX	Voice Type
GMG	R&B-M	1987	EA_R&B_XS	4/4	4	83		○	"Mega 60s Tube Tone"
GMG	R&B-M	1988	EB_R&B_XS	4/4	4	83		○	:
GMG	R&B-M	1989	MA_New R&B 1_XS	4/4	2	98		○	"Mega Steel"
GMG	R&B-M	1990	MB_New R&B 1_XS	4/4	2	98		○	:
GMG	R&B-M	1991	MC_New R&B 1_XS	4/4	2	98		○	:
GMG	R&B-M	1992	FA_New R&B 1_XS	4/4	1	98		○	:
GMG	R&B-M	1993	FB_New R&B 1_XS	4/4	1	98		○	:
GMG	R&B-M	1994	FC_New R&B 1_XS	4/4	1	98		○	:
GMG	R&B-M	1995	BA_New R&B 1_XS	4/4	1	98		○	:
GMG	R&B-M	1996	EA_New R&B 1_XS	4/4	3	98		○	:
GMG	R&B-M	1997	EB_New R&B 1_XS	4/4	4	98		○	:
GMG	R&B-M	1998	MA_R&B Ballad 1_XS	4/4	4	70		○	"Mega 60s Slap Clean"
GMG	R&B-M	1999	MB_R&B Ballad 1_XS	4/4	4	70		○	:
GMG	R&B-M	2000	MC_R&B Ballad 1_XS	4/4	4	70		○	:
GMG	R&B-M	2001	FA_R&B Ballad 1_XS	4/4	1	70		○	:
GMG	R&B-M	2002	FB_R&B Ballad 1_XS	4/4	1	70		○	:
GMG	R&B-M	2003	FC_R&B Ballad 1_XS	4/4	1	70		○	:
GMG	R&B-M	2004	BA_R&B Ballad 1_XS	4/4	1	70		○	:
GMG	R&B-C	2005	MA_StandrdDisco_XS	4/4	4	120		○	"Mega 60s Clean"
GMG	R&B-C	2006	MB_StandrdDisco_XS	4/4	4	120		○	:
GMG	R&B-C	2007	MC_StandrdDisco_XS	4/4	4	120		○	:
GMG	R&B-C	2008	FA_StandrdDisco_XS	4/4	1	120		○	:
GMG	R&B-C	2009	FB_StandrdDisco_XS	4/4	1	120		○	:
GMG	R&B-C	2010	FC_StandrdDisco_XS	4/4	1	120		○	:
GMG	R&B-C	2011	BA_StandrdDisco_XS	4/4	1	120		○	:
GMG	R&B-C	2012	EA_StandrdDisco_XS	4/4	3	120		○	:
GMG	R&B-C	2013	EB_StandrdDisco_XS	4/4	3	120		○	:
GMG	R&B-C	2014	MA_Retro Disco_XS	4/4	4	108		○	"Mega 1coilSlpPedalWah"
GMG	R&B-C	2015	MB_Retro Disco_XS	4/4	4	108		○	:
GMG	R&B-C	2016	MC_Retro Disco_XS	4/4	4	108		○	:
GMG	R&B-C	2017	FA_Retro Disco_XS	4/4	1	108		○	:
GMG	R&B-C	2018	FB_Retro Disco_XS	4/4	1	108		○	:
GMG	R&B-C	2019	FC_Retro Disco_XS	4/4	1	108		○	:
GMG	R&B-C	2020	BA_Retro Disco_XS	4/4	1	108		○	:
GMG	R&B-C	2021	EA_Retro Disco_XS	4/4	4	108		○	:
GMG	R&B-C	2022	EB_Retro Disco_XS	4/4	4	108		○	:
GMG	R&B-C	2023	MA_70sCoolDisco_XS	4/4	4	114		○	"Mega 60s ChorusCombo"
GMG	R&B-C	2024	MB_70sCoolDisco_XS	4/4	4	114		○	:
GMG	R&B-C	2025	MC_70sCoolDisco_XS	4/4	4	114		○	:
GMG	R&B-C	2026	FA_70sCoolDisco_XS	4/4	1	114		○	:
GMG	R&B-C	2027	FB_70sCoolDisco_XS	4/4	1	114		○	:
GMG	R&B-C	2028	FC_70sCoolDisco_XS	4/4	1	114		○	:
GMG	R&B-C	2029	BA_70sCoolDisco_XS	4/4	1	114		○	:
GMG	R&B-C	2030	EA_70sCoolDisco_XS	4/4	4	114		○	:
GMG	R&B-C	2031	EB_70sCoolDisco_XS	4/4	3	114		○	:
GMG	R&B-C	2032	MA_Philadelphia_XS	4/4	2	100		○	"Mega 60s Pedal Wah"
GMG	R&B-C	2033	MB_Philadelphia_XS	4/4	2	100		○	:
GMG	R&B-C	2034	MC_Philadelphia_XS	4/4	2	100		○	:
GMG	R&B-C	2035	FA_Philadelphia_XS	4/4	1	100		○	:
GMG	R&B-C	2036	FB_Philadelphia_XS	4/4	1	100		○	:
GMG	R&B-C	2037	FC_Philadelphia_XS	4/4	1	100		○	:
GMG	R&B-C	2038	BA_Philadelphia_XS	4/4	1	100		○	:
GMG	R&B-C	2039	MA_Philadelphia	4/4	2	100		○	:
GMG	R&B-C	2040	MB_Philadelphia	4/4	2	100		○	:
GMG	R&B-C	2041	MC_Philadelphia	4/4	2	100		○	:
GMG	R&B-C	2042	FA_Philadelphia	4/4	1	100		○	:
GMG	R&B-C	2043	FB_Philadelphia	4/4	1	100		○	:
GMG	R&B-C	2044	FC_Philadelphia	4/4	1	100		○	:
GMG	R&B-C	2045	BA_Philadelphia	4/4	1	100		○	:
GMG	R&B-C	2046	EA_Philadelphia_XS	4/4	4	100		○	:
GMG	R&B-C	2047	EB_Philadelphia_XS	4/4	3	100		○	:
GMG	R&B-C	2048	MA_Soul 1_XS	4/4	2	116		○	"Mega 1coil Slap Dist"
GMG	R&B-C	2049	MB_Soul 1_XS	4/4	2	116		○	:
GMG	R&B-C	2050	MC_Soul 1_XS	4/4	2	116		○	:
GMG	R&B-C	2051	FA_Soul 1_XS	4/4	1	116		○	:
GMG	R&B-C	2052	FB_Soul 1_XS	4/4	1	116		○	:
GMG	R&B-C	2053	FC_Soul 1_XS	4/4	1	116		○	:
GMG	R&B-C	2054	BA_Soul 1_XS	4/4	1	116		○	:
GMG	R&B-C	2055	EA_Soul 1_XS	4/4	4	116		○	:
GMG	R&B-C	2056	EB_Soul 1_XS	4/4	3	116		○	:
GMG	R&B-C	2057	MA_70sChartSoul_XS	4/4	2	108		○	"Mega 60s ChorusCombo"
GMG	R&B-C	2058	MB_70sChartSoul_XS	4/4	2	108		○	:
GMG	R&B-C	2059	MC_70sChartSoul_XS	4/4	2	108		○	:
GMG	R&B-C	2060	FA_70sChartSoul_XS	4/4	1	108		○	:
GMG	R&B-C	2061	FB_70sChartSoul_XS	4/4	1	108		○	:
GMG	R&B-C	2062	FC_70sChartSoul_XS	4/4	1	108		○	:
GMG	R&B-C	2063	BA_70sChartSoul_XS	4/4	1	108		○	:
GMG	R&B-C	2064	EA_70sChartSoul_XS	4/4	5	108		○	:
GMG	R&B-C	2065	EB_70sChartSoul_XS	4/4	3	108		○	:
GMG	R&B-C	2066	MA_Frankly Soul_XS	4/4	4	120		○	"Mega 60s Clean"
GMG	R&B-C	2067	MB_Frankly Soul_XS	4/4	4	120		○	:
GMG	R&B-C	2068	MC_Frankly Soul_XS	4/4	4	120		○	:
GMG	R&B-C	2069	FA_Frankly Soul_XS	4/4	1	120		○	:

Main Category	Sub Category	ARP No.	ARP Name	Time Signature	Length	Original Tempo	Accent	Random SFX	Voice Type
GMG	R&B-C	2070	FB_Frankly Soul_XS	4/4	1	120		○	"Mega 60s Clean"
GMG	R&B-C	2071	FC_Frankly Soul_XS	4/4	1	120		○	:
GMG	R&B-C	2072	BA_Frankly Soul_XS	4/4	1	120		○	:
GMG	R&B-C	2073	MA_Frankly Soul	4/4	4	120		○	:
GMG	R&B-C	2074	MB_Frankly Soul	4/4	4	120		○	:
GMG	R&B-C	2075	MC_Frankly Soul	4/4	4	120		○	:
GMG	R&B-C	2076	FA_Frankly Soul	4/4	1	120		○	:
GMG	R&B-C	2077	FB_Frankly Soul	4/4	1	120		○	:
GMG	R&B-C	2078	FC_Frankly Soul	4/4	1	120		○	:
GMG	R&B-C	2079	BA_Frankly Soul	4/4	1	120		○	:
GMG	R&B-C	2080	EA_Frankly Soul_XS	4/4	3	120		○	:
GMG	R&B-C	2081	EB_Frankly Soul_XS	4/4	4	120		○	:
GMG	R&B-C	2082	MA_Soul Beat_XS	4/4	4	124		○	:
GMG	R&B-C	2083	MB_Soul Beat_XS	4/4	4	124		○	:
GMG	R&B-C	2084	MC_Soul Beat_XS	4/4	4	124		○	:
GMG	R&B-C	2085	FA_Soul Beat_XS	4/4	1	124		○	:
GMG	R&B-C	2086	FB_Soul Beat_XS	4/4	1	124		○	:
GMG	R&B-C	2087	FC_Soul Beat_XS	4/4	1	124		○	:
GMG	R&B-C	2088	BA_Soul Beat_XS	4/4	1	124		○	:
GMG	R&B-C	2089	EA_Soul Beat_XS	4/4	3	123		○	:
GMG	R&B-C	2090	EB_Soul Beat_XS	4/4	3	123		○	:
GMG	R&B-C	2091	MA1_Soul Band_XS	4/4	4	129		○	"Mega Steel"
GMG	R&B-C	2092	MB1_Soul Band_XS	4/4	4	129		○	:
GMG	R&B-C	2093	MC1_Soul Band_XS	4/4	4	129		○	:
GMG	R&B-C	2094	FA1_Soul Band_XS	4/4	1	129		○	:
GMG	R&B-C	2095	FB1_Soul Band_XS	4/4	1	129		○	:
GMG	R&B-C	2096	FC1_Soul Band_XS	4/4	1	129		○	:
GMG	R&B-C	2097	BA1_Soul Band_XS	4/4	1	129		○	:
GMG	R&B-C	2098	MA2_Soul Band_XS	4/4	4	129		○	"Mega 60s Tube Tone"
GMG	R&B-C	2099	MB2_Soul Band_XS	4/4	4	129		○	:
GMG	R&B-C	2100	MC2_Soul Band_XS	4/4	4	129		○	:
GMG	R&B-C	2101	FA2_Soul Band_XS	4/4	1	129		○	:
GMG	R&B-C	2102	FB2_Soul Band_XS	4/4	1	129		○	:
GMG	R&B-C	2103	FC2_Soul Band_XS	4/4	1	129		○	:
GMG	R&B-C	2104	BA2_Soul Band_XS	4/4	1	129		○	:
GMG	R&B-C	2105	MA_Soul Shuffle_XS	4/4	4	98		○	"Mega 60s Clean"
GMG	R&B-C	2106	MB_Soul Shuffle_XS	4/4	4	98		○	:
GMG	R&B-C	2107	MC_Soul Shuffle_XS	4/4	4	98		○	:
GMG	R&B-C	2108	FA_Soul Shuffle_XS	4/4	1	98		○	:
GMG	R&B-C	2109	FB_Soul Shuffle_XS	4/4	1	98		○	:
GMG	R&B-C	2110	FC_Soul Shuffle_XS	4/4	1	98		○	:
GMG	R&B-C	2111	BA_Soul Shuffle_XS	4/4	1	98		○	:
GMG	R&B-C	2112	EA_Soul Shuffle_XS	4/4	3	98		○	:
GMG	R&B-C	2113	EB_Soul Shuffle_XS	4/4	3	98		○	:
GMG	R&B-C	2114	MA_Soul Swing_XS	4/4	4	124		○	:
GMG	R&B-C	2115	MB_Soul Swing_XS	4/4	4	124		○	:
GMG	R&B-C	2116	MC_Soul Swing_XS	4/4	4	124		○	:
GMG	R&B-C	2117	FA_Soul Swing_XS	4/4	1	124		○	:
GMG	R&B-C	2118	FB_Soul Swing_XS	4/4	1	124		○	:
GMG	R&B-C	2119	FC_Soul Swing_XS	4/4	1	124		○	:
GMG	R&B-C	2120	BA_Soul Swing_XS	4/4	1	124		○	:
GMG	R&B-C	2121	EA_Soul Swing_XS	4/4	3	123		○	:
GMG	R&B-C	2122	EB_Soul Swing_XS	4/4	5	123		○	:
GMG	R&B-C	2123	MA_GospelBrothr_XS	4/4	4	108		○	"Mega 60s ChorusCombo"
GMG	R&B-C	2124	MB_GospelBrothr_XS	4/4	4	108		○	:
GMG	R&B-C	2125	MC_GospelBrothr_XS	4/4	4	108		○	:
GMG	R&B-C	2126	FA_GospelBrothr_XS	4/4	1	108		○	:
GMG	R&B-C	2127	FB_GospelBrothr_XS	4/4	1	108		○	:
GMG	R&B-C	2128	FC_GospelBrothr_XS	4/4	1	108		○	:
GMG	R&B-C	2129	BA_GospelBrothr_XS	4/4	1	108		○	:
GMG	R&B-C	2130	EA_GospelBrothr_XS	4/4	4	108		○	:
GMG	R&B-C	2131	EB_GospelBrothr_XS	4/4	3	108		○	:
GMG	Funk	2132	MA_Funk 1_XS	4/4	8	104		○	"Mega 1coil SlapClean"
GMG	Funk	2133	MB_Funk 1_XS	4/4	8	104		○	:
GMG	Funk	2134	MC_Funk 1_XS	4/4	8	104		○	:
GMG	Funk	2135	FA_Funk 1_XS	4/4	1	104		○	:
GMG	Funk	2136	FB_Funk 1_XS	4/4	1	104		○	:
GMG	Funk	2137	FC_Funk 1_XS	4/4	1	104		○	:
GMG	Funk	2138	BA_Funk 1_XS	4/4	1	104		○	:
GMG	Funk	2139	EA_Funk 1_XS	4/4	9	104		○	:
GMG	Funk								

Arpeggio Type List

Main Category	Sub Category	ARP No.	ARP Name	Time Signature	Length	Original Tempo	Accent	Random SFX	Voice Type
GIMG	Funk	2153	FA1_Funk PopRock	4/4	1	94		○	"Mega 60s Clean"
GIMG	Funk	2154	FB1_Funk PopRock	4/4	1	94		○	:
GIMG	Funk	2155	FC1_Funk PopRock	4/4	1	94		○	:
GIMG	Funk	2156	BA1_Funk PopRock	4/4	1	94		○	:
GIMG	Funk	2157	MA2_Funk PopRock_XS	4/4	4	95		○	"Mega 1coil Slap Dist"
GIMG	Funk	2158	MB2_Funk PopRock_XS	4/4	4	95		○	:
GIMG	Funk	2159	MC2_Funk PopRock_XS	4/4	4	95		○	:
GIMG	Funk	2160	FA2_Funk PopRock_XS	4/4	1	95		○	:
GIMG	Funk	2161	FB2_Funk PopRock_XS	4/4	1	95		○	:
GIMG	Funk	2162	FC2_Funk PopRock_XS	4/4	1	95		○	:
GIMG	Funk	2163	BA2_Funk PopRock_XS	4/4	1	95		○	:
GIMG	Funk	2164	MA2_Funk PopRock	4/4	4	94		○	:
GIMG	Funk	2165	MB2_Funk PopRock	4/4	4	94		○	:
GIMG	Funk	2166	MC2_Funk PopRock	4/4	4	94		○	:
GIMG	Funk	2167	FA2_Funk PopRock	4/4	1	94		○	:
GIMG	Funk	2168	FB2_Funk PopRock	4/4	1	94		○	:
GIMG	Funk	2169	FC2_Funk PopRock	4/4	1	94		○	:
GIMG	Funk	2170	BA2_Funk PopRock	4/4	1	94		○	:
GIMG	Funk	2171	MA_Jazz Funk 1_XS	4/4	4	120		○	"Mega 60s Clean"
GIMG	Funk	2172	MB_Jazz Funk 1_XS	4/4	4	120		○	:
GIMG	Funk	2173	MC_Jazz Funk 1_XS	4/4	4	120		○	:
GIMG	Funk	2174	FA_Jazz Funk 1_XS	4/4	1	120		○	:
GIMG	Funk	2175	FB_Jazz Funk 1_XS	4/4	1	120		○	:
GIMG	Funk	2176	FC_Jazz Funk 1_XS	4/4	1	120		○	:
GIMG	Funk	2177	BA_Jazz Funk 1_XS	4/4	1	120		○	:
GIMG	Funk	2178	EA_Jazz Funk 1_XS	4/4	3	120		○	:
GIMG	Funk	2179	EB_Jazz Funk 1_XS	4/4	3	120		○	:
GIMG	Funk	2180	MA_Jazz Funk 1	4/4	4	120		○	:
GIMG	Funk	2181	MB_Jazz Funk 1	4/4	4	120		○	:
GIMG	Funk	2182	MC_Jazz Funk 1	4/4	4	120		○	:
GIMG	Funk	2183	FA_Jazz Funk 1	4/4	1	120		○	:
GIMG	Funk	2184	FB_Jazz Funk 1	4/4	1	120		○	:
GIMG	Funk	2185	FC_Jazz Funk 1	4/4	1	120		○	:
GIMG	Funk	2186	BA_Jazz Funk 1	4/4	1	120		○	:
GIMG	Funk	2187	MA_Jazz Pop_XS	4/4	2	102		○	"Mega 60s ChorusCombo"
GIMG	Funk	2188	MB_Jazz Pop_XS	4/4	2	102		○	:
GIMG	Funk	2189	MC_Jazz Pop_XS	4/4	2	102		○	:
GIMG	Funk	2190	FA_Jazz Pop_XS	4/4	1	102		○	:
GIMG	Funk	2191	FB_Jazz Pop_XS	4/4	1	102		○	:
GIMG	Funk	2192	FC_Jazz Pop_XS	4/4	1	102		○	:
GIMG	Funk	2193	BA_Jazz Pop_XS	4/4	1	102		○	:
GIMG	Funk	2194	MA_Jazz Pop	4/4	2	102		○	:
GIMG	Funk	2195	MB_Jazz Pop	4/4	2	102		○	:
GIMG	Funk	2196	MC_Jazz Pop	4/4	2	102		○	:
GIMG	Funk	2197	FA_Jazz Pop	4/4	1	102		○	:
GIMG	Funk	2198	FB_Jazz Pop	4/4	1	102		○	:
GIMG	Funk	2199	FC_Jazz Pop	4/4	1	102		○	:
GIMG	Funk	2200	BA_Jazz Pop	4/4	1	102		○	:
GIMG	Funk	2201	MA_Gospel Funk_XS	4/4	4	106		○	"Mega 60s Clean"
GIMG	Funk	2202	MB_Gospel Funk_XS	4/4	4	106		○	:
GIMG	Funk	2203	MC_Gospel Funk_XS	4/4	4	106		○	:
GIMG	Funk	2204	FA_Gospel Funk_XS	4/4	1	106		○	:
GIMG	Funk	2205	FB_Gospel Funk_XS	4/4	1	106		○	:
GIMG	Funk	2206	FC_Gospel Funk_XS	4/4	1	106		○	:
GIMG	Funk	2207	BA_Gospel Funk_XS	4/4	1	106		○	:
GIMG	Funk	2208	EA_Gospel Funk_XS	4/4	4	106		○	:
GIMG	Funk	2209	EB_Gospel Funk_XS	4/4	3	106		○	:
GIMG	Funk	2210	MA_Funk Disco_XS	4/4	2	126		○	"Mega 60s Small Blues"
GIMG	Funk	2211	MB_Funk Disco_XS	4/4	2	126		○	:
GIMG	Funk	2212	MC_Funk Disco_XS	4/4	2	126		○	:
GIMG	Funk	2213	FA_Funk Disco_XS	4/4	1	126		○	:
GIMG	Funk	2214	FB_Funk Disco_XS	4/4	1	126		○	:
GIMG	Funk	2215	FC_Funk Disco_XS	4/4	1	126		○	:
GIMG	Funk	2216	BA_Funk Disco_XS	4/4	1	126		○	:
GIMG	Funk	2217	EA_Funk Disco_XS	4/4	4	126		○	:
GIMG	Funk	2218	EB_Funk Disco_XS	4/4	3	126		○	:
GIMG	Funk	2219	MA_70sDiscoFunk_XS	4/4	4	112		○	"Mega 1coil Slap Dist"
GIMG	Funk	2220	MB_70sDiscoFunk_XS	4/4	4	112		○	:
GIMG	Funk	2221	MC_70sDiscoFunk_XS	4/4	4	112		○	:
GIMG	Funk	2222	FA_70sDiscoFunk_XS	4/4	1	112		○	:
GIMG	Funk	2223	FB_70sDiscoFunk_XS	4/4	1	112		○	:
GIMG	Funk	2224	FC_70sDiscoFunk_XS	4/4	1	112		○	:
GIMG	Funk	2225	BA_70sDiscoFunk_XS	4/4	1	112		○	:
GIMG	Funk	2226	EA_70sDiscoFunk_XS	4/4	4	112		○	:
GIMG	Funk	2227	EB_70sDiscoFunk_XS	4/4	3	112		○	:
GIMG	House	2228	MA_Disco House_XS	4/4	4	126		○	"Mega 60s ChorusCombo"
GIMG	House	2229	MB_Disco House_XS	4/4	4	126		○	:
GIMG	House	2230	MC_Disco House_XS	4/4	4	126		○	:
GIMG	House	2231	FA_Disco House_XS	4/4	1	126		○	:
GIMG	House	2232	FB_Disco House_XS	4/4	1	126		○	:
GIMG	House	2233	FC_Disco House_XS	4/4	1	126		○	:
GIMG	House	2234	BA_Disco House_XS	4/4	1	126		○	:
GIMG	Jazz	2235	MA_JazzGtrClub_XS	4/4	8	142		○	"Mega Jazz Guitar"

Main Category	Sub Category	ARP No.	ARP Name	Time Signature	Length	Original Tempo	Accent	Random SFX	Voice Type
GIMG	Jazz	2236	MB_JazzGtrClub_XS	4/4	8	142		○	"Mega Jazz Guitar"
GIMG	Jazz	2237	MC_JazzGtrClub_XS	4/4	8	142		○	:
GIMG	Jazz	2238	FA_JazzGtrClub_XS	4/4	1	142		○	:
GIMG	Jazz	2239	FB_JazzGtrClub_XS	4/4	1	142		○	:
GIMG	Jazz	2240	FC_JazzGtrClub_XS	4/4	1	142		○	:
GIMG	Jazz	2241	BA_JazzGtrClub_XS	4/4	1	142		○	:
GIMG	Jazz	2242	EA_JazzGtrClub_XS	4/4	6	142		○	:
GIMG	Jazz	2243	MA_JazzWaltzMed_XS	3/4	8	180		○	:
GIMG	Jazz	2244	MB_JazzWaltzMed_XS	3/4	8	180		○	:
GIMG	Jazz	2245	MC_JazzWaltzMed_XS	3/4	8	180		○	:
GIMG	Jazz	2246	FA_JazzWaltzMed_XS	3/4	1	180		○	:
GIMG	Jazz	2247	FB_JazzWaltzMed_XS	3/4	1	180		○	:
GIMG	Jazz	2248	FC_JazzWaltzMed_XS	3/4	1	180		○	:
GIMG	Jazz	2249	BA_JazzWaltzMed_XS	3/4	1	180		○	:
GIMG	Jazz	2250	EA_JazzWaltzMed_XS	3/4	7	180		○	:
GIMG	Jazz	2251	MA_ShuffleBlues_XS	4/4	4	115		○	"Mega 60s Tube Tone"
GIMG	Jazz	2252	MB_ShuffleBlues_XS	4/4	4	115		○	:
GIMG	Jazz	2253	MC_ShuffleBlues_XS	4/4	4	115		○	:
GIMG	Jazz	2254	FA_ShuffleBlues_XS	4/4	1	115		○	:
GIMG	Jazz	2255	FB_ShuffleBlues_XS	4/4	1	115		○	:
GIMG	Jazz	2256	FC_ShuffleBlues_XS	4/4	1	115		○	:
GIMG	Jazz	2257	BA_ShuffleBlues_XS	4/4	1	115		○	:
GIMG	Jazz	2258	EA_ShuffleBlues_XS	4/4	5	115		○	:
GIMG	Jazz	2259	EB_ShuffleBlues_XS	4/4	6	115		○	:
GIMG	Jazz	2260	MA_Slow Blues 1_XS	4/4	2	49		○	:
GIMG	Jazz	2261	MB_Slow Blues 1_XS	4/4	2	49		○	:
GIMG	Jazz	2262	MC_Slow Blues 1_XS	4/4	2	49		○	:
GIMG	Jazz	2263	FA_Slow Blues 1_XS	4/4	1	49		○	:
GIMG	Jazz	2264	FB_Slow Blues 1_XS	4/4	1	49		○	:
GIMG	Jazz	2265	FC_Slow Blues 1_XS	4/4	1	49		○	:
GIMG	Jazz	2266	BA_Slow Blues 1_XS	4/4	1	49		○	:
GIMG	Jazz	2267	EA_Slow Blues 1_XS	4/4	3	49		○	:
GIMG	Jazz	2268	EB_Slow Blues 1_XS	4/4	3	49		○	:
GIMG	Jazz	2269	MA_Piano Boogie_XS	4/4	8	160		○	"Mega 60s ChorusCombo"
GIMG	Jazz	2270	MB_Piano Boogie_XS	4/4	4	160		○	:
GIMG	Jazz	2271	MC_Piano Boogie_XS	4/4	4	160		○	:
GIMG	Jazz	2272	FA_Piano Boogie_XS	4/4	1	160		○	:
GIMG	Jazz	2273	FB_Piano Boogie_XS	4/4	1	160		○	:
GIMG	Jazz	2274	FC_Piano Boogie_XS	4/4	1	160		○	:
GIMG	Jazz	2275	BA_Piano Boogie_XS	4/4	1	160		○	:
GIMG	Jazz	2276	EA_Piano Boogie_XS	4/4	5	160		○	:
GIMG	Jazz	2277	EB_Piano Boogie_XS	4/4	5	160		○	:
GIMG	Latin	2278	MA_Brazil Samba_XS	4/4	4	96		○	"Mega Nylon"
GIMG	Latin	2279	MB_Brazil Samba_XS	4/4	4	96		○	:
GIMG	Latin	2280	MC_Brazil Samba_XS	4/4	4	96		○	:
GIMG	Latin	2281	FA_Brazil Samba_XS	4/4	1	96		○	:
GIMG	Latin	2282	FB_Brazil Samba_XS	4/4	1	96		○	:
GIMG	Latin	2283	FC_Brazil Samba_XS	4/4	1	96		○	:
GIMG	Latin	2284	BA_Brazil Samba_XS	4/4	1	96		○	:
GIMG	Latin	2285	EA_Brazil Samba_XS	4/4	4	96		○	:
GIMG	Latin	2286	EB_Brazil Samba_XS	4/4	4	96		○	:
GIMG	Latin	2287	MA_Bossa_XS	4/4	4	124		○	:
GIMG	Latin	2288	MB_Bossa_XS	4/4	4	124		○	:
GIMG	Latin	2289	MC_Bossa_XS	4/4	4	124		○	:
GIMG	Latin	2290	FA_Bossa_XS	4/4	1	124		○	:
GIMG	Latin	2291	FB_Bossa_XS	4/4	1	124		○	:
GIMG	Latin	2292	FC_Bossa_XS	4/4	1	124		○	:
GIMG	Latin	2293	BA_Bossa_XS	4/4	1	124		○	:
GIMG	Latin	2294	EA_Bossa_XS	4/4	4	123		○	:
GIMG	Latin	2295	EB_Bossa_XS	4/4	4	123		○	:
GIMG	Latin	2296	MA_Bossa	4/4	4	123		○	:
GIMG	Latin	2297	MB_Bossa	4/4	4	123		○	:
GIMG	Latin	2298	MC_Bossa	4/4	4	123		○	:
GIMG	Latin	2299	FA_Bossa	4/4	1	123		○	:
GIMG	Latin	2300	FB_Bossa	4/4	1	123		○	:
GIMG	Latin	2301	FC_Bossa	4/4	1	123		○	:
GIMG	Latin	2302	BA_Bossa	4/4	1	123		○	:
GIMG	Latin	2303	MA_Merengue_XS	4/4	4	130		○	"Mega Steel"
GIMG	Latin	2304	MB_Merengue_XS	4/4	4	130		○	:
GIMG	Latin	2305	MC_Merengue_XS	4/4	4	130		○	:
GIMG	Latin	2306	FA_Merengue_XS	4/4	1	130		○	:
GIMG	Latin	2307	FB_Merengue_XS	4/4	1	130		○	:
GIMG	Latin	2308	FC_Merengue_XS	4/4	1	130		○	:
GIMG	Latin	2309	BA_Merengue_XS	4/4	1	130		○	:
GIMG	Latin	2310	EA_Merengue_XS	4/4	3	130		○	:
GIMG	Latin	2311	EB_Merengue_XS	4/4	3	130		○	:
GIMG	Latin	2312	MA_Merengue	4/4	4	130		○	:
GIMG	Latin	2313	MB_Merengue	4/4	4	130		○	:
GIMG	Latin	2314	MC_Merengue	4/4	4	130		○	:
GIMG	Latin	2315	FA_Merengue	4/4	1	130			

Main Category	Sub Category	ARP No.	ARP Name	Time Signature	Length	Original Tempo	Accent	Random SFX	Voice Type
GIMG	World	2319	MA1_ReggaeShuffle_XS	4/4	4	90		○	"Mega 60s Clean"
GIMG	World	2320	MB1_ReggaeShuffle_XS	4/4	4	90		○	:
GIMG	World	2321	MC1_ReggaeShuffle_XS	4/4	4	90		○	:
GIMG	World	2322	FA1_ReggaeShuffle_XS	4/4	1	90		○	:
GIMG	World	2323	FB1_ReggaeShuffle_XS	4/4	1	90		○	:
GIMG	World	2324	FC1_ReggaeShuffle_XS	4/4	1	90		○	:
GIMG	World	2325	BA1_ReggaeShuffle_XS	4/4	1	90		○	:
GIMG	World	2326	EA1_ReggaeShuffle_XS	4/4	3	90		○	:
GIMG	World	2327	EB1_ReggaeShuffle_XS	4/4	4	90		○	:
GIMG	World	2328	MA2_ReggaeShuffle_XS	4/4	4	90		○	"Mega 1coil SlapClean"
GIMG	World	2329	MB2_ReggaeShuffle_XS	4/4	4	90		○	:
GIMG	World	2330	MC2_ReggaeShuffle_XS	4/4	4	90		○	:
GIMG	World	2331	FA2_ReggaeShuffle_XS	4/4	1	90		○	:
GIMG	World	2332	FB2_ReggaeShuffle_XS	4/4	1	90		○	:
GIMG	World	2333	FC2_ReggaeShuffle_XS	4/4	1	90		○	:
GIMG	World	2334	BA2_ReggaeShuffle_XS	4/4	1	90		○	:
GIMG	World	2335	EA2_ReggaeShuffle_XS	4/4	3	90		○	:
GIMG	World	2336	EB2_ReggaeShuffle_XS	4/4	4	90		○	:
GIMG	World	2337	MA_Jumbo Reggae_XS	4/4	4	100		○	"Mega 60s Clean"
GIMG	World	2338	MB_Jumbo Reggae_XS	4/4	4	100		○	:
GIMG	World	2339	MC_Jumbo Reggae_XS	4/4	4	100		○	:
GIMG	World	2340	FA_Jumbo Reggae_XS	4/4	1	100		○	:
GIMG	World	2341	FB_Jumbo Reggae_XS	4/4	1	100		○	:
GIMG	World	2342	FC_Jumbo Reggae_XS	4/4	1	100		○	:
GIMG	World	2343	BA_Jumbo Reggae_XS	4/4	1	100		○	:
GIMG	World	2344	EA_Jumbo Reggae_XS	4/4	3	100		○	:
GIMG	World	2345	EB_Jumbo Reggae_XS	4/4	3	100		○	:
GIMG	World	2346	MA_RumbaFlamenc_XS	4/4	4	106		○	"Mega Nylon"
GIMG	World	2347	MB_RumbaFlamenc_XS	4/4	4	106		○	:
GIMG	World	2348	MC_RumbaFlamenc_XS	4/4	4	106		○	:
GIMG	World	2349	FA_RumbaFlamenc_XS	4/4	1	106		○	:
GIMG	World	2350	FB_RumbaFlamenc_XS	4/4	1	106		○	:
GIMG	World	2351	FC_RumbaFlamenc_XS	4/4	1	106		○	:
GIMG	World	2352	BA_RumbaFlamenc_XS	4/4	1	106		○	:
GIMG	World	2353	EA_RumbaFlamenc_XS	4/4	3	106		○	:
GIMG	World	2354	EB_RumbaFlamenc_XS	4/4	3	106		○	:
GIMG	World	2355	MA_ModBluegrass_XS	4/4	4	121		○	"Mega 1coil Old R&R"
GIMG	World	2356	MB_ModBluegrass_XS	4/4	4	121		○	:
GIMG	World	2357	MC_ModBluegrass_XS	4/4	4	121		○	:
GIMG	World	2358	FA_ModBluegrass_XS	4/4	1	121		○	:
GIMG	World	2359	FB_ModBluegrass_XS	4/4	1	121		○	:
GIMG	World	2360	FC_ModBluegrass_XS	4/4	1	121		○	:
GIMG	World	2361	BA_ModBluegrass_XS	4/4	1	121		○	:
GIMG	World	2362	EA_ModBluegrass_XS	4/4	6	121		○	:
GIMG	World	2363	MA_Irish Hymn_XS	3/4	4	70		○	"Mega Steel"
GIMG	World	2364	MB_Irish Hymn_XS	3/4	4	70		○	:
GIMG	World	2365	MC_Irish Hymn_XS	3/4	4	70		○	:
GIMG	World	2366	FA_Irish Hymn_XS	3/4	1	70		○	:
GIMG	World	2367	FB_Irish Hymn_XS	3/4	1	70		○	:
GIMG	World	2368	FC_Irish Hymn_XS	3/4	1	70		○	:
GIMG	World	2369	BA_Irish Hymn_XS	3/4	1	70		○	:
GIMG	World	2370	EA_Irish Hymn_XS	3/4	5	70		○	:
GIMG	World	2371	EB_Irish Hymn_XS	3/4	5	70		○	:
GIMG	World	2372	MA_TurkishEuro1_XS	4/4	4	112		○	:
GIMG	World	2373	MB_TurkishEuro1_XS	4/4	4	112		○	:
GIMG	World	2374	MC_TurkishEuro1_XS	4/4	4	112		○	:
GIMG	World	2375	FA_TurkishEuro1_XS	4/4	1	112		○	:
GIMG	World	2376	FB_TurkishEuro1_XS	4/4	1	112		○	:
GIMG	World	2377	FC_TurkishEuro1_XS	4/4	1	112		○	:
GIMG	World	2378	BA_TurkishEuro1_XS	4/4	1	112		○	:
GIMG	World	2379	EA_TurkishEuro1_XS	4/4	3	112		○	:
Bass	Rock	2380	MA_AlternaRock1_ES	4/4	4	97			Finger Bass
Bass	Rock	2381	MB_AlternaRock1_ES	4/4	4	97			:
Bass	Rock	2382	MC_AlternaRock1_ES	4/4	4	97			:
Bass	Rock	2383	FA_AlternaRock1_ES	4/4	1	97			:
Bass	Rock	2384	FB_AlternaRock1_ES	4/4	1	97			:
Bass	Rock	2385	FC_AlternaRock1_ES	4/4	1	97			:
Bass	Rock	2386	BA_AlternaRock1_ES	4/4	1	97			:
Bass	Rock	2387	MA_AlternaRock2_ES	4/4	4	100			:
Bass	Rock	2388	MB_AlternaRock2_ES	4/4	4	100			:
Bass	Rock	2389	MC_AlternaRock2_ES	4/4	4	100			:
Bass	Rock	2390	FA_AlternaRock2_ES	4/4	1	100			:
Bass	Rock	2391	FB_AlternaRock2_ES	4/4	1	100			:
Bass	Rock	2392	FC_AlternaRock2_ES	4/4	1	100			:
Bass	Rock	2393	BA_AlternaRock2_ES	4/4	1	100			:
Bass	Rock	2394	MA_Xover Rock_ES	4/4	1	100			:
Bass	Rock	2395	MB_Xover Rock_ES	4/4	1	100			:
Bass	Rock	2396	MC_Xover Rock_ES	4/4	2	100			:
Bass	Rock	2397	MD_Xover Rock_ES	4/4	2	100			:
Bass	Rock	2398	IA_Xover Rock_ES	4/4	2	100			:
Bass	Rock	2399	FB_Xover Rock_ES	4/4	1	100			:
Bass	Rock	2400	FC_Xover Rock_ES	4/4	2	100			:
Bass	Rock	2401	MA_8Beat Rock_XS	4/4	4	75			:

Main Category	Sub Category	ARP No.	ARP Name	Time Signature	Length	Original Tempo	Accent	Random SFX	Voice Type
Bass	Rock	2402	MB_8Beat Rock_XS	4/4	4	75			Finger Bass
Bass	Rock	2403	MC_8Beat Rock_XS	4/4	4	75			:
Bass	Rock	2404	FA_8Beat Rock_XS	4/4	1	75			:
Bass	Rock	2405	FB_8Beat Rock_XS	4/4	1	75			:
Bass	Rock	2406	FC_8Beat Rock_XS	4/4	1	75			:
Bass	Rock	2407	BA_8Beat Rock_XS	4/4	1	75			:
Bass	Rock	2408	MA_8Beat Rock_ES	4/4	4	75			:
Bass	Rock	2409	MB_8Beat Rock_ES	4/4	4	75			:
Bass	Rock	2410	MC_8Beat Rock_ES	4/4	4	75			:
Bass	Rock	2411	FA_8Beat Rock_ES	4/4	1	75			:
Bass	Rock	2412	FB_8Beat Rock_ES	4/4	1	75			:
Bass	Rock	2413	FC_8Beat Rock_ES	4/4	1	75			:
Bass	Rock	2414	BA_8Beat Rock_ES	4/4	1	75			:
Bass	Rock	2415	MA_ProgresRock1_XS	4/4	4	110			Synth Bass
Bass	Rock	2416	MB_ProgresRock1_XS	4/4	3	110			:
Bass	Rock	2417	MC_ProgresRock1_XS	4/4	4	110			:
Bass	Rock	2418	FA_ProgresRock1_XS	4/4	1	110			:
Bass	Rock	2419	FB_ProgresRock1_XS	4/4	1	110			:
Bass	Rock	2420	FC_ProgresRock1_XS	4/4	1	110			:
Bass	Rock	2421	BA_ProgresRock1_XS	4/4	1	110			:
Bass	Rock	2422	MA_ProgresRock1_ES	4/4	4	110			:
Bass	Rock	2423	MB_ProgresRock1_ES	4/4	3	110			:
Bass	Rock	2424	MC_ProgresRock1_ES	4/4	4	110			:
Bass	Rock	2425	FA_ProgresRock1_ES	4/4	1	110			:
Bass	Rock	2426	FB_ProgresRock1_ES	4/4	1	110			:
Bass	Rock	2427	FC_ProgresRock1_ES	4/4	1	110			:
Bass	Rock	2428	BA_ProgresRock1_ES	4/4	1	110			:
Bass	Rock	2429	MA_ProgresRock2_XS	4/4	4	120			Finger Bass
Bass	Rock	2430	MB_ProgresRock2_XS	4/4	4	120			:
Bass	Rock	2431	MC_ProgresRock2_XS	4/4	4	120			:
Bass	Rock	2432	FA_ProgresRock2_XS	4/4	1	120			:
Bass	Rock	2433	FB_ProgresRock2_XS	4/4	1	120			:
Bass	Rock	2434	FC_ProgresRock2_XS	4/4	1	120			:
Bass	Rock	2435	BA_ProgresRock2_XS	4/4	1	120			:
Bass	Rock	2436	MA_ProgresRock2_ES	4/4	4	120			:
Bass	Rock	2437	MB_ProgresRock2_ES	4/4	4	120			:
Bass	Rock	2438	MC_ProgresRock2_ES	4/4	4	120			:
Bass	Rock	2439	FA_ProgresRock2_ES	4/4	1	120			:
Bass	Rock	2440	FB_ProgresRock2_ES	4/4	1	120			:
Bass	Rock	2441	FC_ProgresRock2_ES	4/4	1	120			:
Bass	Rock	2442	BA_ProgresRock2_ES	4/4	1	120			:
Bass	Rock	2443	MA_Pick Bass1_ES	4/4	4	120			Pick Bass
Bass	Rock	2444	MA_Pick Bass2_ES	4/4	4	120			:
Bass	Rock	2445	MA_Pick Bass3_ES	4/4	4	120			:
Bass	Rock	2446	MA_Pick Bass4_ES	4/4	4	120			:
Bass	Rock	2447	MA_Pick Bass5_ES	4/4	4	120			:
Bass	PopRk	2448	MA_Guitar Pop 2_ES	4/4	2	90			Finger Bass
Bass	PopRk	2449	MB_Guitar Pop 2_ES	4/4	1	90			:
Bass	PopRk	2450	MC_Guitar Pop 2_ES	4/4	2	90			:
Bass	PopRk	2451	MD_Guitar Pop 2_ES	4/4	2	90			:
Bass	PopRk	2452	FA_Guitar Pop 2_ES	4/4	1	90			:
Bass	PopRk	2453	FB_Guitar Pop 2_ES	4/4	2	90			:
Bass	PopRk	2454	MA_FingerPickin_ES	4/4	1	120			:
Bass	PopRk	2455	MB_FingerPickin_ES	4/4	2	120			:
Bass	PopRk	2456	MC_FingerPickin_ES	4/4	1	120			:
Bass	PopRk	2457	MD_FingerPickin_ES	4/4	1	120			:
Bass	PopRk	2458	FA_FingerPickin_ES	4/4	1	120			:
Bass	PopRk	2459	FB_FingerPickin_ES	4/4	1	120			:
Bass	PopRk	2460	FC_FingerPickin_ES	4/4	1	120			:
Bass	PopRk	2461	MA_Folk Rock_ES	4/4	1	120			:
Bass	PopRk	2462	MC_Folk Rock_ES	4/4	1	120			:
Bass	PopRk	2463	MD_Folk Rock_ES	4/4	1	120			:
Bass	PopRk	2464	FA_Folk Rock_ES	4/4	1	120			:
Bass	PopRk	2465	FB_Folk Rock_ES	4/4	1	120			:
Bass	PopRk	2466	MA_70s Rock_ES	4/4	4	130			:
Bass	PopRk	2467	MC_70s Rock_ES	4/4	2	130			:
Bass	PopRk	2468	MD_70s Rock_ES	4/4	4	130			:
Bass	PopRk	2469	FA_70s Rock_ES	4/4	1	130			:
Bass	PopRk	2470	MA_8Beat Basic_XS	4/4	4	120			:
Bass	PopRk	2471	MB_8Beat Basic_XS	4/4	4	120			:
Bass	PopRk	2472	MC_8Beat Basic_XS	4/4	4	120			:
Bass	PopRk	2473	FA_8Beat Basic_XS	4/4	1	120			:
Bass	PopRk	2474	FB_8Beat Basic_XS	4/4	1	120			:
Bass	PopRk	2475	FC_8Beat Basic_XS	4/4	1	120			:
Bass	PopRk	2476	BA_8Beat Basic_XS	4/4	1	120			:
Bass	PopRk	2477	MA_8Beat Basic_ES	4/4	4	120			:
Bass	PopRk	2478	MB_8Beat Basic_ES	4/4	4	120			:
Bass	PopRk	2479	MC_8Beat Basic_ES	4/4	4	120			:
Bass	PopRk	2480	FA_8Beat Basic_ES	4/4	1	120			:
Bass	PopRk	2481	FB_8Beat Basic_ES	4/4	1	120			:
Bass	PopRk	2482	FC_8Beat Basic_ES	4/4	1	120			:
Bass	PopRk	2483	BA_8Beat Basic_ES	4/4	1	120			:
Bass	PopRk	2484	MA_8Beat Soft_X						

Arpeggio Type List

Main Category	Sub Category	ARP No.	ARP Name	Time Signature	Length	Original Tempo	Accent	Random SFX	Voice Type
Bass	PopRk	2485	MB_8Beat Soft_XS	4/4	4	100			Finger Bass
Bass	PopRk	2486	MC_8Beat Soft_XS	4/4	4	100			:
Bass	PopRk	2487	FA_8Beat Soft_XS	4/4	1	100			:
Bass	PopRk	2488	FB_8Beat Soft_XS	4/4	1	100			:
Bass	PopRk	2489	FC_8Beat Soft_XS	4/4	1	100			:
Bass	PopRk	2490	BA_8Beat Soft_XS	4/4	1	100			:
Bass	PopRk	2491	MA_8Beat Soft_ES	4/4	4	100			:
Bass	PopRk	2492	MB_8Beat Soft_ES	4/4	4	100			:
Bass	PopRk	2493	MC_8Beat Soft_ES	4/4	4	100			:
Bass	PopRk	2494	FA_8Beat Soft_ES	4/4	1	100			:
Bass	PopRk	2495	FB_8Beat Soft_ES	4/4	1	100			:
Bass	PopRk	2496	FC_8Beat Soft_ES	4/4	1	100			:
Bass	PopRk	2497	BA_8Beat Soft_ES	4/4	1	100			:
Bass	PopRk	2498	MA_Soft Rock_ES	4/4	1	120			:
Bass	PopRk	2499	MB_Soft Rock_ES	4/4	1	120			:
Bass	PopRk	2500	MC_Soft Rock_ES	4/4	1	120			:
Bass	PopRk	2501	MD_Soft Rock_ES	4/4	1	120			:
Bass	PopRk	2502	IA_Soft Rock_ES	4/4	1	120			:
Bass	PopRk	2503	FA_Soft Rock_ES	4/4	1	120			:
Bass	PopRk	2504	FB_Soft Rock_ES	4/4	1	120			:
Bass	PopRk	2505	MA_16BeatBasic1_XS	4/4	4	90			Finger/Slap Bass
Bass	PopRk	2506	MB_16BeatBasic1_XS	4/4	4	90			:
Bass	PopRk	2507	MC_16BeatBasic1_XS	4/4	4	90			:
Bass	PopRk	2508	FA_16BeatBasic1_XS	4/4	1	90			:
Bass	PopRk	2509	FB_16BeatBasic1_XS	4/4	1	90			:
Bass	PopRk	2510	FC_16BeatBasic1_XS	4/4	1	90			:
Bass	PopRk	2511	BA_16BeatBasic1_XS	4/4	1	90			:
Bass	PopRk	2512	MA_16BeatBasic1_ES	4/4	4	90			:
Bass	PopRk	2513	MB_16BeatBasic1_ES	4/4	4	90			:
Bass	PopRk	2514	MC_16BeatBasic1_ES	4/4	4	90			:
Bass	PopRk	2515	FA_16BeatBasic1_ES	4/4	1	90			:
Bass	PopRk	2516	FB_16BeatBasic1_ES	4/4	1	90			:
Bass	PopRk	2517	FC_16BeatBasic1_ES	4/4	1	90			:
Bass	PopRk	2518	BA_16BeatBasic1_ES	4/4	1	90			:
Bass	PopRk	2519	MA_16BeatBasic2_XS	4/4	4	77			Synth Bass
Bass	PopRk	2520	MB_16BeatBasic2_XS	4/4	4	77			:
Bass	PopRk	2521	MC_16BeatBasic2_XS	4/4	4	77			:
Bass	PopRk	2522	FA_16BeatBasic2_XS	4/4	1	77			:
Bass	PopRk	2523	FB_16BeatBasic2_XS	4/4	1	77			:
Bass	PopRk	2524	FC_16BeatBasic2_XS	4/4	1	77			:
Bass	PopRk	2525	BA_16BeatBasic2_XS	4/4	1	77			:
Bass	PopRk	2526	MA_16BeatBasic2_ES	4/4	3	77			:
Bass	PopRk	2527	MB_16BeatBasic2_ES	4/4	4	77			:
Bass	PopRk	2528	MC_16BeatBasic2_ES	4/4	4	77			:
Bass	PopRk	2529	FA_16BeatBasic2_ES	4/4	1	77			:
Bass	PopRk	2530	FB_16BeatBasic2_ES	4/4	1	77			:
Bass	PopRk	2531	FC_16BeatBasic2_ES	4/4	1	77			:
Bass	PopRk	2532	BA_16BeatBasic2_ES	4/4	1	77			:
Bass	PopRk	2533	MA_16Beat Pop 2_XS	4/4	4	94			:
Bass	PopRk	2534	MB_16Beat Pop 2_XS	4/4	4	94			:
Bass	PopRk	2535	MC_16Beat Pop 2_XS	4/4	4	94			:
Bass	PopRk	2536	FA_16Beat Pop 2_XS	4/4	1	94			:
Bass	PopRk	2537	FB_16Beat Pop 2_XS	4/4	1	94			:
Bass	PopRk	2538	FC_16Beat Pop 2_XS	4/4	1	94			:
Bass	PopRk	2539	BA_16Beat Pop 2_XS	4/4	1	94			:
Bass	PopRk	2540	MA_16Beat Pop 2_ES	4/4	4	94			:
Bass	PopRk	2541	MB_16Beat Pop 2_ES	4/4	4	94			:
Bass	PopRk	2542	MC_16Beat Pop 2_ES	4/4	4	94			:
Bass	PopRk	2543	FA_16Beat Pop 2_ES	4/4	1	94			:
Bass	PopRk	2544	FB_16Beat Pop 2_ES	4/4	1	94			:
Bass	PopRk	2545	FC_16Beat Pop 2_ES	4/4	1	94			:
Bass	PopRk	2546	BA_16Beat Pop 2_ES	4/4	1	94			:
Bass	PopRk	2547	MA_16Beat Rock_XS	4/4	4	86			:
Bass	PopRk	2548	MB_16Beat Rock_XS	4/4	4	86			:
Bass	PopRk	2549	MC_16Beat Rock_XS	4/4	4	86			:
Bass	PopRk	2550	FA_16Beat Rock_XS	4/4	1	86			:
Bass	PopRk	2551	FB_16Beat Rock_XS	4/4	1	86			:
Bass	PopRk	2552	FC_16Beat Rock_XS	4/4	1	86			:
Bass	PopRk	2553	BA_16Beat Rock_XS	4/4	1	86			:
Bass	PopRk	2554	MA_16Beat Rock_ES	4/4	4	86			:
Bass	PopRk	2555	MB_16Beat Rock_ES	4/4	4	86			:
Bass	PopRk	2556	MC_16Beat Rock_ES	4/4	4	86			:
Bass	PopRk	2557	FA_16Beat Rock_ES	4/4	1	86			:
Bass	PopRk	2558	FB_16Beat Rock_ES	4/4	1	86			:
Bass	PopRk	2559	FC_16Beat Rock_ES	4/4	1	86			:
Bass	PopRk	2560	BA_16Beat Rock_ES	4/4	1	86			:
Bass	PopRk	2561	MA_Piano Club_ES	4/4	2	96			Finger Bass
Bass	PopRk	2562	MB_Piano Club_ES	4/4	2	96			:
Bass	PopRk	2563	MC_Piano Club_ES	4/4	2	96			:
Bass	PopRk	2564	MD_Piano Club_ES	4/4	1	96			:
Bass	PopRk	2565	IA_Piano Club_ES	4/4	2	96			:
Bass	PopRk	2566	FA_Piano Club_ES	4/4	1	96			:
Bass	PopRk	2567	FB_Piano Club_ES	4/4	1	96			:

Main Category	Sub Category	ARP No.	ARP Name	Time Signature	Length	Original Tempo	Accent	Random SFX	Voice Type
Bass	PopRk	2568	FC_Piano Club_ES	4/4	4	96			Finger Bass
Bass	PopRk	2569	MA_Analog Pop_ES	4/4	2	93			Pick Bass
Bass	PopRk	2570	MB_Analog Pop_ES	4/4	2	93			:
Bass	PopRk	2571	MC_Analog Pop_ES	4/4	2	93			:
Bass	PopRk	2572	MD_Analog Pop_ES	4/4	4	93			:
Bass	PopRk	2573	IA_Analog Pop_ES	4/4	2	93			:
Bass	PopRk	2574	FA_Analog Pop_ES	4/4	1	93			:
Bass	PopRk	2575	FB_Analog Pop_ES	4/4	1	93			:
Bass	PopRk	2576	FC_Analog Pop_ES	4/4	2	93			:
Bass	PopRk	2577	MA_6/8 Pop_XS	4/4	4	100			Finger/Slap Bass
Bass	PopRk	2578	MB_6/8 Pop_XS	4/4	4	100			:
Bass	PopRk	2579	MC_6/8 Pop_XS	4/4	4	100			:
Bass	PopRk	2580	FA_6/8 Pop_XS	4/4	1	100			:
Bass	PopRk	2581	FB_6/8 Pop_XS	4/4	1	100			:
Bass	PopRk	2582	FC_6/8 Pop_XS	4/4	1	100			:
Bass	PopRk	2583	BA_6/8 Pop_XS	4/4	1	100			:
Bass	PopRk	2584	EA_6/8 Pop_XS	4/4	3	123			:
Bass	PopRk	2585	MA_6/8 Pop_ES	4/4	4	100			:
Bass	PopRk	2586	MB_6/8 Pop_ES	4/4	4	100			:
Bass	PopRk	2587	MC_6/8 Pop_ES	4/4	4	100			:
Bass	PopRk	2588	FA_6/8 Pop_ES	4/4	1	100			:
Bass	PopRk	2589	FB_6/8 Pop_ES	4/4	1	100			:
Bass	PopRk	2590	FC_6/8 Pop_ES	4/4	1	100			:
Bass	PopRk	2591	BA_6/8 Pop_ES	4/4	1	100			:
Bass	Ballad	2592	MA_Unplugged 3_XS	4/4	4	113			Acoustic Bass
Bass	Ballad	2593	MB_Unplugged 3_XS	4/4	4	113			:
Bass	Ballad	2594	MC_Unplugged 3_XS	4/4	4	113			:
Bass	Ballad	2595	FA_Unplugged 3_XS	4/4	1	113			:
Bass	Ballad	2596	FB_Unplugged 3_XS	4/4	1	113			:
Bass	Ballad	2597	FC_Unplugged 3_XS	4/4	1	113			:
Bass	Ballad	2598	BA_Unplugged 3_XS	4/4	1	113			:
Bass	Ballad	2599	MA_Unplugged 3_ES	4/4	4	113			:
Bass	Ballad	2600	MB_Unplugged 3_ES	4/4	4	113			:
Bass	Ballad	2601	MC_Unplugged 3_ES	4/4	4	113			:
Bass	Ballad	2602	FA_Unplugged 3_ES	4/4	1	113			:
Bass	Ballad	2603	FB_Unplugged 3_ES	4/4	1	113			:
Bass	Ballad	2604	FC_Unplugged 3_ES	4/4	1	113			:
Bass	Ballad	2605	BA_Unplugged 3_ES	4/4	1	113			:
Bass	Ballad	2606	MA_8Beat Slow_XS	4/4	4	78			Finger Bass
Bass	Ballad	2607	MB_8Beat Slow_XS	4/4	4	78			:
Bass	Ballad	2608	MC_8Beat Slow_XS	4/4	4	78			:
Bass	Ballad	2609	FA_8Beat Slow_XS	4/4	1	78			:
Bass	Ballad	2610	FB_8Beat Slow_XS	4/4	1	78			:
Bass	Ballad	2611	FC_8Beat Slow_XS	4/4	1	78			:
Bass	Ballad	2612	BA_8Beat Slow_XS	4/4	1	78			:
Bass	Ballad	2613	MA_8Beat Slow_ES	4/4	4	78			:
Bass	Ballad	2614	MB_8Beat Slow_ES	4/4	4	78			:
Bass	Ballad	2615	MC_8Beat Slow_ES	4/4	4	78			:
Bass	Ballad	2616	FA_8Beat Slow_ES	4/4	1	78			:
Bass	Ballad	2617	FB_8Beat Slow_ES	4/4	1	78			:
Bass	Ballad	2618	FC_8Beat Slow_ES	4/4	1	78			:
Bass	Ballad	2619	BA_8Beat Slow_ES	4/4	1	78			:
Bass	Ballad	2620	MA_Slowfeel_ES	4/4	1	74			Fretless Bass
Bass	Ballad	2621	MB_Slowfeel_ES	4/4	1	74			:
Bass	Ballad	2622	MC_Slowfeel_ES	4/4	1	74			:
Bass	Ballad	2623	MD_Slowfeel_ES	4/4	1	74			:
Bass	Ballad	2624	IA_Slowfeel_ES	4/4	2	74			:
Bass	Ballad	2625	FA_Slowfeel_ES	4/4	1	74			:
Bass	Ballad	2626	FB_Slowfeel_ES	4/4	1	74			:
Bass	Ballad	2627	FC_Slowfeel_ES	4/4	2	74			:
Bass	Ballad	2628	MA_16Bt Ballad1_XS	4/4	4	75			Finger Bass
Bass	Ballad	2629	MB_16Bt Ballad1_XS	4/4	4	75			:
Bass	Ballad	2630	MC_16Bt Ballad1_XS	4/4	4	75			:
Bass	Ballad	2631	FA_16Bt Ballad1_XS	4/4	1	75			:
Bass	Ballad	2632	FB_16Bt Ballad1_XS	4/4	1	75			:
Bass	Ballad	2633	FC_16Bt Ballad1_XS	4/4	1	75			:
Bass	Ballad	2634	BA_16Bt Ballad1_XS	4/4	1	75			:
Bass	Ballad	2635	MA_16Bt Ballad1_ES	4/4	4	75			:
Bass	Ballad	2636	MB_16Bt Ballad1_ES	4/4	4	75			:
Bass	Ballad	2637	MC_16Bt Ballad1_ES	4/4	4	75			:
Bass	Ballad	2638	FA_16Bt Ballad1_ES	4/4	1	75			:
Bass	Ballad	2639	FB_16Bt Ballad1_ES	4/4	1	75			:
Bass	Ballad	2640	FC_16Bt Ballad1_ES	4/4	1	75			:
Bass	Ballad	2641	BA_16Bt Ballad1_ES	4/4	1	75			:
Bass	Ballad	2642	MA_6/8 Ballad_XS	6/8	4	87			Finger/Slap Bass
Bass	Ballad	2643	MB_6/8 Ballad_XS	6/8	4	87			:
Bass	Ballad	2644	MC_6/8 Ballad_XS	6/8	4	87			:
Bass	Ballad	2645	FA_6/8 Ballad_XS	6/8	1	87			:
Bass	Ballad	2646	FB_6/8 Ballad_XS	6/8	1	87			:
Bass	Ballad	2647	FC_6/8 Ballad_XS	6/8	1	87			:
Bass	Ballad	2648	BA_6/8 Ballad_XS	6/8	1</				

Arpeggio Type List

Main Category	Sub Category	ARP No.	ARP Name	Time Signature	Length	Original Tempo	Accent	Random SFX	Voice Type
Bass	Balad	2651	MA_6/8 Ballad_ES	6/8	4	87			Finger/Slap Bass
Bass	Balad	2652	MB_6/8 Ballad_ES	6/8	4	87			:
Bass	Balad	2653	MC_6/8 Ballad_ES	6/8	4	87			:
Bass	Balad	2654	FA_6/8 Ballad_ES	6/8	1	87			:
Bass	Balad	2655	FB_6/8 Ballad_ES	6/8	1	87			:
Bass	Balad	2656	FC_6/8 Ballad_ES	6/8	1	87			:
Bass	Balad	2657	BA_6/8 Ballad_ES	6/8	1	87			:
Bass	HipHp	2658	MA_2BZ4U_XS	4/4	4	75			Synth Bass
Bass	HipHp	2659	MB_2BZ4U_XS	4/4	4	75			:
Bass	HipHp	2660	MC_2BZ4U_XS	4/4	4	75			:
Bass	HipHp	2661	MA_2BZ4U_ES	4/4	4	75			:
Bass	HipHp	2662	MB_2BZ4U_ES	4/4	4	75			:
Bass	HipHp	2663	MC_2BZ4U_ES	4/4	4	75			:
Bass	HipHp	2664	MA_DirtySynth_XS	4/4	4	85			:
Bass	HipHp	2665	MB_DirtySynth_XS	4/4	4	85			:
Bass	HipHp	2666	MC_DirtySynth_XS	4/4	4	85			:
Bass	HipHp	2667	MA_DirtySynth_ES	4/4	4	85			:
Bass	HipHp	2668	MB_DirtySynth_ES	4/4	4	85			:
Bass	HipHp	2669	MC_DirtySynth_ES	4/4	4	85			:
Bass	HipHp	2670	MA_PepRally_XS	4/4	2	75			:
Bass	HipHp	2671	MB_PepRally_XS	4/4	2	75			:
Bass	HipHp	2672	MC_PepRally_XS	4/4	2	75			:
Bass	HipHp	2673	MD_PepRally_XS	4/4	2	75			:
Bass	HipHp	2674	ME_PepRally_XS	4/4	2	75			:
Bass	HipHp	2675	MA_PepRally	4/4	2	75			:
Bass	HipHp	2676	MB_PepRally	4/4	2	75			:
Bass	HipHp	2677	MC_PepRally	4/4	2	75			:
Bass	HipHp	2678	MD_PepRally	4/4	2	75			:
Bass	HipHp	2679	ME_PepRally	4/4	2	75			:
Bass	HipHp	2680	MA_HipHopEpic_XS	4/4	2	85			:
Bass	HipHp	2681	MB_HipHopEpic_XS	4/4	2	85			:
Bass	HipHp	2682	MC_HipHopEpic_XS	4/4	2	85			:
Bass	HipHp	2683	MA_HipHopEpic_ES	4/4	2	85			:
Bass	HipHp	2684	MB_HipHopEpic_ES	4/4	2	85			:
Bass	HipHp	2685	MC_HipHopEpic_ES	4/4	2	85			:
Bass	HipHp	2686	MA_New Hip Hop_XS	4/4	2	85			:
Bass	HipHp	2687	MB_New Hip Hop_XS	4/4	2	85			:
Bass	HipHp	2688	MC_New Hip Hop_XS	4/4	2	85			:
Bass	HipHp	2689	FA_New Hip Hop_XS	4/4	1	85			:
Bass	HipHp	2690	FB_New Hip Hop_XS	4/4	1	85			:
Bass	HipHp	2691	FC_New Hip Hop_XS	4/4	1	85			:
Bass	HipHp	2692	BA_New Hip Hop_XS	4/4	1	85			:
Bass	HipHp	2693	EA_New Hip Hop_XS	4/4	3	85			:
Bass	HipHp	2694	EB_New Hip Hop_XS	4/4	3	85			:
Bass	HipHp	2695	MA_East Coast_XS	4/4	2	103			:
Bass	HipHp	2696	MB_East Coast_XS	4/4	2	103			:
Bass	HipHp	2697	MC_East Coast_XS	4/4	2	103			:
Bass	HipHp	2698	MD_East Coast_XS	4/4	2	103			:
Bass	HipHp	2699	MA_East Coast_ES	4/4	2	103			:
Bass	HipHp	2700	MB_East Coast_ES	4/4	2	103			:
Bass	HipHp	2701	MC_East Coast_ES	4/4	2	103			:
Bass	HipHp	2702	MD_East Coast_ES	4/4	2	103			:
Bass	HipHp	2703	MA_West Coast_XS	4/4	2	97			:
Bass	HipHp	2704	MB_West Coast_XS	4/4	2	97			:
Bass	HipHp	2705	MC_West Coast_XS	4/4	2	97			:
Bass	HipHp	2706	MD_West Coast_XS	4/4	2	97			:
Bass	HipHp	2707	MA_West Coast_ES	4/4	2	97			:
Bass	HipHp	2708	MB_West Coast_ES	4/4	2	97			:
Bass	HipHp	2709	MC_West Coast_ES	4/4	2	97			:
Bass	HipHp	2710	MD_West Coast_ES	4/4	2	97			:
Bass	HipHp	2711	MA_South Rap 1_XS	4/4	4	98			:
Bass	HipHp	2712	MB_South Rap 1_XS	4/4	4	98			:
Bass	HipHp	2713	MC_South Rap 1_XS	4/4	4	98			:
Bass	HipHp	2714	MD_South Rap 1_XS	4/4	4	98			:
Bass	HipHp	2715	MA_South Rap 1_ES	4/4	4	98			:
Bass	HipHp	2716	MB_South Rap 1_ES	4/4	4	98			:
Bass	HipHp	2717	MC_South Rap 1_ES	4/4	4	98			:
Bass	HipHp	2718	MD_South Rap 1_ES	4/4	4	98			:
Bass	HipHp	2719	MA_South Rap 2_XS	4/4	2	90			:
Bass	HipHp	2720	MB_South Rap 2_XS	4/4	2	90			:
Bass	HipHp	2721	MC_South Rap 2_XS	4/4	2	90			:
Bass	HipHp	2722	MD_South Rap 2_XS	4/4	2	90			:
Bass	HipHp	2723	MA_South Rap 2_ES	4/4	2	90			:
Bass	HipHp	2724	MB_South Rap 2_ES	4/4	2	90			:
Bass	HipHp	2725	MC_South Rap 2_ES	4/4	2	90			:
Bass	HipHp	2726	MD_South Rap 2_ES	4/4	2	90			:
Bass	HipHp	2727	MA_Hip Hop 1_ES	4/4	2	105			:
Bass	HipHp	2728	MB_Hip Hop 1_ES	4/4	2	105			:
Bass	HipHp	2729	MC_Hip Hop 1_ES	4/4	2	105			:
Bass	HipHp	2730	MD_Hip Hop 1_ES	4/4	2	105			:
Bass	HipHp	2731	FA_Hip Hop 1_ES	4/4	1	105			:
Bass	HipHp	2732	FB_Hip Hop 1_ES	4/4	1	105			:
Bass	HipHp	2733	FC_Hip Hop 1_ES	4/4	2	105			:

Main Category	Sub Category	ARP No.	ARP Name	Time Signature	Length	Original Tempo	Accent	Random SFX	Voice Type
Bass	HipHp	2734	MA_Hip Hop 2	4/4	2	94			Synth Bass
Bass	HipHp	2735	MB_Hip Hop 2	4/4	2	94			:
Bass	HipHp	2736	MC_Hip Hop 2	4/4	2	94			:
Bass	HipHp	2737	MD_Hip Hop 2_ES	4/4	2	94			:
Bass	HipHp	2738	FA_Hip Hop 2	4/4	1	94			:
Bass	HipHp	2739	FB_Hip Hop 2_ES	4/4	1	94			:
Bass	HipHp	2740	FC_Hip Hop 2_ES	4/4	2	94			:
Bass	HipHp	2741	MA_Hip Hop 3_ES	4/4	2	104			:
Bass	HipHp	2742	MB_Hip Hop 3_ES	4/4	2	104			:
Bass	HipHp	2743	MC_Hip Hop 3_ES	4/4	2	104			:
Bass	HipHp	2744	MD_Hip Hop 3_ES	4/4	2	104			:
Bass	HipHp	2745	FC_Hip Hop 3_ES	4/4	2	104			:
Bass	HipHp	2746	MA_Hip Hop 5_XS	4/4	2	103			:
Bass	HipHp	2747	MB_Hip Hop 5_XS	4/4	4	103			:
Bass	HipHp	2748	MC_Hip Hop 5_XS	4/4	2	103			:
Bass	HipHp	2749	MD_Hip Hop 5_XS	4/4	2	103			:
Bass	HipHp	2750	MA_Hip Hop 5_ES	4/4	2	103			:
Bass	HipHp	2751	MB_Hip Hop 5_ES	4/4	4	103			:
Bass	HipHp	2752	MC_Hip Hop 5_ES	4/4	2	103			:
Bass	HipHp	2753	MD_Hip Hop 5_ES	4/4	2	103			:
Bass	HipHp	2754	MA_Hip Hop 6_XS	4/4	4	96			:
Bass	HipHp	2755	MB_Hip Hop 6_XS	4/4	4	96			:
Bass	HipHp	2756	MC_Hip Hop 6_XS	4/4	4	96			:
Bass	HipHp	2757	FA_Hip Hop 6_XS	4/4	1	96			:
Bass	HipHp	2758	FB_Hip Hop 6_XS	4/4	1	96			:
Bass	HipHp	2759	FC_Hip Hop 6_XS	4/4	1	96			:
Bass	HipHp	2760	BA_Hip Hop 6_XS	4/4	1	96			:
Bass	HipHp	2761	MA_Hip Break_XS	4/4	4	98			:
Bass	HipHp	2762	MB_Hip Break_XS	4/4	4	98			:
Bass	HipHp	2763	MC_Hip Break_XS	4/4	4	98			:
Bass	HipHp	2764	FA_Hip Break_XS	4/4	1	98			:
Bass	HipHp	2765	FB_Hip Break_XS	4/4	1	98			:
Bass	HipHp	2766	FC_Hip Break_XS	4/4	1	98			:
Bass	HipHp	2767	BA_Hip Break_XS	4/4	1	98			:
Bass	HipHp	2768	MA_Hip Rock 1_XS	4/4	4	90			:
Bass	HipHp	2769	MB_Hip Rock 1_XS	4/4	4	90			:
Bass	HipHp	2770	MC_Hip Rock 1_XS	4/4	4	90			:
Bass	HipHp	2771	FA_Hip Rock 1_XS	4/4	1	90			:
Bass	HipHp	2772	FB_Hip Rock 1_XS	4/4	1	90			:
Bass	HipHp	2773	MA_Hip Rock 2_XS	4/4	4	132			Finger Bass
Bass	HipHp	2774	MB_Hip Rock 2_XS	4/4	4	132			:
Bass	HipHp	2775	MC_Hip Rock 2_XS	4/4	4	132			:
Bass	HipHp	2776	FA_Hip Rock 2_XS	4/4	1	132			:
Bass	HipHp	2777	FB_Hip Rock 2_XS	4/4	1	132			:
Bass	HipHp	2778	FC_Hip Rock 2_XS	4/4	1	132			:
Bass	HipHp	2779	BA_Hip Rock 2_XS	4/4	1	132			:
Bass	HipHp	2780	MA_Hip Reggae_XS	4/4	4	92			Synth Bass
Bass	HipHp	2781	MB_Hip Reggae_XS	4/4	4	92			:
Bass	HipHp	2782	MC_Hip Reggae_XS	4/4	4	92			:
Bass	HipHp	2783	FA_Hip Reggae_XS	4/4	1	92			:
Bass	HipHp	2784	FB_Hip Reggae_XS	4/4	1	92			:
Bass	HipHp	2785	FC_Hip Reggae_XS	4/4	1	92			:
Bass	HipHp	2786	MA_Regeton_XS	4/4	4	98			:
Bass	HipHp	2787	MB_Regeton_XS	4/4	4	98			:
Bass	HipHp	2788	MC_Regeton_XS	4/4	4	98			:
Bass	HipHp	2789	FA_Regeton_XS	4/4	1	98			:
Bass	HipHp	2790	FB_Regeton_XS	4/4	1	98			:
Bass	HipHp	2791	FC_Regeton_XS	4/4	1	98			:
Bass	HipHp	2792	BA_Regeton_XS	4/4	1	98			:
Bass	HipHp	2793	MA_Dancehall_XS	4/4	4	103			:
Bass	HipHp	2794	MB_Dancehall_XS	4/4	4	103			:
Bass	HipHp	2795	MC_Dancehall_XS	4/4	4	103			:
Bass	HipHp	2796	FA_Dancehall_XS	4/4	1	103			:
Bass	HipHp	2797	FB_Dancehall_XS	4/4	1	103			:
Bass	HipHp	2798	FD_Dancehall_XS	4/4	1	103			:
Bass	HipHp	2799	BA_Dancehall_XS	4/4	1	103			:
Bass	HipHp	2800	EA_Dancehall_XS	4/4	3	103			:
Bass	HipHp	2801	MA_ClasticHipHop_ES	4/4	2	90			:
Bass	HipHp	2802	MB_ClasticHipHop_ES	4/4	2	90			:
Bass	HipHp	2803	MC_ClasticHipHop_ES	4/4	2	90			:
Bass	HipHp	2804	MD_ClasticHipHop_ES	4/4	2	90			:
Bass	HipHp	2805	FC_ClasticHipHop_ES	4/4	1	90			:
Bass	HipHp	2806	MA_ElectroHipBs	4/4	4	70			:
Bass	HipHp	2807	MA_GrubbBass	4/4	2	120			:
Bass	R&B-M	2808	MA_Pop Shuffle1_XS	4/4	4	94			Finger/Slap Bass
Bass	R&B-M	2809	MB_Pop Shuffle1_XS	4/4	4	94			:
Bass	R&B-M	2810	MC_Pop Shuffle1_XS	4/4	4	94			:
Bass	R&B-M	2811	FA_Pop Shuffle1_XS	4/4	1	94			:
Bass	R&B-M	2812	FB_Pop Shuffle1_XS	4/4	1	94			:
Bass	R&B-M	2813	FC_Pop Shuffle1_XS	4/4	1	94			:
Bass	R&B-M	2814	BA_Pop Shuffle1_XS	4/4	1	94			:
Bass	R&B-M	2815	MA_Pop Shuffle1_ES	4/4	4	94			:
Bass	R&B-M	2816	MB_Pop Shuffle1_ES	4/4	4	94			:

Arpeggio Type List

Main Category	Sub Category	ARP No.	ARP Name	Time Signature	Length	Original Tempo	Accent	Random SFX	Voice Type
Bass	R&B-M	2817	MC_Pop Shuffle1_ES	4/4	4	94			Finger/Slap Bass
Bass	R&B-M	2818	FA_Pop Shuffle1_ES	4/4	1	94			:
Bass	R&B-M	2819	FB_Pop Shuffle1_ES	4/4	1	94			:
Bass	R&B-M	2820	FC_Pop Shuffle1_ES	4/4	1	94			:
Bass	R&B-M	2821	BA_Pop Shuffle1_ES	4/4	1	94			:
Bass	R&B-M	2822	MA_Pop Shuffle2_XS	4/4	4	80			Pick Bass
Bass	R&B-M	2823	MB_Pop Shuffle2_XS	4/4	4	80			:
Bass	R&B-M	2824	MC_Pop Shuffle2_XS	4/4	4	80			:
Bass	R&B-M	2825	FA_Pop Shuffle2_XS	4/4	1	80			:
Bass	R&B-M	2826	FB_Pop Shuffle2_XS	4/4	1	80			:
Bass	R&B-M	2827	FC_Pop Shuffle2_XS	4/4	1	80			:
Bass	R&B-M	2828	BA_Pop Shuffle2_XS	4/4	1	80			:
Bass	R&B-M	2829	MA_Pop Shuffle2_ES	4/4	4	80			:
Bass	R&B-M	2830	MB_Pop Shuffle2_ES	4/4	4	80			:
Bass	R&B-M	2831	MC_Pop Shuffle2_ES	4/4	4	80			:
Bass	R&B-M	2832	FA_Pop Shuffle2_ES	4/4	1	80			:
Bass	R&B-M	2833	FB_Pop Shuffle2_ES	4/4	1	80			:
Bass	R&B-M	2834	FC_Pop Shuffle2_ES	4/4	1	80			:
Bass	R&B-M	2835	BA_Pop Shuffle2_ES	4/4	1	80			:
Bass	R&B-M	2836	MA_R&B Disco_ES	4/4	2	110			Synth Bass
Bass	R&B-M	2837	MB_R&B Disco_ES	4/4	2	110			:
Bass	R&B-M	2838	MC_R&B Disco_ES	4/4	2	110			:
Bass	R&B-M	2839	MD_R&B Disco_ES	4/4	2	110			:
Bass	R&B-M	2840	FA_R&B Disco_ES	4/4	1	110			:
Bass	R&B-M	2841	FB_R&B Disco_ES	4/4	1	110			:
Bass	R&B-M	2842	FC_R&B Disco_ES	4/4	2	110			:
Bass	R&B-M	2843	MA_Chart R&B_XS	4/4	4	130			:
Bass	R&B-M	2844	MB_Chart R&B_XS	4/4	4	130			:
Bass	R&B-M	2845	MC_Chart R&B_XS	4/4	4	130			:
Bass	R&B-M	2846	FA_Chart R&B_XS	4/4	1	130			:
Bass	R&B-M	2847	FB_Chart R&B_XS	4/4	1	130			:
Bass	R&B-M	2848	FC_Chart R&B_XS	4/4	1	130			:
Bass	R&B-M	2849	BA_Chart R&B_XS	4/4	1	130			:
Bass	R&B-M	2850	EA_Chart R&B_XS	4/4	5	130			:
Bass	R&B-M	2851	EB_Chart R&B_XS	4/4	10	130			:
Bass	R&B-M	2852	MA_ChartPop1_XS	4/4	4	92			:
Bass	R&B-M	2853	MB_ChartPop1_XS	4/4	4	92			:
Bass	R&B-M	2854	MC_ChartPop1_XS	4/4	4	92			:
Bass	R&B-M	2855	FA_ChartPop1_XS	4/4	1	92			:
Bass	R&B-M	2856	FB_ChartPop1_XS	4/4	1	92			:
Bass	R&B-M	2857	FC_ChartPop1_XS	4/4	1	92			:
Bass	R&B-M	2858	BA_ChartPop1_XS	4/4	1	92			:
Bass	R&B-M	2859	EA_ChartPop1_XS	4/4	3	92			:
Bass	R&B-M	2860	EB_ChartPop1_XS	4/4	3	92			:
Bass	R&B-M	2861	MA_ChartPop2_XS	4/4	2	92			:
Bass	R&B-M	2862	MB_ChartPop2_XS	4/4	2	92			:
Bass	R&B-M	2863	MC_ChartPop2_XS	4/4	2	92			:
Bass	R&B-M	2864	MD_ChartPop2_XS	4/4	2	92			:
Bass	R&B-M	2865	MA_ChartPop2_ES	4/4	2	92			:
Bass	R&B-M	2866	MB_ChartPop2_ES	4/4	2	92			:
Bass	R&B-M	2867	MC_ChartPop2_ES	4/4	2	92			:
Bass	R&B-M	2868	MD_ChartPop2_ES	4/4	2	92			:
Bass	R&B-M	2869	MA_R&B_XS	4/4	2	83			:
Bass	R&B-M	2870	MB_R&B_XS	4/4	2	83			:
Bass	R&B-M	2871	MC_R&B_XS	4/4	2	83			:
Bass	R&B-M	2872	FA_R&B_XS	4/4	1	83			:
Bass	R&B-M	2873	FB_R&B_XS	4/4	1	83			:
Bass	R&B-M	2874	FC_R&B_XS	4/4	1	83			:
Bass	R&B-M	2875	BA_R&B_XS	4/4	1	83			:
Bass	R&B-M	2876	EA_R&B_XS	4/4	4	83			:
Bass	R&B-M	2877	EB_R&B_XS	4/4	4	83			:
Bass	R&B-M	2878	MA_New R&B 1_XS	4/4	2	98			:
Bass	R&B-M	2879	MB_New R&B 1_XS	4/4	2	98			:
Bass	R&B-M	2880	MC_New R&B 1_XS	4/4	2	98			:
Bass	R&B-M	2881	MD_New R&B 1_XS	4/4	1	98			:
Bass	R&B-M	2882	FA_New R&B 1_XS	4/4	1	98			:
Bass	R&B-M	2883	FB_New R&B 1_XS	4/4	1	98			:
Bass	R&B-M	2884	FC_New R&B 1_XS	4/4	1	98			:
Bass	R&B-M	2885	BA_New R&B 1_XS	4/4	3	98			:
Bass	R&B-M	2886	EA_New R&B 1_XS	4/4	4	98			:
Bass	R&B-M	2887	EB_New R&B 1_XS	4/4	1	97			:
Bass	R&B-M	2888	MA_New R&B 2	4/4	1	97			:
Bass	R&B-M	2889	MC_New R&B 2	4/4	1	97			:
Bass	R&B-M	2890	MD_New R&B 2	4/4	1	97			:
Bass	R&B-M	2891	IA_New R&B 2	4/4	2	97			:
Bass	R&B-M	2892	FA_New R&B 2	4/4	1	97			:
Bass	R&B-M	2893	FB_New R&B 2	4/4	1	97			:
Bass	R&B-M	2894	FC_New R&B 2	4/4	2	97			:
Bass	R&B-M	2895	MA_New R&B 3_ES	4/4	2	90			:
Bass	R&B-M	2896	MC_New R&B 3_ES	4/4	2	90			:
Bass	R&B-M	2897	MD_New R&B 3_ES	4/4	2	90			:
Bass	R&B-M	2898	IA_New R&B 3_ES	4/4	2	90			:
Bass	R&B-M	2899	FA_New R&B 3_ES	4/4	1	90			:

Main Category	Sub Category	ARP No.	ARP Name	Time Signature	Length	Original Tempo	Accent	Random SFX	Voice Type
Bass	R&B-M	2900	FB_New R&B 3_ES	4/4	1	90			Synth Bass
Bass	R&B-M	2901	FC_New R&B 3_ES	4/4	2	90			:
Bass	R&B-M	2902	MA_Pop R&B_XS	4/4	4	67			:
Bass	R&B-M	2903	MB_Pop R&B_XS	4/4	4	67			:
Bass	R&B-M	2904	MC_Pop R&B_XS	4/4	4	67			:
Bass	R&B-M	2905	FA_Pop R&B_XS	4/4	1	67			:
Bass	R&B-M	2906	FB_Pop R&B_XS	4/4	1	67			:
Bass	R&B-M	2907	FC_Pop R&B_XS	4/4	1	67			:
Bass	R&B-M	2908	BA_Pop R&B_XS	4/4	1	67			:
Bass	R&B-M	2909	MA_H-R&B Pop_XS	4/4	4	140			:
Bass	R&B-M	2910	MB_H-R&B Pop_XS	4/4	4	140			:
Bass	R&B-M	2911	MC_H-R&B Pop_XS	4/4	4	140			:
Bass	R&B-M	2912	FA_H-R&B Pop_XS	4/4	1	140			:
Bass	R&B-M	2913	FB_H-R&B Pop_XS	4/4	1	140			:
Bass	R&B-M	2914	BA_H-R&B Pop_XS	4/4	1	140			:
Bass	R&B-M	2915	MA_J-R&B Pop_XS	4/4	4	100			:
Bass	R&B-M	2916	MB_J-R&B Pop_XS	4/4	4	100			:
Bass	R&B-M	2917	MC_J-R&B Pop_XS	4/4	4	100			:
Bass	R&B-M	2918	FA_J-R&B Pop_XS	4/4	1	100			:
Bass	R&B-M	2919	FB_J-R&B Pop_XS	4/4	1	100			:
Bass	R&B-M	2920	FC_J-R&B Pop_XS	4/4	1	100			:
Bass	R&B-M	2921	MA_R&B Ana Pop_XS	4/4	4	95			:
Bass	R&B-M	2922	MB_R&B Ana Pop_XS	4/4	4	95			:
Bass	R&B-M	2923	MC_R&B Ana Pop_XS	4/4	4	95			:
Bass	R&B-M	2924	FA_R&B Ana Pop_XS	4/4	1	95			:
Bass	R&B-M	2925	FB_R&B Ana Pop_XS	4/4	1	95			:
Bass	R&B-M	2926	FC_R&B Ana Pop_XS	4/4	1	95			:
Bass	R&B-M	2927	BA_R&B Ana Pop_XS	4/4	1	95			:
Bass	R&B-M	2928	MA_R&B Ballad 1_XS	4/4	4	70			:
Bass	R&B-M	2929	MB_R&B Ballad 1_XS	4/4	4	70			:
Bass	R&B-M	2930	MC_R&B Ballad 1_XS	4/4	4	70			:
Bass	R&B-M	2931	FA_R&B Ballad 1_XS	4/4	1	70			:
Bass	R&B-M	2932	FB_R&B Ballad 1_XS	4/4	1	70			:
Bass	R&B-M	2933	FC_R&B Ballad 1_XS	4/4	1	70			:
Bass	R&B-M	2934	BA_R&B Ballad 1_XS	4/4	1	70			:
Bass	R&B-M	2935	MA_R&B Ballad 2_XS	4/4	2	60			:
Bass	R&B-M	2936	MB_R&B Ballad 2_XS	4/4	2	60			:
Bass	R&B-M	2937	MC_R&B Ballad 2_XS	4/4	2	60			:
Bass	R&B-M	2938	MD_R&B Ballad 2_XS	4/4	2	60			:
Bass	R&B-M	2939	FA_R&B Ballad 2_ES	4/4	2	60			:
Bass	R&B-M	2940	FB_R&B Ballad 2_ES	4/4	2	60			:
Bass	R&B-M	2941	MC_R&B Ballad 2_ES	4/4	2	60			:
Bass	R&B-M	2942	MD_R&B Ballad 2_ES	4/4	2	60			:
Bass	R&B-M	2943	MA_R&B Ballad 3_XS	4/4	4	113			:
Bass	R&B-M	2944	MB_R&B Ballad 3_XS	4/4	4	113			:
Bass	R&B-M	2945	MC_R&B Ballad 3_XS	4/4	4	113			:
Bass	R&B-M	2946	FA_R&B Ballad 3_XS	4/4	1	113			:
Bass	R&B-M	2947	FB_R&B Ballad 3_XS	4/4	1	113			:
Bass	R&B-M	2948	FC_R&B Ballad 3_XS	4/4	1	113			:
Bass	R&B-M	2949	BA_R&B Ballad 3_XS	4/4	1	113			:
Bass	R&B-M	2950	MA_6/8 R&B_ES	4/4	2	61			:
Bass	R&B-M	2951	MC_6/8 R&B_ES	4/4	2	61			:
Bass	R&B-M	2952	MD_6/8 R&B_ES	4/4	2	61			:
Bass	R&B-M	2953	FA_6/8 R&B_ES	4/4	1	61			:
Bass	R&B-M	2954	FB_6/8 R&B_ES	4/4	1	61			:
Bass	R&B-M	2955	FC_6/8 R&B_ES	4/4	2	61			:
Bass	R&B-M	2956	MA_Smooth 1_ES	4/4	2	115			:
Bass	R&B-M	2957	MB_Smooth 1_ES	4/4	2	115			:
Bass	R&B-M	2958	MC_Smooth 1_ES	4/4	2	115			:
Bass	R&B-M	2959	MD_Smooth 1_ES	4/4	2	115			:
Bass	R&B-M	2960	FA_Smooth 1_ES	4/4	1	115			:
Bass	R&B-M	2961	FB_Smooth 1_ES	4/4	1	115			:
Bass	R&B-M	2962	FC_Smooth 1_ES	4/4	2	115			:
Bass	R&B-M	2963	MA_Flip Hop 1_ES	4/4	2	132			Finger Bass
Bass	R&B-M	2964	MB_Flip Hop 1_ES	4/4	2	132			:
Bass	R&B-M	2965	MC_Flip Hop 1_ES	4/4	2	132			:
Bass	R&B-M	2966	MD_Flip Hop 1_ES	4/4	2	132			:
Bass	R&B-M	2967	IA_Flip Hop 1_ES	4/4	2	132			:
Bass	R&B-M	2968	MA_New Gospel_ES	4/4	2	90			Synth Bass
Bass	R&B-M	2969	MB_New Gospel_ES	4/4	2	90			:
Bass	R&B-M	2970	MC_New Gospel_ES	4/4	2	90			:
Bass	R&B-M	2971	MD_New Gospel_ES	4/4	2	90			:
Bass	R&B-M	2972	FA_New Gospel_ES	4/4	1	90			:
Bass	R&B-M	2973	FB_New Gospel_ES	4/4	2	90			:
Bass	R&B-C	2974	MA_Soul 2_ES	4/4	4	120			Finger Bass
Bass	R&B-C	2975	MB_Soul 2_ES	4/4	1	120			:
Bass	R&B-C	2976	MC_Soul 2_ES	4/4	4				

Main Category	Sub Category	ARP No.	ARP Name	Time Signature	Length	Original Tempo	Accent	Random SFX	Voice Type
Bass	R&B-C	2983	MB_Soul 3_ES	4/4	4	88			Synth Bass
Bass	R&B-C	2984	MC_Soul 3_ES	4/4	4	88			:
Bass	R&B-C	2985	MD_Soul 3_ES	4/4	4	88			:
Bass	R&B-C	2986	MA_Soul Beat_XS	4/4	4	124			Finger Bass
Bass	R&B-C	2987	MB_Soul Beat_XS	4/4	4	124			:
Bass	R&B-C	2988	MC_Soul Beat_XS	4/4	4	124			:
Bass	R&B-C	2989	FA_Soul Beat_XS	4/4	1	124			:
Bass	R&B-C	2990	FB_Soul Beat_XS	4/4	1	124			:
Bass	R&B-C	2991	FC_Soul Beat_XS	4/4	1	124			:
Bass	R&B-C	2992	BA_Soul Beat_XS	4/4	1	124			:
Bass	R&B-C	2993	EA_Soul Beat_XS	4/4	3	123			:
Bass	R&B-C	2994	EB_Soul Beat_XS	4/4	3	123			:
Bass	Funk	2995	MA_Funk 3_ES	4/4	2	132			:
Bass	Funk	2996	MB_Funk 3_ES	4/4	2	132			:
Bass	Funk	2997	MC_Funk 3_ES	4/4	4	132			:
Bass	Funk	2998	MD_Funk 3_ES	4/4	4	132			:
Bass	Funk	2999	IA_Funk 3_ES	4/4	1	132			:
Bass	Funk	3000	FB_Funk 3_ES	4/4	1	132			:
Bass	Funk	3001	MA1_Cool Funk_ES	4/4	2	96			:
Bass	Funk	3002	MB1_Cool Funk_ES	4/4	2	96			:
Bass	Funk	3003	MC1_Cool Funk_ES	4/4	2	96			:
Bass	Funk	3004	MD1_Cool Funk_ES	4/4	4	96			:
Bass	Funk	3005	IA1_Cool Funk_ES	4/4	2	96			:
Bass	Funk	3006	FA1_Cool Funk_ES	4/4	1	96			:
Bass	Funk	3007	FB1_Cool Funk_ES	4/4	1	96			:
Bass	Funk	3008	FC1_Cool Funk_ES	4/4	1	96			:
Bass	Funk	3009	MA2_Cool Funk_ES	4/4	2	96			:
Bass	Funk	3010	MB2_Cool Funk_ES	4/4	2	96			:
Bass	Funk	3011	MC2_Cool Funk_ES	4/4	2	96			:
Bass	Funk	3012	MD2_Cool Funk_ES	4/4	4	96			:
Bass	Funk	3013	IA2_Cool Funk_ES	4/4	2	96			:
Bass	Funk	3014	FA2_Cool Funk_ES	4/4	1	96			:
Bass	Funk	3015	FB2_Cool Funk_ES	4/4	1	96			:
Bass	Funk	3016	FC2_Cool Funk_ES	4/4	1	96			:
Bass	Funk	3017	MA_Jazz Funk 2_ES	4/4	2	120			:
Bass	Funk	3018	MB_Jazz Funk 2_ES	4/4	4	120			:
Bass	Funk	3019	MC_Jazz Funk 2_ES	4/4	4	120			:
Bass	Funk	3020	MD_Jazz Funk 2_ES	4/4	4	120			:
Bass	Funk	3021	FC_Jazz Funk 2_ES	4/4	1	120			:
Bass	Funk	3022	MA_Jazz Funk 3_XS	4/4	4	123			Synth Bass
Bass	Funk	3023	MB_Jazz Funk 3_XS	4/4	4	123			:
Bass	Funk	3024	MC_Jazz Funk 3_XS	4/4	4	123			:
Bass	Funk	3025	MD_Jazz Funk 3_XS	4/4	2	123			:
Bass	Funk	3026	MA_Jazz Funk 3_ES	4/4	4	123			:
Bass	Funk	3027	MB_Jazz Funk 3_ES	4/4	4	123			:
Bass	Funk	3028	MC_Jazz Funk 3_ES	4/4	4	123			:
Bass	Funk	3029	MD_Jazz Funk 3_ES	4/4	2	123			:
Bass	Funk	3030	MA_Club Jazz 1_XS	4/4	4	125			Finger Bass
Bass	Funk	3031	MB_Club Jazz 1_XS	4/4	4	125			:
Bass	Funk	3032	MC_Club Jazz 1_XS	4/4	4	125			:
Bass	Funk	3033	FA_Club Jazz 1_XS	4/4	1	125			:
Bass	Funk	3034	FB_Club Jazz 1_XS	4/4	1	125			:
Bass	Funk	3035	FC_Club Jazz 1_XS	4/4	1	125			:
Bass	Funk	3036	BA_Club Jazz 1_XS	4/4	1	125			:
Bass	Funk	3037	MA_Club Jazz 1_ES	4/4	4	125			:
Bass	Funk	3038	MB_Club Jazz 1_ES	4/4	4	125			:
Bass	Funk	3039	MC_Club Jazz 1_ES	4/4	4	125			:
Bass	Funk	3040	FA_Club Jazz 1_ES	4/4	1	125			:
Bass	Funk	3041	FB_Club Jazz 1_ES	4/4	1	125			:
Bass	Funk	3042	FC_Club Jazz 1_ES	4/4	1	125			:
Bass	Funk	3043	BA_Club Jazz 1_ES	4/4	1	125			:
Bass	Funk	3044	MA_Club Jazz 2_XS	4/4	4	92			:
Bass	Funk	3045	MB_Club Jazz 2_XS	4/4	4	92			:
Bass	Funk	3046	MC_Club Jazz 2_XS	4/4	4	92			:
Bass	Funk	3047	FA_Club Jazz 2_XS	4/4	1	92			:
Bass	Funk	3048	FB_Club Jazz 2_XS	4/4	1	92			:
Bass	Funk	3049	FC_Club Jazz 2_XS	4/4	1	92			:
Bass	Funk	3050	BA_Club Jazz 2_XS	4/4	1	92			:
Bass	Funk	3051	MA_Club Jazz 2_ES	4/4	4	92			:
Bass	Funk	3052	MB_Club Jazz 2_ES	4/4	4	92			:
Bass	Funk	3053	MC_Club Jazz 2_ES	4/4	4	92			:
Bass	Funk	3054	FA_Club Jazz 2_ES	4/4	1	92			:
Bass	Funk	3055	FB_Club Jazz 2_ES	4/4	1	92			:
Bass	Funk	3056	FC_Club Jazz 2_ES	4/4	1	92			:
Bass	Funk	3057	BA_Club Jazz 2_ES	4/4	1	92			:
Bass	Funk	3058	MA_FingerBass1_ES	4/4	1	115			:
Bass	Funk	3059	MA_FingerBass2_ES	4/4	1	115			:
Bass	Funk	3060	MA_FingerBass3_ES	4/4	3	115			:
Bass	Funk	3061	MA_FingerBass4_ES	4/4	1	115			:
Bass	Funk	3062	MA_FingerBass5_ES	4/4	1	115			:
Bass	Funk	3063	MA_FingerBass6_ES	4/4	1	115			:
Bass	Funk	3064	MA_FingerBass7_ES	4/4	2	120			:
Bass	Funk	3065	MA_FingerBass8_ES	4/4	2	150			:

Main Category	Sub Category	ARP No.	ARP Name	Time Signature	Length	Original Tempo	Accent	Random SFX	Voice Type
Bass	Funk	3066	MA_FingerBass9_ES	4/4	2	150			Finger Bass
Bass	Funk	3067	MA_FingerBass10_ES	4/4	2	89			:
Bass	Funk	3068	MA_FingerBass11_ES	4/4	2	89			:
Bass	Funk	3069	MA_FingerBass12_ES	4/4	1	115			:
Bass	Funk	3070	MA_FingerBass13_ES	4/4	1	115			:
Bass	Funk	3071	MA_FingerBass14_ES	4/4	1	115			:
Bass	Funk	3072	MA_FingerBass15_ES	4/4	4	107			:
Bass	Funk	3073	MA_FingerBass16_ES	4/4	4	107			:
Bass	Funk	3074	MA_FingerBass17_ES	4/4	4	107			:
Bass	Funk	3075	MA_FingerBass18_ES	4/4	4	107			:
Bass	Funk	3076	MA_FingerBass19_ES	4/4	4	107			:
Bass	Funk	3077	MA_Slap Bass1	4/4	4	120			Slap Bass
Bass	Funk	3078	MA_Slap Bass2	4/4	2	120			:
Bass	Funk	3079	MA_Slap Bass3_ES	4/4	1	124			:
Bass	Funk	3080	MA_Slap Bass4_ES	4/4	1	124			:
Bass	Funk	3081	MA_Slap Bass5_ES	4/4	2	124			:
Bass	Funk	3082	MA_Slap Bass6_ES	4/4	1	105			:
Bass	Funk	3083	MA_Slap Bass7_ES	4/4	1	105			:
Bass	Funk	3084	MA_Slap Bass8_ES	4/4	1	105			:
Bass	Funk	3085	MA_Slap Bass9_ES	4/4	2	110			:
Bass	Funk	3086	MA_Slap Bass10_ES	4/4	1	110			:
Bass	Funk	3087	MA_Slap Bass11_ES	4/4	1	90			:
Bass	Funk	3088	MA_Slap Bass12_ES	4/4	3	120			:
Bass	Funk	3089	MA_Slap Bass13_ES	4/4	1	120			:
Bass	Tekno	3090	MA_Tekno 1_ES	4/4	4	135			Synth Bass
Bass	Tekno	3091	MB_Tekno 1_ES	4/4	8	135			:
Bass	Tekno	3092	MC_Tekno 1_ES	4/4	8	135			:
Bass	Tekno	3093	FA_Tekno 1_ES	4/4	1	135			:
Bass	Tekno	3094	FB_Tekno 1_ES	4/4	1	135			:
Bass	Tekno	3095	FC_Tekno 1_ES	4/4	1	135			:
Bass	Tekno	3096	BA_Tekno 1_ES	4/4	3	135			:
Bass	Tekno	3097	MA_Tekno 2_ES	4/4	4	137			Finger Bass
Bass	Tekno	3098	MC_Tekno 2_ES	4/4	4	137			Synth Bass
Bass	Tekno	3099	FA_Tekno 2_ES	4/4	1	137			:
Bass	Tekno	3100	FB_Tekno 2_ES	4/4	2	137			Finger Bass
Bass	Tekno	3101	BA_Tekno 2_ES	4/4	4	137			Synth Bass
Bass	Tekno	3102	MA_Trance 1_XS	4/4	8	142			:
Bass	Tekno	3103	MB_Trance 1_XS	4/4	4	142			:
Bass	Tekno	3104	MC_Trance 1_XS	4/4	16	142			:
Bass	Tekno	3105	FA_Trance 1_XS	4/4	2	142			:
Bass	Tekno	3106	FB_Trance 1_XS	4/4	8	142			:
Bass	Tekno	3107	FC_Trance 1_XS	4/4	8	142			:
Bass	Tekno	3108	MA_Trance 1_ES	4/4	8	142			:
Bass	Tekno	3109	MB_Trance 1_ES	4/4	4	142			:
Bass	Tekno	3110	MC_Trance 1_ES	4/4	16	142			:
Bass	Tekno	3111	FA_Trance 1_ES	4/4	2	142			:
Bass	Tekno	3112	FB_Trance 1_ES	4/4	8	142			:
Bass	Tekno	3113	FC_Trance 1_ES	4/4	8	142			:
Bass	Tekno	3114	MA_Trance 2_XS	4/4	8	135			:
Bass	Tekno	3115	MB_Trance 2_XS	4/4	8	135			:
Bass	Tekno	3116	MC_Trance 2_XS	4/4	8	135			:
Bass	Tekno	3117	FA_Trance 2_XS	4/4	1	135			:
Bass	Tekno	3118	FB_Trance 2_XS	4/4	8	135			:
Bass	Tekno	3119	FC_Trance 2_XS	4/4	1	135			:
Bass	Tekno	3120	BA_Trance 2_XS	4/4	1	135			:
Bass	Tekno	3121	MA_Trance 2_ES	4/4	8	135			:
Bass	Tekno	3122	MB_Trance 2_ES	4/4	8	135			:
Bass	Tekno	3123	MC_Trance 2_ES	4/4	8	135			:
Bass	Tekno	3124	FA_Trance 2_ES	4/4	1	135			:
Bass	Tekno	3125	FB_Trance 2_ES	4/4	8	135			:
Bass	Tekno	3126	FC_Trance 2_ES	4/4	1	135			:
Bass	Tekno	3127	BA_Trance 2_ES	4/4	1	135			:
Bass	Tekno	3128	MA_Trance 3_XS	4/4	2	140			:
Bass	Tekno	3129	MB_Trance 3_XS	4/4	2	140			:
Bass	Tekno	3130	MC_Trance 3_XS	4/4	3	140			:
Bass	Tekno	3131	FA_Trance 3_XS	4/4	2	140			:
Bass	Tekno	3132	FB_Trance 3_XS	4/4	2	140			:
Bass	Tekno	3133	FC_Trance 3_XS	4/4	4	140			:
Bass	Tekno	3134	BA_Trance 3_XS	4/4	1	140			:
Bass	Tekno	3135	MA_Trance 3_ES	4/4	2	140			:
Bass	Tekno	3136	MB_Trance 3_ES	4/4	2	140			:
Bass	Tekno	3137	MC_Trance 3_ES	4/4	3	140			:
Bass	Tekno	3138	FA_Trance 3_ES	4/4	2	140			:
Bass	Tekno	3139	FB_Trance 3_ES	4/4	2	140			:
Bass	Tekno	3140	FC_Trance 3_ES	4/4	4	140			:
Bass	Tekno	3141	BA_Trance 3_ES	4/4	1	140			:
Bass	Tekno	3142	MA_Trance 4_XS	4/4	4	130			:
Bass	Tekno	3143	MB_Trance 4_XS	4/4	2	130			:
Bass	Tekno	3144	MC_Trance 4_XS	4/4	4	130			:
Bass	Tekno	3145	FA_Trance 4_XS	4/4	4	130			:
Bass	Tekno	3146	FB_Trance 4_XS	4/4	2	130			:
Bass	Tekno	3147	FC_Trance 4_XS	4/4	4	130			:
Bass	Tekno	3148	BA_Trance 4_XS	4/4	2	130			:

Main Category	Sub Category	ARP No.	ARP Name	Time Signature	Length	Original Tempo	Accent	Random SFX	Voice Type
Bass	Tekno	3149	MA_Trance 4_ES	4/4	4	130			Synth Bass
Bass	Tekno	3150	MB_Trance 4_ES	4/4	2	130			:
Bass	Tekno	3151	MC_Trance 4_ES	4/4	4	130			:
Bass	Tekno	3152	FA_Trance 4_ES	4/4	4	130			:
Bass	Tekno	3153	FB_Trance 4_ES	4/4	2	130			:
Bass	Tekno	3154	FC_Trance 4_ES	4/4	4	130			:
Bass	Tekno	3155	BA_Trance 4_ES	4/4	2	130			:
Bass	Tekno	3156	MA_Trance 5_ES	4/4	1	140			:
Bass	Tekno	3157	FA_Trance 5_ES	4/4	1	140			:
Bass	Tekno	3158	FC_Trance 5_ES	4/4	4	140			:
Bass	Tekno	3159	MA_TranceBassA1_ES	4/4	2	143			:
Bass	Tekno	3160	MA_TranceBassA2_ES	4/4	1	143			:
Bass	Tekno	3161	MA_TranceBassA3_ES	4/4	1	143			:
Bass	Tekno	3162	MA_TranceBassA4_ES	4/4	1	143			:
Bass	Tekno	3163	MA_TranceBassA5_ES	4/4	1	143			:
Bass	Tekno	3164	MA_TranceBassB1	4/4	1	143			:
Bass	Tekno	3165	MA_TranceBassB2_ES	4/4	1	143			:
Bass	Tekno	3166	MA_TranceBassB3_ES	4/4	1	143			:
Bass	Tekno	3167	MA_TranceBassB4_ES	4/4	1	143			:
Bass	Tekno	3168	MA_TranceBassB5_ES	4/4	1	143			:
Bass	Tekno	3169	MA_Trance Vision	4/4	1	134			:
Bass	Tekno	3170	MB_Trance Vision	4/4	1	134			:
Bass	Tekno	3171	MC_Trance Vision	4/4	1	134			:
Bass	Tekno	3172	MD_Trance Vision	4/4	1	134			:
Bass	Tekno	3173	MA_Dream Trance	4/4	1	140			:
Bass	Tekno	3174	MB_Dream Trance	4/4	1	140			:
Bass	Tekno	3175	MC_Dream Trance	4/4	1	140			:
Bass	Tekno	3176	MA_Electrix	4/4	1	119			:
Bass	Tekno	3177	MB_Electrix	4/4	1	119			:
Bass	Tekno	3178	MC_Electrix	4/4	1	119			:
Bass	Tekno	3179	MA_Cool Breakz	4/4	1	116			:
Bass	Tekno	3180	MB_Cool Breakz	4/4	1	116			:
Bass	Tekno	3181	MA_Synthlines	4/4	1	124			:
Bass	Tekno	3182	MB_Synthlines	4/4	1	124			:
Bass	Tekno	3183	MC_Synthlines	4/4	1	124			:
Bass	Tekno	3184	MA_Noise Xpress	4/4	4	70			:
Bass	Tekno	3185	MA_Tek Bass1	4/4	1	138			:
Bass	Tekno	3186	MA_Tek Bass2	4/4	1	138			:
Bass	Tekno	3187	MA_Tek Bass3	4/4	8	138			:
Bass	Tekno	3188	MA_Acid Bass1	4/4	1	86			:
Bass	Tekno	3189	MA_Acid Bass2	4/4	1	120			:
Bass	Tekno	3190	MA_Acid Flux	4/4	1	130			:
Bass	Tekno	3191	MA_Octaver	4/4	1	120			:
Bass	Tekno	3192	MA_Twister	4/4	1	135			:
Bass	Tekno	3193	MA_Cyborg	4/4	1	90			:
Bass	Tekno	3194	MA_LoRidr	4/4	1	90			:
Bass	Tekno	3195	MA_Kronic	4/4	1	100			:
Bass	Tekno	3196	MA_Triplet	4/4	1	120			:
Bass	Tekno	3197	MA_Tronica	4/4	1	120			:
Bass	Tekno	3198	MA_Wazzo	4/4	1	94			:
Bass	Tekno	3199	MA_Swing Bass	4/4	2	132			:
Bass	Tekno	3200	MA_Synth Bass1_ES	4/4	1	120			:
Bass	Tekno	3201	MA_Synth Bass2_ES	4/4	1	120			:
Bass	Tekno	3202	MA_Synth Bass3_ES	4/4	1	120			:
Bass	Tekno	3203	MA_Synth Bass4_ES	4/4	1	120			:
Bass	Tekno	3204	MA_Synth Bass5_ES	4/4	1	120			:
Bass	House	3205	MA_Dream Dance_ES	4/4	2	136			:
Bass	House	3206	MB_Dream Dance_ES	4/4	1	136			:
Bass	House	3207	MC_Dream Dance_ES	4/4	4	136			:
Bass	House	3208	MD_Dream Dance_ES	4/4	4	136			:
Bass	House	3209	FA_Dream Dance_ES	4/4	1	136			:
Bass	House	3210	MA_Ibiza_ES	4/4	2	135			:
Bass	House	3211	MB_Ibiza_ES	4/4	2	135			:
Bass	House	3212	MC_Ibiza_ES	4/4	2	135			:
Bass	House	3213	MD_Ibiza_ES	4/4	2	135			:
Bass	House	3214	IA_Ibiza_ES	4/4	1	135			:
Bass	House	3215	FC_Ibiza_ES	4/4	4	135			:
Bass	House	3216	MA_Retro Pop_ES	4/4	2	126			:
Bass	House	3217	MA_Disco House_XS	4/4	4	126			:
Bass	House	3218	MB_Disco House_XS	4/4	4	126			:
Bass	House	3219	MC_Disco House_XS	4/4	4	126			:
Bass	House	3220	FA_Disco House_XS	4/4	1	126			:
Bass	House	3221	FB_Disco House_XS	4/4	1	126			:
Bass	House	3222	FC_Disco House_XS	4/4	1	126			:
Bass	House	3223	BA_Disco House_XS	4/4	1	126			:
Bass	House	3224	MA_Club House_ES	4/4	1	128			:
Bass	House	3225	MB_Club House_ES	4/4	1	128			:
Bass	House	3226	MC_Club House_ES	4/4	1	128			:
Bass	House	3227	MD_Club House_ES	4/4	1	128			:
Bass	House	3228	IA_Club House_ES	4/4	1	128			:
Bass	House	3229	FA_Club House_ES	4/4	1	128			:
Bass	House	3230	FB_Club House_ES	4/4	1	128			:
Bass	House	3231	MA_Garage 2_ES	4/4	2	127			:

Main Category	Sub Category	ARP No.	ARP Name	Time Signature	Length	Original Tempo	Accent	Random SFX	Voice Type
Bass	House	3232	MB_Garage 2_ES	4/4	2	127			Synth Bass
Bass	House	3233	MC_Garage 2_ES	4/4	2	127			:
Bass	House	3234	MD_Garage 2_ES	4/4	2	127			:
Bass	House	3235	IA_Garage 2_ES	4/4	2	127			:
Bass	House	3236	FC_Garage 2_ES	4/4	2	127			:
Bass	House	3237	MA_House Bass_ES	4/4	4	120			:
Bass	D&B	3238	MA_Big Beat 1_ES	4/4	4	115			Finger Bass
Bass	D&B	3239	MB_Big Beat 1_ES	4/4	4	115			:
Bass	D&B	3240	MC_Big Beat 1_ES	4/4	4	115			:
Bass	D&B	3241	FA_Big Beat 1_ES	4/4	1	115			:
Bass	D&B	3242	FB_Big Beat 1_ES	4/4	1	115			:
Bass	D&B	3243	FC_Big Beat 1_ES	4/4	1	115			:
Bass	D&B	3244	BA_Big Beat 1_ES	4/4	1	115			:
Bass	D&B	3245	MA_Breakbeats 1_ES	4/4	4	115			Synth Bass
Bass	D&B	3246	MB_Breakbeats 1_ES	4/4	4	115			:
Bass	D&B	3247	MC_Breakbeats 1_ES	4/4	2	115			:
Bass	D&B	3248	FA_Breakbeats 1_ES	4/4	1	115			:
Bass	D&B	3249	FB_Breakbeats 1_ES	4/4	1	115			:
Bass	D&B	3250	FC_Breakbeats 1_ES	4/4	1	115			:
Bass	D&B	3251	BA_Breakbeats 1_ES	4/4	1	115			:
Bass	D&B	3252	MA_Breakbeats 2_ES	4/4	4	88			:
Bass	D&B	3253	MB_Breakbeats 2_ES	4/4	4	88			:
Bass	D&B	3254	MC_Breakbeats 2_ES	4/4	4	88			:
Bass	D&B	3255	FA_Breakbeats 2_ES	4/4	1	88			:
Bass	D&B	3256	FB_Breakbeats 2_ES	4/4	1	88			:
Bass	D&B	3257	FC_Breakbeats 2_ES	4/4	1	88			:
Bass	D&B	3258	BA_Breakbeats 2_ES	4/4	1	88			:
Bass	Chill	3259	MA_Ambient 1_XS	4/4	4	102			:
Bass	Chill	3260	MB_Ambient 1_XS	4/4	4	102			:
Bass	Chill	3261	MC_Ambient 1_XS	4/4	4	102			:
Bass	Chill	3262	FA_Ambient 1_XS	4/4	1	102			:
Bass	Chill	3263	FB_Ambient 1_XS	4/4	1	102			:
Bass	Chill	3264	MA_Ambient 1_ES	4/4	4	102			:
Bass	Chill	3265	MB_Ambient 1_ES	4/4	4	102			:
Bass	Chill	3266	MC_Ambient 1_ES	4/4	4	102			:
Bass	Chill	3267	FA_Ambient 1_ES	4/4	1	102			:
Bass	Chill	3268	FB_Ambient 1_ES	4/4	1	102			:
Bass	Chill	3269	MA_Ambient 2_XS	4/4	4	111			:
Bass	Chill	3270	MB_Ambient 2_XS	4/4	2	111			:
Bass	Chill	3271	MC_Ambient 2_XS	4/4	4	111			:
Bass	Chill	3272	FA_Ambient 2_XS	4/4	1	111			:
Bass	Chill	3273	FB_Ambient 2_XS	4/4	8	111			:
Bass	Chill	3274	FC_Ambient 2_XS	4/4	1	111			:
Bass	Chill	3275	BA_Ambient 2_XS	4/4	2	111			:
Bass	Chill	3276	MA_Ambient 2_ES	4/4	4	111			:
Bass	Chill	3277	MB_Ambient 2_ES	4/4	2	111			:
Bass	Chill	3278	MC_Ambient 2_ES	4/4	4	111			:
Bass	Chill	3279	FA_Ambient 2_ES	4/4	1	111			:
Bass	Chill	3280	FB_Ambient 2_ES	4/4	8	111			:
Bass	Chill	3281	FC_Ambient 2_ES	4/4	1	111			:
Bass	Chill	3282	BA_Ambient 2_ES	4/4	2	111			:
Bass	Chill	3283	MA_Chill Out_ES	4/4	2	79			:
Bass	Chill	3284	MC_Chill Out_ES	4/4	4	79			:
Bass	Chill	3285	MD_Chill Out_ES	4/4	1	79			Finger Bass
Bass	Chill	3286	IA_Chill Out_ES	4/4	3	79			:
Bass	Chill	3287	FA_Chill Out_ES	4/4	1	79			"Finger Bass (PB Range-12)"
Bass	Chill	3288	FB_Chill Out_ES	4/4	4	79			Finger Bass
Bass	Chill	3289	MA_ChillKiBass	4/4	4	70			Synth Bass
Bass	Chill	3290	MA_ClubtechBas1	4/4	1	70			:
Bass	Chill	3291	MA_ClubtechBas2	4/4	1	70			:
Bass	Chill	3292	MA_ClubtechBas3	4/4	1	70			:
Bass	Chill	3293	MA_HeavyChillBs	4/4	4	70			:
Bass	Chill	3294	MA_HeartbreakBs	4/4	4	70			:
Bass	Chill	3295	MA_PopBreaksBas	4/4	4	70			:
Bass	Chill	3296	MB_Synth Pop_ES	4/4	2	90			:
Bass	Chill	3297	MC_Synth Pop_ES	4/4	2	90			:
Bass	Chill	3298	FA_Synth Pop_ES	4/4	2	90			:
Bass	Chill	3299	MA_Eighties	4/4	1	120			:
Bass	Chill	3300	MA_Eighties AF1	4/4	1	120			:
Bass	Chill	3301	MB_Eighties	4/4	1	120			:
Bass	Chill	3302	MC_Eighties AF1	4/4	1	120			:
Bass	Chill	3303	FA_Eighties	4/4	1	120			:
Bass	Chill	3304	FB_Eighties AF1	4/4	1	120			:
Bass	Jazz	3305	MA_AcousticJaz/1_ES	4/4	4	204			Acoustic Bass
Bass	Jazz	3306	MA_AcousticJaz/2_ES	4/4	4	204			:
Bass	Jazz	3307	MA_AcousticJaz/3_ES	4/4	4	204			:
Bass	Jazz	3308	MA_AcousticJaz/4_ES	4/4	4	204			:
Bass	Jazz	3309	MB_AcousticJaz/1_ES	4/4	4	204			:
Bass	Jazz	3310	MC_AcousticJaz/2_ES	4/4	4	204			:
Bass	Jazz	3311	MA_AcousticJaz/3_ES	4/4	4	204			:
Bass	Jazz	3312	MA_AcousticJaz/4_ES	4/4	4	204			:
Bass	Jazz	3313	MC_AcousticJaz/1_ES	4/4	4	204			:
Bass	Jazz	3314	MC_AcousticJaz/2_ES	4/4	4	204			:

Main Category	Sub Category	ARP No.	ARP Name	Time Signature	Length	Original Tempo	Accent	Random SFX	Voice Type
Bass	Jazz	3315	MC_AcousticJaz3_ES	4/4	4	204			Acoustic Bass
Bass	Jazz	3316	MC_AcousticJaz4_ES	4/4	4	204			:
Bass	Jazz	3317	MD_AcousticJaz1_ES	4/4	4	204			:
Bass	Jazz	3318	MD_AcousticJaz2_ES	4/4	4	204			:
Bass	Jazz	3319	MD_AcousticJaz3_ES	4/4	4	204			:
Bass	Jazz	3320	MD_AcousticJaz4_ES	4/4	4	204			:
Bass	Jazz	3321	IA_AcousticJazz_ES	4/4	4	204			:
Bass	Jazz	3322	FA_AcousticJazz_ES	4/4	1	204			:
Bass	Jazz	3323	FB_AcousticJazz_ES	4/4	1	204			:
Bass	Jazz	3324	FC_AcousticJazz_ES	4/4	4	204			:
Bass	Jazz	3325	MA_AcousticBas1_ES	4/4	4	132			:
Bass	Jazz	3326	MA_AcousticBas2_ES	4/4	4	132			:
Bass	Jazz	3327	MA_AcousticBas3_ES	4/4	4	132			:
Bass	Jazz	3328	MA_AcousticBas4_ES	4/4	8	132			:
Bass	Jazz	3329	MA_AcousticBas5_ES	4/4	4	132			:
Bass	Jazz	3330	MA_Walkin	4/4	3	103			:
Bass	Jazz	3331	MA_Slow Blues 2_XS	4/4	4	72			Finger Bass
Bass	Jazz	3332	MB_Slow Blues 2_XS	4/4	4	72			:
Bass	Jazz	3333	MC_Slow Blues 2_XS	4/4	4	72			:
Bass	Jazz	3334	FA_Slow Blues 2_XS	4/4	1	72			:
Bass	Jazz	3335	FB_Slow Blues 2_XS	4/4	1	72			:
Bass	Jazz	3336	FC_Slow Blues 2_XS	4/4	1	72			:
Bass	Jazz	3337	BA_Slow Blues 2_XS	4/4	1	72			:
Bass	Jazz	3338	MA_Slow Blues 2_ES	4/4	4	72			:
Bass	Jazz	3339	MB_Slow Blues 2_ES	4/4	4	72			:
Bass	Jazz	3340	MC_Slow Blues 2_ES	4/4	4	72			:
Bass	Jazz	3341	FA_Slow Blues 2_ES	4/4	1	72			:
Bass	Jazz	3342	FB_Slow Blues 2_ES	4/4	1	72			:
Bass	Jazz	3343	FC_Slow Blues 2_ES	4/4	1	72			:
Bass	Jazz	3344	BA_Slow Blues 2	4/4	1	72			:
Bass	Latin	3345	MA_Salsa 2_ES	4/4	4	123			Acoustic Bass
Bass	Latin	3346	MB_Salsa 2_ES	4/4	4	123			:
Bass	Latin	3347	FA_Salsa 2_ES	4/4	1	123			:
Bass	Latin	3348	FC_Salsa 2_ES	4/4	2	123			:
Bass	Latin	3349	MA_Montuno_ES	4/4	4	100			Finger Bass
Bass	Latin	3350	MC_Montuno/1_ES	4/4	4	100			:
Bass	Latin	3351	MC_Montuno/2_ES	4/4	4	100			:
Bass	Latin	3352	MD_Montuno/1_ES	4/4	4	100			:
Bass	Latin	3353	MD_Montuno/2_ES	4/4	4	100			:
Bass	Latin	3354	MD_Montuno/3_ES	4/4	4	100			:
Bass	Latin	3355	MD_Montuno/4_ES	4/4	4	100			:
Bass	Latin	3356	FA_Montuno/1_ES	4/4	1	100			:
Bass	Latin	3357	FA_Montuno/2_ES	4/4	1	100			:
Bass	Latin	3358	FC_Montuno_ES	4/4	4	100			:
Bass	Latin	3359	MA_Samba_ES	4/4	2	120			:
Bass	Latin	3360	MC_Samba_ES	4/4	4	120			:
Bass	Latin	3361	MD_Samba_ES	4/4	4	120			:
Bass	Latin	3362	IA_Samba_ES	4/4	2	120			:
Bass	Latin	3363	MA_FretlessBas1_ES	4/4	4	124			Fretless Bass
Bass	Latin	3364	MA_FretlessBas2_ES	4/4	4	124			:
Bass	Latin	3365	MA_FretlessBas3_ES	4/4	4	124			:
Bass	Latin	3366	MA_FretlessBas4_ES	4/4	4	124			:
Bass	Latin	3367	MA_FretlessBas5_ES	4/4	4	124			:
Bass	Latin	3368	MA_Latin Rock_ES	4/4	2	120			Finger Bass
Bass	Latin	3369	MB_Latin Rock_ES	4/4	2	120			:
Bass	Latin	3370	MC_Latin Rock_ES	4/4	2	120			:
Bass	Latin	3371	MD_Latin Rock_ES	4/4	4	120			:
Bass	Latin	3372	IA_Latin Rock_ES	4/4	2	120			:
Bass	Latin	3373	FA_Latin Rock_ES	4/4	1	120			:
Bass	Latin	3374	FB_Latin Rock_ES	4/4	1	120			:
Bass	Latin	3375	MA_Disco Latin_XS	4/4	4	100			:
Bass	Latin	3376	MB_Disco Latin_XS	4/4	4	100			:
Bass	Latin	3377	MC_Disco Latin_XS	4/4	4	100			:
Bass	Latin	3378	FA_Disco Latin_XS	4/4	1	100			:
Bass	Latin	3379	FB_Disco Latin_XS	4/4	1	100			:
Bass	Latin	3380	FC_Disco Latin_XS	4/4	1	100			:
Bass	Latin	3381	BA_Disco Latin_XS	4/4	1	100			:
Bass	Latin	3382	MA_Latin House_ES	4/4	4	138			:
Bass	Latin	3383	MC_Latin House_ES	4/4	4	138			:
Bass	Latin	3384	FA_Latin House_ES	4/4	4	138			Synth Bass
Bass	World	3385	MA_Jumbo Reggae_XS	4/4	4	100			:
Bass	World	3386	MB_Jumbo Reggae_XS	4/4	4	100			:
Bass	World	3387	MC_Jumbo Reggae_XS	4/4	4	100			:
Bass	World	3388	FA_Jumbo Reggae_XS	4/4	1	100			:
Bass	World	3389	FB_Jumbo Reggae_XS	4/4	1	100			:
Bass	World	3390	FC_Jumbo Reggae_XS	4/4	1	100			:
Bass	World	3391	BA_Jumbo Reggae_XS	4/4	1	100			:
Bass	World	3392	EA_Jumbo Reggae_XS	4/4	3	100			:
Bass	World	3393	EB_Jumbo Reggae_XS	4/4	3	100			:
Bass	World	3394	MA_Reggae 1	4/4	4	102			Finger Bass
Bass	World	3395	MB_Reggae 1	4/4	4	102			:
Bass	World	3396	MC_Reggae 1	4/4	4	80			:
Bass	World	3397	MD_Reggae 1	4/4	4	90			:

Main Category	Sub Category	ARP No.	ARP Name	Time Signature	Length	Original Tempo	Accent	Random SFX	Voice Type
Bass	World	3398	IA_Reggae 1	4/4	4	102			Finger Bass
Bass	World	3399	FA_Reggae 1	4/4	1	96			:
Bass	World	3400	FB_Reggae 1	4/4	1	90			:
Bass	World	3401	FC_Reggae 1	4/4	4	96			:
Bass	World	3402	MA_Reggae 2_ES	4/4	2	92			:
Bass	World	3403	MB_Reggae 2_ES	4/4	2	92			:
Bass	World	3404	MC_Reggae 2_ES	4/4	2	92			:
Bass	World	3405	MD_Reggae 2_ES	4/4	2	92			:
Bass	World	3406	IA_Reggae 2_ES	4/4	2	92			:
Bass	World	3407	FA_Reggae 2_ES	4/4	1	92			:
Bass	World	3408	FB_Reggae 2_ES	4/4	1	92			:
Bass	World	3409	MA_Spanish Pop_ES	4/4	1	120			:
Bass	World	3410	MB_Spanish Pop_ES	4/4	2	120			:
Bass	World	3411	MC_Spanish Pop_ES	4/4	1	120			:
Bass	World	3412	MD_Spanish Pop_ES	4/4	1	120			:
Bass	World	3413	FA_Spanish Pop_ES	4/4	1	120			:
Bass	World	3414	FC_Spanish Pop_ES	4/4	2	120			:
Bass	World	3415	MA_Turkish Pop_XS	4/4	4	101			Synth Bass
Bass	World	3416	MB_Turkish Pop_XS	4/4	4	101			:
Bass	World	3417	MC_Turkish Pop_XS	4/4	4	101			:
Bass	World	3418	MD_Turkish Pop_XS	4/4	4	101			:
Bass	World	3419	MA_Turkish Pop_ES	4/4	4	101			:
Bass	World	3420	MB_Turkish Pop_ES	4/4	4	101			:
Bass	World	3421	MC_Turkish Pop_ES	4/4	4	101			:
Bass	World	3422	MD_Turkish Pop_ES	4/4	4	101			:
Bass	World	3423	MA_TurkishDance_XS	4/4	4	130			:
Bass	World	3424	MB_TurkishDance_XS	4/4	4	130			:
Bass	World	3425	MC_TurkishDance_XS	4/4	4	130			:
Bass	World	3426	MD_TurkishDance_XS	4/4	4	130			:
Bass	World	3427	MA_TurkishDance_ES	4/4	4	130			:
Bass	World	3428	MB_TurkishDance_ES	4/4	4	130			:
Bass	World	3429	MC_TurkishDance_ES	4/4	4	130			:
Bass	World	3430	MD_TurkishDance_ES	4/4	4	130			:
Bass	World	3431	MA_Turkish_ES	4/4	2	105			Finger Bass
Bass	World	3432	MB_Turkish_ES	4/4	2	105			:
Bass	World	3433	MC_Turkish_ES	9/8	2	125			:
Bass	World	3434	MD_Turkish_ES	9/8	2	125			:
Bass	World	3435	ME_Turkish_ES	4/4	2	105			:
Bass	World	3436	MF_Turkish_ES	4/4	2	105			:
Bass	World	3437	IA_Turkish_ES	4/4	2	86			:
Bass	World	3438	MA_TurkishEuro1_XS	4/4	4	112			Synth Bass
Bass	World	3439	MB_TurkishEuro1_XS	4/4	4	112			:
Bass	World	3440	MC_TurkishEuro1_XS	4/4	4	112			:
Bass	World	3441	FA_TurkishEuro1_XS	4/4	1	112			:
Bass	World	3442	FB_TurkishEuro1_XS	4/4	1	112			:
Bass	World	3443	FC_TurkishEuro1_XS	4/4	1	112			:
Bass	World	3444	BA_TurkishEuro1_XS	4/4	1	112			:
Bass	World	3445	EA_TurkishEuro1_XS	4/4	3	112			:
Bass	World	3446	MA_TurkishEuro2_XS	4/4	4	120			:
Bass	World	3447	MB_TurkishEuro2_XS	4/4	4	120			:
Bass	World	3448	MC_TurkishEuro2_XS	4/4	4	120			:
Bass	World	3449	FA_TurkishEuro2_XS	4/4	1	120			:
Bass	World	3450	FB_TurkishEuro2_XS	4/4	1	120			:
Bass	World	3451	FC_TurkishEuro2_XS	4/4	1	120			:
Bass	World	3452	BA_TurkishEuro2_XS	4/4	1	120			:
Bass	World	3453	EA_TurkishEuro2_XS	4/4	3	120			:
BaMG	Rock	3454	MA_StandardRock_XS	4/4	4	131		O	"Mega Finger+Slap"
BaMG	Rock	3455	MB_StandardRock_XS	4/4	4	131		O	:
BaMG	Rock	3456	MC_StandardRock_XS	4/4	4	131		O	:
BaMG	Rock	3457	FA_StandardRock_XS	4/4	1	131		O	:
BaMG	Rock	3458	FB_StandardRock_XS	4/4	1	131		O	:
BaMG	Rock	3459	FC_StandardRock_XS	4/4	1	131		O	:
BaMG	Rock	3460	BA_StandardRock_XS	4/4	1	131		O	:
BaMG	Rock	3461	EA_StandardRock_XS	4/4	4	131		O	:
BaMG	Rock	3462	EB_StandardRock_XS	4/4	6	131		O	:
BaMG	Rock	3463	MA_Power Rock_XS	4/4	4	120		O	"Mega Pick Open Mute"
BaMG	Rock	3464	MB_Power Rock_XS	4/4	4	120		O	:
BaMG	Rock	3465	MC_Power Rock_XS	4/4	4	120		O	:
BaMG	Rock	3466	FA_Power Rock_XS	4/4	1	120		O	:
BaMG	Rock	3467	FB_Power Rock_XS	4/4	1	120		O	:
BaMG	Rock	3468	FC_Power Rock_XS	4/4	1	120		O	:
BaMG	Rock	3469	BA_Power Rock_XS	4/4	1	120		O	:
BaMG	Rock	3470	EA_Power Rock_XS	4/4	4	120		O	:
BaMG	Rock	3471	EB_Power Rock_XS	4/4	7	120		O	:
BaMG	Rock	3472	MA_ContempRock_XS	4/4	4	126		O	:
BaMG	Rock	3473	MB_ContempRock_XS	4/4	4	126		O	:
BaMG	Rock	3474	MC_ContempRock_XS	4/4	4	126		O	:
BaMG	Rock	3475	FA_ContempRock_XS	4/4	1	126		O	:
BaMG	Rock	3476	FB_ContempRock_XS	4/4	1	126		O	:
BaMG	Rock	3477	FC_ContempRock_XS	4/4	1	126		O	:
BaMG	Rock	3478	BA_ContempRock_XS	4/4	1	126		O	:
BaMG	Rock	3479	EA_ContempRock_XS	4/4	4	126		O	:
BaMG	Rock	3480	EB_ContempRock_XS	4/4	4	126		O	:

Arpeggio Type List

Main Category	Sub Category	ARP No.	ARP Name	Time Signature	Length	Original Tempo	Accent	Random SFX	Voice Type
BaMG	Rock	3481	MA_Hard Rock_XS	4/4	4	120		○	*Mega Finger+Slap
BaMG	Rock	3482	MB_Hard Rock_XS	4/4	4	120		○	:
BaMG	Rock	3483	MC_Hard Rock_XS	4/4	4	120		○	:
BaMG	Rock	3484	FA_Hard Rock_XS	4/4	1	120		○	:
BaMG	Rock	3485	FB_Hard Rock_XS	4/4	1	120		○	:
BaMG	Rock	3486	FC_Hard Rock_XS	4/4	1	120		○	:
BaMG	Rock	3487	BA_Hard Rock_XS	4/4	1	120		○	:
BaMG	Rock	3488	EA_Hard Rock_XS	4/4	3	120		○	:
BaMG	Rock	3489	EB_Hard Rock_XS	4/4	6	120		○	:
BaMG	Rock	3490	MA_Blues Rock_XS	4/4	4	120		○	:
BaMG	Rock	3491	MB_Blues Rock_XS	4/4	4	120		○	:
BaMG	Rock	3492	MC_Blues Rock_XS	4/4	4	120		○	:
BaMG	Rock	3493	FA_Blues Rock_XS	4/4	1	120		○	:
BaMG	Rock	3494	FB_Blues Rock_XS	4/4	1	120		○	:
BaMG	Rock	3495	FC_Blues Rock_XS	4/4	1	120		○	:
BaMG	Rock	3496	BA_Blues Rock_XS	4/4	1	120		○	:
BaMG	Rock	3497	EA_Blues Rock_XS	4/4	3	120		○	:
BaMG	Rock	3498	EB_Blues Rock_XS	4/4	5	120		○	:
BaMG	Rock	3499	MA_RockShuffle_XS	4/4	4	121		○	*Mega Pick Open Mute
BaMG	Rock	3500	MB_RockShuffle_XS	4/4	4	121		○	:
BaMG	Rock	3501	MC_RockShuffle_XS	4/4	4	121		○	:
BaMG	Rock	3502	FA_RockShuffle_XS	4/4	1	121		○	:
BaMG	Rock	3503	FB_RockShuffle_XS	4/4	1	121		○	:
BaMG	Rock	3504	FC_RockShuffle_XS	4/4	1	121		○	:
BaMG	Rock	3505	BA_RockShuffle_XS	4/4	1	121		○	:
BaMG	Rock	3506	EA_RockShuffle_XS	4/4	6	121		○	:
BaMG	Rock	3507	MA_Rock & Roll_XS	4/4	4	172		○	:
BaMG	Rock	3508	MB_Rock & Roll_XS	4/4	4	172		○	:
BaMG	Rock	3509	MC_Rock & Roll_XS	4/4	4	172		○	:
BaMG	Rock	3510	FA_Rock & Roll_XS	4/4	1	172		○	:
BaMG	Rock	3511	FB_Rock & Roll_XS	4/4	1	172		○	:
BaMG	Rock	3512	FC_Rock & Roll_XS	4/4	1	172		○	:
BaMG	Rock	3513	BA_Rock & Roll_XS	4/4	1	172		○	:
BaMG	Rock	3514	EA_Rock & Roll_XS	4/4	5	172		○	:
BaMG	Rock	3515	EB_Rock & Roll_XS	4/4	6	172		○	:
BaMG	Rock	3516	MC_MapleCstmBass_XS	4/4	4	150		○	*Mega Finger+Slap
BaMG	Rock	3517	MD_MapleCstmBass_XS	4/4	4	150		○	:
BaMG	Rock	3518	EA_MapleCstmBass_XS	4/4	7	150		○	:
BaMG	PopRk	3519	MA_Guitar Pop 1_XS	4/4	4	100		○	:
BaMG	PopRk	3520	MB_Guitar Pop 1_XS	4/4	4	100		○	:
BaMG	PopRk	3521	MC_Guitar Pop 1_XS	4/4	4	100		○	:
BaMG	PopRk	3522	FA_Guitar Pop 1_XS	4/4	1	100		○	:
BaMG	PopRk	3523	FB_Guitar Pop 1_XS	4/4	1	100		○	:
BaMG	PopRk	3524	FC_Guitar Pop 1_XS	4/4	1	100		○	:
BaMG	PopRk	3525	BA_Guitar Pop 1_XS	4/4	1	100		○	:
BaMG	PopRk	3526	EA_Guitar Pop 1_XS	4/4	3	100		○	:
BaMG	PopRk	3527	EB_Guitar Pop 1_XS	4/4	3	100		○	:
BaMG	PopRk	3528	MA_Acoustic Pop_XS	4/4	4	110		○	:
BaMG	PopRk	3529	MB_Acoustic Pop_XS	4/4	4	110		○	:
BaMG	PopRk	3530	MC_Acoustic Pop_XS	4/4	4	110		○	:
BaMG	PopRk	3531	FA_Acoustic Pop_XS	4/4	1	110		○	:
BaMG	PopRk	3532	FB_Acoustic Pop_XS	4/4	1	110		○	:
BaMG	PopRk	3533	FC_Acoustic Pop_XS	4/4	1	110		○	:
BaMG	PopRk	3534	MA_Worship Slow_XS	4/4	4	75		○	:
BaMG	PopRk	3535	MB_Worship Slow_XS	4/4	4	75		○	:
BaMG	PopRk	3536	MC_Worship Slow_XS	4/4	4	75		○	:
BaMG	PopRk	3537	FA_Worship Slow_XS	4/4	1	75		○	:
BaMG	PopRk	3538	FB_Worship Slow_XS	4/4	1	75		○	:
BaMG	PopRk	3539	FC_Worship Slow_XS	4/4	1	75		○	:
BaMG	PopRk	3540	BA_Worship Slow_XS	4/4	1	75		○	:
BaMG	PopRk	3541	EA_Worship Slow_XS	4/4	4	75		○	:
BaMG	PopRk	3542	EB_Worship Slow_XS	4/4	4	75		○	:
BaMG	PopRk	3543	MA_Worship Med_XS	4/4	8	140		○	*Mega Acoustic Bass
BaMG	PopRk	3544	MB_Worship Med_XS	4/4	4	140		○	:
BaMG	PopRk	3545	MC_Worship Med_XS	4/4	4	140		○	:
BaMG	PopRk	3546	FA_Worship Med_XS	4/4	1	140		○	:
BaMG	PopRk	3547	FB_Worship Med_XS	4/4	1	140		○	:
BaMG	PopRk	3548	FC_Worship Med_XS	4/4	1	140		○	:
BaMG	PopRk	3549	BA_Worship Med_XS	4/4	1	140		○	:
BaMG	PopRk	3550	EA_Worship Med_XS	4/4	4	140		○	:
BaMG	PopRk	3551	EB_Worship Med_XS	4/4	4	140		○	:
BaMG	PopRk	3552	MA_Worship Fast_XS	4/4	8	114		○	*Mega Finger+Slap
BaMG	PopRk	3553	MB_Worship Fast_XS	4/4	4	114		○	:
BaMG	PopRk	3554	MC_Worship Fast_XS	4/4	4	114		○	:
BaMG	PopRk	3555	FA_Worship Fast_XS	4/4	1	114		○	:
BaMG	PopRk	3556	FB_Worship Fast_XS	4/4	1	114		○	:
BaMG	PopRk	3557	FC_Worship Fast_XS	4/4	1	114		○	:
BaMG	PopRk	3558	BA_Worship Fast_XS	4/4	1	114		○	:
BaMG	PopRk	3559	EA_Worship Fast_XS	4/4	4	114		○	:
BaMG	PopRk	3560	EB_Worship Fast_XS	4/4	2	114		○	:
BaMG	PopRk	3561	MA_New Country_XS	4/4	2	118		○	:
BaMG	PopRk	3562	MB_New Country_XS	4/4	4	118		○	:
BaMG	PopRk	3563	MC_New Country_XS	4/4	2	118		○	:

Main Category	Sub Category	ARP No.	ARP Name	Time Signature	Length	Original Tempo	Accent	Random SFX	Voice Type
BaMG	PopRk	3564	FA_New Country_XS	4/4	1	118		○	*Mega Finger+Slap
BaMG	PopRk	3565	FB_New Country_XS	4/4	1	118		○	:
BaMG	PopRk	3566	FC_New Country_XS	4/4	1	118		○	:
BaMG	PopRk	3567	BA_New Country_XS	4/4	1	118		○	:
BaMG	PopRk	3568	EA_New Country_XS	4/4	4	118		○	:
BaMG	PopRk	3569	EB_New Country_XS	4/4	4	118		○	:
BaMG	PopRk	3570	MA_VintageGPop_XS	4/4	4	148		○	:
BaMG	PopRk	3571	MB_VintageGPop_XS	4/4	4	148		○	:
BaMG	PopRk	3572	MC_VintageGPop_XS	4/4	4	148		○	:
BaMG	PopRk	3573	FA_VintageGPop_XS	4/4	1	148		○	:
BaMG	PopRk	3574	FB_VintageGPop_XS	4/4	1	148		○	:
BaMG	PopRk	3575	FC_VintageGPop_XS	4/4	1	148		○	:
BaMG	PopRk	3576	BA_VintageGPop_XS	4/4	1	148		○	:
BaMG	PopRk	3577	EA_VintageGPop_XS	4/4	4	148		○	:
BaMG	PopRk	3578	EB_VintageGPop_XS	4/4	4	148		○	:
BaMG	PopRk	3579	MA_WestCoastPop_XS	4/4	4	100		○	:
BaMG	PopRk	3580	MB_WestCoastPop_XS	4/4	4	100		○	:
BaMG	PopRk	3581	MC_WestCoastPop_XS	4/4	4	100		○	:
BaMG	PopRk	3582	FA_WestCoastPop_XS	4/4	1	100		○	:
BaMG	PopRk	3583	FB_WestCoastPop_XS	4/4	1	100		○	:
BaMG	PopRk	3584	FC_WestCoastPop_XS	4/4	1	100		○	:
BaMG	PopRk	3585	BA_WestCoastPop_XS	4/4	1	100		○	:
BaMG	PopRk	3586	EA_WestCoastPop_XS	4/4	4	100		○	:
BaMG	PopRk	3587	EB_WestCoastPop_XS	4/4	4	100		○	:
BaMG	PopRk	3588	MA_Brit Pop_XS	4/4	2	86		○	:
BaMG	PopRk	3589	MB_Brit Pop_XS	4/4	2	86		○	:
BaMG	PopRk	3590	MC_Brit Pop_XS	4/4	2	86		○	:
BaMG	PopRk	3591	FA_Brit Pop_XS	4/4	1	86		○	:
BaMG	PopRk	3592	FB_Brit Pop_XS	4/4	1	86		○	:
BaMG	PopRk	3593	FC_Brit Pop_XS	4/4	1	86		○	:
BaMG	PopRk	3594	BA_Brit Pop_XS	4/4	1	86		○	:
BaMG	PopRk	3595	EA_Brit Pop_XS	4/4	4	86		○	:
BaMG	PopRk	3596	EB_Brit Pop_XS	4/4	4	86		○	:
BaMG	PopRk	3597	MA_BritPopSwing_XS	4/4	2	110		○	:
BaMG	PopRk	3598	MB_BritPopSwing_XS	4/4	2	110		○	:
BaMG	PopRk	3599	MC_BritPopSwing_XS	4/4	2	110		○	:
BaMG	PopRk	3600	FA_BritPopSwing_XS	4/4	1	110		○	:
BaMG	PopRk	3601	FB_BritPopSwing_XS	4/4	1	110		○	:
BaMG	PopRk	3602	FC_BritPopSwing_XS	4/4	1	110		○	:
BaMG	PopRk	3603	BA_BritPopSwing_XS	4/4	1	110		○	:
BaMG	PopRk	3604	EA_BritPopSwing_XS	4/4	4	110		○	:
BaMG	PopRk	3605	EB_BritPopSwing_XS	4/4	4	110		○	:
BaMG	PopRk	3606	MA_Cool 8Beat_XS	4/4	2	100		○	:
BaMG	PopRk	3607	MB_Cool 8Beat_XS	4/4	2	100		○	:
BaMG	PopRk	3608	MC_Cool 8Beat_XS	4/4	2	100		○	:
BaMG	PopRk	3609	FA_Cool 8Beat_XS	4/4	1	100		○	:
BaMG	PopRk	3610	FB_Cool 8Beat_XS	4/4	1	100		○	:
BaMG	PopRk	3611	FC_Cool 8Beat_XS	4/4	1	100		○	:
BaMG	PopRk	3612	BA_Cool 8Beat_XS	4/4	1	100		○	:
BaMG	PopRk	3613	EA_Cool 8Beat_XS	4/4	4	100		○	:
BaMG	PopRk	3614	EB_Cool 8Beat_XS	4/4	4	100		○	:
BaMG	PopRk	3615	MA_BritRockPop_XS	4/4	4	123		○	:
BaMG	PopRk	3616	MB_BritRockPop_XS	4/4	4	123		○	:
BaMG	PopRk	3617	MC_BritRockPop_XS	4/4	4	123		○	:
BaMG	PopRk	3618	FA_BritRockPop_XS	4/4	1	123		○	:
BaMG	PopRk	3619	FB_BritRockPop_XS	4/4	1	123		○	:
BaMG	PopRk	3620	FC_BritRockPop_XS	4/4	1	123		○	:
BaMG	PopRk	3621	BA_BritRockPop_XS	4/4	1	123		○	:
BaMG	PopRk	3622	EA_BritRockPop_XS	4/4	6	123		○	:
BaMG	PopRk	3623	MA_80'sPopRock_XS	4/4	4	111		○	*Mega Pick Open Mute
BaMG	PopRk	3624	MB_80'sPopRock_XS	4/4	4	111		○	:
BaMG	PopRk	3625	MC_80'sPopRock_XS	4/4	4	111		○	:
BaMG	PopRk	3626	FA_80'sPopRock_XS	4/4	1	111		○	:
BaMG	PopRk	3627	FB_80'sPopRock_XS	4/4	1	111		○	:
BaMG	PopRk	3628	FC_80'sPopRock_XS	4/4	1	111		○	:
BaMG	PopRk	3629	BA_80'sPopRock_XS	4/4	1	111		○	:
BaMG	PopRk	3630	EA_80'sPopRock_XS	4/4	7	111		○	:
BaMG	PopRk	3631	MA_80'sSynthRock_XS	4/4	4	96		○	*Mega Finger+Harmonic
BaMG	PopRk	3632	MB_80'sSynthRock_XS	4/4	4	96		○	:
BaMG	PopRk	3633	MC_80'sSynthRock_XS	4/4	8	96		○	:
BaMG	PopRk	3634	FA_80'sSynthRock_XS	4/4	1	96		○	:
BaMG	PopRk	3635	FB_80'sSynthRock_XS	4/4	1	96		○	:
BaMG	PopRk	3636	FC_80'sSynthRock_XS	4/4	1	96		○	:
BaMG	PopRk	3637	BA_80'sSynthRock_XS	4/4					

Arpeggio Type List

Main Category	Sub Category	ARP No.	ARP Name	Time Signature	Length	Original Tempo	Accent	Random SFX	Voice Type
BaMG	PopRk	3647	MA_60sChartSwing_XS	4/4	4	123		○	"Mega Finger+Harmonic"
BaMG	PopRk	3648	MB_60sChartSwing_XS	4/4	4	123		○	:
BaMG	PopRk	3649	MC_60sChartSwing_XS	4/4	4	123		○	:
BaMG	PopRk	3650	FA_60sChartSwing_XS	4/4	1	123		○	:
BaMG	PopRk	3651	FB_60sChartSwing_XS	4/4	1	123		○	:
BaMG	PopRk	3652	FC_60sChartSwing_XS	4/4	1	123		○	:
BaMG	PopRk	3653	BA_60sChartSwing_XS	4/4	1	123		○	:
BaMG	PopRk	3654	EA_60sChartSwing_XS	4/4	4	123		○	:
BaMG	PopRk	3655	MA_16Beat Pop 1_XS	4/4	4	103		○	"Mega Slap Bass"
BaMG	PopRk	3656	MB_16Beat Pop 1_XS	4/4	4	103		○	:
BaMG	PopRk	3657	MC_16Beat Pop 1_XS	4/4	4	103		○	:
BaMG	PopRk	3658	FA_16Beat Pop 1_XS	4/4	1	103		○	:
BaMG	PopRk	3659	FB_16Beat Pop 1_XS	4/4	1	103		○	:
BaMG	PopRk	3660	FC_16Beat Pop 1_XS	4/4	1	103		○	:
BaMG	PopRk	3661	BA_16Beat Pop 1_XS	4/4	1	103		○	:
BaMG	PopRk	3662	MA_16Beat Pop 1_ES	4/4	4	103		○	:
BaMG	PopRk	3663	MB_16Beat Pop 1_ES	4/4	4	103		○	:
BaMG	PopRk	3664	MC_16Beat Pop 1_ES	4/4	4	103		○	:
BaMG	PopRk	3665	FA_16Beat Pop 1_ES	4/4	1	103		○	:
BaMG	PopRk	3666	FB_16Beat Pop 1_ES	4/4	1	103		○	:
BaMG	PopRk	3667	FC_16Beat Pop 1_ES	4/4	1	103		○	:
BaMG	PopRk	3668	BA_16Beat Pop 1_ES	4/4	1	103		○	:
BaMG	Balad	3669	MA_GuitarBallad_XS	4/4	8	94		○	"Mega Finger+Slap"
BaMG	Balad	3670	MB_GuitarBallad_XS	4/4	8	94		○	:
BaMG	Balad	3671	MC_GuitarBallad_XS	4/4	8	94		○	:
BaMG	Balad	3672	FA_GuitarBallad_XS	4/4	1	94		○	:
BaMG	Balad	3673	FB_GuitarBallad_XS	4/4	1	94		○	:
BaMG	Balad	3674	FC_GuitarBallad_XS	4/4	1	94		○	:
BaMG	Balad	3675	BA_GuitarBallad_XS	4/4	1	94		○	:
BaMG	Balad	3676	EA_GuitarBallad_XS	4/4	4	94		○	:
BaMG	Balad	3677	EB_GuitarBallad_XS	4/4	4	94		○	:
BaMG	Balad	3678	MA_Unplugged 1_XS	4/4	4	120		○	"Mega Acoustic Bass"
BaMG	Balad	3679	MB_Unplugged 1_XS	4/4	4	120		○	:
BaMG	Balad	3680	MC_Unplugged 1_XS	4/4	4	120		○	:
BaMG	Balad	3681	FA_Unplugged 1_XS	4/4	1	120		○	:
BaMG	Balad	3682	FB_Unplugged 1_XS	4/4	1	120		○	:
BaMG	Balad	3683	FC_Unplugged 1_XS	4/4	1	120		○	:
BaMG	Balad	3684	BA_Unplugged 1_XS	4/4	1	120		○	:
BaMG	Balad	3685	MA_Unplugged 2_XS	4/4	8	120		○	"Mega Finger+Slap"
BaMG	Balad	3686	MB_Unplugged 2_XS	4/4	8	120		○	:
BaMG	Balad	3687	MC_Unplugged 2_XS	4/4	8	120		○	:
BaMG	Balad	3688	FA_Unplugged 2_XS	4/4	1	120		○	:
BaMG	Balad	3689	FB_Unplugged 2_XS	4/4	1	120		○	:
BaMG	Balad	3690	FC_Unplugged 2_XS	4/4	1	120		○	:
BaMG	Balad	3691	BA_Unplugged 2_XS	4/4	1	120		○	:
BaMG	Balad	3692	EA_Unplugged 2_XS	4/4	5	120		○	:
BaMG	Balad	3693	EB_Unplugged 2_XS	4/4	4	120		○	:
BaMG	Balad	3694	MA_8Beat Ballad_XS	4/4	4	101		○	:
BaMG	Balad	3695	MB_8Beat Ballad_XS	4/4	4	101		○	:
BaMG	Balad	3696	MC_8Beat Ballad_XS	4/4	4	101		○	:
BaMG	Balad	3697	FA_8Beat Ballad_XS	4/4	1	101		○	:
BaMG	Balad	3698	FB_8Beat Ballad_XS	4/4	1	101		○	:
BaMG	Balad	3699	FC_8Beat Ballad_XS	4/4	1	101		○	:
BaMG	Balad	3700	BA_8Beat Ballad_XS	4/4	1	101		○	:
BaMG	Balad	3701	EA_8Beat Ballad_XS	4/4	5	101		○	:
BaMG	Balad	3702	EB_8Beat Ballad_XS	4/4	5	101		○	:
BaMG	Balad	3703	MA_EP Ballad_XS	4/4	2	60		○	:
BaMG	Balad	3704	MB_EP Ballad_XS	4/4	2	60		○	:
BaMG	Balad	3705	MC_EP Ballad_XS	4/4	2	60		○	:
BaMG	Balad	3706	FA_EP Ballad_XS	4/4	1	60		○	:
BaMG	Balad	3707	FB_EP Ballad_XS	4/4	1	60		○	:
BaMG	Balad	3708	FC_EP Ballad_XS	4/4	1	60		○	:
BaMG	Balad	3709	BA_EP Ballad_XS	4/4	1	60		○	:
BaMG	Balad	3710	EA_EP Ballad_XS	4/4	4	60		○	:
BaMG	Balad	3711	EB_EP Ballad_XS	4/4	4	60		○	:
BaMG	Balad	3712	EA_Nu Jazz Bass_XS	4/4	4	61		○	:
BaMG	R&B-M	3713	MA_Slow & Easy_XS	4/4	4	72		○	:
BaMG	R&B-M	3714	MB_Slow & Easy_XS	4/4	4	72		○	:
BaMG	R&B-M	3715	MC_Slow & Easy_XS	4/4	4	72		○	:
BaMG	R&B-M	3716	FA_Slow & Easy_XS	4/4	1	72		○	:
BaMG	R&B-M	3717	FB_Slow & Easy_XS	4/4	1	72		○	:
BaMG	R&B-M	3718	FC_Slow & Easy_XS	4/4	1	72		○	:
BaMG	R&B-M	3719	BA_Slow & Easy_XS	4/4	1	72		○	:
BaMG	R&B-M	3720	EA_Slow & Easy_XS	4/4	3	72		○	:
BaMG	R&B-M	3721	EB_Slow & Easy_XS	4/4	4	72		○	:
BaMG	R&B-C	3722	MA_StandrdDisco_XS	4/4	4	120		○	:
BaMG	R&B-C	3723	MB_StandrdDisco_XS	4/4	4	120		○	:
BaMG	R&B-C	3724	MC_StandrdDisco_XS	4/4	4	120		○	:
BaMG	R&B-C	3725	FA_StandrdDisco_XS	4/4	1	120		○	:
BaMG	R&B-C	3726	FB_StandrdDisco_XS	4/4	1	120		○	:
BaMG	R&B-C	3727	FC_StandrdDisco_XS	4/4	1	120		○	:
BaMG	R&B-C	3728	BA_StandrdDisco_XS	4/4	1	120		○	:
BaMG	R&B-C	3729	EA_StandrdDisco_XS	4/4	3	120		○	:

Main Category	Sub Category	ARP No.	ARP Name	Time Signature	Length	Original Tempo	Accent	Random SFX	Voice Type
BaMG	R&B-C	3730	EB_StandrdDisco_XS	4/4	3	120		○	"Mega Finger+Slap"
BaMG	R&B-C	3731	MA_Retro Disco_XS	4/4	4	108		○	:
BaMG	R&B-C	3732	MB_Retro Disco_XS	4/4	4	108		○	:
BaMG	R&B-C	3733	MC_Retro Disco_XS	4/4	4	108		○	:
BaMG	R&B-C	3734	FA_Retro Disco_XS	4/4	1	108		○	:
BaMG	R&B-C	3735	FB_Retro Disco_XS	4/4	1	108		○	:
BaMG	R&B-C	3736	FC_Retro Disco_XS	4/4	1	108		○	:
BaMG	R&B-C	3737	BA_Retro Disco_XS	4/4	1	108		○	:
BaMG	R&B-C	3738	EA_Retro Disco_XS	4/4	4	108		○	:
BaMG	R&B-C	3739	EB_Retro Disco_XS	4/4	4	108		○	:
BaMG	R&B-C	3740	MA_70sCoolDisco_XS	4/4	4	114		○	:
BaMG	R&B-C	3741	MB_70sCoolDisco_XS	4/4	4	114		○	:
BaMG	R&B-C	3742	MC_70sCoolDisco_XS	4/4	4	114		○	:
BaMG	R&B-C	3743	FA_70sCoolDisco_XS	4/4	1	114		○	:
BaMG	R&B-C	3744	FB_70sCoolDisco_XS	4/4	1	114		○	:
BaMG	R&B-C	3745	FC_70sCoolDisco_XS	4/4	1	114		○	:
BaMG	R&B-C	3746	BA_70sCoolDisco_XS	4/4	1	114		○	:
BaMG	R&B-C	3747	EA_70sCoolDisco_XS	4/4	4	114		○	:
BaMG	R&B-C	3748	EB_70sCoolDisco_XS	4/4	3	114		○	:
BaMG	R&B-C	3749	MA_Philadelphia_XS	4/4	2	100		○	:
BaMG	R&B-C	3750	MB_Philadelphia_XS	4/4	2	100		○	:
BaMG	R&B-C	3751	MC_Philadelphia_XS	4/4	2	100		○	:
BaMG	R&B-C	3752	FA_Philadelphia_XS	4/4	1	100		○	:
BaMG	R&B-C	3753	FB_Philadelphia_XS	4/4	1	100		○	:
BaMG	R&B-C	3754	FC_Philadelphia_XS	4/4	1	100		○	:
BaMG	R&B-C	3755	BA_Philadelphia_XS	4/4	1	100		○	:
BaMG	R&B-C	3756	EA_Philadelphia_XS	4/4	4	100		○	:
BaMG	R&B-C	3757	EB_Philadelphia_XS	4/4	3	100		○	:
BaMG	R&B-C	3758	MA_Soul 1_XS	4/4	2	116		○	:
BaMG	R&B-C	3759	MB_Soul 1_XS	4/4	2	116		○	:
BaMG	R&B-C	3760	MC_Soul 1_XS	4/4	2	116		○	:
BaMG	R&B-C	3761	FA_Soul 1_XS	4/4	1	116		○	:
BaMG	R&B-C	3762	FB_Soul 1_XS	4/4	1	116		○	:
BaMG	R&B-C	3763	FC_Soul 1_XS	4/4	1	116		○	:
BaMG	R&B-C	3764	BA_Soul 1_XS	4/4	1	116		○	:
BaMG	R&B-C	3765	EA_Soul 1_XS	4/4	4	116		○	:
BaMG	R&B-C	3766	EB_Soul 1_XS	4/4	3	116		○	:
BaMG	R&B-C	3767	MA_70sChartSoul_XS	4/4	2	108		○	:
BaMG	R&B-C	3768	MB_70sChartSoul_XS	4/4	2	108		○	:
BaMG	R&B-C	3769	MC_70sChartSoul_XS	4/4	2	108		○	:
BaMG	R&B-C	3770	FA_70sChartSoul_XS	4/4	1	108		○	:
BaMG	R&B-C	3771	FB_70sChartSoul_XS	4/4	1	108		○	:
BaMG	R&B-C	3772	FC_70sChartSoul_XS	4/4	1	108		○	:
BaMG	R&B-C	3773	BA_70sChartSoul_XS	4/4	1	108		○	:
BaMG	R&B-C	3774	EA_70sChartSoul_XS	4/4	5	108		○	:
BaMG	R&B-C	3775	EB_70sChartSoul_XS	4/4	3	108		○	:
BaMG	R&B-C	3776	MA_Frankly Soul_XS	4/4	4	120		○	:
BaMG	R&B-C	3777	MB_Frankly Soul_XS	4/4	4	120		○	:
BaMG	R&B-C	3778	MC_Frankly Soul_XS	4/4	4	120		○	:
BaMG	R&B-C	3779	FA_Frankly Soul_XS	4/4	1	120		○	:
BaMG	R&B-C	3780	FB_Frankly Soul_XS	4/4	1	120		○	:
BaMG	R&B-C	3781	FC_Frankly Soul_XS	4/4	1	120		○	:
BaMG	R&B-C	3782	BA_Frankly Soul_XS	4/4	1	120		○	:
BaMG	R&B-C	3783	EA_Frankly Soul_XS	4/4	3	120		○	:
BaMG	R&B-C	3784	EB_Frankly Soul_XS	4/4	4	120		○	:
BaMG	R&B-C	3785	MA_Soul Band_XS	4/4	4	129		○	:
BaMG	R&B-C	3786	MB_Soul Band_XS	4/4	4	129		○	:
BaMG	R&B-C	3787	MC_Soul Band_XS	4/4	4	129		○	:
BaMG	R&B-C	3788	FA_Soul Band_XS	4/4	1	129		○	:
BaMG	R&B-C	3789	FB_Soul Band_XS	4/4	1	129		○	:
BaMG	R&B-C	3790	FC_Soul Band_XS	4/4	1	129		○	:
BaMG	R&B-C	3791	BA_Soul Band_XS	4/4	1	129		○	:
BaMG	R&B-C	3792	EA_Soul Shuffle_XS	4/4	4	98		○	:
BaMG	R&B-C	3793	EB_Soul Shuffle_XS	4/4	4	98		○	:
BaMG	R&B-C	3794	MC_Soul Shuffle_XS	4/4	4	98		○	:
BaMG	R&B-C	3795	FA_Soul Shuffle_XS	4/4	1	98		○	:
BaMG	R&B-C	3796	FB_Soul Shuffle_XS	4/4	1	98		○	:
BaMG	R&B-C	3797	FC_Soul Shuffle_XS	4/4	1	98		○	:
BaMG	R&B-C	3798	BA_Soul Shuffle_XS	4/4	1	98		○	:
BaMG	R&B-C	3799	EA_Soul Shuffle_XS	4/4	3	98		○	:
BaMG	R&B-C	3800	EB_Soul Shuffle_XS	4/4	3	98		○	:
BaMG	R&B-C	3801	MA_Soul Swing_XS	4/4					

Arpeggio Type List

Main Category	Sub Category	ARP No.	ARP Name	Time Signature	Length	Original Tempo	Accent	Random SFX	Voice Type
BaMG	R&B-C	3813	FA_GospelBrothr_XS	4/4	1	108		○	*Mega Finger+Slap
BaMG	R&B-C	3814	FB_GospelBrothr_XS	4/4	1	108		○	:
BaMG	R&B-C	3815	FC_GospelBrothr_XS	4/4	1	108		○	:
BaMG	R&B-C	3816	BA_GospelBrothr_XS	4/4	1	108		○	:
BaMG	R&B-C	3817	EA_GospelBrothr_XS	4/4	4	108		○	:
BaMG	R&B-C	3818	EB_GospelBrothr_XS	4/4	3	108		○	:
BaMG	Funk	3819	MA_Funk 1_XS	4/4	8	104		○	:
BaMG	Funk	3820	MB_Funk 1_XS	4/4	8	104		○	:
BaMG	Funk	3821	MC_Funk 1_XS	4/4	8	104		○	:
BaMG	Funk	3822	FA_Funk 1_XS	4/4	1	104		○	:
BaMG	Funk	3823	FB_Funk 1_XS	4/4	1	104		○	:
BaMG	Funk	3824	FC_Funk 1_XS	4/4	1	104		○	:
BaMG	Funk	3825	BA_Funk 1_XS	4/4	1	104		○	:
BaMG	Funk	3826	EA_Funk 1_XS	4/4	9	104		○	:
BaMG	Funk	3827	EB_Funk 1_XS	4/4	4	104		○	:
BaMG	Funk	3828	MA_Funk PopRock_XS	4/4	4	95		○	:
BaMG	Funk	3829	MB_Funk PopRock_XS	4/4	4	95		○	:
BaMG	Funk	3830	MC_Funk PopRock_XS	4/4	4	95		○	:
BaMG	Funk	3831	FA_Funk PopRock_XS	4/4	1	95		○	:
BaMG	Funk	3832	FB_Funk PopRock_XS	4/4	1	95		○	:
BaMG	Funk	3833	FC_Funk PopRock_XS	4/4	1	95		○	:
BaMG	Funk	3834	BA_Funk PopRock_XS	4/4	1	95		○	:
BaMG	Funk	3835	EA_Funk PopRock_XS	4/4	4	94		○	:
BaMG	Funk	3836	EB_Funk PopRock_XS	4/4	3	94		○	:
BaMG	Funk	3837	MA_Jazz Funk 1_XS	4/4	4	120		○	:
BaMG	Funk	3838	MB_Jazz Funk 1_XS	4/4	4	120		○	:
BaMG	Funk	3839	MC_Jazz Funk 1_XS	4/4	4	120		○	:
BaMG	Funk	3840	FA_Jazz Funk 1_XS	4/4	1	120		○	:
BaMG	Funk	3841	FB_Jazz Funk 1_XS	4/4	1	120		○	:
BaMG	Funk	3842	FC_Jazz Funk 1_XS	4/4	1	120		○	:
BaMG	Funk	3843	BA_Jazz Funk 1_XS	4/4	1	120		○	:
BaMG	Funk	3844	EA_Jazz Funk 1_XS	4/4	3	120		○	:
BaMG	Funk	3845	EB_Jazz Funk 1_XS	4/4	3	120		○	:
BaMG	Funk	3846	MA_Jazz Pop_XS	4/4	2	102		○	:
BaMG	Funk	3847	MB_Jazz Pop_XS	4/4	2	102		○	:
BaMG	Funk	3848	MC_Jazz Pop_XS	4/4	2	102		○	:
BaMG	Funk	3849	FA_Jazz Pop_XS	4/4	1	102		○	:
BaMG	Funk	3850	FB_Jazz Pop_XS	4/4	1	102		○	:
BaMG	Funk	3851	FC_Jazz Pop_XS	4/4	1	102		○	:
BaMG	Funk	3852	BA_Jazz Pop_XS	4/4	1	102		○	:
BaMG	Funk	3853	MA_Gospel Funk_XS	4/4	4	106		○	:
BaMG	Funk	3854	MB_Gospel Funk_XS	4/4	4	106		○	:
BaMG	Funk	3855	MC_Gospel Funk_XS	4/4	4	106		○	:
BaMG	Funk	3856	FA_Gospel Funk_XS	4/4	1	106		○	:
BaMG	Funk	3857	FB_Gospel Funk_XS	4/4	1	106		○	:
BaMG	Funk	3858	FC_Gospel Funk_XS	4/4	1	106		○	:
BaMG	Funk	3859	BA_Gospel Funk_XS	4/4	1	106		○	:
BaMG	Funk	3860	EA_Gospel Funk_XS	4/4	4	106		○	:
BaMG	Funk	3861	EB_Gospel Funk_XS	4/4	3	106		○	:
BaMG	Funk	3862	MA_Funk Disco_XS	4/4	2	126		○	:
BaMG	Funk	3863	MB_Funk Disco_XS	4/4	2	126		○	:
BaMG	Funk	3864	MC_Funk Disco_XS	4/4	2	126		○	:
BaMG	Funk	3865	FA_Funk Disco_XS	4/4	1	126		○	:
BaMG	Funk	3866	FB_Funk Disco_XS	4/4	1	126		○	:
BaMG	Funk	3867	FC_Funk Disco_XS	4/4	1	126		○	:
BaMG	Funk	3868	BA_Funk Disco_XS	4/4	1	126		○	:
BaMG	Funk	3869	EA_Funk Disco_XS	4/4	4	126		○	:
BaMG	Funk	3870	EB_Funk Disco_XS	4/4	3	126		○	:
BaMG	Funk	3871	MA_70sDiscoFunk_XS	4/4	4	112		○	:
BaMG	Funk	3872	MB_70sDiscoFunk_XS	4/4	4	112		○	:
BaMG	Funk	3873	MC_70sDiscoFunk_XS	4/4	4	112		○	:
BaMG	Funk	3874	FA_70sDiscoFunk_XS	4/4	1	112		○	:
BaMG	Funk	3875	FB_70sDiscoFunk_XS	4/4	1	112		○	:
BaMG	Funk	3876	FC_70sDiscoFunk_XS	4/4	1	112		○	:
BaMG	Funk	3877	BA_70sDiscoFunk_XS	4/4	1	112		○	:
BaMG	Funk	3878	EA_70sDiscoFunk_XS	4/4	4	112		○	:
BaMG	Funk	3879	EB_70sDiscoFunk_XS	4/4	3	112		○	:
BaMG	Funk	3880	EA_OakCustomBass_XS	4/4	4	114		○	:
BaMG	Jazz	3881	MA_Modern Jazz_XS	4/4	16	218		○	*Mega Acoustic Bass
BaMG	Jazz	3882	MB_Modern Jazz_XS	4/4	16	218		○	:
BaMG	Jazz	3883	MC_Modern Jazz_XS	4/4	16	218		○	:
BaMG	Jazz	3884	FA_Modern Jazz_XS	4/4	1	218		○	:
BaMG	Jazz	3885	FB_Modern Jazz_XS	4/4	1	218		○	:
BaMG	Jazz	3886	FC_Modern Jazz_XS	4/4	1	218		○	:
BaMG	Jazz	3887	BA_Modern Jazz_XS	4/4	1	218		○	:
BaMG	Jazz	3888	EA_Modern Jazz_XS	4/4	6	218		○	:
BaMG	Jazz	3889	EB_Modern Jazz_XS	4/4	7	218		○	:
BaMG	Jazz	3890	MA_JazzGtrClub_XS	4/4	8	142		○	:
BaMG	Jazz	3891	MB_JazzGtrClub_XS	4/4	8	142		○	:
BaMG	Jazz	3892	MC_JazzGtrClub_XS	4/4	8	142		○	:
BaMG	Jazz	3893	FA_JazzGtrClub_XS	4/4	1	142		○	:
BaMG	Jazz	3894	FB_JazzGtrClub_XS	4/4	1	142		○	:
BaMG	Jazz	3895	FC_JazzGtrClub_XS	4/4	1	142		○	:

Main Category	Sub Category	ARP No.	ARP Name	Time Signature	Length	Original Tempo	Accent	Random SFX	Voice Type
BaMG	Jazz	3896	BA_JazzGtrClub_XS	4/4	1	142		○	*Mega Acoustic Bass
BaMG	Jazz	3897	EA_JazzGtrClub_XS	4/4	6	142		○	:
BaMG	Jazz	3898	MA_JazzWaltzMed_XS	3/4	8	180		○	:
BaMG	Jazz	3899	MB_JazzWaltzMed_XS	3/4	8	180		○	:
BaMG	Jazz	3900	MC_JazzWaltzMed_XS	3/4	8	180		○	:
BaMG	Jazz	3901	FA_JazzWaltzMed_XS	3/4	1	180		○	:
BaMG	Jazz	3902	FB_JazzWaltzMed_XS	3/4	1	180		○	:
BaMG	Jazz	3903	FC_JazzWaltzMed_XS	3/4	1	180		○	:
BaMG	Jazz	3904	BA_JazzWaltzMed_XS	3/4	1	180		○	:
BaMG	Jazz	3905	EA_JazzWaltzMed_XS	3/4	7	180		○	:
BaMG	Jazz	3906	MA_R&R Shuffle_XS	4/4	4	192		○	:
BaMG	Jazz	3907	MB_R&R Shuffle_XS	4/4	4	192		○	:
BaMG	Jazz	3908	MC_R&R Shuffle_XS	4/4	4	192		○	:
BaMG	Jazz	3909	FA_R&R Shuffle_XS	4/4	1	192		○	:
BaMG	Jazz	3910	FB_R&R Shuffle_XS	4/4	1	192		○	:
BaMG	Jazz	3911	FC_R&R Shuffle_XS	4/4	1	192		○	:
BaMG	Jazz	3912	BA_R&R Shuffle_XS	4/4	1	192		○	:
BaMG	Jazz	3913	EA_R&R Shuffle_XS	4/4	5	192		○	:
BaMG	Jazz	3914	EB_R&R Shuffle_XS	4/4	5	192		○	:
BaMG	Jazz	3915	MA_ShuffleBlues_XS	4/4	4	115		○	*Mega Pick Open Mute
BaMG	Jazz	3916	MB_ShuffleBlues_XS	4/4	4	115		○	:
BaMG	Jazz	3917	MC_ShuffleBlues_XS	4/4	4	115		○	:
BaMG	Jazz	3918	FA_ShuffleBlues_XS	4/4	1	115		○	:
BaMG	Jazz	3919	FB_ShuffleBlues_XS	4/4	1	115		○	:
BaMG	Jazz	3920	FC_ShuffleBlues_XS	4/4	1	115		○	:
BaMG	Jazz	3921	BA_ShuffleBlues_XS	4/4	1	115		○	:
BaMG	Jazz	3922	EA_ShuffleBlues_XS	4/4	5	115		○	:
BaMG	Jazz	3923	EB_ShuffleBlues_XS	4/4	6	115		○	:
BaMG	Jazz	3924	MA_Slow Blues 1_XS	4/4	2	49		○	*Mega Finger+Slap
BaMG	Jazz	3925	MB_Slow Blues 1_XS	4/4	2	49		○	:
BaMG	Jazz	3926	MC_Slow Blues 1_XS	4/4	2	49		○	:
BaMG	Jazz	3927	FA_Slow Blues 1_XS	4/4	1	49		○	:
BaMG	Jazz	3928	FB_Slow Blues 1_XS	4/4	1	49		○	:
BaMG	Jazz	3929	FC_Slow Blues 1_XS	4/4	1	49		○	:
BaMG	Jazz	3930	BA_Slow Blues 1_XS	4/4	1	49		○	:
BaMG	Jazz	3931	EA_Slow Blues 1_XS	4/4	3	49		○	:
BaMG	Jazz	3932	EB_Slow Blues 1_XS	4/4	3	49		○	:
BaMG	Jazz	3933	MA_Piano Boogie_XS	4/4	8	160		○	*Mega Acoustic Bass
BaMG	Jazz	3934	MB_Piano Boogie_XS	4/4	4	160		○	:
BaMG	Jazz	3935	MC_Piano Boogie_XS	4/4	4	160		○	:
BaMG	Jazz	3936	FA_Piano Boogie_XS	4/4	1	160		○	:
BaMG	Jazz	3937	FB_Piano Boogie_XS	4/4	1	160		○	:
BaMG	Jazz	3938	FC_Piano Boogie_XS	4/4	1	160		○	:
BaMG	Jazz	3939	BA_Piano Boogie_XS	4/4	1	160		○	:
BaMG	Jazz	3940	EA_Piano Boogie_XS	4/4	5	160		○	:
BaMG	Jazz	3941	EB_Piano Boogie_XS	4/4	5	160		○	:
BaMG	Latin	3942	MA_Salsa 1_XS	4/4	4	177		○	:
BaMG	Latin	3943	MB_Salsa 1_XS	4/4	4	177		○	:
BaMG	Latin	3944	MC_Salsa 1_XS	4/4	4	177		○	:
BaMG	Latin	3945	FA_Salsa 1_XS	4/4	1	177		○	:
BaMG	Latin	3946	FB_Salsa 1_XS	4/4	1	177		○	:
BaMG	Latin	3947	FC_Salsa 1_XS	4/4	1	177		○	:
BaMG	Latin	3948	BA_Salsa 1_XS	4/4	1	177		○	:
BaMG	Latin	3949	EA_Salsa 1_XS	4/4	5	177		○	:
BaMG	Latin	3950	EB_Salsa 1_XS	4/4	5	177		○	:
BaMG	Latin	3951	MA_AtroCuban_XS	4/4	4	200		○	:
BaMG	Latin	3952	MB_AtroCuban_XS	4/4	4	200		○	:
BaMG	Latin	3953	MC_AtroCuban_XS	4/4	4	200		○	:
BaMG	Latin	3954	FA_AtroCuban_XS	4/4	1	200		○	:
BaMG	Latin	3955	FB_AtroCuban_XS	4/4	1	200		○	:
BaMG	Latin	3956	FC_AtroCuban_XS	4/4	1	200		○	:
BaMG	Latin	3957	BA_AtroCuban_XS	4/4	1	200		○	:
BaMG	Latin	3958	EA_AtroCuban_XS	4/4	6	200		○	:
BaMG	Latin	3959	EB_AtroCuban_XS	4/4	5	200		○	:
BaMG	Latin	3960	MA_Brazil Samba_XS	4/4	4	96		○	*Mega Finger+Slap
BaMG	Latin	3961	MB_Brazil Samba_XS	4/4	4	96		○	:
BaMG	Latin	3962	MC_Brazil Samba_XS	4/4	4	96		○	:
BaMG	Latin	3963	FA_Brazil Samba_XS	4/4	1	96		○	:
BaMG	Latin	3964	FB_Brazil Samba_XS	4/4	1	96		○	:
BaMG	Latin	3965	FC_Brazil Samba_XS	4/4	1	96		○	:
BaMG	Latin	3966	BA_Brazil Samba_XS	4/4	1	96		○	:
BaMG	Latin	3967	EA_Brazil Samba_XS	4/4	4	96		○	:
BaMG	Latin	3968	EB_Brazil Samba_XS	4/4	4	96		○	:
BaMG	Latin	3969	MA_Bomba_XS	4/4	4	99		○	*Mega Acoustic Bass
BaMG	Latin	3970	MB_Bomba_XS	4/4	4	99		○	:
BaMG	Latin	3971	MC_Bomba_XS	4/4	4	99		○	:
BaMG	Latin	3972	FA_Bomba_XS	4/4	1	99		○	

Arpeggio Type List

Main Category	Sub Category	ARP No.	ARP Name	Time Signature	Length	Original Tempo	Accent	Random SFX	Voice Type
BaMG	Latin	3979	MB_Bossa_XS	4/4	4	124		○	*Mega Finger+Slap
BaMG	Latin	3980	MC_Bossa_XS	4/4	4	124		○	:
BaMG	Latin	3981	FA_Bossa_XS	4/4	1	124		○	:
BaMG	Latin	3982	FB_Bossa_XS	4/4	1	124		○	:
BaMG	Latin	3983	FC_Bossa_XS	4/4	1	124		○	:
BaMG	Latin	3984	BA_Bossa_XS	4/4	1	124		○	:
BaMG	Latin	3985	EA_Bossa_XS	4/4	4	123		○	:
BaMG	Latin	3986	EB_Bossa_XS	4/4	4	123		○	:
BaMG	Latin	3987	MA_Merengue_XS	4/4	4	130		○	:
BaMG	Latin	3988	MB_Merengue_XS	4/4	4	130		○	:
BaMG	Latin	3989	MC_Merengue_XS	4/4	4	130		○	:
BaMG	Latin	3990	FA_Merengue_XS	4/4	1	130		○	:
BaMG	Latin	3991	FB_Merengue_XS	4/4	1	130		○	:
BaMG	Latin	3992	FC_Merengue_XS	4/4	1	130		○	:
BaMG	Latin	3993	BA_Merengue_XS	4/4	1	130		○	:
BaMG	Latin	3994	EA_Merengue_XS	4/4	3	130		○	:
BaMG	Latin	3995	EB_Merengue_XS	4/4	3	130		○	:
BaMG	Latin	3996	MA_Guaguanco_XS	4/4	4	120		○	*Mega Acoustic Bass
BaMG	Latin	3997	MB_Guaguanco_XS	4/4	4	120		○	:
BaMG	Latin	3998	MC_Guaguanco_XS	4/4	4	120		○	:
BaMG	Latin	3999	FA_Guaguanco_XS	4/4	1	120		○	:
BaMG	Latin	4000	FB_Guaguanco_XS	4/4	1	120		○	:
BaMG	Latin	4001	FC_Guaguanco_XS	4/4	1	120		○	:
BaMG	Latin	4002	BA_Guaguanco_XS	4/4	1	120		○	:
BaMG	Latin	4003	EA_Guaguanco_XS	4/4	3	120		○	:
BaMG	Latin	4004	EB_Guaguanco_XS	4/4	3	120		○	:
BaMG	World	4005	MA_ReggaeShuffle_XS	4/4	4	90		○	*Mega Finger+Slap
BaMG	World	4006	MB_ReggaeShuffle_XS	4/4	4	90		○	:
BaMG	World	4007	MC_ReggaeShuffle_XS	4/4	4	90		○	:
BaMG	World	4008	FA_ReggaeShuffle_XS	4/4	1	90		○	:
BaMG	World	4009	FB_ReggaeShuffle_XS	4/4	1	90		○	:
BaMG	World	4010	FC_ReggaeShuffle_XS	4/4	1	90		○	:
BaMG	World	4011	BA_ReggaeShuffle_XS	4/4	1	90		○	:
BaMG	World	4012	EA_ReggaeShuffle_XS	4/4	3	90		○	:
BaMG	World	4013	EB_ReggaeShuffle_XS	4/4	4	90		○	:
BaMG	World	4014	MA_RumbaFlamenc_XS	4/4	4	106		○	:
BaMG	World	4015	MB_RumbaFlamenc_XS	4/4	4	106		○	:
BaMG	World	4016	MC_RumbaFlamenc_XS	4/4	4	106		○	:
BaMG	World	4017	FA_RumbaFlamenc_XS	4/4	1	106		○	:
BaMG	World	4018	FB_RumbaFlamenc_XS	4/4	1	106		○	:
BaMG	World	4019	FC_RumbaFlamenc_XS	4/4	1	106		○	:
BaMG	World	4020	BA_RumbaFlamenc_XS	4/4	1	106		○	:
BaMG	World	4021	EA_RumbaFlamenc_XS	4/4	3	106		○	:
BaMG	World	4022	EB_RumbaFlamenc_XS	4/4	3	106		○	:
BaMG	World	4023	MA_ModBluegrass_XS	4/4	4	121		○	*Mega Finger+Harmonic
BaMG	World	4024	MB_ModBluegrass_XS	4/4	4	121		○	:
BaMG	World	4025	MC_ModBluegrass_XS	4/4	4	121		○	:
BaMG	World	4026	FA_ModBluegrass_XS	4/4	1	121		○	:
BaMG	World	4027	FB_ModBluegrass_XS	4/4	1	121		○	:
BaMG	World	4028	FC_ModBluegrass_XS	4/4	1	121		○	:
BaMG	World	4029	BA_ModBluegrass_XS	4/4	1	121		○	:
BaMG	World	4030	EA_ModBluegrass_XS	4/4	6	121		○	:
BaMG	World	4031	MA_Irish Hymn_XS	3/4	4	70		○	*Mega Finger+Slap
BaMG	World	4032	MB_Irish Hymn_XS	3/4	4	70		○	:
BaMG	World	4033	MC_Irish Hymn_XS	3/4	4	70		○	:
BaMG	World	4034	FA_Irish Hymn_XS	3/4	1	70		○	:
BaMG	World	4035	FB_Irish Hymn_XS	3/4	1	70		○	:
BaMG	World	4036	FC_Irish Hymn_XS	3/4	1	70		○	:
BaMG	World	4037	BA_Irish Hymn_XS	3/4	1	70		○	:
BaMG	World	4038	EA_Irish Hymn_XS	3/4	5	70		○	:
BaMG	World	4039	EB_Irish Hymn_XS	3/4	5	70		○	:
BaMG	World	4040	MA_Saeidy_XS	4/4	2	120		○	:
BaMG	World	4041	MB_Saeidy_XS	4/4	2	120		○	:
BaMG	World	4042	MC_Saeidy_XS	4/4	4	120		○	:
BaMG	World	4043	FA_Saeidy_XS	4/4	1	120		○	:
BaMG	World	4044	FB_Saeidy_XS	4/4	1	120		○	:
BaMG	World	4045	FC_Saeidy_XS	4/4	1	120		○	:
BaMG	World	4046	BA_Saeidy_XS	4/4	1	120		○	:
BaMG	World	4047	EA_Saeidy_XS	4/4	4	120		○	:
Strng	Balad	4048	MA_8Beat Ballad_XS	4/4	4	101			Strings
Strng	Balad	4049	MB_8Beat Ballad_XS	4/4	4	101			:
Strng	Balad	4050	MC_8Beat Ballad_XS	4/4	4	101			:
Strng	Balad	4051	FA_8Beat Ballad_XS	4/4	1	101			:
Strng	Balad	4052	FB_8Beat Ballad_XS	4/4	1	101			:
Strng	Balad	4053	FC_8Beat Ballad_XS	4/4	1	101			:
Strng	Balad	4054	BA_8Beat Ballad_XS	4/4	1	101			:
Strng	Balad	4055	EA_8Beat Ballad_XS	4/4	5	101			:
Strng	Balad	4056	EB_8Beat Ballad_XS	4/4	5	101			:
Strng	HipHp	4057	MA_DirtySynth_ES	4/4	4	85			:
Strng	HipHp	4058	MB_DirtySynth	4/4	4	85			:
Strng	HipHp	4059	MC_DirtySynth	4/4	4	85			:
Strng	HipHp	4060	MA_HipHopEpic_XS	4/4	2	85			:
Strng	HipHp	4061	MA_HipHopEpic	4/4	2	85			:

Main Category	Sub Category	ARP No.	ARP Name	Time Signature	Length	Original Tempo	Accent	Random SFX	Voice Type
Strng	HipHp	4062	MB_HipHopEpic	4/4	2	85			Strings
Strng	HipHp	4063	MC_HipHopEpic	4/4	2	85			:
Strng	HipHp	4064	MC_Hip Hop 1_ES	4/4	2	105			Pizzicato Strings
Strng	HipHp	4065	MD_Hip Hop 1_ES	4/4	2	105			:
Strng	HipHp	4066	FB_Hip Hop 1_ES	4/4	1	105			:
Strng	HipHp	4067	MD_Hip Hop 3_ES	4/4	2	104			Harp
Strng	R&B-M	4068	MC_New R&B 2	4/4	1	97			:
Strng	R&B-M	4069	MD_New R&B 2	4/4	1	97			:
Strng	R&B-M	4070	MA_New R&B 3_ES	4/4	2	90			Strings
Strng	R&B-M	4071	MB_New R&B 3_ES	4/4	2	90			:
Strng	R&B-M	4072	MC_New R&B 3_ES	4/4	2	90			:
Strng	R&B-M	4073	MD_New R&B 3/1_ES	4/4	2	90			:
Strng	R&B-M	4074	MD_New R&B 3/2_ES	4/4	2	90			:
Strng	R&B-M	4075	FA_New R&B 3_ES	4/4	1	90			:
Strng	R&B-M	4076	FC_New R&B 3_ES	4/4	2	90			:
Strng	R&B-M	4077	MA_Pop R&B_XS	4/4	4	67			:
Strng	R&B-M	4078	MB_Pop R&B_XS	4/4	4	67			:
Strng	R&B-M	4079	MC_Pop R&B_XS	4/4	4	67			:
Strng	R&B-M	4080	FA_Pop R&B_XS	4/4	1	67			:
Strng	R&B-M	4081	FB_Pop R&B_XS	4/4	1	67			:
Strng	R&B-M	4082	FC_Pop R&B_XS	4/4	1	67			:
Strng	R&B-M	4083	MA1_R&B Ana Pop_XS	4/4	4	95			Harp
Strng	R&B-M	4084	MB1_R&B Ana Pop_XS	4/4	4	95			:
Strng	R&B-M	4085	MC1_R&B Ana Pop_XS	4/4	4	95			:
Strng	R&B-M	4086	FA1_R&B Ana Pop_XS	4/4	1	95			:
Strng	R&B-M	4087	FB1_R&B Ana Pop_XS	4/4	1	95			:
Strng	R&B-M	4088	FC1_R&B Ana Pop_XS	4/4	1	95			:
Strng	R&B-M	4089	BA1_R&B Ana Pop_XS	4/4	1	95			:
Strng	R&B-M	4090	MA2_R&B Ana Pop_XS	4/4	4	95			Strings
Strng	R&B-M	4091	MB2_R&B Ana Pop_XS	4/4	4	95			:
Strng	R&B-M	4092	MC2_R&B Ana Pop_XS	4/4	4	95			:
Strng	R&B-M	4093	FA2_R&B Ana Pop_XS	4/4	1	95			:
Strng	R&B-M	4094	FB2_R&B Ana Pop_XS	4/4	1	95			:
Strng	R&B-M	4095	FC2_R&B Ana Pop_XS	4/4	1	95			:
Strng	R&B-M	4096	MC_Smooth 1_ES	4/4	2	115			Pizzicato Strings
Strng	R&B-M	4097	MD_Smooth 1_ES	4/4	2	115			:
Strng	R&B-M	4098	MC_Flip Hop 1_ES	4/4	2	132			:
Strng	R&B-M	4099	MD_Flip Hop 1_ES	4/4	2	132			:
Strng	R&B-M	4100	FB_Flip Hop 1_ES	4/4	1	132			:
Strng	Tekno	4101	MA_Psyche Pizz1_ES	4/4	1	143			:
Strng	Tekno	4102	MA_Psyche Pizz2_ES	4/4	1	143			:
Strng	Tekno	4103	MA_Psyche Pizz3_ES	4/4	2	143			:
Strng	Tekno	4104	MA_Psyche Pizz4_ES	4/4	3	143			:
Strng	Tekno	4105	MA_Psyche Pizz5_ES	4/4	2	143			:
Strng	World	4106	MA_Irish Hymn_XS	3/4	4	70			Strings
Strng	World	4107	MB_Irish Hymn_XS	3/4	4	70			:
Strng	World	4108	MC_Irish Hymn_XS	3/4	4	70			:
Strng	World	4109	FA_Irish Hymn_XS	3/4	1	70			:
Strng	World	4110	FB_Irish Hymn_XS	3/4	1	70			:
Strng	World	4111	FC_Irish Hymn_XS	3/4	1	70			:
Strng	World	4112	BA_Irish Hymn_XS	3/4	1	70			:
Strng	World	4113	EA_Irish Hymn_XS	3/4	5	70			:
Strng	World	4114	EB_Irish Hymn_XS	3/4	5	70			:
Strng	World	4115	MD_Turkish_ES	9/8	2	125			:
Strng	World	4116	MF_Turkish_ES	4/4	2	105			:
Strng	World	4117	IA_Turkish_ES	4/4	2	86			:
Strng	Genrl	4118	MA1_Orchestra_XS	4/4	4	102			:
Strng	Genrl	4119	MB1_Orchestra_XS	4/4	8	102			:
Strng	Genrl	4120	MC1_Orchestra_XS	4/4	8	102			:
Strng	Genrl	4121	MD1_Orchestra_XS	4/4	4	102			:
Strng	Genrl	4122	FA1_Orchestra_XS	4/4	1	102			:
Strng	Genrl	4123	MA2_Orchestra_XS	4/4	4	102			Harp
Strng	Genrl	4124	MB2_Orchestra_XS	4/4	8	102			:
Strng	Genrl	4125	MC2_Orchestra_XS	4/4	8	102			:
Strng	Genrl	4126	MD2_Orchestra_XS	4/4	4	102			:
Strng	Genrl	4127	FA2_Orchestra_XS	4/4	1	102			:
Strng	Genrl	4128	MA1_Baroque_XS	4/4	4	88			Strings
Strng	Genrl	4129	MB1_Baroque_XS	4/4	4	88			:
Strng	Genrl	4130	MC1_Baroque_XS	4/4	4	88			:
Strng	Genrl	4131	MD1_Baroque_XS	4/4	4	88			:
Strng	Genrl	4132	FA1_Baroque_XS	4/4	1	88			:
Strng	Genrl	4133	FB1_Baroque_XS	4/4	1	88			:
Strng	Genrl	4134	FC1_Baroque_XS	4/4	1	88			:
Strng	Genrl	4135	FD1_Baroque_XS	4/4	1	88			:
Strng	Genrl	4136	MA2_Baroque_XS	4/4	4	88			:
Strng	Genrl	4137	MB2_Baroque_XS	4/4	4	88			:
Strng	Genrl	4138	MC2_Baroque_XS	4/4	4	88			:
Strng	Genrl	4139	MD2_Baroque_XS	4/4	4				

Arpeggio Type List

Main Category	Sub Category	ARP No.	ARP Name	Time Signature	Length	Original Tempo	Accent	Random SFX	Voice Type
Strng	Genrl	4145	MA_Strings2	4/4	1	101			Strings
Strng	Genrl	4146	MA_Strings3	4/4	1	101			:
Strng	Genrl	4147	MA_Strings4	4/4	1	101			:
Strng	Genrl	4148	MA_Strings5	4/4	1	101			:
Strng	Genrl	4149	MA_Strings6	4/4	1	101			:
Strng	Genrl	4150	MA_Strings7	4/4	1	101			:
Strng	Genrl	4151	MA_Strings8	4/4	1	101			:
Strng	Genrl	4152	MA_Strings9*	4/4	2	120			:
Strng	Genrl	4153	MA_Jupiter	4/4	4	120			:
Strng	Genrl	4154	MA_StringsUp1_ES*	4/4	1	120			:
Strng	Genrl	4155	MA_StringsDown1_ES*	4/4	1	120			:
Strng	Genrl	4156	MA_StringsUp2_ES	4/4	1	120			:
Strng	Genrl	4157	MA_StringsDown2_ES	4/4	1	120			:
Strng	Genrl	4158	MA_Cello1*	4/4	2	120			Cello
Strng	Genrl	4159	MA_Cello2*	4/4	2	120			:
Strng	Genrl	4160	MA_OrchStrings	4/4	4	126			Strings
Strng	Genrl	4161	MA_OrchChord	4/4	4	126			:
Strng	Genrl	4162	MA_Pizz1	4/4	1	120			Pizzicato Strings
Strng	Genrl	4163	MA_Pizz2	4/4	1	120			:
Strng	Genrl	4164	MA_Pizz3	4/4	1	120			:
Strng	Genrl	4165	MA_Pizz4	4/4	1	124			:
Strng	Genrl	4166	MA_Pizz5	4/4	1	124			:
Strng	Genrl	4167	MA_Harp1	4/4	2	120			Harp
Strng	Genrl	4168	MA_Harp2	4/4	2	120			:
Strng	Genrl	4169	MA_Harp3	4/4	1	120			:
Strng	Genrl	4170	MA_Harp4	4/4	1	120			:
Brass	HipHp	4171	MA_Hip Break_XS	4/4	4	98			Brass Section
Brass	HipHp	4172	MB_Hip Break_XS	4/4	4	98			:
Brass	HipHp	4173	MC_Hip Break_XS	4/4	4	98			:
Brass	HipHp	4174	FA_Hip Break_XS	4/4	1	98			:
Brass	HipHp	4175	FB_Hip Break_XS	4/4	1	98			:
Brass	HipHp	4176	FC_Hip Break_XS	4/4	1	98			:
Brass	HipHp	4177	BA_Hip Break_XS	4/4	1	98			:
Brass	R&B-M	4178	FC_New Gospel	4/4	2	90			:
Brass	R&B-C	4179	FA_Soul 2	4/4	1	120			:
Brass	R&B-C	4180	MA_70sChartSoul_XS	4/4	2	108			"Velo Falls"
Brass	R&B-C	4181	MB_70sChartSoul_XS	4/4	2	108			:
Brass	R&B-C	4182	MC_70sChartSoul_XS	4/4	2	108			:
Brass	R&B-C	4183	FA_70sChartSoul_XS	4/4	1	108			:
Brass	R&B-C	4184	FB_70sChartSoul_XS	4/4	1	108			:
Brass	R&B-C	4185	FC_70sChartSoul_XS	4/4	1	108			:
Brass	R&B-C	4186	BA_70sChartSoul_XS	4/4	1	108			:
Brass	R&B-C	4187	EA_70sChartSoul_XS	4/4	5	108			:
Brass	R&B-C	4188	EB_70sChartSoul_XS	4/4	3	108			:
Brass	Funk	4189	MB_Funk 3	4/4	2	132			Brass Section
Brass	Funk	4190	MC_Funk 3	4/4	4	132			:
Brass	Funk	4191	MD_Funk 3	4/4	2	132			:
Brass	Funk	4192	IA_Funk 3	4/4	1	132			:
Brass	Funk	4193	FA_Funk 3	4/4	1	132			:
Brass	Funk	4194	FB_Funk 3	4/4	1	132			:
Brass	Funk	4195	MC_Jazz Funk 2	4/4	4	120			:
Brass	Funk	4196	MD_Jazz Funk 2 /1	4/4	4	120			:
Brass	Funk	4197	MD_Jazz Funk 2 /2	4/4	1	120			:
Brass	Funk	4198	IA_Jazz Funk 2	4/4	1	120			:
Brass	Funk	4199	FA_Jazz Funk 2	4/4	1	120			:
Brass	Latin	4200	MB1_Salsa 2	4/4	1	123			:
Brass	Latin	4201	MC1_Salsa 2	4/4	1	123			:
Brass	Latin	4202	FC1_Salsa 2	4/4	2	123			:
Brass	Latin	4203	MA2_Salsa 2	4/4	1	123			:
Brass	Latin	4204	MB2_Salsa 2	4/4	4	120			:
Brass	Latin	4205	MA3_Salsa 2_ES	4/4	2	123			:
Brass	Latin	4206	MB3_Salsa 2_ES	4/4	2	123			:
Brass	Latin	4207	MC3_Salsa 2_ES	4/4	2	123			:
Brass	Latin	4208	FA3_Salsa 2_ES	4/4	1	123			:
Brass	Latin	4209	FC3_Salsa 2_ES	4/4	1	123			:
Brass	Latin	4210	MD1_Samba	4/4	4	120			:
Brass	Latin	4211	IA1_Samba	4/4	2	120			:
Brass	Latin	4212	FC1_Samba	4/4	2	120			:
Brass	Latin	4213	MB2_Samba	4/4	4	120			Trombone
Brass	Latin	4214	MC2_Samba	4/4	4	120			:
Brass	World	4215	MC_Turkish	9/8	2	125			Mute Trumpet
Brass	Genrl	4216	MA_Orchestra_XS	4/4	4	102			French Horn
Brass	Genrl	4217	MB_Orchestra_XS	4/4	8	102			:
Brass	Genrl	4218	MC_Orchestra_XS	4/4	8	102			:
Brass	Genrl	4219	MD_Orchestra_XS	4/4	4	102			:
Brass	Genrl	4220	FA_Orchestra_XS	4/4	1	102			:
Brass	Genrl	4221	MB_Baroque_XS	4/4	4	88			Trumpet
Brass	Genrl	4222	MD_Baroque_XS	4/4	4	88			:
Brass	Genrl	4223	FA_Baroque_XS	4/4	1	88			:
Brass	Genrl	4224	FD_Baroque_XS	4/4	1	88			:
Brass	Genrl	4225	MA_Brass Sec1	4/4	1	120			Brass Section
Brass	Genrl	4226	MA_Brass Sec2	4/4	1	123			:
Brass	Genrl	4227	MA_Brass Sec3	4/4	1	120			:

Main Category	Sub Category	ARP No.	ARP Name	Time Signature	Length	Original Tempo	Accent	Random SFX	Voice Type
Brass	Genrl	4228	MA_Brass Sec4	4/4	1	120			Brass Section
Brass	Genrl	4229	MA_Brass Sec5	4/4	1	120			:
Brass	Genrl	4230	MA_Brass Sec6	4/4	1	120			:
Brass	Genrl	4231	MA_Brass Sec7	4/4	1	120			:
RdPp	HipHp	4232	MD_Hip Hop 1_ES	4/4	2	105			Saxophone
RdPp	HipHp	4233	FC_Hip Hop 1_ES	4/4	2	105			:
RdPp	R&B-C	4234	MB_Soul 2_ES	4/4	4	120			:
RdPp	R&B-C	4235	MC_Soul 2_ES	4/4	4	120			:
RdPp	R&B-C	4236	FB_Soul 2_ES	4/4	1	120			:
RdPp	R&B-C	4237	FC_Soul 2_ES	4/4	1	120			:
RdPp	Funk	4238	MA_Club Jazz 2_XS	4/4	4	92			Sax Section
RdPp	Funk	4239	MB_Club Jazz 2_XS	4/4	4	92			:
RdPp	Funk	4240	MC_Club Jazz 2_XS	4/4	4	92			:
RdPp	Funk	4241	FA_Club Jazz 2_XS	4/4	1	92			:
RdPp	Funk	4242	FB_Club Jazz 2_XS	4/4	1	92			:
RdPp	Funk	4243	FC_Club Jazz 2_XS	4/4	1	92			:
RdPp	Funk	4244	BA_Club Jazz 2_XS	4/4	1	92			:
RdPp	Funk	4245	MA_Club Jazz 2_ES	4/4	4	92			:
RdPp	Funk	4246	MB_Club Jazz 2_ES	4/4	4	92			:
RdPp	Funk	4247	MC_Club Jazz 2_ES	4/4	4	92			:
RdPp	Funk	4248	FA_Club Jazz 2_ES	4/4	1	92			:
RdPp	Funk	4249	FB_Club Jazz 2_ES	4/4	1	92			:
RdPp	Funk	4250	FC_Club Jazz 2_ES	4/4	1	92			:
RdPp	Funk	4251	BA_Club Jazz 2_ES	4/4	1	92			:
RdPp	Latin	4252	MA_Samba_ES	4/4	2	120			Saxophone
RdPp	Latin	4253	MC_Samba_ES	4/4	4	120			:
RdPp	Latin	4254	MD_Samba_ES	4/4	4	120			:
RdPp	Latin	4255	FC_Samba_ES	4/4	2	120			:
RdPp	World	4256	MA1_Turkish_ES	4/4	2	105			Ney
RdPp	World	4257	MF1_Turkish_ES	4/4	2	105			:
RdPp	World	4258	MB2_Turkish_ES	4/4	2	105			Saxophone
RdPp	World	4259	MC2_Turkish_ES	9/8	2	125			:
RdPp	World	4260	MD2_Turkish_ES	9/8	2	125			:
RdPp	World	4261	ME2_Turkish	4/4	2	105			:
RdPp	Genrl	4262	MC_Baroque_XS	4/4	4	88			Oboe
RdPp	Genrl	4263	MD_Baroque_XS	4/4	4	88			:
RdPp	Genrl	4264	FB_Baroque_XS	4/4	1	88			:
RdPp	Genrl	4265	FC_Baroque_XS	4/4	1	88			:
RdPp	Genrl	4266	FD_Baroque_XS	4/4	1	88			:
RdPp	Genrl	4267	Flute Accent_ES	4/4	1	102			Flute
RdPp	Genrl	4268	Flute1	4/4	1	120			:
RdPp	Genrl	4269	Flute2	4/4	1	120			:
RdPp	Genrl	4270	Flute3	4/4	1	120			:
RdPp	Genrl	4271	Flutter1	4/4	1	120			Flute/Reed
RdPp	Genrl	4272	Flutter2	4/4	1	120			:
RdPp	Genrl	4273	Flutter3	4/4	1	120			:
Lead	HipHp	4274	MA_DirtySynth	4/4	2	85			Synth Lead
Lead	HipHp	4275	MB_DirtySynth	4/4	2	85			:
Lead	HipHp	4276	MC_DirtySynth	4/4	2	85			:
Lead	HipHp	4277	MD_DirtySynth	4/4	2	85			:
Lead	HipHp	4278	MA_HipHopEpic/1_ES	4/4	2	85			:
Lead	HipHp	4279	MA_HipHopEpic/2_ES	4/4	2	85			:
Lead	HipHp	4280	MA_HipHopEpic/3_ES	4/4	2	85			:
Lead	HipHp	4281	MA_HipHopEpic/4_ES	4/4	2	85			:
Lead	HipHp	4282	MB_Hip Rock 1_XS	4/4	4	90			:
Lead	HipHp	4283	MC_Hip Rock 1_XS	4/4	4	90			:
Lead	HipHp	4284	FA_Hip Rock 1_XS	4/4	1	90			:
Lead	HipHp	4285	FB_Hip Rock 1_XS	4/4	1	90			:
Lead	HipHp	4286	FC_Hip Rock 1_XS	4/4	1	90			:
Lead	HipHp	4287	MA_Regeton_XS	4/4	4	98			:
Lead	HipHp	4288	MB_Regeton_XS	4/4	4	98			:
Lead	HipHp	4289	MC_Regeton_XS	4/4	4	98			:
Lead	HipHp	4290	FA_Regeton_XS	4/4	1	98			:
Lead	HipHp	4291	FB_Regeton_XS	4/4	1	98			:
Lead	HipHp	4292	FC_Regeton_XS	4/4	1	98			:
Lead	HipHp	4293	MA_Rap Lead1	4/4	2	120			:
Lead	HipHp	4294	MA_Rap Lead2	4/4	2	100			:
Lead	R&B-M	4295	MB_R&B Disco_ES	4/4	2	110			:
Lead	R&B-M	4296	MC_R&B Disco_ES	4/4	1	110			:
Lead	R&B-M	4297	MD_R&B Disco_ES	4/4	2	110			:
Lead	R&B-M	4298	FA_R&B Disco_ES	4/4	1	110			:
Lead	R&B-M	4299	FB_R&B Disco_ES	4/4	1	110			:
Lead	R&B-M	4300	FC_R&B Disco_ES	4/4	2	110			:
Lead	R&B-M	4301	MA_R&B Ballad 1_XS	4/4	4	113			:
Lead	R&B-M	4302	MB_R&B Ballad 1_XS	4/4	4	113			:
Lead	R&B-M	4303	MC_R&B Ballad 1_XS	4/4	4	113			:
Lead	R&B-M	4304	FA_R&B Ballad 1_XS	4/4	1	113			:
Lead	R&B-M	4305	FB_R&B Ballad 1_XS	4/4	1	113			:
Lead	R&B-M	4306	FC_R&B Ballad 1_XS	4/4	1	113			:
Lead	Funk	4307	MA_Club Jazz 1_XS	4/4	4	125			:
Lead	Funk	4308	MB_Club Jazz 1_XS	4/4	4	125			:
Lead	Funk	4309	MC_Club Jazz 1_XS	4/4	4</				

Main Category	Sub Category	ARP No.	ARP Name	Time Signature	Length	Original Tempo	Accent	Random SFX	Voice Type
Lead	Funk	4311	FB_Club Jazz 1_XS	4/4	1	125			Synth Lead
Lead	Funk	4312	FC_Club Jazz 1_XS	4/4	1	125			:
Lead	Funk	4313	BA_Club Jazz 1_XS	4/4	1	125			:
Lead	Funk	4314	MA_Club Jazz 1_ES	4/4	2	125			:
Lead	Funk	4315	MB_Club Jazz 1_ES	4/4	4	125			:
Lead	Funk	4316	MC_Club Jazz 1_ES	4/4	4	125			:
Lead	Funk	4317	FA_Club Jazz 1_ES	4/4	1	125			:
Lead	Funk	4318	FB_Club Jazz 1_ES	4/4	1	125			:
Lead	Funk	4319	FC_Club Jazz 1_ES	4/4	1	125			:
Lead	Funk	4320	BA_Club Jazz 1_ES	4/4	1	125			:
Lead	Tekno	4321	MA_Trance 1_XS	4/4	8	142			:
Lead	Tekno	4322	MB_Trance 1_XS	4/4	4	142			:
Lead	Tekno	4323	MC_Trance 1_XS	4/4	16	142			:
Lead	Tekno	4324	FA_Trance 1_XS	4/4	2	142			:
Lead	Tekno	4325	FB_Trance 1_XS	4/4	8	142			:
Lead	Tekno	4326	FC_Trance 1_XS	4/4	8	142			:
Lead	Tekno	4327	BA_Trance 1_XS	4/4	1	142			:
Lead	Tekno	4328	MA_Trance 1_ES	4/4	8	142			:
Lead	Tekno	4329	MB_Trance 1_ES	4/4	4	142			:
Lead	Tekno	4330	MC_Trance 1_ES	4/4	16	142			:
Lead	Tekno	4331	FA_Trance 1_ES	4/4	2	142			:
Lead	Tekno	4332	FB_Trance 1_ES	4/4	8	142			:
Lead	Tekno	4333	FC_Trance 1_ES	4/4	8	142			:
Lead	Tekno	4334	BA_Trance 1_ES	4/4	1	142			:
Lead	Tekno	4335	MA_Trance 3_XS	4/4	2	140			:
Lead	Tekno	4336	MB_Trance 3_XS	4/4	2	140			:
Lead	Tekno	4337	MC_Trance 3_XS	4/4	3	140			:
Lead	Tekno	4338	FA_Trance 3_XS	4/4	2	140			:
Lead	Tekno	4339	FB_Trance 3_XS	4/4	2	140			:
Lead	Tekno	4340	FC_Trance 3_XS	4/4	4	140			:
Lead	Tekno	4341	BA_Trance 3_XS	4/4	1	140			:
Lead	Tekno	4342	MA_Trance 3_ES	4/4	2	140			:
Lead	Tekno	4343	MB_Trance 3_ES	4/4	2	140			:
Lead	Tekno	4344	MC_Trance 3_ES	4/4	3	140			:
Lead	Tekno	4345	FA_Trance 3_ES	4/4	2	140			:
Lead	Tekno	4346	FB_Trance 3_ES	4/4	2	140			:
Lead	Tekno	4347	FC_Trance 3_ES	4/4	4	140			:
Lead	Tekno	4348	BA_Trance 3_ES	4/4	1	140			:
Lead	Tekno	4349	MA_Trance 4_XS	4/4	4	130			:
Lead	Tekno	4350	MB_Trance 4_XS	4/4	2	130			:
Lead	Tekno	4351	MC_Trance 4_XS	4/4	4	130			:
Lead	Tekno	4352	FA_Trance 4_XS	4/4	4	130			:
Lead	Tekno	4353	FB_Trance 4_XS	4/4	2	130			:
Lead	Tekno	4354	FC_Trance 4_XS	4/4	4	130			:
Lead	Tekno	4355	BA_Trance 4_XS	4/4	2	130			:
Lead	Tekno	4356	MA_Trance 4_ES	4/4	4	130			:
Lead	Tekno	4357	MB_Trance 4_ES	4/4	2	130			:
Lead	Tekno	4358	MC_Trance 4_ES	4/4	4	130			:
Lead	Tekno	4359	FA_Trance 4_ES	4/4	4	130			:
Lead	Tekno	4360	FB_Trance 4_ES	4/4	2	130			:
Lead	Tekno	4361	FC_Trance 4_ES	4/4	4	130			:
Lead	Tekno	4362	BA_Trance 4_ES	4/4	2	130			:
Lead	Tekno	4363	MA_Trance Lead1_ES	4/4	8	143			:
Lead	Tekno	4364	MA_Trance Lead2_ES	4/4	2	143			:
Lead	Tekno	4365	MA_Trance Lead3_ES	4/4	2	143			:
Lead	Tekno	4366	MA_Trance Lead4_ES	4/4	1	143			:
Lead	Tekno	4367	MA_Trance Lead5_ES	4/4	2	143			:
Lead	Tekno	4368	MA_Psyche Lead1_ES	4/4	1	143			:
Lead	Tekno	4369	MA_Psyche Lead2_ES	4/4	1	143			:
Lead	Tekno	4370	MA_Psyche Lead3_ES	4/4	1	143			:
Lead	Tekno	4371	MA_Psyche Lead4_ES	4/4	2	143			:
Lead	Tekno	4372	MA_Psyche Lead5_ES	4/4	2	143			:
Lead	D&B	4373	MA_Big Beat 2_ES	4/4	4	145			:
Lead	D&B	4374	MB_Big Beat 2_ES	4/4	8	145			:
Lead	D&B	4375	MC_Big Beat 2_ES	4/4	4	145			:
Lead	D&B	4376	FA_Big Beat 2_ES	4/4	1	145			:
Lead	D&B	4377	FB_Big Beat 2_ES	4/4	1	145			:
Lead	D&B	4378	FC_Big Beat 2_ES	4/4	1	145			:
Lead	D&B	4379	BA_Big Beat 2_ES	4/4	2	145			:
Lead	Genrl	4380	MA_Needlz	4/4	2	132			:
Lead	Genrl	4381	MA_Pretzel	4/4	1	120			:
Lead	Genrl	4382	MA_DitDot	4/4	2	145			:
Lead	Genrl	4383	MA_CurlyQ	4/4	1	145			:
Lead	Genrl	4384	MA_Sproingo	4/4	2	120			:
Lead	Genrl	4385	MA_Bouncy	4/4	1	138			:
PdMe	Rock	4386	MA_16BeatBasic2_XS	4/4	4	77			Synth Pad
PdMe	Rock	4387	MB_16BeatBasic2_XS	4/4	4	77			:
PdMe	Rock	4388	MC_16BeatBasic2_XS	4/4	4	77			:
PdMe	Rock	4389	FA_16BeatBasic2_XS	4/4	1	77			:
PdMe	Rock	4390	FB_16BeatBasic2_XS	4/4	1	77			:
PdMe	Rock	4391	FC_16BeatBasic2_XS	4/4	1	77			:
PdMe	Rock	4392	BA_16BeatBasic2_XS	4/4	1	77			:
PdMe	Rock	4393	MA_16BeatBasic2_ES	4/4	4	77			:

Main Category	Sub Category	ARP No.	ARP Name	Time Signature	Length	Original Tempo	Accent	Random SFX	Voice Type
PdMe	Rock	4394	MB_16BeatBasic2_ES	4/4	4	77			Synth Pad
PdMe	Rock	4395	MC_16BeatBasic2_ES	4/4	4	77			:
PdMe	Rock	4396	FA_16BeatBasic2_ES	4/4	1	77			:
PdMe	Rock	4397	FB_16BeatBasic2_ES	4/4	1	77			:
PdMe	Rock	4398	FC_16BeatBasic2_ES	4/4	1	77			:
PdMe	Rock	4399	BA_16BeatBasic2_ES	4/4	1	77			:
PdMe	Rock	4400	MA_16Beat Rock_XS	4/4	4	86			:
PdMe	Rock	4401	MB_16Beat Rock_XS	4/4	4	86			:
PdMe	Rock	4402	MC_16Beat Rock_XS	4/4	4	86			:
PdMe	Rock	4403	FA_16Beat Rock_XS	4/4	1	86			:
PdMe	Rock	4404	FB_16Beat Rock_XS	4/4	1	86			:
PdMe	Rock	4405	FC_16Beat Rock_XS	4/4	1	86			:
PdMe	Rock	4406	BA_16Beat Rock_XS	4/4	1	86			:
PdMe	Rock	4407	MA_16Beat Rock_ES	4/4	4	86			:
PdMe	Rock	4408	MB_16Beat Rock_ES	4/4	4	86			:
PdMe	Rock	4409	MC_16Beat Rock_ES	4/4	4	86			:
PdMe	Rock	4410	FA_16Beat Rock_ES	4/4	1	86			:
PdMe	Rock	4411	FB_16Beat Rock_ES	4/4	1	86			:
PdMe	Rock	4412	FC_16Beat Rock_ES	4/4	1	86			:
PdMe	Rock	4413	BA_16Beat Rock_ES	4/4	1	86			:
PdMe	PopRk	4414	MA_16Beat Pop 1_XS	4/4	4	103			:
PdMe	PopRk	4415	MB_16Beat Pop 1_XS	4/4	4	103			:
PdMe	PopRk	4416	MC_16Beat Pop 1_XS	4/4	4	103			:
PdMe	PopRk	4417	FA_16Beat Pop 1_XS	4/4	1	103			:
PdMe	PopRk	4418	FB_16Beat Pop 1_XS	4/4	1	103			:
PdMe	PopRk	4419	FC_16Beat Pop 1_XS	4/4	1	103			:
PdMe	PopRk	4420	BA_16Beat Pop 1_XS	4/4	1	103			:
PdMe	PopRk	4421	MA_16Beat Pop 1_ES	4/4	4	103			:
PdMe	PopRk	4422	MB_16Beat Pop 1_ES	4/4	4	103			:
PdMe	PopRk	4423	MC_16Beat Pop 1_ES	4/4	4	103			:
PdMe	PopRk	4424	FA_16Beat Pop 1_ES	4/4	1	103			:
PdMe	PopRk	4425	FB_16Beat Pop 1_ES	4/4	1	103			:
PdMe	PopRk	4426	FC_16Beat Pop 1_ES	4/4	1	103			:
PdMe	PopRk	4427	BA_16Beat Pop 1_ES	4/4	1	103			:
PdMe	PopRk	4428	MA_16Beat Pop 2_XS	4/4	4	94			:
PdMe	PopRk	4429	MB_16Beat Pop 2_XS	4/4	4	94			:
PdMe	PopRk	4430	MC_16Beat Pop 2_XS	4/4	4	94			:
PdMe	PopRk	4431	FA_16Beat Pop 2_XS	4/4	1	94			:
PdMe	PopRk	4432	FB_16Beat Pop 2_XS	4/4	1	94			:
PdMe	PopRk	4433	FC_16Beat Pop 2_XS	4/4	1	94			:
PdMe	PopRk	4434	BA_16Beat Pop 2_XS	4/4	1	94			:
PdMe	PopRk	4435	MA_16Beat Pop 2_ES	4/4	4	94			:
PdMe	PopRk	4436	MB_16Beat Pop 2_ES	4/4	4	94			:
PdMe	PopRk	4437	MC_16Beat Pop 2_ES	4/4	4	94			:
PdMe	PopRk	4438	FA_16Beat Pop 2_ES	4/4	1	94			:
PdMe	PopRk	4439	FB_16Beat Pop 2_ES	4/4	1	94			:
PdMe	PopRk	4440	FC_16Beat Pop 2_ES	4/4	1	94			:
PdMe	PopRk	4441	BA_16Beat Pop 2_ES	4/4	1	94			:
PdMe	PopRk	4442	MC_Analog Pop	4/4	1	93			:
PdMe	PopRk	4443	MD_Analog Pop	4/4	1	93			:
PdMe	HipHp	4444	IA_Hip Hop 2	4/4	1	94			Hit
PdMe	HipHp	4445	FC_Hip Hop 2_ES	4/4	2	94			:
PdMe	R&B-M	4446	MA_Pop Shuffle2_XS	4/4	4	80			Synth Pad
PdMe	R&B-M	4447	MB_Pop Shuffle2_XS	4/4	4	80			:
PdMe	R&B-M	4448	MC_Pop Shuffle2_XS	4/4	4	80			:
PdMe	R&B-M	4449	FA_Pop Shuffle2_XS	4/4	1	80			:
PdMe	R&B-M	4450	FB_Pop Shuffle2_XS	4/4	1	80			:
PdMe	R&B-M	4451	FC_Pop Shuffle2_XS	4/4	1	80			:
PdMe	R&B-M	4452	BA_Pop Shuffle2_XS	4/4	1	80			:
PdMe	R&B-M	4453	MA_Pop Shuffle2_ES	4/4	4	80			:
PdMe	R&B-M	4454	MB_Pop Shuffle2_ES	4/4	4	80			:
PdMe	R&B-M	4455	MC_Pop Shuffle2_ES	4/4	4	80			:
PdMe	R&B-M	4456	FA_Pop Shuffle2_ES	4/4	1	80			:
PdMe	R&B-M	4457	FB_Pop Shuffle2_ES	4/4	1	80			:
PdMe	R&B-M	4458	FC_Pop Shuffle2_ES	4/4	1	80			:
PdMe	R&B-M	4459	BA_Pop Shuffle2_ES	4/4	1	80			:
PdMe	R&B-M	4460	MA_Chart R&B_XS	4/4	4	130			:
PdMe	R&B-M	4461	MB_Chart R&B_XS	4/4	4	130			:
PdMe	R&B-M	4462	MC_Chart R&B_XS	4/4	4	130			:
PdMe	R&B-M	4463	FA_Chart R&B_XS	4/4	1	130			:
PdMe	R&B-M	4464	FB_Chart R&B_XS	4/4	1	130			:
PdMe	R&B-M	4465	FC_Chart R&B_XS	4/4	1	130			:
PdMe	R&B-M	4466	BA_Chart R&B_XS	4/4	1	130			:
PdMe	R&B-M	4467	EA_Chart R&B_XS	4/4	5	130			:
PdMe	R&B-M	4468	EB_Chart R&B_XS	4/4	10	130			:
PdMe	R&B-M	4469	MA_J-R&B Pop_XS	4/4	4	100			Hit
PdMe	R&B-M	4470	MB_J-R&B Pop_XS	4/4	4	100			:
PdMe	R&B-M	4471	MC_J-R&B Pop_XS	4/4	4	100			:
PdMe	R&B-M	4472	FA_J-R&B Pop_XS	4/4	1	100			:
PdMe	R&B-M	4473	FB_J-R&B Pop_XS	4/4	1	100			:

Arpeggio Type List

Main Category	Sub Category	ARP No.	ARP Name	Time Signature	Length	Original Tempo	Accent	Random SFX	Voice Type
PdMe	Tekno	4477	MA1_Tekno 1_ES	4/4	4	135			Synth Pad
PdMe	Tekno	4478	MB1_Tekno 1_ES	4/4	8	135			:
PdMe	Tekno	4479	MC1_Tekno 1_ES	4/4	8	135			:
PdMe	Tekno	4480	FA1_Tekno 1_ES	4/4	1	135			:
PdMe	Tekno	4481	FB1_Tekno 1_ES	4/4	1	135			:
PdMe	Tekno	4482	BA1_Tekno 1_ES	4/4	4	135			:
PdMe	Tekno	4483	MC2_Tekno 1_ES	4/4	8	135			:
PdMe	Chill	4484	MA_Ambient 5	4/4	4	112			:
PdMe	Chill	4485	MA_Ambient 5 AF1	4/4	4	112			:
PdMe	Chill	4486	MA_Ambient 5 AF1&2	4/4	4	112			:
PdMe	Genrl	4487	MA_Cycle1	4/4	3	120			:
PdMe	Genrl	4488	MA_Cycle2	4/4	6	120			:
PdMe	Genrl	4489	MA_Cycle3_ES	4/4	14	118			:
PdMe	Genrl	4490	MA_Ripples_ES	4/4	4	82			:
PdMe	Genrl	4491	MA_PulsPad	4/4	4	120			:
CPrc	R&B-M	4492	FB_R&B Disco_ES	4/4	1	110			Chromatic Perc.
CPrc	R&B-M	4493	FC_R&B Disco_ES	4/4	2	110			:
CPrc	Tekno	4494	MC_Trance 5	4/4	4	140			:
CPrc	World	4495	MA_Ethnic1	6/4	5	118			:
CPrc	World	4496	MA_Ethnic2	7/4	3	120			:
CPrc	Genrl	4497	MA_Synth Bell_ES	4/4	2	90			:
CPrc	Genrl	4498	MB_Synth Bell_ES	4/4	4	90			:
CPrc	Genrl	4499	MC_Synth Bell_ES	4/4	2	90			:
CPrc	Genrl	4500	MD_Synth Bell_ES	4/4	4	90			:
CPrc	Genrl	4501	ME_Synth Bell_ES	4/4	4	90			:
CPrc	Genrl	4502	EA_Synth Bell_ES	4/4	4	90			:
CPrc	Genrl	4503	MA_Tubular Bell_ES	4/4	2	100			Tubular Bell
CPrc	Genrl	4504	MB_Tubular Bell_ES	4/4	2	100			:
CPrc	Genrl	4505	MC_Tubular Bell_ES	4/4	4	100			:
CPrc	Genrl	4506	MD_Tubular Bell_ES	4/4	2	100			:
CPrc	Genrl	4507	ME_Tubular Bell_ES	4/4	1	100			:
CPrc	Genrl	4508	MA_Real Timpani_ES	4/4	2	120			*Real Timpani AF2 MII*
CPrc	Genrl	4509	MB_Real Timpani_ES	4/4	2	120			:
CPrc	Genrl	4510	MC_Real Timpani_ES	4/4	3	120			:
CPrc	Genrl	4511	MD_Real Timpani_ES	4/4	1	120			:
CPrc	Genrl	4512	ME_Real Timpani_ES	4/4	3	120			:
CPrc	Genrl	4513	MF_Real Timpani_ES	4/4	6	120			:
CPrc	Genrl	4514	MA_RealTimpan AF2_ES	4/4	2	110			:
CPrc	Genrl	4515	MB_RealTimpan AF2_ES	4/4	1	110			:
CPrc	Genrl	4516	MC_RealTimpan AF2_ES	4/4	2	110			:
CPrc	Genrl	4517	MD_RealTimpan AF2_ES	4/4	2	110			:
CPrc	Genrl	4518	ME_RealTimpan AF2_ES	4/4	2	110			:
CPrc	Genrl	4519	Timpani Roll_ES	4/4	1	102			Timpani
CPrc	Genrl	4520	Mallet Roll1	4/4	2	120			Chromatic Perc.
CPrc	Genrl	4521	Mallet Roll2	4/4	2	120			:
CPrc	Genrl	4522	MOD1	4/4	1	120			:
CPrc	Genrl	4523	MOD2	4/4	2	120			:
CPrc	Genrl	4524	MOD3	4/4	1	120			:
CPrc	Genrl	4525	Trill 1	4/4	1	120			:
CPrc	Genrl	4526	Trill 2	4/4	2	120			:
CPrc	Genrl	4527	Trill 3	4/4	2	120			:
CPrc	Genrl	4528	Steel Drum1	4/4	1	160			Steel Drum
CPrc	Genrl	4529	Steel Drum2	4/4	2	95			:
CPrc	Genrl	4530	Bell Tree1	4/4	3	120			Chromatic Perc.
CPrc	Genrl	4531	Bell Tree2	4/4	3	120			:
CPrc	Genrl	4532	Crescendo	4/4	1	120			:
DrPc	Rock	4533	MA_StandardRock	4/4	4	131	○		*Power Standard Kit 2*
DrPc	Rock	4534	MB_StandardRock	4/4	4	131	○		:
DrPc	Rock	4535	MC_StandardRock	4/4	4	131	○		:
DrPc	Rock	4536	FA_StandardRock	4/4	1	131	○		:
DrPc	Rock	4537	FB_StandardRock	4/4	1	131	○		:
DrPc	Rock	4538	FC_StandardRock	4/4	1	131	○		:
DrPc	Rock	4539	BA_StandardRock	4/4	1	131	○		:
DrPc	Rock	4540	EA_StandardRock	4/4	4	131	○		:
DrPc	Rock	4541	EB_StandardRock	4/4	6	131	○		:
DrPc	Rock	4542	MA_Power Rock	4/4	4	120	○		*Power Standard Kit 1*
DrPc	Rock	4543	MB_Power Rock	4/4	4	120	○		:
DrPc	Rock	4544	MC_Power Rock	4/4	4	120	○		:
DrPc	Rock	4545	FA_Power Rock	4/4	1	120	○		:
DrPc	Rock	4546	FB_Power Rock	4/4	1	120	○		:
DrPc	Rock	4547	FC_Power Rock	4/4	1	120	○		:
DrPc	Rock	4548	BA_Power Rock	4/4	1	120	○		:
DrPc	Rock	4549	EA_Power Rock	4/4	4	120	○		:
DrPc	Rock	4550	EB_Power Rock	4/4	7	120	○		:
DrPc	Rock	4551	MA_ContempRock	4/4	4	126	○		*Power Standard Kit 2*
DrPc	Rock	4552	MB_ContempRock	4/4	4	126	○		:
DrPc	Rock	4553	MC_ContempRock	4/4	4	126	○		:
DrPc	Rock	4554	FA_ContempRock	4/4	1	126	○		:
DrPc	Rock	4555	FB_ContempRock	4/4	1	126	○		:
DrPc	Rock	4556	FC_ContempRock	4/4	1	126	○		:
DrPc	Rock	4557	BA_ContempRock	4/4	1	126	○		:
DrPc	Rock	4558	EA_ContempRock	4/4	4	126	○		:
DrPc	Rock	4559	EB_ContempRock	4/4	4	126	○		:

Main Category	Sub Category	ARP No.	ARP Name	Time Signature	Length	Original Tempo	Accent	Random SFX	Voice Type
DrPc	Rock	4560	MA_Hard Rock	4/4	4	120	○		*Power Standard Kit 1*
DrPc	Rock	4561	MB_Hard Rock	4/4	4	120	○		:
DrPc	Rock	4562	MC_Hard Rock	4/4	4	120	○		:
DrPc	Rock	4563	FA_Hard Rock	4/4	1	120	○		:
DrPc	Rock	4564	FB_Hard Rock	4/4	1	120	○		:
DrPc	Rock	4565	FC_Hard Rock	4/4	1	120	○		:
DrPc	Rock	4566	BA_Hard Rock	4/4	1	120	○		:
DrPc	Rock	4567	EA_Hard Rock	4/4	3	120	○		:
DrPc	Rock	4568	EB_Hard Rock	4/4	6	120	○		:
DrPc	Rock	4569	MA_70s Rock	4/4	4	130	○		*Dry Standard Kit*
DrPc	Rock	4570	MB_70s Rock	4/4	4	130	○		:
DrPc	Rock	4571	MC_70s Rock	4/4	4	130	○		:
DrPc	Rock	4572	MD_70s Rock	4/4	4	130	○		:
DrPc	Rock	4573	IA_70s Rock	4/4	1	130	○		:
DrPc	Rock	4574	FA_70s Rock	4/4	1	130	○		:
DrPc	Rock	4575	FB_70s Rock	4/4	1	130	○		:
DrPc	Rock	4576	FC_70s Rock	4/4	2	130	○		:
DrPc	Rock	4577	MA_Blues Rock	4/4	4	120	○		*Power Standard Kit 1*
DrPc	Rock	4578	MB_Blues Rock	4/4	4	120	○		:
DrPc	Rock	4579	MC_Blues Rock	4/4	4	120	○		:
DrPc	Rock	4580	FA_Blues Rock	4/4	1	120	○		:
DrPc	Rock	4581	FB_Blues Rock	4/4	1	120	○		:
DrPc	Rock	4582	FC_Blues Rock	4/4	1	120	○		:
DrPc	Rock	4583	BA_Blues Rock	4/4	1	120	○		:
DrPc	Rock	4584	EA_Blues Rock	4/4	3	120	○		:
DrPc	Rock	4585	EB_Blues Rock	4/4	5	120	○		:
DrPc	Rock	4586	MA_RockShuffle	4/4	4	121	○		*Power Standard Kit 2*
DrPc	Rock	4587	MB_RockShuffle	4/4	4	121	○		:
DrPc	Rock	4588	MC_RockShuffle	4/4	4	121	○		:
DrPc	Rock	4589	FA_RockShuffle	4/4	1	121	○		:
DrPc	Rock	4590	FB_RockShuffle	4/4	1	121	○		:
DrPc	Rock	4591	FC_RockShuffle	4/4	1	121	○		:
DrPc	Rock	4592	BA_RockShuffle	4/4	1	121	○		:
DrPc	Rock	4593	EA_RockShuffle	4/4	6	121	○		:
DrPc	Rock	4594	MA_Rock & Roll	4/4	4	172	○		:
DrPc	Rock	4595	MB_Rock & Roll	4/4	4	172	○		:
DrPc	Rock	4596	MC_Rock & Roll	4/4	4	172	○		:
DrPc	Rock	4597	FA_Rock & Roll	4/4	1	172	○		:
DrPc	Rock	4598	FB_Rock & Roll	4/4	1	172	○		:
DrPc	Rock	4599	FC_Rock & Roll	4/4	1	172	○		:
DrPc	Rock	4600	BA_Rock & Roll	4/4	1	172	○		:
DrPc	Rock	4601	EA_Rock & Roll	4/4	5	172	○		:
DrPc	Rock	4602	EB_Rock & Roll	4/4	6	172	○		:
DrPc	Rock	4603	MA1_AlternaRock1	4/4	4	97	○		*Modern Rock Kit*
DrPc	Rock	4604	MB1_AlternaRock1	4/4	4	97	○		:
DrPc	Rock	4605	MC1_AlternaRock1	4/4	4	97	○		:
DrPc	Rock	4606	FA1_AlternaRock1	4/4	1	97	○		:
DrPc	Rock	4607	FB1_AlternaRock1	4/4	1	97	○		:
DrPc	Rock	4608	FC1_AlternaRock1	4/4	1	97	○		:
DrPc	Rock	4609	BA1_AlternaRock1	4/4	1	97	○		:
DrPc	Rock	4610	MA2_8Z Alterna1	4/4	4	97	○		*8Z Romps*
DrPc	Rock	4611	MB2_8Z Alterna1	4/4	4	97	○		:
DrPc	Rock	4612	MC2_8Z Alterna1	4/4	4	97	○		:
DrPc	Rock	4613	FA2_8Z Alterna1	4/4	1	97	○		:
DrPc	Rock	4614	FB2_8Z Alterna1	4/4	1	97	○		:
DrPc	Rock	4615	FC2_8Z Alterna1	4/4	1	97	○		:
DrPc	Rock	4616	BA2_8Z Alterna1	4/4	1	97	○		:
DrPc	Rock	4617	MA_AlternaRock2	4/4	4	100	○		*Rock Stereo Kit 2*
DrPc	Rock	4618	MB_AlternaRock2	4/4	4	100	○		:
DrPc	Rock	4619	MC_AlternaRock2	4/4	4	100	○		:
DrPc	Rock	4620	FA_AlternaRock2	4/4	1	100	○		:
DrPc	Rock	4621	FB_AlternaRock2	4/4	1	100	○		:
DrPc	Rock	4622	FC_AlternaRock2	4/4	1	100	○		:
DrPc	Rock	4623	BA_AlternaRock2	4/4	2	100	○		:
DrPc	Rock	4624	MA_Mondo Rock	4/4	2	94	○		:
DrPc	Rock	4625	MB_Mondo Rock	4/4	2	94	○		:
DrPc	Rock	4626	MC_Mondo Rock	4/4	2	94	○		:
DrPc	Rock	4627	MD_Mondo Rock	4/4	4	94	○		:
DrPc	Rock	4628	MA1_Xover Rock	4/4	2	100	○		*Rock Stereo Kit 1*
DrPc	Rock	4629	MB1_Xover Rock	4/4	1	100	○		:
DrPc	Rock	4630	MC1_Xover Rock	4/4	2	100	○		:
DrPc	Rock	4631	MD1_Xover Rock	4/4	2	100	○		:
DrPc	Rock	4632	IA1_Xover Rock	4/4	2	100	○		:
DrPc	Rock	4633	FA1_Xover Rock	4/4	1	100	○		:
DrPc	Rock	4634	FB1_Xover Rock	4/4	1	100	○		:
DrPc	Rock	4635	FC1_Xover Rock	4/4	2	100	○		:
DrPc	Rock	4636	FA2_Xover Rock	4/4	1	100	○		*Scratches*
DrPc	Rock	4637	FC2_Xover Rock	4/4	1	100	○		:
DrPc	Rock	4638	MA_8Beat Rock	4/4	4	75	○		*Power Standard Kit 2*
DrPc	Rock	4639	MB_8Beat Rock	4/4	4	75	○		:

Arpeggio Type List

Main Category	Sub Category	ARP No.	ARP Name	Time Signature	Length	Original Tempo	Accent	Random SFX	Voice Type
DrPc	Rock	4643	FC_8Beat Rock	4/4	1	75	○		"Power Standard Kit 2"
DrPc	Rock	4644	BA_8Beat Rock	4/4	1	75	○		:
DrPc	Rock	4645	MA_16Beat Rock	4/4	4	86	○		"Rock Stereo Kit 2"
DrPc	Rock	4646	MB_16Beat Rock	4/4	4	86	○		:
DrPc	Rock	4647	MC_16Beat Rock	4/4	4	86	○		:
DrPc	Rock	4648	FA_16Beat Rock	4/4	1	86	○		:
DrPc	Rock	4649	FB_16Beat Rock	4/4	1	86	○		:
DrPc	Rock	4650	FC_16Beat Rock	4/4	1	86	○		:
DrPc	Rock	4651	BA_16Beat Rock	4/4	1	86	○		:
DrPc	Rock	4652	MA_ProgresRock1	4/4	4	110	○		"Modern Rock Kit"
DrPc	Rock	4653	MB_ProgresRock1	4/4	3	110	○		:
DrPc	Rock	4654	MC_ProgresRock1	4/4	4	110	○		:
DrPc	Rock	4655	FA_ProgresRock1	4/4	1	110	○		:
DrPc	Rock	4656	FB_ProgresRock1	4/4	1	110	○		:
DrPc	Rock	4657	FC_ProgresRock1	4/4	1	110	○		:
DrPc	Rock	4658	BA_ProgresRock1	4/4	1	110	○		:
DrPc	Rock	4659	MA_ProgresRock2	4/4	4	120	○		"Power Standard Kit 2"
DrPc	Rock	4660	MB_ProgresRock2	4/4	4	120	○		:
DrPc	Rock	4661	MC_ProgresRock2	4/4	4	120	○		:
DrPc	Rock	4662	FA_ProgresRock2	4/4	1	120	○		:
DrPc	Rock	4663	FB_ProgresRock2	4/4	1	120	○		:
DrPc	Rock	4664	FC_ProgresRock2	4/4	1	120	○		:
DrPc	Rock	4665	BA_ProgresRock2	4/4	1	120	○		:
DrPc	Rock	4666	MA_Maple Custom	4/4	4	150	○		"Maple Custom Kit"
DrPc	Rock	4667	MB_Maple Custom	4/4	2	150	○		:
DrPc	Rock	4668	MC_Maple Custom	4/4	4	150	○		:
DrPc	Rock	4669	MD_Maple Custom	4/4	4	150	○		:
DrPc	Rock	4670	FA_Maple Custom	4/4	2	150	○		:
DrPc	Rock	4671	BA_Maple Custom	4/4	2	150	○		:
DrPc	Rock	4672	EA_Maple Custom	4/4	7	150	○		:
DrPc	PopRk	4673	MA_Pop Rock 1	4/4	2	120	○		"Rock Stereo Kit 2"
DrPc	PopRk	4674	MB_Pop Rock 1	4/4	2	120	○		:
DrPc	PopRk	4675	MC_Pop Rock 1	4/4	2	120	○		:
DrPc	PopRk	4676	MD_Pop Rock 1	4/4	2	120	○		:
DrPc	PopRk	4677	MA_Pop Rock 2	4/4	2	126	○		"Rock Stereo Kit 1"
DrPc	PopRk	4678	MB_Pop Rock 2	4/4	2	126	○		:
DrPc	PopRk	4679	MC_Pop Rock 2	4/4	2	126	○		:
DrPc	PopRk	4680	MD_Pop Rock 2	4/4	2	126	○		:
DrPc	PopRk	4681	MA_Pop Rock 3	4/4	2	120	○		"Rock Stereo Kit 2"
DrPc	PopRk	4682	MA_Pop Rock 4	4/4	2	115	○		:
DrPc	PopRk	4683	MA_Guitar Pop 1	4/4	4	100	○		"Power Standard Kit 1"
DrPc	PopRk	4684	MB_Guitar Pop 1	4/4	4	100	○		:
DrPc	PopRk	4685	MC_Guitar Pop 1	4/4	4	100	○		:
DrPc	PopRk	4686	FA_Guitar Pop 1	4/4	1	100	○		:
DrPc	PopRk	4687	FB_Guitar Pop 1	4/4	1	100	○		:
DrPc	PopRk	4688	FC_Guitar Pop 1	4/4	1	100	○		:
DrPc	PopRk	4689	BA_Guitar Pop 1	4/4	1	100	○		:
DrPc	PopRk	4690	EA_Guitar Pop 1	4/4	3	100	○		:
DrPc	PopRk	4691	EB_Guitar Pop 1	4/4	3	100	○		:
DrPc	PopRk	4692	MA1_Guitar Pop 2	4/4	2	90	○		"Dry Standard Kit"
DrPc	PopRk	4693	MB1_Guitar Pop 2	4/4	1	90	○		:
DrPc	PopRk	4694	MC1_Guitar Pop 2	4/4	2	90	○		:
DrPc	PopRk	4695	MD1_Guitar Pop 2	4/4	2	90	○		:
DrPc	PopRk	4696	IA1_Guitar Pop 2	4/4	2	90	○		:
DrPc	PopRk	4697	FA1_Guitar Pop 2	4/4	1	90	○		:
DrPc	PopRk	4698	FB1_Guitar Pop 2	4/4	1	90	○		:
DrPc	PopRk	4699	FC1_Guitar Pop 2	4/4	2	90	○		:
DrPc	PopRk	4700	MC2_Guitar Pop 2	4/4	2	90	○		"Latin Percussion Kit"
DrPc	PopRk	4701	MD2_Guitar Pop 2	4/4	2	90	○		:
DrPc	PopRk	4702	FA2_Guitar Pop 2	4/4	1	90	○		:
DrPc	PopRk	4703	FC2_Guitar Pop 2	4/4	2	90	○		:
DrPc	PopRk	4704	MA_Acoustic Pop	4/4	4	110	○		"Chill Out Kit"
DrPc	PopRk	4705	MB_Acoustic Pop	4/4	4	110	○		:
DrPc	PopRk	4706	MC_Acoustic Pop	4/4	4	110	○		:
DrPc	PopRk	4707	FA_Acoustic Pop	4/4	1	110	○		:
DrPc	PopRk	4708	FB_Acoustic Pop	4/4	1	110	○		:
DrPc	PopRk	4709	FC_Acoustic Pop	4/4	1	110	○		:
DrPc	PopRk	4710	BA_Acoustic Pop	4/4	1	110	○		:
DrPc	PopRk	4711	MA_FingerPickin	4/4	4	94	○		"Dry Standard Kit"
DrPc	PopRk	4712	MB_FingerPickin	4/4	4	94	○		:
DrPc	PopRk	4713	MC_FingerPickin	4/4	4	94	○		:
DrPc	PopRk	4714	MD_FingerPickin	4/4	4	94	○		:
DrPc	PopRk	4715	IA_FingerPickin/a	4/4	1	94	○		:
DrPc	PopRk	4716	IA_FingerPickin/b	4/4	1	94	○		:
DrPc	PopRk	4717	FA_FingerPickin	4/4	1	94	○		:
DrPc	PopRk	4718	FB_FingerPickin	4/4	1	94	○		:
DrPc	PopRk	4719	FC_FingerPickin	4/4	1	94	○		:
DrPc	PopRk	4720	MA_Folk Rock	4/4	1	120	○		:
DrPc	PopRk	4721	MB_Folk Rock/1	4/4	4	120	○		:
DrPc	PopRk	4722	MD_Folk Rock	4/4	1	120	○		:
DrPc	PopRk	4723	IA_Folk Rock	4/4	1	120	○		:
DrPc	PopRk	4724	FA_Folk Rock	4/4	1	120	○		:
DrPc	PopRk	4725	FB_Folk Rock	4/4	1	120	○		:

Main Category	Sub Category	ARP No.	ARP Name	Time Signature	Length	Original Tempo	Accent	Random SFX	Voice Type
DrPc	PopRk	4726	FC_Folk Rock	4/4	1	120	○		"Dry Standard Kit"
DrPc	PopRk	4727	MB_Folk Rock/2	4/4	1	120	○		:
DrPc	PopRk	4728	MA_Worship Slow	4/4	4	75	○		"Power Standard Kit 1"
DrPc	PopRk	4729	MB_Worship Slow	4/4	4	75	○		:
DrPc	PopRk	4730	MC_Worship Slow	4/4	4	75	○		:
DrPc	PopRk	4731	FA_Worship Slow	4/4	1	75	○		:
DrPc	PopRk	4732	FB_Worship Slow	4/4	1	75	○		:
DrPc	PopRk	4733	FC_Worship Slow	4/4	1	75	○		:
DrPc	PopRk	4734	BA_Worship Slow	4/4	1	75	○		:
DrPc	PopRk	4735	EA_Worship Slow	4/4	4	75	○		:
DrPc	PopRk	4736	EB_Worship Slow	4/4	4	75	○		:
DrPc	PopRk	4737	MA_Worship Med	4/4	8	140	○		"Brush Kit"
DrPc	PopRk	4738	MB_Worship Med	4/4	4	140	○		:
DrPc	PopRk	4739	MC_Worship Med	4/4	4	140	○		:
DrPc	PopRk	4740	FA_Worship Med	4/4	1	140	○		:
DrPc	PopRk	4741	FB_Worship Med	4/4	1	140	○		:
DrPc	PopRk	4742	FC_Worship Med	4/4	1	140	○		:
DrPc	PopRk	4743	BA_Worship Med	4/4	1	140	○		:
DrPc	PopRk	4744	EA_Worship Med	4/4	4	140	○		:
DrPc	PopRk	4745	EB_Worship Med	4/4	4	140	○		:
DrPc	PopRk	4746	MA_Worship Fast	4/4	8	114	○		"Power Standard Kit 2"
DrPc	PopRk	4747	MB_Worship Fast	4/4	4	114	○		:
DrPc	PopRk	4748	MC_Worship Fast	4/4	4	114	○		:
DrPc	PopRk	4749	FA_Worship Fast	4/4	1	114	○		:
DrPc	PopRk	4750	FB_Worship Fast	4/4	1	114	○		:
DrPc	PopRk	4751	FC_Worship Fast	4/4	1	114	○		:
DrPc	PopRk	4752	BA_Worship Fast	4/4	1	114	○		:
DrPc	PopRk	4753	EA_Worship Fast	4/4	4	114	○		:
DrPc	PopRk	4754	EB_Worship Fast	4/4	2	114	○		:
DrPc	PopRk	4755	MA_New Country	4/4	2	118	○		"Power Standard Kit 1"
DrPc	PopRk	4756	MB_New Country	4/4	4	118	○		:
DrPc	PopRk	4757	MC_New Country	4/4	2	118	○		:
DrPc	PopRk	4758	FA_New Country	4/4	1	118	○		:
DrPc	PopRk	4759	FB_New Country	4/4	1	118	○		:
DrPc	PopRk	4760	FC_New Country	4/4	1	118	○		:
DrPc	PopRk	4761	BA_New Country	4/4	1	118	○		:
DrPc	PopRk	4762	EA_New Country	4/4	4	118	○		:
DrPc	PopRk	4763	EB_New Country	4/4	4	118	○		:
DrPc	PopRk	4764	MA_VintageGIPop	4/4	4	148	○		:
DrPc	PopRk	4765	MB_VintageGIPop	4/4	4	148	○		:
DrPc	PopRk	4766	MC_VintageGIPop	4/4	4	148	○		:
DrPc	PopRk	4767	FA_VintageGIPop	4/4	1	148	○		:
DrPc	PopRk	4768	FB_VintageGIPop	4/4	1	148	○		:
DrPc	PopRk	4769	FC_VintageGIPop	4/4	1	148	○		:
DrPc	PopRk	4770	BA_VintageGIPop	4/4	1	148	○		:
DrPc	PopRk	4771	EA_VintageGIPop	4/4	4	148	○		:
DrPc	PopRk	4772	EB_VintageGIPop	4/4	4	148	○		:
DrPc	PopRk	4773	MA_WestCoastPop	4/4	4	100	○		:
DrPc	PopRk	4774	MB_WestCoastPop	4/4	4	100	○		:
DrPc	PopRk	4775	MC_WestCoastPop	4/4	4	100	○		:
DrPc	PopRk	4776	FA_WestCoastPop	4/4	1	100	○		:
DrPc	PopRk	4777	FB_WestCoastPop	4/4	1	100	○		:
DrPc	PopRk	4778	FC_WestCoastPop	4/4	1	100	○		:
DrPc	PopRk	4779	BA_WestCoastPop	4/4	1	100	○		:
DrPc	PopRk	4780	EA_WestCoastPop	4/4	4	100	○		:
DrPc	PopRk	4781	EB_WestCoastPop	4/4	4	100	○		:
DrPc	PopRk	4782	MA_Brit Pop	4/4	2	86	○		"Brush Kit"
DrPc	PopRk	4783	MB_Brit Pop	4/4	2	86	○		:
DrPc	PopRk	4784	MC_Brit Pop	4/4	2	86	○		:
DrPc	PopRk	4785	FA_Brit Pop	4/4	1	86	○		:
DrPc	PopRk	4786	FB_Brit Pop	4/4	1	86	○		:
DrPc	PopRk	4787	FC_Brit Pop	4/4	1	86	○		:
DrPc	PopRk	4788	BA_Brit Pop	4/4	1	86	○		:
DrPc	PopRk	4789	EA_Brit Pop	4/4	4	86	○		:
DrPc	PopRk	4790	EB_Brit Pop	4/4	4	86	○		:
DrPc	PopRk	4791	MA_BritPopSwing	4/4	2	110	○		"Power Standard Kit 1"
DrPc	PopRk	4792	MB_BritPopSwing	4/4	2	110	○		:
DrPc	PopRk	4793	MC_BritPopSwing	4/4	2	110	○		:
DrPc	PopRk	4794	FA_BritPopSwing	4/4	1	110	○		:
DrPc	PopRk	4795	FB_BritPopSwing	4/4	1	110	○		:
DrPc	PopRk	4796	FC_BritPopSwing	4/4	1	110	○		:
DrPc	PopRk	4797	BA_BritPopSwing	4/4	1	110	○		:
DrPc	PopRk	4798	EA_BritPopSwing	4/4	4	110	○		:
DrPc	PopRk	4799	EB_BritPopSwing	4/4	4	110	○		:
DrPc	PopRk	4800	MA_Cool 8Beat	4/4	2	100	○		:
DrPc	PopRk	4							

Arpeggio Type List

Main Category	Sub Category	ARP No.	ARP Name	Time Signature	Length	Original Tempo	Accent	Random SFX	Voice Type
DrPc	PopRk	4809	MA_8Beat Basic	4/4	4	120	○		"Power Standard Kit 1"
DrPc	PopRk	4810	MB_8Beat Basic	4/4	4	120	○		:
DrPc	PopRk	4811	MC_8Beat Basic	4/4	4	120	○		:
DrPc	PopRk	4812	FA_8Beat Basic	4/4	1	120	○		:
DrPc	PopRk	4813	FB_8Beat Basic	4/4	1	120	○		:
DrPc	PopRk	4814	FC_8Beat Basic	4/4	1	120	○		:
DrPc	PopRk	4815	BA_8Beat Basic	4/4	1	120	○		:
DrPc	PopRk	4816	MA_8Beat Soft	4/4	4	100	○		:
DrPc	PopRk	4817	MB_8Beat Soft	4/4	4	100	○		:
DrPc	PopRk	4818	MC_8Beat Soft	4/4	4	100	○		:
DrPc	PopRk	4819	FA_8Beat Soft	4/4	1	100	○		:
DrPc	PopRk	4820	FB_8Beat Soft	4/4	1	100	○		:
DrPc	PopRk	4821	FC_8Beat Soft	4/4	1	100	○		:
DrPc	PopRk	4822	BA_8Beat Soft	4/4	1	100	○		:
DrPc	PopRk	4823	MA_Soft Rock	4/4	4	120	○		"Dry Standard Kit"
DrPc	PopRk	4824	MB_Soft Rock	4/4	4	120	○		:
DrPc	PopRk	4825	MC_Soft Rock	4/4	4	120	○		:
DrPc	PopRk	4826	MD_Soft Rock	4/4	4	120	○		:
DrPc	PopRk	4827	IA_Soft Rock	4/4	1	120	○		:
DrPc	PopRk	4828	FA_Soft Rock	4/4	1	120	○		:
DrPc	PopRk	4829	FB_Soft Rock	4/4	1	120	○		:
DrPc	PopRk	4830	FC_Soft Rock	4/4	1	120	○		:
DrPc	PopRk	4831	MA_BritRockPop	4/4	4	123	○		"Power Standard Kit 1"
DrPc	PopRk	4832	MB_BritRockPop	4/4	4	123	○		:
DrPc	PopRk	4833	MC_BritRockPop	4/4	4	123	○		:
DrPc	PopRk	4834	FA_BritRockPop	4/4	1	123	○		:
DrPc	PopRk	4835	FB_BritRockPop	4/4	1	123	○		:
DrPc	PopRk	4836	FC_BritRockPop	4/4	1	123	○		:
DrPc	PopRk	4837	BA_BritRockPop	4/4	1	123	○		:
DrPc	PopRk	4838	EA_BritRockPop	4/4	6	123	○		:
DrPc	PopRk	4839	MA_80'sPopRock	4/4	4	111	○		"Rock Stereo Kit 2"
DrPc	PopRk	4840	MB_80'sPopRock	4/4	4	111	○		:
DrPc	PopRk	4841	MC_80'sPopRock	4/4	4	111	○		:
DrPc	PopRk	4842	FA_80'sPopRock	4/4	1	111	○		:
DrPc	PopRk	4843	FB_80'sPopRock	4/4	1	111	○		:
DrPc	PopRk	4844	FC_80'sPopRock	4/4	1	111	○		:
DrPc	PopRk	4845	BA_80'sPopRock	4/4	1	111	○		:
DrPc	PopRk	4846	EA_80'sPopRock	4/4	7	111	○		:
DrPc	PopRk	4847	MA_80'sSynthRock	4/4	4	96	○		"Modern Rock Kit"
DrPc	PopRk	4848	MB_80'sSynthRock	4/4	4	96	○		:
DrPc	PopRk	4849	MC_80'sSynthRock	4/4	8	96	○		:
DrPc	PopRk	4850	FA_80'sSynthRock	4/4	1	96	○		:
DrPc	PopRk	4851	FB_80'sSynthRock	4/4	1	96	○		:
DrPc	PopRk	4852	FC_80'sSynthRock	4/4	1	96	○		:
DrPc	PopRk	4853	BA_80'sSynthRock	4/4	1	96	○		:
DrPc	PopRk	4854	EA_80'sSynthRock	4/4	3	96	○		:
DrPc	PopRk	4855	MA_60sVintagePop	4/4	4	132	○		"Jazz Kit"
DrPc	PopRk	4856	MB_60sVintagePop	4/4	4	132	○		:
DrPc	PopRk	4857	MC_60sVintagePop	4/4	4	132	○		:
DrPc	PopRk	4858	FA_60sVintagePop	4/4	1	132	○		:
DrPc	PopRk	4859	FB_60sVintagePop	4/4	1	132	○		:
DrPc	PopRk	4860	FC_60sVintagePop	4/4	1	132	○		:
DrPc	PopRk	4861	BA_60sVintagePop	4/4	1	132	○		:
DrPc	PopRk	4862	EA_60sVintagePop	4/4	2	132	○		:
DrPc	PopRk	4863	MA_60sChartSwing	4/4	4	123	○		"Power Standard Kit 1"
DrPc	PopRk	4864	MB_60sChartSwing	4/4	4	123	○		:
DrPc	PopRk	4865	MC_60sChartSwing	4/4	4	123	○		:
DrPc	PopRk	4866	FA_60sChartSwing	4/4	1	123	○		:
DrPc	PopRk	4867	FB_60sChartSwing	4/4	1	123	○		:
DrPc	PopRk	4868	FC_60sChartSwing	4/4	1	123	○		:
DrPc	PopRk	4869	BA_60sChartSwing	4/4	1	123	○		:
DrPc	PopRk	4870	EA_60sChartSwing	4/4	4	123	○		:
DrPc	PopRk	4871	MA_16BeatBasic1	4/4	4	90	○		:
DrPc	PopRk	4872	MB_16BeatBasic1	4/4	4	90	○		:
DrPc	PopRk	4873	MC_16BeatBasic1	4/4	4	90	○		:
DrPc	PopRk	4874	FA_16BeatBasic1	4/4	1	90	○		:
DrPc	PopRk	4875	FB_16BeatBasic1	4/4	1	90	○		:
DrPc	PopRk	4876	FC_16BeatBasic1	4/4	1	90	○		:
DrPc	PopRk	4877	BA_16BeatBasic1	4/4	1	90	○		:
DrPc	PopRk	4878	MA_16BeatBasic2	4/4	4	77	○		:
DrPc	PopRk	4879	MB_16BeatBasic2	4/4	4	77	○		:
DrPc	PopRk	4880	MC_16BeatBasic2	4/4	4	77	○		:
DrPc	PopRk	4881	FA_16BeatBasic2	4/4	1	77	○		:
DrPc	PopRk	4882	FB_16BeatBasic2	4/4	1	77	○		:
DrPc	PopRk	4883	FC_16BeatBasic2	4/4	1	77	○		:
DrPc	PopRk	4884	BA_16BeatBasic2	4/4	1	77	○		:
DrPc	PopRk	4885	MA_16Beat Pop 1	4/4	4	103	○		:
DrPc	PopRk	4886	MB_16Beat Pop 1	4/4	4	103	○		:
DrPc	PopRk	4887	MC_16Beat Pop 1	4/4	4	103	○		:
DrPc	PopRk	4888	FA_16Beat Pop 1	4/4	1	103	○		:
DrPc	PopRk	4889	FB_16Beat Pop 1	4/4	1	103	○		:
DrPc	PopRk	4890	FC_16Beat Pop 1	4/4	1	103	○		:
DrPc	PopRk	4891	BA_16Beat Pop 1	4/4	1	103	○		:

Main Category	Sub Category	ARP No.	ARP Name	Time Signature	Length	Original Tempo	Accent	Random SFX	Voice Type
DrPc	PopRk	4892	MA_16Beat Pop 2	4/4	4	94	○		"Analog T8 Kit"
DrPc	PopRk	4893	MB_16Beat Pop 2	4/4	4	94	○		:
DrPc	PopRk	4894	MC_16Beat Pop 2	4/4	4	94	○		:
DrPc	PopRk	4895	FA_16Beat Pop 2	4/4	1	94	○		:
DrPc	PopRk	4896	FB_16Beat Pop 2	4/4	1	94	○		:
DrPc	PopRk	4897	FC_16Beat Pop 2	4/4	1	94	○		:
DrPc	PopRk	4898	BA_16Beat Pop 2	4/4	1	94	○		:
DrPc	PopRk	4899	MA_Piano Club	4/4	2	96	○		"Hyper Standard Kit"
DrPc	PopRk	4900	MB_Piano Club	4/4	2	96	○		:
DrPc	PopRk	4901	MC_Piano Club	4/4	2	96	○		:
DrPc	PopRk	4902	MD_Piano Club	4/4	2	96	○		:
DrPc	PopRk	4903	IA_Piano Club/a	4/4	2	96	○		:
DrPc	PopRk	4904	IA_Piano Club/b	4/4	2	96	○		:
DrPc	PopRk	4905	FA_Piano Club	4/4	1	96	○		:
DrPc	PopRk	4906	FB_Piano Club	4/4	1	96	○		:
DrPc	PopRk	4907	FC_Piano Club/a	4/4	2	96	○		:
DrPc	PopRk	4908	FC_Piano Club/b	4/4	1	96	○		:
DrPc	PopRk	4909	MA_Analog Pop	4/4	2	93	○		"Analog T8 Kit"
DrPc	PopRk	4910	MB_Analog Pop	4/4	2	93	○		:
DrPc	PopRk	4911	MC_Analog Pop	4/4	2	93	○		:
DrPc	PopRk	4912	MD_Analog Pop	4/4	4	93	○		:
DrPc	PopRk	4913	IA_Analog Pop	4/4	2	93	○		:
DrPc	PopRk	4914	FA_Analog Pop	4/4	1	93	○		:
DrPc	PopRk	4915	FB_Analog Pop	4/4	1	93	○		:
DrPc	PopRk	4916	FC_Analog Pop	4/4	2	93	○		:
DrPc	PopRk	4917	MA1_Psycho Beatz	4/4	4	94	○		"Psychedelic Kit"
DrPc	PopRk	4918	MA2_Psycho Beatz	4/4	4	94	○		:
DrPc	PopRk	4919	MA3_Psycho Beatz	4/4	1	94	○		:
DrPc	PopRk	4920	MB1_Psycho Beatz	4/4	4	94	○		:
DrPc	PopRk	4921	MB2_Psycho Beatz	4/4	4	94	○		:
DrPc	PopRk	4922	MB3_Psycho Beatz	4/4	1	94	○		:
DrPc	PopRk	4923	MB4_Psycho Beatz	4/4	1	94	○		:
DrPc	PopRk	4924	MC1_Psycho Beatz	4/4	2	94	○		:
DrPc	PopRk	4925	MC2_Psycho Beatz	4/4	2	94	○		:
DrPc	PopRk	4926	MC3_Psycho Beatz	4/4	4	94	○		:
DrPc	PopRk	4927	MC4_Psycho Beatz	4/4	4	94	○		:
DrPc	PopRk	4928	MD1_Psycho Beatz	4/4	4	94	○		:
DrPc	PopRk	4929	MD2_Psycho Beatz	4/4	4	94	○		:
DrPc	PopRk	4930	MD3_Psycho Beatz	4/4	4	94	○		:
DrPc	PopRk	4931	MD4_Psycho Beatz	4/4	4	94	○		:
DrPc	PopRk	4932	ME1_Psycho Beatz	4/4	4	94	○		:
DrPc	PopRk	4933	ME2_Psycho Beatz	4/4	4	94	○		:
DrPc	PopRk	4934	ME3_Psycho Beatz	4/4	4	94	○		:
DrPc	PopRk	4935	ME4_Psycho Beatz	4/4	4	94	○		:
DrPc	PopRk	4936	MA_8Z RX11	4/4	1	140	○		"8Z RX11"
DrPc	PopRk	4937	MB_8Z RX11	4/4	1	140	○		:
DrPc	PopRk	4938	MC_8Z RX11	4/4	2	140	○		:
DrPc	PopRk	4939	FA_8Z RX11	4/4	1	140	○		:
DrPc	PopRk	4940	FB_8Z RX11	4/4	1	140	○		:
DrPc	PopRk	4941	EA_8Z RX11	4/4	3	140	○		:
DrPc	PopRk	4942	MA_6/8 Pop	4/4	4	100	○		"Power Standard Kit 1"
DrPc	PopRk	4943	MB_6/8 Pop	4/4	4	100	○		:
DrPc	PopRk	4944	MC_6/8 Pop	4/4	4	100	○		:
DrPc	PopRk	4945	FA_6/8 Pop	4/4	1	100	○		:
DrPc	PopRk	4946	FB_6/8 Pop	4/4	1	100	○		:
DrPc	PopRk	4947	FC_6/8 Pop	4/4	1	100	○		:
DrPc	PopRk	4948	BA_6/8 Pop	4/4	1	100	○		:
DrPc	PopRk	4949	EA_6/8Pop	4/4	3	123	○		:
DrPc	Ballad	4950	MA_GuitarBallad	4/4	8	94	○		:
DrPc	Ballad	4951	MB_GuitarBallad	4/4	8	94	○		:
DrPc	Ballad	4952	MC_GuitarBallad	4/4	8	94	○		:
DrPc	Ballad	4953	FA_GuitarBallad	4/4	1	94	○		:
DrPc	Ballad	4954	FB_GuitarBallad	4/4	1	94	○		:
DrPc	Ballad	4955	FC_GuitarBallad	4/4	1	94	○		:
DrPc	Ballad	4956	BA_GuitarBallad	4/4	1	94	○		:
DrPc	Ballad	4957	EA_GuitarBallad	4/4	4	94	○		:
DrPc	Ballad	4958	EB_GuitarBallad	4/4	4	94	○		:
DrPc	Ballad	4959	MA_Unplugged 1	4/4	4	120	○		:
DrPc	Ballad	4960	MB_Unplugged 1	4/4	4	120	○		:
DrPc	Ballad	4961	MC_Unplugged 1	4/4	4	120	○		:
DrPc	Ballad	4962	FA_Unplugged 1	4/4	1	120	○		:
DrPc	Ballad	4963	FB_Unplugged 1	4/4	1	120	○		:
DrPc	Ballad	4964	FC_Unplugged 1	4/4	1	120	○		:
DrPc	Ballad	4965	BA_Unplugged 1	4/4					

Arpeggio Type List

Main Category	Sub Category	ARP No.	ARP Name	Time Signature	Length	Original Tempo	Accent	Random SFX	Voice Type
DrPc	Balad	4975	MC2_Unplugged 2	4/4	8	120	○		*Power Standard Kit 1*
DrPc	Balad	4976	FA2_Unplugged 2	4/4	1	120	○		:
DrPc	Balad	4977	FB2_Unplugged 2	4/4	1	120	○		:
DrPc	Balad	4978	FC2_Unplugged 2	4/4	1	120	○		:
DrPc	Balad	4979	BA2_Unplugged 2	4/4	1	120	○		:
DrPc	Balad	4980	EA1_Unplugged 2	4/4	5	120	○		:
DrPc	Balad	4981	EB1_Unplugged 2	4/4	4	120	○		:
DrPc	Balad	4982	MA_Unplugged 3	4/4	4	113	○		*Power Standard Kit 2*
DrPc	Balad	4983	MB_Unplugged 3	4/4	4	113	○		:
DrPc	Balad	4984	MC_Unplugged 3	4/4	4	113	○		:
DrPc	Balad	4985	FA_Unplugged 3	4/4	1	113	○		:
DrPc	Balad	4986	FB_Unplugged 3	4/4	1	113	○		:
DrPc	Balad	4987	FC_Unplugged 3	4/4	1	113	○		:
DrPc	Balad	4988	BA_Unplugged 3	4/4	1	113	○		:
DrPc	Balad	4989	MA_Unplugged 4	4/4	4	120	○		*Dry Standard Kit*
DrPc	Balad	4990	MB_Unplugged 4	4/4	4	120	○		:
DrPc	Balad	4991	MC_Unplugged 4	4/4	4	120	○		:
DrPc	Balad	4992	MD_Unplugged 4	4/4	4	120	○		:
DrPc	Balad	4993	IA_Unplugged 4	4/4	1	120	○		:
DrPc	Balad	4994	FA_Unplugged 4	4/4	1	120	○		:
DrPc	Balad	4995	FB_Unplugged 4	4/4	1	120	○		:
DrPc	Balad	4996	FC_Unplugged 4	4/4	1	120	○		:
DrPc	Balad	4997	EA_Unplugged 4	4/4	4	120	○		:
DrPc	Balad	4998	EB_Unplugged 4	4/4	3	120	○		:
DrPc	Balad	4999	MA_8Beat Ballad	4/4	4	101	○		*Brush Kit*
DrPc	Balad	5000	MB_8Beat Ballad	4/4	4	101	○		:
DrPc	Balad	5001	MC_8Beat Ballad	4/4	4	101	○		:
DrPc	Balad	5002	FA_8Beat Ballad	4/4	1	101	○		:
DrPc	Balad	5003	FB_8Beat Ballad	4/4	1	101	○		:
DrPc	Balad	5004	FC_8Beat Ballad	4/4	1	101	○		:
DrPc	Balad	5005	BA_8Beat Ballad	4/4	1	101	○		:
DrPc	Balad	5006	EA_8Beat Ballad	4/4	5	101	○		:
DrPc	Balad	5007	EB_8Beat Ballad	4/4	5	101	○		:
DrPc	Balad	5008	MA_EP Ballad	4/4	2	60	○		*Power Standard Kit 2*
DrPc	Balad	5009	MB_EP Ballad	4/4	2	60	○		:
DrPc	Balad	5010	MC_EP Ballad	4/4	2	60	○		:
DrPc	Balad	5011	FA_EP Ballad	4/4	1	60	○		:
DrPc	Balad	5012	FB_EP Ballad	4/4	1	60	○		:
DrPc	Balad	5013	FC_EP Ballad	4/4	1	60	○		:
DrPc	Balad	5014	BA_EP Ballad	4/4	1	60	○		:
DrPc	Balad	5015	EA_EP Ballad	4/4	4	60	○		:
DrPc	Balad	5016	EB_EP Ballad	4/4	4	60	○		:
DrPc	Balad	5017	MA_Ballad 1	4/4	2	72	○		*Hyper Standard Kit*
DrPc	Balad	5018	MB_Ballad 1	4/4	2	72	○		:
DrPc	Balad	5019	MA_Ballad 2	4/4	2	72	○		:
DrPc	Balad	5020	MB_Ballad 2	4/4	2	72	○		:
DrPc	Balad	5021	MA_Ballad 3	4/4	2	72	○		:
DrPc	Balad	5022	MB_Ballad 3	4/4	1	72	○		:
DrPc	Balad	5023	MA_8Beat Slow	4/4	4	78	○		*Power Standard Kit 2*
DrPc	Balad	5024	MB_8Beat Slow	4/4	4	78	○		:
DrPc	Balad	5025	MC_8Beat Slow	4/4	4	78	○		:
DrPc	Balad	5026	FA_8Beat Slow	4/4	1	78	○		:
DrPc	Balad	5027	FB_8Beat Slow	4/4	1	78	○		:
DrPc	Balad	5028	FC_8Beat Slow	4/4	1	78	○		:
DrPc	Balad	5029	BA_8Beat Slow	4/4	1	78	○		:
DrPc	Balad	5030	MA_Slowfeel	4/4	1	74	○		*Hyper Standard Kit*
DrPc	Balad	5031	MB_Slowfeel	4/4	1	74	○		:
DrPc	Balad	5032	MC_Slowfeel	4/4	1	74	○		:
DrPc	Balad	5033	MD_Slowfeel	4/4	1	74	○		:
DrPc	Balad	5034	IA_Slowfeel	4/4	2	74	○		:
DrPc	Balad	5035	FA_Slowfeel	4/4	1	74	○		:
DrPc	Balad	5036	FB_Slowfeel	4/4	1	74	○		:
DrPc	Balad	5037	FC_Slowfeel	4/4	2	74	○		:
DrPc	Balad	5038	MA_16Bt Ballad1	4/4	4	75	○		*Power Standard Kit 2*
DrPc	Balad	5039	MB_16Bt Ballad1	4/4	4	75	○		:
DrPc	Balad	5040	MC_16Bt Ballad1	4/4	4	75	○		:
DrPc	Balad	5041	FA_16Bt Ballad1	4/4	1	75	○		:
DrPc	Balad	5042	FB_16Bt Ballad1	4/4	1	75	○		:
DrPc	Balad	5043	FC_16Bt Ballad1	4/4	1	75	○		:
DrPc	Balad	5044	BA_16Bt Ballad1	4/4	1	75	○		:
DrPc	Balad	5045	MA_16Bt Ballad2	4/4	2	64	○		*Power Standard Kit 1*
DrPc	Balad	5046	MB_16Bt Ballad2	4/4	2	64	○		:
DrPc	Balad	5047	MC_16Bt Ballad2	4/4	2	64	○		:
DrPc	Balad	5048	MD_16Bt Ballad2	4/4	2	64	○		:
DrPc	Balad	5049	ME_16Bt Ballad2	4/4	2	64	○		:
DrPc	Balad	5050	MF_16Bt Ballad2	4/4	2	64	○		:
DrPc	Balad	5051	BA_16Bt Ballad2	4/4	1	64	○		:
DrPc	Balad	5052	MA_ChillKitPop1	4/4	2	85	○		*Chill Out Kit*
DrPc	Balad	5053	MA_ChillKitPop2	4/4	2	85	○		:
DrPc	Balad	5054	MA_ChillKitPop3	4/4	2	85	○		:
DrPc	Balad	5055	MA_ChillKitPop4	4/4	2	85	○		:
DrPc	Balad	5056	MA_ChillKitPop5	4/4	2	85	○		:
DrPc	Balad	5057	MA_ChillKitBallad1	4/4	2	90	○		:

Main Category	Sub Category	ARP No.	ARP Name	Time Signature	Length	Original Tempo	Accent	Random SFX	Voice Type
DrPc	Balad	5058	MB_ChillKitBallad1	4/4	2	90	○		*Chill Out Kit*
DrPc	Balad	5059	MA_ChillKitBallad2	4/4	2	90	○		:
DrPc	Balad	5060	MB_ChillKitBallad2	4/4	2	90	○		:
DrPc	Balad	5061	MA_ChillKitBallad3	4/4	2	90	○		:
DrPc	Balad	5062	MA_ChillKitBallad4	4/4	2	90	○		:
DrPc	Balad	5063	MA_ChillKitBallad5	4/4	2	90	○		:
DrPc	Balad	5064	MA_Nu Jazzy	4/4	2	61	○		*Nu Jazzy Kit*
DrPc	Balad	5065	MB_Nu Jazzy	4/4	2	61	○		:
DrPc	Balad	5066	MC_Nu Jazzy	4/4	2	61	○		:
DrPc	Balad	5067	FA_Nu Jazzy	4/4	1	61	○		:
DrPc	Balad	5068	EA_Nu Jazzy	4/4	4	61	○		:
DrPc	Balad	5069	MA_6/8 Ballad	6/8	4	87	○		*Power Standard Kit 2*
DrPc	Balad	5070	MB_6/8 Ballad	6/8	4	87	○		:
DrPc	Balad	5071	MC_6/8 Ballad	6/8	4	87	○		:
DrPc	Balad	5072	FA_6/8 Ballad	6/8	1	87	○		:
DrPc	Balad	5073	FB_6/8 Ballad	6/8	1	87	○		:
DrPc	Balad	5074	FC_6/8 Ballad	6/8	1	87	○		:
DrPc	Balad	5075	BA_6/8 Ballad	6/8	1	87	○		:
DrPc	Balad	5076	EA_6/8 Ballad	6/8	6	87	○		:
DrPc	Balad	5077	EB_6/8 Ballad	6/8	6	87	○		:
DrPc	HipHp	5078	MA_2BZ4U	4/4	4	75	○		*Nu Hip Hop Kit 2*
DrPc	HipHp	5079	MB_2BZ4U	4/4	4	75	○		:
DrPc	HipHp	5080	MC_2BZ4U	4/4	4	75	○		:
DrPc	HipHp	5081	MD_2BZ4U	4/4	4	75	○		:
DrPc	HipHp	5082	MA_Bklyn	4/4	4	89	○		*Hip Hop Kit 1*
DrPc	HipHp	5083	MB_Bklyn	4/4	4	89	○		:
DrPc	HipHp	5084	MC_Bklyn	4/4	4	89	○		:
DrPc	HipHp	5085	MD_Bklyn	4/4	4	89	○		:
DrPc	HipHp	5086	ME_Bklyn	4/4	4	89	○		:
DrPc	HipHp	5087	MF_Bklyn	4/4	4	89	○		:
DrPc	HipHp	5088	MA_DirtySynth	4/4	4	85	○		*Analog T8 Kit*
DrPc	HipHp	5089	MB_DirtySynth	4/4	4	85	○		:
DrPc	HipHp	5090	MC_DirtySynth	4/4	4	85	○		:
DrPc	HipHp	5091	MA_PepRally	4/4	2	75	○		*Nu Hip Hop Kit 1*
DrPc	HipHp	5092	MB_PepRally	4/4	2	75	○		:
DrPc	HipHp	5093	MC_PepRally	4/4	2	75	○		:
DrPc	HipHp	5094	MD_PepRally	4/4	2	75	○		:
DrPc	HipHp	5095	ME_PepRally	4/4	2	75	○		:
DrPc	HipHp	5096	MA_HipHopEpic/1	4/4	2	85	○		*Hip Hop Kit 4*
DrPc	HipHp	5097	MA_HipHopEpic/2	4/4	2	85	○		:
DrPc	HipHp	5098	MA_HipHopEpic/3	4/4	2	85	○		:
DrPc	HipHp	5099	MB_HipHopEpic/1	4/4	2	85	○		:
DrPc	HipHp	5100	MB_HipHopEpic/2	4/4	2	85	○		:
DrPc	HipHp	5101	MB_HipHopEpic/3	4/4	2	85	○		:
DrPc	HipHp	5102	MC_HipHopEpic/1	4/4	2	85	○		:
DrPc	HipHp	5103	MC_HipHopEpic/2	4/4	2	85	○		:
DrPc	HipHp	5104	MC_HipHopEpic/3	4/4	2	85	○		:
DrPc	HipHp	5105	MA1_New Hip Hop	4/4	2	85	○		*Power Standard Kit 1*
DrPc	HipHp	5106	MB1_New Hip Hop	4/4	2	85	○		:
DrPc	HipHp	5107	MC1_New Hip Hop	4/4	2	85	○		:
DrPc	HipHp	5108	FA1_New Hip Hop	4/4	1	85	○		:
DrPc	HipHp	5109	FB1_New Hip Hop	4/4	1	85	○		:
DrPc	HipHp	5110	FC1_New Hip Hop	4/4	1	85	○		:
DrPc	HipHp	5111	BA1_New Hip Hop	4/4	1	85	○		:
DrPc	HipHp	5112	EA1_New Hip Hop	4/4	3	85	○		:
DrPc	HipHp	5113	EB1_New Hip Hop	4/4	3	85	○		:
DrPc	HipHp	5114	MA2_New Hip Hop	4/4	2	85	○		*Hip Hop Kit 2*
DrPc	HipHp	5115	MB2_New Hip Hop	4/4	2	85	○		:
DrPc	HipHp	5116	MC2_New Hip Hop	4/4	2	85	○		:
DrPc	HipHp	5117	FA2_New Hip Hop	4/4	1	85	○		:
DrPc	HipHp	5118	FB2_New Hip Hop	4/4	1	85	○		:
DrPc	HipHp	5119	FC2_New Hip Hop	4/4	1	85	○		:
DrPc	HipHp	5120	BA2_New Hip Hop	4/4	1	85	○		:
DrPc	HipHp	5121	EA2_New Hip Hop	4/4	3	85	○		:
DrPc	HipHp	5122	EB2_New Hip Hop	4/4	3	85	○		:
DrPc	HipHp	5123	MA_East Coast	4/4	2	103	○		*Hip Hop Kit 1*
DrPc	HipHp	5124	MB_East Coast	4/4	2	103	○		:
DrPc	HipHp	5125	MC_East Coast	4/4	2	103	○		:
DrPc	HipHp	5126	MD_East Coast	4/4	2	103	○		:
DrPc	HipHp	5127	FA_East Coast	4/4	1	103	○		:
DrPc	HipHp	5128	FB_East Coast	4/4	1	103	○		:
DrPc	HipHp	5129	FC_East Coast	4/4	1	103	○		:
DrPc	HipHp	5130	FD_East Coast	4/4	1	103	○		:
DrPc	HipHp	5131	MA1_West Coast	4/4	2	97	○		*Hip Hop Kit 2*
DrPc	HipHp	5132	MB1_West Coast	4/4	2	97	○		:
DrPc	HipHp	5133	MC1_West Coast	4/4	2	97	○		

Arpeggio Type List

Main Category	Sub Category	ARP No.	ARP Name	Time Signature	Length	Original Tempo	Accent	Random SFX	Voice Type
DrPc	HipHp	5141	MC2_West Coast	4/4	2	97	○		"Hip Hop Kit 1"
DrPc	HipHp	5142	MD2_West Coast	4/4	2	97	○		:
DrPc	HipHp	5143	FA2_West Coast	4/4	1	97	○		:
DrPc	HipHp	5144	FB2_West Coast	4/4	1	97	○		:
DrPc	HipHp	5145	FC2_West Coast	4/4	1	97	○		:
DrPc	HipHp	5146	FD2_West Coast	4/4	1	97	○		:
DrPc	HipHp	5147	MA1_South Rap 1	4/4	4	98	○		"Belly Dance Kit"
DrPc	HipHp	5148	MB1_South Rap 1	4/4	4	98	○		:
DrPc	HipHp	5149	MC1_South Rap 1	4/4	4	98	○		:
DrPc	HipHp	5150	MD1_South Rap 1	4/4	4	98	○		:
DrPc	HipHp	5151	FA1_South Rap 1	4/4	1	98	○		:
DrPc	HipHp	5152	FB1_South Rap 1	4/4	1	98	○		:
DrPc	HipHp	5153	FC1_South Rap 1	4/4	1	98	○		:
DrPc	HipHp	5154	FD1_South Rap 1	4/4	1	98	○		:
DrPc	HipHp	5155	MA2_South Rap 1	4/4	4	98	○		"Hip Hop Kit 1"
DrPc	HipHp	5156	MB2_South Rap 1	4/4	4	98	○		:
DrPc	HipHp	5157	MC2_South Rap 1	4/4	4	98	○		:
DrPc	HipHp	5158	MD2_South Rap 1	4/4	4	98	○		:
DrPc	HipHp	5159	FA2_South Rap 1	4/4	1	98	○		:
DrPc	HipHp	5160	FB2_South Rap 1	4/4	1	98	○		:
DrPc	HipHp	5161	FC2_South Rap 1	4/4	1	98	○		:
DrPc	HipHp	5162	FD2_South Rap 1	4/4	1	98	○		:
DrPc	HipHp	5163	MB1_South Rap 2	4/4	2	90	○		"Hip Hop Kit 2"
DrPc	HipHp	5164	MC1_South Rap 2	4/4	2	90	○		:
DrPc	HipHp	5165	MD1_South Rap 2	4/4	2	90	○		:
DrPc	HipHp	5166	FA1_South Rap 2	4/4	1	90	○		:
DrPc	HipHp	5167	FB1_South Rap 2	4/4	1	90	○		:
DrPc	HipHp	5168	FC1_South Rap 2	4/4	1	90	○		:
DrPc	HipHp	5169	FD1_South Rap 2	4/4	1	90	○		:
DrPc	HipHp	5170	MA2_South Rap 2	4/4	2	90	○		"Hip Hop Kit 1"
DrPc	HipHp	5171	MB2_South Rap 2	4/4	2	90	○		:
DrPc	HipHp	5172	MC2_South Rap 2	4/4	2	90	○		:
DrPc	HipHp	5173	MD2_South Rap 2	4/4	2	90	○		:
DrPc	HipHp	5174	FA2_South Rap 2	4/4	1	90	○		:
DrPc	HipHp	5175	FB2_South Rap 2	4/4	1	90	○		:
DrPc	HipHp	5176	FC2_South Rap 2	4/4	1	90	○		:
DrPc	HipHp	5177	FD2_South Rap 2	4/4	1	90	○		:
DrPc	HipHp	5178	MA_Hip Hop 1	4/4	2	105	○		"Hip Hop Kit 3"
DrPc	HipHp	5179	MB_Hip Hop 1	4/4	2	105	○		:
DrPc	HipHp	5180	MC_Hip Hop 1	4/4	2	105	○		:
DrPc	HipHp	5181	MD_Hip Hop 1	4/4	2	105	○		:
DrPc	HipHp	5182	IA_Hip Hop 1	4/4	1	105	○		:
DrPc	HipHp	5183	FA_Hip Hop 1	4/4	1	105	○		:
DrPc	HipHp	5184	FB_Hip Hop 1	4/4	1	105	○		:
DrPc	HipHp	5185	FC_Hip Hop 1	4/4	2	105	○		:
DrPc	HipHp	5186	MA_Hip Hop 2	4/4	2	104	○		:
DrPc	HipHp	5187	MB_Hip Hop 2	4/4	2	104	○		:
DrPc	HipHp	5188	MC_Hip Hop 2	4/4	2	104	○		:
DrPc	HipHp	5189	MD_Hip Hop 2	4/4	2	104	○		:
DrPc	HipHp	5190	IA_Hip Hop 2	4/4	1	104	○		:
DrPc	HipHp	5191	FA_Hip Hop 2	4/4	1	104	○		:
DrPc	HipHp	5192	FB_Hip Hop 2	4/4	1	104	○		:
DrPc	HipHp	5193	FC_Hip Hop 2	4/4	2	104	○		:
DrPc	HipHp	5194	MA_Hip Hop 3	4/4	2	94	○		"Break Kit"
DrPc	HipHp	5195	MB_Hip Hop 3	4/4	2	94	○		:
DrPc	HipHp	5196	MC_Hip Hop 3	4/4	2	94	○		:
DrPc	HipHp	5197	MD_Hip Hop 3	4/4	2	94	○		:
DrPc	HipHp	5198	IA_Hip Hop 3	4/4	2	94	○		:
DrPc	HipHp	5199	FA_Hip Hop 3	4/4	1	94	○		:
DrPc	HipHp	5200	FB_Hip Hop 3	4/4	1	94	○		:
DrPc	HipHp	5201	FC_Hip Hop 3	4/4	2	94	○		:
DrPc	HipHp	5202	MA_Hip Hop 4	4/4	2	96	○		"Hip Hop Kit 1"
DrPc	HipHp	5203	MA1_Hip Hop 5	4/4	2	103	○		:
DrPc	HipHp	5204	MB1_Hip Hop 5	4/4	4	103	○		:
DrPc	HipHp	5205	MC1_Hip Hop 5	4/4	2	103	○		:
DrPc	HipHp	5206	MD1_Hip Hop 5	4/4	2	103	○		:
DrPc	HipHp	5207	FA1_Hip Hop 5	4/4	1	103	○		:
DrPc	HipHp	5208	FB1_Hip Hop 5	4/4	1	103	○		:
DrPc	HipHp	5209	FC1_Hip Hop 5	4/4	1	103	○		:
DrPc	HipHp	5210	FD1_Hip Hop 5	4/4	1	103	○		:
DrPc	HipHp	5211	MA2_Hip Hop 5	4/4	2	103	○		"Nu Hip Hop Kit 2"
DrPc	HipHp	5212	MB2_Hip Hop 5	4/4	4	103	○		:
DrPc	HipHp	5213	MC2_Hip Hop 5	4/4	2	103	○		:
DrPc	HipHp	5214	MD2_Hip Hop 5	4/4	2	103	○		:
DrPc	HipHp	5215	FA2_Hip Hop 5	4/4	1	103	○		:
DrPc	HipHp	5216	FB2_Hip Hop 5	4/4	1	103	○		:
DrPc	HipHp	5217	FC2_Hip Hop 5	4/4	1	103	○		:
DrPc	HipHp	5218	FD2_Hip Hop 5	4/4	1	103	○		:
DrPc	HipHp	5219	MA_Hip Hop 6	4/4	4	96	○		"Hip Hop Kit 1"
DrPc	HipHp	5220	MB_Hip Hop 6	4/4	4	96	○		:
DrPc	HipHp	5221	MC_Hip Hop 6	4/4	4	96	○		:
DrPc	HipHp	5222	FA_Hip Hop 6	4/4	1	96	○		:
DrPc	HipHp	5223	FB_Hip Hop 6	4/4	1	96	○		:

Main Category	Sub Category	ARP No.	ARP Name	Time Signature	Length	Original Tempo	Accent	Random SFX	Voice Type
DrPc	HipHp	5224	FC_Hip Hop 6	4/4	1	96	○		"Hip Hop Kit 1"
DrPc	HipHp	5225	BA_Hip Hop 6	4/4	1	96	○		:
DrPc	HipHp	5226	MA1_Hip Break	4/4	4	98	○		:
DrPc	HipHp	5227	MB1_Hip Break	4/4	4	98	○		:
DrPc	HipHp	5228	MC1_Hip Break	4/4	4	98	○		:
DrPc	HipHp	5229	FA1_Hip Break	4/4	1	98	○		:
DrPc	HipHp	5230	FB1_Hip Break	4/4	1	98	○		:
DrPc	HipHp	5231	FC1_Hip Break	4/4	1	98	○		:
DrPc	HipHp	5232	BA1_Hip Break	4/4	1	98	○		:
DrPc	HipHp	5233	MA2_Hip Break	4/4	4	98	○		"Break Kit"
DrPc	HipHp	5234	MB2_Hip Break	4/4	4	98	○		:
DrPc	HipHp	5235	MC2_Hip Break	4/4	4	98	○		:
DrPc	HipHp	5236	FA2_Hip Break	4/4	1	98	○		:
DrPc	HipHp	5237	FB2_Hip Break	4/4	1	98	○		:
DrPc	HipHp	5238	FC2_Hip Break	4/4	1	98	○		:
DrPc	HipHp	5239	BA2_Hip Break	4/4	1	98	○		:
DrPc	HipHp	5240	MA_Hip Rock 1	4/4	4	90	○		"Rock Stereo Kit 2"
DrPc	HipHp	5241	MB_Hip Rock 1	4/4	4	90	○		:
DrPc	HipHp	5242	MC_Hip Rock 1	4/4	4	90	○		:
DrPc	HipHp	5243	FA_Hip Rock 1	4/4	1	90	○		:
DrPc	HipHp	5244	FB_Hip Rock 1	4/4	1	90	○		:
DrPc	HipHp	5245	FC_Hip Rock 1	4/4	1	90	○		:
DrPc	HipHp	5246	BA_Hip Rock 1	4/4	1	90	○		:
DrPc	HipHp	5247	MA_Hip Rock 2	4/4	4	132	○		"House Kit 2"
DrPc	HipHp	5248	MB_Hip Rock 2	4/4	4	132	○		:
DrPc	HipHp	5249	MC_Hip Rock 2	4/4	4	132	○		:
DrPc	HipHp	5250	FA_Hip Rock 2	4/4	1	132	○		:
DrPc	HipHp	5251	FB_Hip Rock 2	4/4	1	132	○		:
DrPc	HipHp	5252	FC_Hip Rock 2	4/4	1	132	○		:
DrPc	HipHp	5253	BA_Hip Rock 2	4/4	1	132	○		:
DrPc	HipHp	5254	MA1_Hip Reggae	4/4	4	92	○		"House Kit 1"
DrPc	HipHp	5255	MB1_Hip Reggae	4/4	4	92	○		:
DrPc	HipHp	5256	MC1_Hip Reggae	4/4	4	92	○		:
DrPc	HipHp	5257	FA1_Hip Reggae	4/4	1	92	○		:
DrPc	HipHp	5258	FB1_Hip Reggae	4/4	1	92	○		:
DrPc	HipHp	5259	FC1_Hip Reggae	4/4	1	92	○		:
DrPc	HipHp	5260	BA1_Hip Reggae	4/4	1	92	○		:
DrPc	HipHp	5261	MA2_Hip Reggae	4/4	4	92	○		"Latin Percussion Kit"
DrPc	HipHp	5262	MB2_Hip Reggae	4/4	4	92	○		:
DrPc	HipHp	5263	MC2_Hip Reggae	4/4	4	92	○		:
DrPc	HipHp	5264	FA2_Hip Reggae	4/4	1	92	○		:
DrPc	HipHp	5265	FB2_Hip Reggae	4/4	1	92	○		:
DrPc	HipHp	5266	FC2_Hip Reggae	4/4	1	92	○		:
DrPc	HipHp	5267	BA2_Hip Reggae	4/4	1	92	○		:
DrPc	HipHp	5268	MA1_Regeton	4/4	4	98	○		"Hip Hop Kit 1"
DrPc	HipHp	5269	MB1_Regeton	4/4	4	98	○		:
DrPc	HipHp	5270	MC1_Regeton	4/4	4	98	○		:
DrPc	HipHp	5271	FA1_Regeton	4/4	1	98	○		:
DrPc	HipHp	5272	FB1_Regeton	4/4	1	98	○		:
DrPc	HipHp	5273	FC1_Regeton	4/4	1	98	○		:
DrPc	HipHp	5274	BA1_Regeton	4/4	1	98	○		:
DrPc	HipHp	5275	MA2_Regeton	4/4	4	98	○		"Percussion Kit"
DrPc	HipHp	5276	MB2_Regeton	4/4	4	98	○		:
DrPc	HipHp	5277	MC2_Regeton	4/4	4	98	○		:
DrPc	HipHp	5278	FA2_Regeton	4/4	1	98	○		:
DrPc	HipHp	5279	FB2_Regeton	4/4	1	98	○		:
DrPc	HipHp	5280	FC2_Regeton	4/4	1	98	○		:
DrPc	HipHp	5281	BA2_Regeton	4/4	1	98	○		:
DrPc	HipHp	5282	MA_Dancehall	4/4	4	103	○		"Break Kit"
DrPc	HipHp	5283	MB_Dancehall	4/4	4	103	○		:
DrPc	HipHp	5284	MD_Dancehall	4/4	4	103	○		:
DrPc	HipHp	5285	FA_Dancehall	4/4	1	103	○		:
DrPc	HipHp	5286	FB_Dancehall	4/4	1	103	○		:
DrPc	HipHp	5287	FD_Dancehall	4/4	1	103	○		:
DrPc	HipHp	5288	BA_Dancehall	4/4	1	103	○		:
DrPc	HipHp	5289	EA_Dancehall	4/4	3	103	○		:
DrPc	HipHp	5290	MA_Hip Ethnic 1	4/4	2	94	○		"Hip Hop Kit 1"
DrPc	HipHp	5291	MB_Hip Ethnic 1	4/4	2	94	○		:
DrPc	HipHp	5292	MC_Hip Ethnic 1	4/4	2	94	○		:
DrPc	HipHp	5293	MD_Hip Ethnic 1	4/4	2	94	○		:
DrPc	HipHp	5294	ME_Hip Ethnic 1	4/4	2	94	○		:
DrPc	HipHp	5295	MF_Hip Ethnic 1	4/4	2	94	○		:
DrPc	HipHp	5296	BA_Hip Ethnic 1	4/4	1	94	○		:
DrPc	HipHp	5297	MA_Hip Ethnic 2	4/4	2	110	○		:
DrPc	HipHp	5298	MB_Hip Ethnic 2	4/4	2	110	○		:
DrPc	HipHp	5299	MC_Hip Ethnic 2	4/4	2	110	○		

Arpeggio Type List

Main Category	Sub Category	ARP No.	ARP Name	Time Signature	Length	Original Tempo	Accent	Random SFX	Voice Type
DrPc	HipHp	5307	MD_ClassicHipHop	4/4	2	90	○		"Hip Hop Kit 3"
DrPc	HipHp	5308	IA_ClassicHipHop/1a	4/4	2	90	○		:
DrPc	HipHp	5309	IA_ClassicHipHop/1b	4/4	1	90	○		:
DrPc	HipHp	5310	FA_ClassicHipHop	4/4	1	90	○		:
DrPc	HipHp	5311	FB_ClassicHipHop	4/4	1	90	○		:
DrPc	HipHp	5312	IA_ClassicHipHop/2	4/4	4	90	○		:
DrPc	HipHp	5313	MA_i-Hop	4/4	4	98	○		:
DrPc	HipHp	5314	MB_i-Hop	4/4	4	98	○		:
DrPc	HipHp	5315	MC_i-Hop	4/4	4	98	○		:
DrPc	HipHp	5316	MD_i-Hop	4/4	1	98	○		:
DrPc	HipHp	5317	MA_Gangsta	4/4	2	98	○		"Hip Hop Kit 4"
DrPc	HipHp	5318	MB_Gangsta	4/4	4	98	○		:
DrPc	HipHp	5319	MC_Gangsta	4/4	4	98	○		:
DrPc	HipHp	5320	MD_Gangsta	4/4	2	98	○		:
DrPc	HipHp	5321	MA_Jazz Hop	4/4	2	106	○		"Hip Hop Kit 2"
DrPc	HipHp	5322	MA_HipHop Loop1	4/4	4	97	○		"Nu Hip Hop Kit 1"
DrPc	HipHp	5323	MA_HipHop Loop2	4/4	4	81	○		:
DrPc	HipHp	5324	MA_HipHop Loop3	4/4	4	96	○		:
DrPc	HipHp	5325	MA_HipHop Loop4	4/4	4	93	○		:
DrPc	HipHp	5326	MA_HipHop Loop5	4/4	4	94	○		:
DrPc	HipHp	5327	MA_HipHop Loop6	4/4	4	95	○		:
DrPc	HipHp	5328	MA_HipHop Loop7	4/4	4	100	○		:
DrPc	HipHp	5329	MA_HipHop Loop8	4/4	4	87	○		:
DrPc	HipHp	5330	MA_HipHop Loop9	4/4	4	97	○		:
DrPc	HipHp	5331	MA_HipHopLoop10	4/4	4	95	○		:
DrPc	HipHp	5332	MA_HipHopLoop11	4/4	4	96	○		:
DrPc	HipHp	5333	MA_HipHopLoop12	4/4	2	100	○		:
DrPc	HipHp	5334	MA_HipHopLoop13	4/4	2	100	○		:
DrPc	HipHp	5335	MA_HipHopLoop14	4/4	1	81	○		:
DrPc	HipHp	5336	MA_HipHopLoop15	4/4	1	97	○		:
DrPc	HipHp	5337	MA_HipHopLoop16	4/4	2	100	○		:
DrPc	HipHp	5338	MA_HipHopLoop17	4/4	2	75	○		:
DrPc	HipHp	5339	MA_HipHopLoop18	4/4	2	96	○		"Illest Hip Hop Kit"
DrPc	HipHp	5340	MA_HipHopLoop19	4/4	2	88	○		:
DrPc	HipHp	5341	MA_HipHopLoop20	4/4	3	96	○		:
DrPc	HipHp	5342	MA_HipHopLoop21	4/4	2	93	○		:
DrPc	HipHp	5343	MA_HipHopLoop22	4/4	2	80	○		:
DrPc	HipHp	5344	MA_HipHopLoop23	4/4	4	98	○		:
DrPc	HipHp	5345	MA_HipHopLoop24	4/4	2	92	○		:
DrPc	HipHp	5346	MA_HipHopLoop25	4/4	2	96	○		:
DrPc	HipHp	5347	MA_HipHopLoop26	4/4	4	86	○		:
DrPc	HipHp	5348	MA_HipHopLoop27	4/4	2	95	○		:
DrPc	HipHp	5349	MA_HipHopLoop28	4/4	4	100	○		:
DrPc	HipHp	5350	MA_HipHopLoop29	4/4	4	75	○		:
DrPc	HipHp	5351	MA_HipHopLoop30	4/4	2	96	○		:
DrPc	HipHp	5352	MA_HipHopLoop31	4/4	2	93	○		:
DrPc	HipHp	5353	MA_HipHopLoop32	4/4	2	94	○		:
DrPc	HipHp	5354	MA_HipHopLoop33	4/4	2	100	○		:
DrPc	HipHp	5355	MA_HipHopLoop34	4/4	2	88	○		:
DrPc	HipHp	5356	MA_HipHopLoop35	4/4	4	85	○		:
DrPc	HipHp	5357	MA_HipHopLoop36	4/4	4	90	○		:
DrPc	HipHp	5358	MA_HipHopLoop37	4/4	4	85	○		:
DrPc	HipHp	5359	MA_HipHopLoop38	4/4	4	98	○		:
DrPc	HipHp	5360	MA_HipHopLoop39	4/4	4	95	○		:
DrPc	HipHp	5361	MA_HipHopLoop40	4/4	2	100	○		:
DrPc	HipHp	5362	MA_HipHopLoop41	4/4	2	96	○		:
DrPc	HipHp	5363	MA_HipHopLoop42	4/4	4	100	○		:
DrPc	HipHp	5364	MA_HipHopLoop43	4/4	4	98	○		:
DrPc	HipHp	5365	MA_HipHopLoop44	4/4	4	97	○		:
DrPc	HipHp	5366	MA_HipHopLoop45	4/4	4	97	○		:
DrPc	HipHp	5367	MA_HipHopLoop46	4/4	4	95	○		:
DrPc	HipHp	5368	MA_HipHopLoop47	4/4	4	100	○		:
DrPc	HipHp	5369	MA_HipHopLoop48	4/4	4	85	○		:
DrPc	HipHp	5370	MA_HipHopLoop49	4/4	2	88	○		:
DrPc	HipHp	5371	MA_HipHopLoop50	4/4	4	86	○		:
DrPc	HipHp	5372	MA_HipHopLoop51	4/4	4	97	○		:
DrPc	HipHp	5373	MA_HipHopLoop52	4/4	4	95	○		:
DrPc	HipHp	5374	MA_HipHopLoop53	4/4	2	94	○		:
DrPc	HipHp	5375	MA_HipHopLoop54	4/4	2	80	○		:
DrPc	HipHp	5376	MA_HipHopLoop55	4/4	4	96	○		:
DrPc	HipHp	5377	MA_HipHopLoop56	4/4	4	80	○		:
DrPc	HipHp	5378	MA_HipHopLoop57	4/4	4	80	○		:
DrPc	HipHp	5379	MA_HipHopLoop58	4/4	4	78	○		:
DrPc	HipHp	5380	MA_HipHopLoop59	4/4	4	90	○		:
DrPc	HipHp	5381	MA_ChillKitHip1	4/4	2	90	○		"Chill Out Kit"
DrPc	HipHp	5382	MA_ChillKitHip2	4/4	2	90	○		"82 Chilly Break"
DrPc	HipHp	5383	MA_ChillKitHip3	4/4	2	90	○		"Chill Out Kit"
DrPc	HipHp	5384	MA_ChillKitHip4	4/4	2	90	○		:
DrPc	HipHp	5385	MA_8Z HeavyHip1	4/4	2	90	○		"8Z Glitch"
DrPc	HipHp	5386	MA_8Z HeavyHip2	4/4	2	90	○		:
DrPc	HipHp	5387	MA_8Z ElectHp1	4/4	4	90	○		"8Z Heavy Hearts"
DrPc	HipHp	5388	MA_8Z ElectHp2	4/4	2	90	○		:
DrPc	R&B-M	5389	MA_Slow & Easy	4/4	4	72	○		"Power Standard Kit 1"

Main Category	Sub Category	ARP No.	ARP Name	Time Signature	Length	Original Tempo	Accent	Random SFX	Voice Type
DrPc	R&B-M	5390	MB_Slow & Easy	4/4	4	72	○		"Power Standard Kit 1"
DrPc	R&B-M	5391	MC_Slow & Easy	4/4	4	72	○		:
DrPc	R&B-M	5392	FA_Slow & Easy	4/4	1	72	○		:
DrPc	R&B-M	5393	FB_Slow & Easy	4/4	1	72	○		:
DrPc	R&B-M	5394	FC_Slow & Easy	4/4	1	72	○		:
DrPc	R&B-M	5395	BA_Slow & Easy	4/4	1	72	○		:
DrPc	R&B-M	5396	EA_Slow & Easy	4/4	3	72	○		:
DrPc	R&B-M	5397	EB_Slow & Easy	4/4	4	72	○		:
DrPc	R&B-M	5398	MA_Pop Shuffle1	4/4	4	94	○		:
DrPc	R&B-M	5399	MB_Pop Shuffle1	4/4	4	94	○		:
DrPc	R&B-M	5400	MC_Pop Shuffle1	4/4	4	94	○		:
DrPc	R&B-M	5401	FA_Pop Shuffle1	4/4	1	94	○		:
DrPc	R&B-M	5402	FB_Pop Shuffle1	4/4	1	94	○		:
DrPc	R&B-M	5403	FC_Pop Shuffle1	4/4	1	94	○		:
DrPc	R&B-M	5404	BA_Pop Shuffle1	4/4	1	94	○		:
DrPc	R&B-M	5405	MA_Pop Shuffle2	4/4	4	80	○		"R&B Kit 3"
DrPc	R&B-M	5406	MB_Pop Shuffle2	4/4	4	80	○		:
DrPc	R&B-M	5407	MC_Pop Shuffle2	4/4	4	80	○		:
DrPc	R&B-M	5408	FA_Pop Shuffle2	4/4	1	80	○		:
DrPc	R&B-M	5409	FB_Pop Shuffle2	4/4	1	80	○		:
DrPc	R&B-M	5410	FC_Pop Shuffle2	4/4	1	80	○		:
DrPc	R&B-M	5411	BA_Pop Shuffle2	4/4	1	80	○		:
DrPc	R&B-M	5412	MA_R&B Disco	4/4	2	110	○		"Dry Standard Kit"
DrPc	R&B-M	5413	MB_R&B Disco	4/4	2	110	○		:
DrPc	R&B-M	5414	MC_R&B Disco	4/4	2	110	○		:
DrPc	R&B-M	5415	MD_R&B Disco	4/4	2	110	○		:
DrPc	R&B-M	5416	IA_R&B Disco	4/4	1	110	○		:
DrPc	R&B-M	5417	FA_R&B Disco	4/4	1	110	○		:
DrPc	R&B-M	5418	FB_R&B Disco	4/4	1	110	○		:
DrPc	R&B-M	5419	FC_R&B Disco	4/4	2	110	○		:
DrPc	R&B-M	5420	MA_Chart R&B	4/4	4	130	○		"R&B Kit 1"
DrPc	R&B-M	5421	MB_Chart R&B	4/4	4	130	○		:
DrPc	R&B-M	5422	MC_Chart R&B	4/4	4	130	○		:
DrPc	R&B-M	5423	FA_Chart R&B	4/4	1	130	○		:
DrPc	R&B-M	5424	FB_Chart R&B	4/4	1	130	○		:
DrPc	R&B-M	5425	FC_Chart R&B	4/4	1	130	○		:
DrPc	R&B-M	5426	BA_Chart R&B	4/4	1	130	○		:
DrPc	R&B-M	5427	EA_Chart R&B	4/4	5	130	○		:
DrPc	R&B-M	5428	EB_Chart R&B	4/4	10	130	○		:
DrPc	R&B-M	5429	MA1_ChartPop1	4/4	4	92	○		"Hip Hop Kit 3"
DrPc	R&B-M	5430	MB1_ChartPop1	4/4	4	92	○		:
DrPc	R&B-M	5431	MC1_ChartPop1	4/4	4	92	○		:
DrPc	R&B-M	5432	FA1_ChartPop1	4/4	1	92	○		:
DrPc	R&B-M	5433	FB1_ChartPop1	4/4	1	92	○		:
DrPc	R&B-M	5434	FC1_ChartPop1	4/4	1	92	○		:
DrPc	R&B-M	5435	BA1_ChartPop1	4/4	1	92	○		:
DrPc	R&B-M	5436	EA1_ChartPop1	4/4	3	92	○		:
DrPc	R&B-M	5437	EB1_ChartPop1	4/4	3	92	○		:
DrPc	R&B-M	5438	MA2_ChartPop1	4/4	4	92	○		"Power Standard Kit 2"
DrPc	R&B-M	5439	MB2_ChartPop1	4/4	4	92	○		:
DrPc	R&B-M	5440	MC2_ChartPop1	4/4	4	92	○		:
DrPc	R&B-M	5441	FA2_ChartPop1	4/4	1	92	○		:
DrPc	R&B-M	5442	FB2_ChartPop1	4/4	1	92	○		:
DrPc	R&B-M	5443	FC2_ChartPop1	4/4	1	92	○		:
DrPc	R&B-M	5444	BA2_ChartPop1	4/4	1	92	○		:
DrPc	R&B-M	5445	EA2_ChartPop1	4/4	3	92	○		:
DrPc	R&B-M	5446	EB2_ChartPop1	4/4	3	92	○		:
DrPc	R&B-M	5447	MA1_ChartPop2	4/4	2	92	○		"Hip Hop Kit 3"
DrPc	R&B-M	5448	MB1_ChartPop2	4/4	2	92	○		:
DrPc	R&B-M	5449	MC1_ChartPop2	4/4	2	92	○		:
DrPc	R&B-M	5450	MA2_ChartPop2	4/4	2	92	○		:
DrPc	R&B-M	5451	FB1_ChartPop2	4/4	1	92	○		:
DrPc	R&B-M	5452	FC1_ChartPop2	4/4	1	92	○		:
DrPc	R&B-M	5453	BA2_ChartPop2	4/4	1	92	○		:
DrPc	R&B-M	5454	EA2_ChartPop2	4/4	2	92	○		"Hip Hop Kit 1"
DrPc	R&B-M	5455	EB2_ChartPop2	4/4	2	92	○		:
DrPc	R&B-M	5456	MA2_ChartPop2	4/4	2	92	○		:
DrPc	R&B-M	5457	MB2_ChartPop2	4/4	2	92	○		:
DrPc	R&B-M	5458	FA2_ChartPop2	4/4	1	92	○		:
DrPc	R&B-M	5459	FB2_ChartPop2	4/4	1	92	○		:
DrPc	R&B-M	5460	FC2_ChartPop2	4/4	1	92	○		:
DrPc	R&B-M	5461	FA2_ChartPop2	4/4	1	92	○		:
DrPc	R&B-M	5462	MA1_R&B	4/4	2	83	○		"Power Standard Kit 1"
DrPc	R&B-M	5463	MB1_R&B						

Arpeggio Type List

Main Category	Sub Category	ARP No.	ARP Name	Time Signature	Length	Original Tempo	Accent	Random SFX	Voice Type
DrPc	R&B-M	5473	MC2_R&B	4/4	2	83	○		"R&B Kit 1"
DrPc	R&B-M	5474	FA2_R&B	4/4	1	83	○		:
DrPc	R&B-M	5475	FB2_R&B	4/4	1	83	○		:
DrPc	R&B-M	5476	FC2_R&B	4/4	1	83	○		:
DrPc	R&B-M	5477	BA2_R&B	4/4	1	83	○		:
DrPc	R&B-M	5478	EA2_R&B	4/4	4	83	○		:
DrPc	R&B-M	5479	EB2_R&B	4/4	4	83	○		:
DrPc	R&B-M	5480	MA1_New R&B 1	4/4	2	98	○		"Power Standard Kit 1"
DrPc	R&B-M	5481	MB1_New R&B 1	4/4	2	98	○		:
DrPc	R&B-M	5482	MC1_New R&B 1	4/4	2	98	○		:
DrPc	R&B-M	5483	FA1_New R&B 1	4/4	1	98	○		:
DrPc	R&B-M	5484	FB1_New R&B 1	4/4	1	98	○		:
DrPc	R&B-M	5485	FC1_New R&B 1	4/4	1	98	○		:
DrPc	R&B-M	5486	BA1_New R&B 1	4/4	1	98	○		:
DrPc	R&B-M	5487	EA1_New R&B 1	4/4	3	98	○		:
DrPc	R&B-M	5488	EB1_New R&B 1	4/4	4	98	○		:
DrPc	R&B-M	5489	MA2_New R&B 1	4/4	2	98	○		"R&B Kit 2"
DrPc	R&B-M	5490	MB2_New R&B 1	4/4	2	98	○		:
DrPc	R&B-M	5491	MC2_New R&B 1	4/4	2	98	○		:
DrPc	R&B-M	5492	FA2_New R&B 1	4/4	1	98	○		:
DrPc	R&B-M	5493	FB2_New R&B 1	4/4	1	98	○		:
DrPc	R&B-M	5494	FC2_New R&B 1	4/4	1	98	○		:
DrPc	R&B-M	5495	BA2_New R&B 1	4/4	1	98	○		:
DrPc	R&B-M	5496	EA2_New R&B 1	4/4	3	98	○		:
DrPc	R&B-M	5497	EB2_New R&B 1	4/4	4	98	○		:
DrPc	R&B-M	5498	MA1_New R&B 2	4/4	1	97	○		"Hip Hop Kit 3"
DrPc	R&B-M	5499	MB1_New R&B 2	4/4	1	97	○		:
DrPc	R&B-M	5500	MC1_New R&B 2	4/4	1	97	○		:
DrPc	R&B-M	5501	MD1_New R&B 2	4/4	1	97	○		:
DrPc	R&B-M	5502	IA1_New R&B 2	4/4	2	97	○		:
DrPc	R&B-M	5503	FA1_New R&B 2	4/4	1	97	○		:
DrPc	R&B-M	5504	FB1_New R&B 2	4/4	1	97	○		:
DrPc	R&B-M	5505	FC1_New R&B 2	4/4	2	97	○		:
DrPc	R&B-M	5506	MA2_New R&B 3	4/4	2	90	○		:
DrPc	R&B-M	5507	MB2_New R&B 3	4/4	2	90	○		:
DrPc	R&B-M	5508	MC2_New R&B 3	4/4	2	90	○		:
DrPc	R&B-M	5509	MD2_New R&B 3	4/4	2	90	○		:
DrPc	R&B-M	5510	IA2_New R&B 3	4/4	2	90	○		:
DrPc	R&B-M	5511	FA2_New R&B 3	4/4	1	90	○		:
DrPc	R&B-M	5512	FB2_New R&B 3	4/4	1	90	○		:
DrPc	R&B-M	5513	FC2_New R&B 3	4/4	2	90	○		:
DrPc	R&B-M	5514	MA_Pop R&B	4/4	4	67	○		"Hip Hop Kit 1"
DrPc	R&B-M	5515	MB_Pop R&B	4/4	4	67	○		:
DrPc	R&B-M	5516	MC_Pop R&B	4/4	4	67	○		:
DrPc	R&B-M	5517	FA_Pop R&B	4/4	1	67	○		:
DrPc	R&B-M	5518	FB_Pop R&B	4/4	1	67	○		:
DrPc	R&B-M	5519	FC_Pop R&B	4/4	1	67	○		:
DrPc	R&B-M	5520	BA_Pop R&B	4/4	1	67	○		:
DrPc	R&B-M	5521	MA_H-R&B Pop	4/4	4	140	○		"R&B Kit 1"
DrPc	R&B-M	5522	MB_H-R&B Pop	4/4	4	140	○		:
DrPc	R&B-M	5523	MC_H-R&B Pop	4/4	4	140	○		:
DrPc	R&B-M	5524	FA_H-R&B Pop	4/4	1	140	○		:
DrPc	R&B-M	5525	FB_H-R&B Pop	4/4	1	140	○		:
DrPc	R&B-M	5526	FC_H-R&B Pop	4/4	1	140	○		:
DrPc	R&B-M	5527	BA_H-R&B Pop	4/4	1	140	○		:
DrPc	R&B-M	5528	MA_J-R&B Pop	4/4	4	100	○		"Hip Hop Kit 4"
DrPc	R&B-M	5529	MB_J-R&B Pop	4/4	4	100	○		:
DrPc	R&B-M	5530	MC_J-R&B Pop	4/4	4	100	○		:
DrPc	R&B-M	5531	FA_J-R&B Pop	4/4	1	100	○		:
DrPc	R&B-M	5532	FB_J-R&B Pop	4/4	1	100	○		:
DrPc	R&B-M	5533	FC_J-R&B Pop	4/4	1	100	○		:
DrPc	R&B-M	5534	BA_J-R&B Pop	4/4	1	100	○		:
DrPc	R&B-M	5535	MA_R&B Ana Pop	4/4	4	95	○		"Hip Hop Kit 1"
DrPc	R&B-M	5536	MB_R&B Ana Pop	4/4	4	95	○		:
DrPc	R&B-M	5537	MC_R&B Ana Pop	4/4	4	95	○		:
DrPc	R&B-M	5538	FA_R&B Ana Pop	4/4	1	95	○		:
DrPc	R&B-M	5539	FB_R&B Ana Pop	4/4	1	95	○		:
DrPc	R&B-M	5540	FC_R&B Ana Pop	4/4	1	95	○		:
DrPc	R&B-M	5541	BA_R&B Ana Pop	4/4	1	95	○		:
DrPc	R&B-M	5542	MA_R&B Ballad 1	4/4	4	70	○		"Hip Hop Kit 4"
DrPc	R&B-M	5543	MB_R&B Ballad 1	4/4	4	70	○		:
DrPc	R&B-M	5544	MC_R&B Ballad 1	4/4	4	70	○		:
DrPc	R&B-M	5545	FA_R&B Ballad 1	4/4	1	70	○		:
DrPc	R&B-M	5546	FB_R&B Ballad 1	4/4	1	70	○		:
DrPc	R&B-M	5547	FC_R&B Ballad 1	4/4	1	70	○		:
DrPc	R&B-M	5548	BA_R&B Ballad 1	4/4	1	70	○		:
DrPc	R&B-M	5549	MA1_R&B Ballad 2	4/4	2	60	○		"Hip Hop Kit 2"
DrPc	R&B-M	5550	MB1_R&B Ballad 2	4/4	2	60	○		:
DrPc	R&B-M	5551	MC1_R&B Ballad 2	4/4	2	60	○		:
DrPc	R&B-M	5552	MD1_R&B Ballad 2	4/4	2	60	○		:
DrPc	R&B-M	5553	FA1_R&B Ballad 2	4/4	1	60	○		:
DrPc	R&B-M	5554	FB1_R&B Ballad 2	4/4	1	60	○		:
DrPc	R&B-M	5555	FC1_R&B Ballad 2	4/4	1	60	○		:

Main Category	Sub Category	ARP No.	ARP Name	Time Signature	Length	Original Tempo	Accent	Random SFX	Voice Type
DrPc	R&B-M	5556	FD1_R&B Ballad 2	4/4	1	60	○		"Hip Hop Kit 2"
DrPc	R&B-M	5557	MA2_R&B Ballad 2	4/4	2	60	○		"Hip Hop Kit 1"
DrPc	R&B-M	5558	MB2_R&B Ballad 2	4/4	2	60	○		:
DrPc	R&B-M	5559	MC2_R&B Ballad 2	4/4	2	60	○		:
DrPc	R&B-M	5560	MD2_R&B Ballad 2	4/4	2	60	○		:
DrPc	R&B-M	5561	FA2_R&B Ballad 2	4/4	1	60	○		:
DrPc	R&B-M	5562	FB2_R&B Ballad 2	4/4	1	60	○		:
DrPc	R&B-M	5563	FC2_R&B Ballad 2	4/4	1	60	○		:
DrPc	R&B-M	5564	FD2_R&B Ballad 2	4/4	1	60	○		:
DrPc	R&B-M	5565	MA_R&B Ballad 3	4/4	4	113	○		"R&B Kit 2"
DrPc	R&B-M	5566	MB_R&B Ballad 3	4/4	4	113	○		:
DrPc	R&B-M	5567	MC_R&B Ballad 3	4/4	4	113	○		:
DrPc	R&B-M	5568	FA_R&B Ballad 3	4/4	1	113	○		:
DrPc	R&B-M	5569	FB_R&B Ballad 3	4/4	1	113	○		:
DrPc	R&B-M	5570	FC_R&B Ballad 3	4/4	1	113	○		:
DrPc	R&B-M	5571	BA_R&B Ballad 3	4/4	1	113	○		:
DrPc	R&B-M	5572	MA_6/8 R&B	4/4	2	61	○		"Hip Hop Kit 3"
DrPc	R&B-M	5573	MB_6/8 R&B	4/4	2	61	○		:
DrPc	R&B-M	5574	MC_6/8 R&B	4/4	2	61	○		:
DrPc	R&B-M	5575	MD_6/8 R&B	4/4	2	61	○		:
DrPc	R&B-M	5576	IA_6/8 R&B	4/4	2	61	○		:
DrPc	R&B-M	5577	FA_6/8 R&B	4/4	1	61	○		:
DrPc	R&B-M	5578	FB_6/8 R&B	4/4	1	61	○		:
DrPc	R&B-M	5579	FC_6/8 R&B	4/4	2	61	○		:
DrPc	R&B-M	5580	MA_Smooth 1	4/4	2	115	○		:
DrPc	R&B-M	5581	MB_Smooth 1	4/4	2	115	○		:
DrPc	R&B-M	5582	MC_Smooth 1	4/4	2	115	○		:
DrPc	R&B-M	5583	MD_Smooth 1	4/4	2	115	○		:
DrPc	R&B-M	5584	IA_Smooth 1	4/4	2	115	○		:
DrPc	R&B-M	5585	FA_Smooth 1	4/4	1	115	○		:
DrPc	R&B-M	5586	FB_Smooth 1	4/4	1	115	○		:
DrPc	R&B-M	5587	FC_Smooth 1	4/4	2	115	○		:
DrPc	R&B-M	5588	MA_Smooth 2	4/4	4	64	○		"Hip Hop Kit 1"
DrPc	R&B-M	5589	MB_Smooth 2	4/4	4	64	○		:
DrPc	R&B-M	5590	MC_Smooth 2	4/4	4	64	○		:
DrPc	R&B-M	5591	MD_Smooth 2	4/4	4	64	○		:
DrPc	R&B-M	5592	MA_Flip Hop 1	4/4	2	132	○		"Hip Hop Kit 3"
DrPc	R&B-M	5593	MB_Flip Hop 1	4/4	2	132	○		:
DrPc	R&B-M	5594	MC_Flip Hop 1	4/4	2	132	○		:
DrPc	R&B-M	5595	MD_Flip Hop 1	4/4	2	132	○		:
DrPc	R&B-M	5596	IA_Flip Hop 1	4/4	2	132	○		:
DrPc	R&B-M	5597	FA_Flip Hop 1	4/4	1	132	○		:
DrPc	R&B-M	5598	FB_Flip Hop 1	4/4	1	132	○		:
DrPc	R&B-M	5599	FC_Flip Hop 1	4/4	4	132	○		:
DrPc	R&B-M	5600	MA_Flip Hop 2	4/4	4	125	○		:
DrPc	R&B-M	5601	MB_Flip Hop 2	4/4	4	125	○		:
DrPc	R&B-M	5602	MC_Flip Hop 2	4/4	4	125	○		:
DrPc	R&B-M	5603	MD_Flip Hop 2	4/4	4	125	○		:
DrPc	R&B-M	5604	MA_New Gospel	4/4	2	90	○		:
DrPc	R&B-M	5605	MB_New Gospel	4/4	2	90	○		:
DrPc	R&B-M	5606	MC_New Gospel	4/4	2	90	○		:
DrPc	R&B-M	5607	MD_New Gospel	4/4	2	90	○		:
DrPc	R&B-M	5608	IA_New Gospel	4/4	1	90	○		:
DrPc	R&B-M	5609	FA_New Gospel	4/4	1	90	○		:
DrPc	R&B-M	5610	FB_New Gospel	4/4	1	90	○		:
DrPc	R&B-M	5611	FC_New Gospel	4/4	2	90	○		:
DrPc	R&B-C	5612	MA1_StandrdDisco	4/4	4	120	○		"Power Standard Kit 2"
DrPc	R&B-C	5613	MB1_StandrdDisco	4/4	4	120	○		:
DrPc	R&B-C	5614	MC1_StandrdDisco	4/4	4	120	○		:
DrPc	R&B-C	5615	FA1_StandrdDisco	4/4	1	120	○		:
DrPc	R&B-C	5616	FB1_StandrdDisco	4/4	1	120	○		:
DrPc	R&B-C	5617	FC1_StandrdDisco	4/4	1	120	○		:
DrPc	R&B-C	5618	BA1_StandrdDisco	4/4	1	120	○		:
DrPc	R&B-C	5619	EA1_StandrdDisco	4/4	3	120	○		:
DrPc	R&B-C	5620	EB1_StandrdDisco	4/4	3	120	○		:
DrPc	R&B-C	5621	MA2_StandrdDisco	4/4	4	120	○		"Pop Latin Kit"
DrPc	R&B-C	5622	MB2_StandrdDisco	4/4	4	120	○		:
DrPc	R&B-C	5623	MC2_StandrdDisco	4/4	4	120	○		:
DrPc	R&B-C	5624	FA2_StandrdDisco	4					

Arpeggio Type List

Main Category	Sub Category	ARP No.	ARP Name	Time Signature	Length	Original Tempo	Accent	Random SFX	Voice Type
DrPc	R&B-C	5639	MA2_Retro Disco	4/4	4	108	○		"Pop Latin Kit"
DrPc	R&B-C	5640	MB2_Retro Disco	4/4	4	108	○		:
DrPc	R&B-C	5641	MC2_Retro Disco	4/4	4	108	○		:
DrPc	R&B-C	5642	FA2_Retro Disco	4/4	1	108	○		:
DrPc	R&B-C	5643	FB2_Retro Disco	4/4	1	108	○		:
DrPc	R&B-C	5644	FC2_Retro Disco	4/4	1	108	○		:
DrPc	R&B-C	5645	BA2_Retro Disco	4/4	1	108	○		:
DrPc	R&B-C	5646	EA2_Retro Disco	4/4	4	108	○		:
DrPc	R&B-C	5647	EB2_Retro Disco	4/4	4	108	○		:
DrPc	R&B-C	5648	MA1_70sCoolDisco	4/4	4	114	○		"Power Standard Kit 1"
DrPc	R&B-C	5649	MB1_70sCoolDisco	4/4	4	114	○		:
DrPc	R&B-C	5650	MC1_70sCoolDisco	4/4	4	114	○		:
DrPc	R&B-C	5651	FA1_70sCoolDisco	4/4	1	114	○		:
DrPc	R&B-C	5652	FB1_70sCoolDisco	4/4	1	114	○		:
DrPc	R&B-C	5653	FC1_70sCoolDisco	4/4	1	114	○		:
DrPc	R&B-C	5654	BA1_70sCoolDisco	4/4	1	114	○		:
DrPc	R&B-C	5655	EA1_70sCoolDisco	4/4	4	114	○		:
DrPc	R&B-C	5656	EB1_70sCoolDisco	4/4	3	114	○		:
DrPc	R&B-C	5657	MA2_70sCoolDisco	4/4	4	114	○		"Pop Latin Kit"
DrPc	R&B-C	5658	MB2_70sCoolDisco	4/4	4	114	○		:
DrPc	R&B-C	5659	MC2_70sCoolDisco	4/4	4	114	○		:
DrPc	R&B-C	5660	FA2_70sCoolDisco	4/4	1	114	○		:
DrPc	R&B-C	5661	FB2_70sCoolDisco	4/4	1	114	○		:
DrPc	R&B-C	5662	FC2_70sCoolDisco	4/4	1	114	○		:
DrPc	R&B-C	5663	BA2_70sCoolDisco	4/4	1	114	○		:
DrPc	R&B-C	5664	EA2_70sCoolDisco	4/4	4	114	○		:
DrPc	R&B-C	5665	EB2_70sCoolDisco	4/4	3	114	○		:
DrPc	R&B-C	5666	MA_Philadelphia	4/4	2	100	○		"Power Standard Kit 1"
DrPc	R&B-C	5667	MB_Philadelphia	4/4	2	100	○		:
DrPc	R&B-C	5668	MC_Philadelphia	4/4	2	100	○		:
DrPc	R&B-C	5669	FA_Philadelphia	4/4	1	100	○		:
DrPc	R&B-C	5670	FB_Philadelphia	4/4	1	100	○		:
DrPc	R&B-C	5671	FC_Philadelphia	4/4	1	100	○		:
DrPc	R&B-C	5672	BA_Philadelphia	4/4	1	100	○		:
DrPc	R&B-C	5673	EA_Philadelphia	4/4	4	100	○		:
DrPc	R&B-C	5674	EB_Philadelphia	4/4	3	100	○		:
DrPc	R&B-C	5675	MA_Soul 1	4/4	2	116	○		:
DrPc	R&B-C	5676	MB_Soul 1	4/4	2	116	○		:
DrPc	R&B-C	5677	MC_Soul 1	4/4	2	116	○		:
DrPc	R&B-C	5678	FA_Soul 1	4/4	1	116	○		:
DrPc	R&B-C	5679	FB_Soul 1	4/4	1	116	○		:
DrPc	R&B-C	5680	FC_Soul 1	4/4	1	116	○		:
DrPc	R&B-C	5681	BA_Soul 1	4/4	1	116	○		:
DrPc	R&B-C	5682	EA_Soul 1	4/4	4	116	○		:
DrPc	R&B-C	5683	EB_Soul 1	4/4	3	116	○		:
DrPc	R&B-C	5684	MA_Soul 2	4/4	4	120	○		"Dry Standard Kit"
DrPc	R&B-C	5685	MB_Soul 2	4/4	4	120	○		:
DrPc	R&B-C	5686	MC_Soul 2	4/4	4	120	○		:
DrPc	R&B-C	5687	MD_Soul 2	4/4	4	120	○		:
DrPc	R&B-C	5688	IA_Soul 2	4/4	1	120	○		:
DrPc	R&B-C	5689	FA_Soul 2	4/4	1	120	○		:
DrPc	R&B-C	5690	FB_Soul 2	4/4	1	120	○		:
DrPc	R&B-C	5691	FC_Soul 2	4/4	4	120	○		:
DrPc	R&B-C	5692	MA1_Soul 3	4/4	4	88	○		"Hip Hop Kit 3"
DrPc	R&B-C	5693	MB1_Soul 3	4/4	4	88	○		:
DrPc	R&B-C	5694	MC1_Soul 3	4/4	4	88	○		:
DrPc	R&B-C	5695	MD1_Soul 3	4/4	4	88	○		:
DrPc	R&B-C	5696	FA1_Soul 3	4/4	1	88	○		:
DrPc	R&B-C	5697	FB1_Soul 3	4/4	1	88	○		:
DrPc	R&B-C	5698	FC1_Soul 3	4/4	1	88	○		:
DrPc	R&B-C	5699	FD1_Soul 3	4/4	1	88	○		:
DrPc	R&B-C	5700	MA2_Soul 3	4/4	4	88	○		"Hip Hop Kit 1"
DrPc	R&B-C	5701	MB2_Soul 3	4/4	4	88	○		:
DrPc	R&B-C	5702	MC2_Soul 3	4/4	4	88	○		:
DrPc	R&B-C	5703	MD2_Soul 3	4/4	4	88	○		:
DrPc	R&B-C	5704	FA2_Soul 3	4/4	1	88	○		:
DrPc	R&B-C	5705	FB2_Soul 3	4/4	1	88	○		:
DrPc	R&B-C	5706	FC2_Soul 3	4/4	1	88	○		:
DrPc	R&B-C	5707	FD2_Soul 3	4/4	1	88	○		:
DrPc	R&B-C	5708	MA_70sChartSoul	4/4	2	108	○		"Power Standard Kit 2"
DrPc	R&B-C	5709	MB_70sChartSoul	4/4	2	108	○		:
DrPc	R&B-C	5710	MC_70sChartSoul	4/4	2	108	○		:
DrPc	R&B-C	5711	FA_70sChartSoul	4/4	1	108	○		:
DrPc	R&B-C	5712	FB_70sChartSoul	4/4	1	108	○		:
DrPc	R&B-C	5713	FC_70sChartSoul	4/4	1	108	○		:
DrPc	R&B-C	5714	BA_70sChartSoul	4/4	1	108	○		:
DrPc	R&B-C	5715	EA_70sChartSoul	4/4	5	108	○		:
DrPc	R&B-C	5716	EB_70sChartSoul	4/4	3	108	○		:
DrPc	R&B-C	5717	MA_Frankly Soul	4/4	4	120	○		"Power Standard Kit 1"
DrPc	R&B-C	5718	MB_Frankly Soul	4/4	4	120	○		:
DrPc	R&B-C	5719	MC_Frankly Soul	4/4	4	120	○		:
DrPc	R&B-C	5720	FA_Frankly Soul	4/4	1	120	○		:
DrPc	R&B-C	5721	FB_Frankly Soul	4/4	1	120	○		:

Main Category	Sub Category	ARP No.	ARP Name	Time Signature	Length	Original Tempo	Accent	Random SFX	Voice Type
DrPc	R&B-C	5722	FC_Frankly Soul	4/4	1	120	○		"Power Standard Kit 1"
DrPc	R&B-C	5723	BA_Frankly Soul	4/4	1	120	○		:
DrPc	R&B-C	5724	EA_Frankly Soul	4/4	3	120	○		:
DrPc	R&B-C	5725	EB_Frankly Soul	4/4	4	120	○		:
DrPc	R&B-C	5726	MA_Soul Beat	4/4	4	124	○		:
DrPc	R&B-C	5727	MB_Soul Beat	4/4	4	124	○		:
DrPc	R&B-C	5728	MC_Soul Beat	4/4	4	124	○		:
DrPc	R&B-C	5729	FA_Soul Beat	4/4	1	124	○		:
DrPc	R&B-C	5730	FB_Soul Beat	4/4	1	124	○		:
DrPc	R&B-C	5731	FC_Soul Beat	4/4	1	124	○		:
DrPc	R&B-C	5732	BA_Soul Beat	4/4	1	124	○		:
DrPc	R&B-C	5733	EA_Soul Beat	4/4	3	123	○		:
DrPc	R&B-C	5734	EB_Soul Beat	4/4	3	123	○		:
DrPc	R&B-C	5735	MA_Soul Band	4/4	4	129	○		"Power Standard Kit 2"
DrPc	R&B-C	5736	MB_Soul Band	4/4	4	129	○		:
DrPc	R&B-C	5737	MC_Soul Band	4/4	4	129	○		:
DrPc	R&B-C	5738	FA_Soul Band	4/4	1	129	○		:
DrPc	R&B-C	5739	FB_Soul Band	4/4	1	129	○		:
DrPc	R&B-C	5740	FC_Soul Band	4/4	1	129	○		:
DrPc	R&B-C	5741	BA_Soul Band	4/4	1	129	○		:
DrPc	R&B-C	5742	MA_Soul Shuffle	4/4	4	98	○		:
DrPc	R&B-C	5743	MB_Soul Shuffle	4/4	4	98	○		:
DrPc	R&B-C	5744	MC_Soul Shuffle	4/4	4	98	○		:
DrPc	R&B-C	5745	FA_Soul Shuffle	4/4	1	98	○		:
DrPc	R&B-C	5746	FB_Soul Shuffle	4/4	1	98	○		:
DrPc	R&B-C	5747	FC_Soul Shuffle	4/4	1	98	○		:
DrPc	R&B-C	5748	BA_Soul Shuffle	4/4	1	98	○		:
DrPc	R&B-C	5749	EA_Soul Shuffle	4/4	3	98	○		:
DrPc	R&B-C	5750	EB_Soul Shuffle	4/4	3	98	○		:
DrPc	R&B-C	5751	MA_Soul Swing	4/4	4	124	○		"Power Standard Kit 1"
DrPc	R&B-C	5752	MB_Soul Swing	4/4	4	124	○		:
DrPc	R&B-C	5753	MC_Soul Swing	4/4	4	124	○		:
DrPc	R&B-C	5754	FA_Soul Swing	4/4	1	124	○		:
DrPc	R&B-C	5755	FB_Soul Swing	4/4	1	124	○		:
DrPc	R&B-C	5756	FC_Soul Swing	4/4	1	124	○		:
DrPc	R&B-C	5757	BA_Soul Swing	4/4	1	124	○		:
DrPc	R&B-C	5758	EA_Soul Swing	4/4	3	123	○		:
DrPc	R&B-C	5759	EB_Soul Swing	4/4	5	123	○		:
DrPc	R&B-C	5760	MA_GospelBrothr	4/4	4	108	○		:
DrPc	R&B-C	5761	MB_GospelBrothr	4/4	4	108	○		:
DrPc	R&B-C	5762	MC_GospelBrothr	4/4	4	108	○		:
DrPc	R&B-C	5763	FA_GospelBrothr	4/4	1	108	○		:
DrPc	R&B-C	5764	FB_GospelBrothr	4/4	1	108	○		:
DrPc	R&B-C	5765	FC_GospelBrothr	4/4	1	108	○		:
DrPc	R&B-C	5766	BA_GospelBrothr	4/4	1	108	○		:
DrPc	R&B-C	5767	EA_GospelBrothr	4/4	4	108	○		:
DrPc	R&B-C	5768	EB_GospelBrothr	4/4	3	108	○		:
DrPc	R&B-C	5769	MA_Gospel	3/4	4	126	○		"Dry Standard Kit"
DrPc	R&B-C	5770	MB_Gospel	3/4	2	126	○		:
DrPc	Funk	5771	MA_Funk 1	4/4	8	104	○		"Power Standard Kit 1"
DrPc	Funk	5772	MB_Funk 1	4/4	8	104	○		:
DrPc	Funk	5773	MC_Funk 1	4/4	8	104	○		:
DrPc	Funk	5774	FA_Funk 1	4/4	1	104	○		:
DrPc	Funk	5775	FB_Funk 1	4/4	1	104	○		:
DrPc	Funk	5776	FC_Funk 1	4/4	1	104	○		:
DrPc	Funk	5777	BA_Funk 1	4/4	1	104	○		:
DrPc	Funk	5778	EA_Funk 1	4/4	9	104	○		:
DrPc	Funk	5779	EB_Funk 1	4/4	4	104	○		:
DrPc	Funk	5780	MA_Funk 2 /1	4/4	4	107	○		"Hyper Standard Kit"
DrPc	Funk	5781	MB_Funk 2 /1	4/4	4	107	○		:
DrPc	Funk	5782	MC_Funk 2	4/4	4	107	○		:
DrPc	Funk	5783	MD_Funk 2	4/4	4	107	○		:
DrPc	Funk	5784	IA_Funk 2	4/4	4	107	○		:
DrPc	Funk	5785	FA_Funk 2	4/4	1	107	○		:
DrPc	Funk	5786	FB_Funk 2 /1	4/4	1	107	○		:
DrPc	Funk	5787	FC_Funk 2 /1	4/4	1	107	○		:
DrPc	Funk	5788	MA_Funk 2 /2	4/4	2	107	○		:
DrPc	Funk	5789	MB_Funk 2 /2	4/4	4	107	○		:
DrPc	Funk	5790	FB_Funk 2 /2	4/4	1	107	○		:
DrPc	Funk	5791	FC_Funk 2 /2	4/4	1	107	○		:
DrPc	Funk	5792	MA_Funk 3	4/4	2	132	○		"Dry Standard Kit"
DrPc	Funk	5793	MB_Funk 3	4/4	2	132	○		:
DrPc	Funk	5794	MC_Funk 3	4/4	4	132	○		

Arpeggio Type List

Main Category	Sub Category	ARP No.	ARP Name	Time Signature	Length	Original Tempo	Accent	Random SFX	Voice Type
DrPc	Funk	5805	MB_Cool Funk	4/4	2	96	○		"Hyper Standard Kit"
DrPc	Funk	5806	MC_Cool Funk	4/4	2	96	○		:
DrPc	Funk	5807	MD_Cool Funk	4/4	2	96	○		:
DrPc	Funk	5808	IA_Cool Funk	4/4	2	96	○		:
DrPc	Funk	5809	FA_Cool Funk	4/4	1	96	○		:
DrPc	Funk	5810	FB_Cool Funk	4/4	1	96	○		:
DrPc	Funk	5811	FC_Cool Funk	4/4	2	96	○		:
DrPc	Funk	5812	MA_Funk PopRock	4/4	4	95	○		"Power Standard Kit 1"
DrPc	Funk	5813	MB_Funk PopRock	4/4	4	95	○		:
DrPc	Funk	5814	MC_Funk PopRock	4/4	4	95	○		:
DrPc	Funk	5815	FA_Funk PopRock	4/4	1	95	○		:
DrPc	Funk	5816	FB_Funk PopRock	4/4	1	95	○		:
DrPc	Funk	5817	FC_Funk PopRock	4/4	1	95	○		:
DrPc	Funk	5818	BA_Funk PopRock	4/4	1	95	○		:
DrPc	Funk	5819	EA_Funk PopRock	4/4	4	94	○		:
DrPc	Funk	5820	EB_Funk PopRock	4/4	3	94	○		:
DrPc	Funk	5821	MA_Jazz Funk 1	4/4	4	120	○		:
DrPc	Funk	5822	MB_Jazz Funk 1	4/4	4	120	○		:
DrPc	Funk	5823	MC_Jazz Funk 1	4/4	4	120	○		:
DrPc	Funk	5824	FA_Jazz Funk 1	4/4	1	120	○		:
DrPc	Funk	5825	FB_Jazz Funk 1	4/4	1	120	○		:
DrPc	Funk	5826	FC_Jazz Funk 1	4/4	1	120	○		:
DrPc	Funk	5827	BA_Jazz Funk 1	4/4	1	120	○		:
DrPc	Funk	5828	EA_Jazz Funk 1	4/4	3	120	○		:
DrPc	Funk	5829	EB_Jazz Funk 1	4/4	3	120	○		:
DrPc	Funk	5830	MA_Jazz Funk 2	4/4	4	120	○		"Dry Standard Kit"
DrPc	Funk	5831	MB_Jazz Funk 2	4/4	4	120	○		:
DrPc	Funk	5832	MC_Jazz Funk 2	4/4	4	120	○		:
DrPc	Funk	5833	MD_Jazz Funk 2	4/4	4	120	○		:
DrPc	Funk	5834	IA_Jazz Funk 2	4/4	2	120	○		:
DrPc	Funk	5835	FA_Jazz Funk 2	4/4	1	120	○		:
DrPc	Funk	5836	FB_Jazz Funk 2	4/4	1	120	○		:
DrPc	Funk	5837	FC_Jazz Funk 2	4/4	1	120	○		:
DrPc	Funk	5838	MA1_Jazz Funk 3	4/4	4	123	○		"Hip Hop Kit 1"
DrPc	Funk	5839	MB1_Jazz Funk 3	4/4	4	123	○		:
DrPc	Funk	5840	MC1_Jazz Funk 3	4/4	4	123	○		:
DrPc	Funk	5841	MD1_Jazz Funk 3	4/4	2	123	○		:
DrPc	Funk	5842	FA1_Jazz Funk 3	4/4	1	123	○		:
DrPc	Funk	5843	FB1_Jazz Funk 3	4/4	1	123	○		:
DrPc	Funk	5844	FC1_Jazz Funk 3	4/4	1	123	○		:
DrPc	Funk	5845	FD1_Jazz Funk 3	4/4	1	123	○		:
DrPc	Funk	5846	MA2_Jazz Funk 3	4/4	4	123	○		"Latin Percussion Kit"
DrPc	Funk	5847	MB2_Jazz Funk 3	4/4	4	123	○		:
DrPc	Funk	5848	MC2_Jazz Funk 3	4/4	4	123	○		:
DrPc	Funk	5849	MD2_Jazz Funk 3	4/4	2	123	○		:
DrPc	Funk	5850	FA2_Jazz Funk 3	4/4	1	123	○		:
DrPc	Funk	5851	FB2_Jazz Funk 3	4/4	1	123	○		:
DrPc	Funk	5852	FC2_Jazz Funk 3	4/4	1	123	○		:
DrPc	Funk	5853	FD2_Jazz Funk 3	4/4	1	123	○		:
DrPc	Funk	5854	MA_Jazz Pop	4/4	2	102	○		"Power Standard Kit 1"
DrPc	Funk	5855	MB_Jazz Pop	4/4	2	102	○		:
DrPc	Funk	5856	MC_Jazz Pop	4/4	2	102	○		:
DrPc	Funk	5857	FA_Jazz Pop	4/4	1	102	○		:
DrPc	Funk	5858	FB_Jazz Pop	4/4	1	102	○		:
DrPc	Funk	5859	FC_Jazz Pop	4/4	1	102	○		:
DrPc	Funk	5860	BA_Jazz Pop	4/4	1	102	○		:
DrPc	Funk	5861	MA_Club Jazz 1	4/4	4	125	○		:
DrPc	Funk	5862	MB_Club Jazz 1	4/4	4	125	○		:
DrPc	Funk	5863	MC_Club Jazz 1	4/4	4	125	○		:
DrPc	Funk	5864	FA_Club Jazz 1	4/4	1	125	○		:
DrPc	Funk	5865	FB_Club Jazz 1	4/4	1	125	○		:
DrPc	Funk	5866	FC_Club Jazz 1	4/4	1	125	○		:
DrPc	Funk	5867	BA_Club Jazz 1	4/4	1	125	○		:
DrPc	Funk	5868	MA_Club Jazz 2	4/4	4	92	○		:
DrPc	Funk	5869	MB_Club Jazz 2	4/4	4	92	○		:
DrPc	Funk	5870	MC_Club Jazz 2	4/4	4	92	○		:
DrPc	Funk	5871	FA_Club Jazz 2	4/4	1	92	○		:
DrPc	Funk	5872	FB_Club Jazz 2	4/4	1	92	○		:
DrPc	Funk	5873	FC_Club Jazz 2	4/4	1	92	○		:
DrPc	Funk	5874	BA_Club Jazz 2	4/4	1	92	○		:
DrPc	Funk	5875	MA_Gospel Funk	4/4	4	106	○		:
DrPc	Funk	5876	MB_Gospel Funk	4/4	4	106	○		:
DrPc	Funk	5877	MC_Gospel Funk	4/4	4	106	○		:
DrPc	Funk	5878	FA_Gospel Funk	4/4	1	106	○		:
DrPc	Funk	5879	FB_Gospel Funk	4/4	1	106	○		:
DrPc	Funk	5880	FC_Gospel Funk	4/4	1	106	○		:
DrPc	Funk	5881	BA_Gospel Funk	4/4	1	106	○		:
DrPc	Funk	5882	EA_Gospel Funk	4/4	4	106	○		:
DrPc	Funk	5883	EB_Gospel Funk	4/4	3	106	○		:
DrPc	Funk	5884	MA_Funk Disco	4/4	2	126	○		"Power Standard Kit 2"
DrPc	Funk	5885	MB_Funk Disco	4/4	2	126	○		:
DrPc	Funk	5886	MC_Funk Disco	4/4	2	126	○		:
DrPc	Funk	5887	FA_Funk Disco	4/4	1	126	○		:

Main Category	Sub Category	ARP No.	ARP Name	Time Signature	Length	Original Tempo	Accent	Random SFX	Voice Type
DrPc	Funk	5888	FB_Funk Disco	4/4	1	126	○		"Power Standard Kit 2"
DrPc	Funk	5889	FC_Funk Disco	4/4	1	126	○		:
DrPc	Funk	5890	BA_Funk Disco	4/4	1	126	○		:
DrPc	Funk	5891	EA_Funk Disco	4/4	4	126	○		:
DrPc	Funk	5892	EB_Funk Disco	4/4	3	126	○		:
DrPc	Funk	5893	MA_70sDiscoFunk	4/4	4	112	○		"Power Standard Kit 1"
DrPc	Funk	5894	MB_70sDiscoFunk	4/4	4	112	○		:
DrPc	Funk	5895	MC_70sDiscoFunk	4/4	4	112	○		:
DrPc	Funk	5896	FA_70sDiscoFunk	4/4	1	112	○		:
DrPc	Funk	5897	FB_70sDiscoFunk	4/4	1	112	○		:
DrPc	Funk	5898	FC_70sDiscoFunk	4/4	1	112	○		:
DrPc	Funk	5899	BA_70sDiscoFunk	4/4	1	112	○		:
DrPc	Funk	5900	EA_70sDiscoFunk	4/4	4	112	○		:
DrPc	Funk	5901	EB_70sDiscoFunk	4/4	3	112	○		:
DrPc	Funk	5902	MA_Oak Custom	4/4	2	114	○		"OakCustom Kit"
DrPc	Funk	5903	MB_Oak Custom	4/4	2	114	○		:
DrPc	Funk	5904	MC_Oak Custom	4/4	2	114	○		:
DrPc	Funk	5905	FA_Oak Custom	4/4	1	114	○		:
DrPc	Funk	5906	FB_Oak Custom	4/4	1	114	○		:
DrPc	Funk	5907	EA_Oak Custom	4/4	4	114	○		:
DrPc	Tekno	5908	MA1_8Z Undergrnd	4/4	4	100	○		"8Z Noise Xpress"
DrPc	Tekno	5909	MB1_8Z Undergrnd	4/4	4	100	○		:
DrPc	Tekno	5910	MC1_8Z Undergrnd	4/4	4	100	○		:
DrPc	Tekno	5911	FA1_8Z Undergrnd	4/4	1	100	○		:
DrPc	Tekno	5912	FB1_8Z Undergrnd	4/4	1	100	○		:
DrPc	Tekno	5913	FC1_8Z Undergrnd	4/4	1	100	○		:
DrPc	Tekno	5914	BA1_8Z Undergrnd	4/4	1	100	○		:
DrPc	Tekno	5915	MA2_8Z Undergrnd	4/4	4	100	○		"8Z Oxidized"
DrPc	Tekno	5916	MB2_8Z Undergrnd	4/4	4	100	○		:
DrPc	Tekno	5917	MC2_8Z Undergrnd	4/4	4	100	○		:
DrPc	Tekno	5918	FA2_8Z Undergrnd	4/4	1	100	○		:
DrPc	Tekno	5919	FB2_8Z Undergrnd	4/4	1	100	○		:
DrPc	Tekno	5920	FC2_8Z Undergrnd	4/4	1	100	○		:
DrPc	Tekno	5921	BA2_8Z Undergrnd	4/4	1	100	○		:
DrPc	Tekno	5922	MA3_Underground	4/4	4	100	○		"Acid Kit"
DrPc	Tekno	5923	MB3_Underground	4/4	4	100	○		:
DrPc	Tekno	5924	MC3_Underground	4/4	4	100	○		:
DrPc	Tekno	5925	FA3_Underground	4/4	1	100	○		:
DrPc	Tekno	5926	FB3_Underground	4/4	1	100	○		:
DrPc	Tekno	5927	FC3_Underground	4/4	1	100	○		:
DrPc	Tekno	5928	BA3_Underground	4/4	1	100	○		:
DrPc	Tekno	5929	MA4_Underground	4/4	4	100	○		"Hard Kit"
DrPc	Tekno	5930	MB4_Underground	4/4	4	100	○		:
DrPc	Tekno	5931	MC4_Underground	4/4	4	100	○		:
DrPc	Tekno	5932	FA4_Underground	4/4	1	100	○		:
DrPc	Tekno	5933	FB4_Underground	4/4	1	100	○		:
DrPc	Tekno	5934	FC4_Underground	4/4	1	100	○		:
DrPc	Tekno	5935	BA4_Underground	4/4	1	100	○		:
DrPc	Tekno	5936	MA_8Z Destruct	4/4	4	115	○		"8Z Destruct"
DrPc	Tekno	5937	MB_8Z Destruct	4/4	4	115	○		:
DrPc	Tekno	5938	MC_8Z Destruct	4/4	4	115	○		:
DrPc	Tekno	5939	MD_8Z Destruct	4/4	4	115	○		:
DrPc	Tekno	5940	ME_8Z Destruct	4/4	2	115	○		:
DrPc	Tekno	5941	MA_8Z Jarrin	4/4	2	105	○		"8Z Jarrin"
DrPc	Tekno	5942	MB_8Z Jarrin	4/4	4	105	○		:
DrPc	Tekno	5943	MC_8Z Jarrin	4/4	4	105	○		:
DrPc	Tekno	5944	MD_8Z Jarrin	4/4	4	105	○		:
DrPc	Tekno	5945	ME_8Z Jarrin	4/4	1	105	○		:
DrPc	Tekno	5946	MA_8Z Romps	4/4	4	125	○		"8Z Romps"
DrPc	Tekno	5947	MB_8Z Romps	4/4	4	125	○		:
DrPc	Tekno	5948	MC_8Z Romps	4/4	4	125	○		:
DrPc	Tekno	5949	MD_8Z Romps	4/4	4	125	○		:
DrPc	Tekno	5950	ME_8Z Romps	4/4	2	125	○		:
DrPc	Tekno	5951	MA_Dub Element	4/4	2	120	○		"8Z Dub Element"
DrPc	Tekno	5952	MB_Dub Element	4/4	2	120	○		:
DrPc	Tekno	5953	MC_Dub Element	4/4	2	120	○		:
DrPc	Tekno	5954	FA_Dub Element	4/4	1	120	○		:
DrPc	Tekno	5955	FB_Dub Element	4/4	2	120	○		:
DrPc	Tekno	5956	FC_Dub Element	4/4	1	120	○		:
DrPc	Tekno	5957	BA_Dub Element	4/4	1	120	○		:
DrPc	Tekno	5958	MA_Electonica1	4/4	1	118	○		"Tekno Kit"
DrPc	Tekno	5959	MA_Electonica2	4/4	1	118	○		"Analog T9 Kit"
DrPc	Tekno	5960	MA_8Z Heartbrek	4/4	4	90	○		"8Z Heavy Hearts"
DrPc	Tekno	5961	MA_Sp SFX	4/4	4	100	○		"Special SFXs"
DrPc	Tekno	5962	MB_Sp SFX	4/4	4	100	○		:
DrPc	Tekno	5963	MC_Sp SFX	4/4	2	100	○		:
DrPc	Tekno	5964	FA_Sp SFX	4/4	1	1			

Arpeggio Type List

Main Category	Sub Category	ARP No.	ARP Name	Time Signature	Length	Original Tempo	Accent	Random SFX	Voice Type
DrPc	Tekno	5971	FA_Tekno 1	4/4	1	135	○		"House Kit 2"
DrPc	Tekno	5972	FB_Tekno 1	4/4	1	135	○		:
DrPc	Tekno	5973	FC_Tekno 1	4/4	1	135	○		:
DrPc	Tekno	5974	BA_Tekno 1	4/4	4	135	○		:
DrPc	Tekno	5975	MA_Tekno 2	4/4	4	137	○		"Trance Kit"
DrPc	Tekno	5976	MB_Tekno 2	4/4	4	137	○		:
DrPc	Tekno	5977	FA_Tekno 2	4/4	1	137	○		:
DrPc	Tekno	5978	FB_Tekno 2	4/4	2	137	○		:
DrPc	Tekno	5979	FC_Tekno 2	4/4	2	137	○		:
DrPc	Tekno	5980	MA1_8Z Trance 1	4/4	8	142	○		"8Z Psychedelic 1"
DrPc	Tekno	5981	MB1_8Z Trance 1	4/4	4	142	○		:
DrPc	Tekno	5982	MC1_8Z Trance 1	4/4	16	142	○		:
DrPc	Tekno	5983	FA1_8Z Trance 1	4/4	2	142	○		:
DrPc	Tekno	5984	FB1_8Z Trance 1	4/4	8	142	○		:
DrPc	Tekno	5985	FC1_8Z Trance 1	4/4	8	142	○		:
DrPc	Tekno	5986	BA1_8Z Trance 1	4/4	1	142	○		:
DrPc	Tekno	5987	MA2_8Z Trance 1	4/4	8	142	○		"Psychedelic Kit"
DrPc	Tekno	5988	MB2_8Z Trance 1	4/4	4	142	○		:
DrPc	Tekno	5989	MC2_8Z Trance 1	4/4	16	142	○		:
DrPc	Tekno	5990	FA2_8Z Trance 1	4/4	2	142	○		:
DrPc	Tekno	5991	FB2_8Z Trance 1	4/4	8	142	○		:
DrPc	Tekno	5992	FC2_8Z Trance 1	4/4	8	142	○		:
DrPc	Tekno	5993	BA2_8Z Trance 1	4/4	1	142	○		:
DrPc	Tekno	5994	MA_Trance 2	4/4	8	135	○		"Trance Kit"
DrPc	Tekno	5995	MB_Trance 2	4/4	8	135	○		:
DrPc	Tekno	5996	MC_Trance 2	4/4	8	135	○		:
DrPc	Tekno	5997	FA_Trance 2	4/4	1	135	○		:
DrPc	Tekno	5998	FB_Trance 2	4/4	8	135	○		:
DrPc	Tekno	5999	FC_Trance 2	4/4	1	135	○		:
DrPc	Tekno	6000	BA_Trance 2	4/4	1	135	○		:
DrPc	Tekno	6001	MA_8Z Trance 3	4/4	2	140	○		"8Z Psychedelic 1"
DrPc	Tekno	6002	MB_8Z Trance 3	4/4	2	140	○		:
DrPc	Tekno	6003	MC_8Z Trance 3	4/4	3	140	○		:
DrPc	Tekno	6004	FA_8Z Trance 3	4/4	2	140	○		:
DrPc	Tekno	6005	FB_8Z Trance 3	4/4	2	140	○		:
DrPc	Tekno	6006	FC_8Z Trance 3	4/4	4	140	○		:
DrPc	Tekno	6007	BA_8Z Trance 3	4/4	1	140	○		:
DrPc	Tekno	6008	MA_Trance 4	4/4	4	130	○		"Analog T8 Kit"
DrPc	Tekno	6009	MB_Trance 4	4/4	2	130	○		:
DrPc	Tekno	6010	MC_Trance 4	4/4	4	130	○		:
DrPc	Tekno	6011	FA_Trance 4	4/4	4	130	○		:
DrPc	Tekno	6012	FB_Trance 4	4/4	4	130	○		:
DrPc	Tekno	6013	BA_Trance 4	4/4	2	130	○		:
DrPc	Tekno	6014	MA_Trance 5	4/4	4	140	○		"Analog T9 Kit"
DrPc	Tekno	6015	MB_Trance 5	4/4	4	140	○		:
DrPc	Tekno	6016	MC_Trance 5	4/4	4	140	○		:
DrPc	Tekno	6017	FA_Trance 5	4/4	4	140	○		:
DrPc	Tekno	6018	FB_Trance 5	4/4	4	140	○		:
DrPc	Tekno	6019	BA_Trance 5	4/4	4	140	○		:
DrPc	Tekno	6020	MA_Trance 5	4/4	4	140	○		:
DrPc	Tekno	6021	FC_Trance 5	4/4	4	140	○		:
DrPc	Tekno	6022	ME_Trance 5/Bd1	4/4	4	140	○		:
DrPc	Tekno	6023	ME_Trance 5/Bd2	4/4	4	140	○		:
DrPc	Tekno	6024	ME_Trance 5/Bd3	4/4	4	140	○		:
DrPc	Tekno	6025	ME_Trance 5/Bd4	4/4	4	140	○		:
DrPc	Tekno	6026	ME_Trance 5/Hh1	4/4	4	140	○		:
DrPc	Tekno	6027	ME_Trance 5/Hh2	4/4	2	140	○		:
DrPc	Tekno	6028	ME_Trance 5/Hh3	4/4	1	140	○		:
DrPc	Tekno	6029	ME_Trance 5/Hh4	4/4	1	140	○		:
DrPc	Tekno	6030	ME_Trance 5/Hh5	4/4	1	140	○		:
DrPc	Tekno	6031	ME_Trance 5/Hh6	4/4	1	140	○		:
DrPc	Tekno	6032	ME_Trance 5/Hh7	4/4	1	140	○		:
DrPc	Tekno	6033	ME_Trance 5/Clp	4/4	4	140	○		:
DrPc	Tekno	6034	FD_Trance 5/Sdf	4/4	4	140	○		:
DrPc	Tekno	6035	MA1_PsycheTrance	4/4	4	143	○		"Psychedelic Kit"
DrPc	Tekno	6036	MB1_PsycheTrance	4/4	2	143	○		:
DrPc	Tekno	6037	MC1_PsycheTrance	4/4	2	143	○		:
DrPc	Tekno	6038	MD1_PsycheTrance	4/4	4	143	○		:
DrPc	Tekno	6039	ME1_PsycheTrance	4/4	4	143	○		:
DrPc	Tekno	6040	MF1_PsycheTrance	4/4	4	143	○		:
DrPc	Tekno	6041	FA1_PsycheTrance	4/4	1	143	○		:
DrPc	Tekno	6042	FB1_PsycheTrance	4/4	1	143	○		:
DrPc	Tekno	6043	FC1_PsycheTrance	4/4	1	143	○		:
DrPc	Tekno	6044	BA1_PsycheTrance	4/4	4	143	○		:
DrPc	Tekno	6045	MA2_8Z Psyche	4/4	2	140	○		"8Z Psychedelic 1"
DrPc	Tekno	6046	MB2_8Z Psyche	4/4	2	140	○		:
DrPc	Tekno	6047	MC2_8Z Psyche	4/4	2	140	○		:
DrPc	Tekno	6048	FA2_8Z Psyche	4/4	1	140	○		:
DrPc	Tekno	6049	FB2_8Z Psyche	4/4	1	140	○		:
DrPc	Tekno	6050	FC2_8Z Psyche	4/4	1	140	○		:
DrPc	Tekno	6051	BA2_8Z Psyche	4/4	2	140	○		:
DrPc	Tekno	6052	MA3_8Z Psyche	4/4	1	135	○		8Z Psychedelic 2
DrPc	Tekno	6053	MB3_8Z Psyche	4/4	1	135	○		:

Main Category	Sub Category	ARP No.	ARP Name	Time Signature	Length	Original Tempo	Accent	Random SFX	Voice Type
DrPc	Tekno	6054	MC3_8Z Psyche	4/4	2	135	○		8Z Psychedelic 2
DrPc	Tekno	6055	FA3_8Z Psyche	4/4	2	135	○		:
DrPc	Tekno	6056	FB3_8Z Psyche	4/4	1	135	○		:
DrPc	Tekno	6057	FC3_8Z Psyche	4/4	1	135	○		:
DrPc	Tekno	6058	BA3_8Z Psyche	4/4	1	135	○		:
DrPc	Tekno	6059	MA_Trance Kit 1	4/4	4	136	○		"Trance Kit"
DrPc	Tekno	6060	MA_Trance Kit 2	4/4	4	136	○		:
DrPc	Tekno	6061	MA_Trance Kit 3	4/4	4	136	○		:
DrPc	Tekno	6062	MA_Trance Kit 4	4/4	4	136	○		:
DrPc	Tekno	6063	MA_Trance Kit 5	4/4	4	136	○		:
DrPc	Tekno	6064	MA_Trance Kit 6	4/4	4	136	○		:
DrPc	Tekno	6065	MA_Trance Kit 7	4/4	1	136	○		:
DrPc	Tekno	6066	MA_Trance Kit 8	4/4	2	136	○		:
DrPc	Tekno	6067	MA_Trance Kit 9	4/4	2	136	○		:
DrPc	Tekno	6068	MA_Trance Kit10	4/4	2	136	○		:
DrPc	Tekno	6069	MA_Trance Kit11	4/4	2	136	○		:
DrPc	Tekno	6070	MA_Trance Kit12	4/4	4	136	○		:
DrPc	Tekno	6071	MA_8Z TrancBsc1	4/4	1	136	○		"8Z Trance Basics"
DrPc	Tekno	6072	MA_8Z TrancBsc2	4/4	1	136	○		:
DrPc	Tekno	6073	MA_8Z TrancBsc3	4/4	1	136	○		:
DrPc	Tekno	6074	MA_8Z TrancBsc4	4/4	1	136	○		:
DrPc	Tekno	6075	MA_8Z TrancBsc5	4/4	4	136	○		:
DrPc	Tekno	6076	MA_Trance Club1	4/4	1	128	○		"Trance Kit"
DrPc	Tekno	6077	MA_Trance Club2	4/4	1	128	○		:
DrPc	Tekno	6078	MA_Trance Club3	4/4	1	128	○		:
DrPc	Tekno	6079	MA_Trance Club4	4/4	1	128	○		:
DrPc	Tekno	6080	MA_Trance Club5	4/4	1	128	○		:
DrPc	Tekno	6081	MA_Trance Club6	4/4	1	128	○		:
DrPc	Tekno	6082	MA_Trance Vision	4/4	4	134	○		"8Z Trance Basics 2"
DrPc	Tekno	6083	MB_Trance Vision	4/4	4	134	○		:
DrPc	Tekno	6084	MC_Trance Vision	4/4	8	134	○		:
DrPc	Tekno	6085	MD_Trance Vision	4/4	4	134	○		:
DrPc	Tekno	6086	ME_Trance Vision	4/4	4	134	○		:
DrPc	Tekno	6087	MF_Trance Vision	4/4	4	134	○		:
DrPc	Tekno	6088	MG_Trance Vision	4/4	4	134	○		:
DrPc	Tekno	6089	MH_Trance Vision	4/4	4	134	○		:
DrPc	Tekno	6090	MA_Dream Trance	4/4	4	140	○		:
DrPc	Tekno	6091	MB_Dream Trance	4/4	4	140	○		:
DrPc	Tekno	6092	MC_Dream Trance	4/4	4	140	○		:
DrPc	Tekno	6093	MD_Dream Trance	4/4	4	140	○		:
DrPc	Tekno	6094	MA_MagneticTrance	4/4	4	130	○		"8Z Jarrin"
DrPc	Tekno	6095	MB_MagneticTrance	4/4	4	130	○		:
DrPc	Tekno	6096	MC_MagneticTrance	4/4	4	130	○		:
DrPc	Tekno	6097	MD_MagneticTrance	4/4	4	130	○		:
DrPc	Tekno	6098	MA_Electrix	4/4	2	119	○		"Wacko Kit"
DrPc	Tekno	6099	MB_Electrix	4/4	2	119	○		:
DrPc	Tekno	6100	MC_Electrix	4/4	2	119	○		:
DrPc	Tekno	6101	MD_Electrix	4/4	2	119	○		:
DrPc	Tekno	6102	ME_Electrix	4/4	2	119	○		:
DrPc	Tekno	6103	FA_Electrix	4/4	1	119	○		:
DrPc	Tekno	6104	MA_Cool Breakz	4/4	2	116	○		"8Z Tom Heartz"
DrPc	Tekno	6105	MB_Cool Breakz	4/4	2	116	○		:
DrPc	Tekno	6106	MC_Cool Breakz	4/4	2	116	○		:
DrPc	Tekno	6107	FA_Cool Breakz	4/4	2	116	○		:
DrPc	Tekno	6108	FB_Cool Breakz	4/4	2	116	○		:
DrPc	Tekno	6109	FC_Cool Breakz	4/4	2	116	○		:
DrPc	Tekno	6110	MA_8Z EryLoF11	4/4	1	136	○		"8Z Early Lo-Fi"
DrPc	Tekno	6111	MA_8Z EryLoF12	4/4	1	136	○		:
DrPc	Tekno	6112	MA_8Z EryLoF13	4/4	1	136	○		:
DrPc	Tekno	6113	MA_8Z EryLoF14	4/4	1	136	○		:
DrPc	Tekno	6114	MA_8Z EryLoF15	4/4	1	136	○		:
DrPc	Tekno	6115	MA_8Z NoiseXpr1	4/4	4	136	○		"8Z Noise Xpress"
DrPc	Tekno	6116	MA_8Z NoiseXpr2	4/4	4	136	○		:
DrPc	Tekno	6117	MA_8Z NoiseXpr3	4/4	4	136	○		:
DrPc	Tekno	6118	MA_8Z NoiseXpr4	4/4	4	136	○		:
DrPc	Tekno	6119	MA_8Z NoiseXpr5	4/4	4	136	○		:
DrPc	Tekno	6120	MA_8Z ReversBt1	4/4	1	136	○		"8Z Reverse Beatz"
DrPc	Tekno	6121	MA_8Z ReversBt2	4/4	1	136	○		:
DrPc	Tekno	6122	MA_8Z ReversBt3	4/4	1	136	○		:
DrPc	Tekno	6123	MA_8Z ReversBt4	4/4	1	136	○		:
DrPc	Tekno	6124	MA_8Z CrushDnc1	4/4	2	136	○		"8Z Crush Dance"
DrPc	Tekno	6125	MA_8Z CrushDnc2	4/4	2	136	○		:
DrPc	Tekno	6126	MA_8Z CrushDnc3	4/4	4	13			

Arpeggio Type List

Main Category	Sub Category	ARP No.	ARP Name	Time Signature	Length	Original Tempo	Accent	Random SFX	Voice Type
DrPc	House	6137	ME_Dream Dance/Bd5	4/4	4	136	○		"House Kit 1"
DrPc	House	6138	ME_Dream Dance/Hh1	4/4	1	136	○		:
DrPc	House	6139	ME_Dream Dance/Hh2	4/4	4	136	○		:
DrPc	House	6140	ME_Dream Dance/Hh3	4/4	2	136	○		:
DrPc	House	6141	ME_Dream Dance/Hh4	4/4	4	136	○		"Analog T8 Kit"
DrPc	House	6142	ME_Dream Dance/Clp	4/4	4	136	○		"House Kit 1"
DrPc	House	6143	ME_Dream Dance/Pc1	4/4	4	136	○		"Percussion Kit"
DrPc	House	6144	ME_Dream Dance/Pc2	4/4	2	136	○		"Analog T8 Kit"
DrPc	House	6145	ME_Dream Dance/Pc3	4/4	4	136	○		:
DrPc	House	6146	FA_Dream Dance/Sdf	4/4	4	136	○		"House Kit 1"
DrPc	House	6147	MA1_Ibiza	4/4	2	135	○		:
DrPc	House	6148	MB1_Ibiza	4/4	2	135	○		:
DrPc	House	6149	MC1_Ibiza	4/4	2	135	○		:
DrPc	House	6150	MD1_Ibiza	4/4	2	135	○		:
DrPc	House	6151	IA1_Ibiza	4/4	8	135	○		:
DrPc	House	6152	FA1_Ibiza	4/4	1	135	○		:
DrPc	House	6153	FB1_Ibiza	4/4	1	135	○		:
DrPc	House	6154	FC1_Ibiza	4/4	2	135	○		:
DrPc	House	6155	MA2_Ibiza	4/4	2	135	○		"Dry Standard Kit"
DrPc	House	6156	FB2_Ibiza	4/4	1	135	○		"Dry Standard Kit" (PB Range=24)"
DrPc	House	6157	MA_Retro Pop	4/4	1	126	○		"House Kit 1"
DrPc	House	6158	MC_Retro Pop	4/4	2	126	○		:
DrPc	House	6159	FC_Retro Pop	4/4	1	126	○		:
DrPc	House	6160	MA_Euro Teck	4/4	2	140	○		"Tekno Kit"
DrPc	House	6161	MB_Euro Teck	4/4	2	140	○		:
DrPc	House	6162	MC_Euro Teck	4/4	2	140	○		:
DrPc	House	6163	MD_Euro Teck	4/4	2	140	○		:
DrPc	House	6164	ME_Euro Teck	4/4	2	140	○		:
DrPc	House	6165	MA_Disco House	4/4	4	126	○		"Acid Kit"
DrPc	House	6166	MB_Disco House	4/4	4	126	○		:
DrPc	House	6167	MC_Disco House	4/4	4	126	○		:
DrPc	House	6168	FA_Disco House	4/4	1	126	○		:
DrPc	House	6169	FB_Disco House	4/4	1	126	○		:
DrPc	House	6170	FC_Disco House	4/4	1	126	○		:
DrPc	House	6171	BA_Disco House	4/4	1	126	○		:
DrPc	House	6172	MA1_Club House	4/4	1	128	○		"House Kit 1"
DrPc	House	6173	MB1_Club House	4/4	1	128	○		:
DrPc	House	6174	MC1_Club House	4/4	1	128	○		:
DrPc	House	6175	MD1_Club House	4/4	1	128	○		:
DrPc	House	6176	IA1_Club House	4/4	2	128	○		:
DrPc	House	6177	FA1_Club House	4/4	1	128	○		:
DrPc	House	6178	FB1_Club House	4/4	1	128	○		:
DrPc	House	6179	FC1_Club House	4/4	2	128	○		:
DrPc	House	6180	MD2_Club House	4/4	1	128	○		"Hyper Standard Kit"
DrPc	House	6181	IA2_Club House	4/4	1	128	○		"House Kit 1"
DrPc	House	6182	FB2_Club House	4/4	1	128	○		"Hyper Standard Kit"
DrPc	House	6183	MA_House 1	4/4	2	123	○		"Analog T9 Kit"
DrPc	House	6184	MA_House 2	4/4	1	123	○		"Garage Kit"
DrPc	House	6185	MA_House 3	4/4	2	127	○		:
DrPc	House	6186	MA_House 4	4/4	2	130	○		"Hip Hop Kit 3"
DrPc	House	6187	MB_House 4	4/4	2	130	○		:
DrPc	House	6188	MC_House 4	4/4	2	130	○		:
DrPc	House	6189	MA_House 5	4/4	4	120	○		"House Kit 1"
DrPc	House	6190	MB_House 5	4/4	1	120	○		:
DrPc	House	6191	MC_House 5	4/4	1	120	○		:
DrPc	House	6192	MD_House 5	4/4	1	120	○		:
DrPc	House	6193	MA_House 6	4/4	1	120	○		:
DrPc	House	6194	MB_House 6	4/4	1	120	○		:
DrPc	House	6195	MC_House 6	4/4	1	120	○		:
DrPc	House	6196	MA_House 7	4/4	1	120	○		:
DrPc	House	6197	MB_House 7	4/4	1	120	○		:
DrPc	House	6198	MA_House 8	4/4	2	120	○		:
DrPc	House	6199	MA_House 9	4/4	4	120	○		:
DrPc	House	6200	MA_House 10	4/4	1	120	○		:
DrPc	House	6201	MB_House 10	4/4	1	120	○		:
DrPc	House	6202	MA_House 11	4/4	1	120	○		:
DrPc	House	6203	MB_House 11	4/4	1	120	○		:
DrPc	House	6204	MC_House 11	4/4	1	120	○		:
DrPc	House	6205	MA_House 12	4/4	2	120	○		:
DrPc	House	6206	MA_House 13	4/4	2	120	○		:
DrPc	House	6207	MA_House 14	4/4	1	123	○		:
DrPc	House	6208	MA_House 15	4/4	2	128	○		:
DrPc	House	6209	MA_Garage 1	4/4	2	130	○		"Garage Kit"
DrPc	House	6210	MA_Garage 2	4/4	2	127	○		"House Kit 1"
DrPc	House	6211	MB_Garage 2	4/4	2	127	○		:
DrPc	House	6212	MC_Garage 2	4/4	2	127	○		:
DrPc	House	6213	MD_Garage 2	4/4	2	127	○		:
DrPc	House	6214	IA_Garage 2/a	4/4	1	127	○		:
DrPc	House	6215	IA_Garage 2/b	4/4	1	127	○		:
DrPc	House	6216	FA_Garage 2	4/4	1	127	○		:
DrPc	House	6217	FC_Garage 2	4/4	2	127	○		:
DrPc	House	6218	MA_UK Garage 1	4/4	1	135	○		"Garage Kit"
DrPc	House	6219	MA_UK Garage 2	4/4	1	135	○		:

Main Category	Sub Category	ARP No.	ARP Name	Time Signature	Length	Original Tempo	Accent	Random SFX	Voice Type
DrPc	House	6220	MA_UK Garage 3	4/4	1	138	○		"Garage Kit"
DrPc	House	6221	MA_UK Garage 4	4/4	2	138	○		:
DrPc	House	6222	MA_UK Garage 5	4/4	1	138	○		:
DrPc	House	6223	MA_UK Garage 6	4/4	4	130	○		"House Kit 1"
DrPc	House	6224	MB_UK Garage 6	4/4	4	130	○		:
DrPc	House	6225	MC_UK Garage 6	4/4	4	130	○		:
DrPc	House	6226	MA_2 Step	4/4	2	120	○		:
DrPc	D&B	6227	MA_Big Beat 1	4/4	4	115	○		"Break Kit"
DrPc	D&B	6228	MB_Big Beat 1	4/4	4	115	○		:
DrPc	D&B	6229	MC_Big Beat 1	4/4	4	115	○		:
DrPc	D&B	6230	FA_Big Beat 1	4/4	1	115	○		:
DrPc	D&B	6231	FB_Big Beat 1	4/4	1	115	○		:
DrPc	D&B	6232	FC_Big Beat 1	4/4	1	115	○		:
DrPc	D&B	6233	BA_Big Beat 1	4/4	1	115	○		:
DrPc	D&B	6234	MA1_Big Beat 2	4/4	4	145	○		:
DrPc	D&B	6235	MB1_Big Beat 2	4/4	8	145	○		:
DrPc	D&B	6236	MC1_Big Beat 2	4/4	4	145	○		:
DrPc	D&B	6237	FA1_Big Beat 2	4/4	1	145	○		:
DrPc	D&B	6238	FB1_Big Beat 2	4/4	1	145	○		:
DrPc	D&B	6239	FC1_Big Beat 2	4/4	1	145	○		:
DrPc	D&B	6240	BA1_Big Beat 2	4/4	2	145	○		:
DrPc	D&B	6241	MA2_Big Beat 2	4/4	4	145	○		"Trance Kit"
DrPc	D&B	6242	MB2_Big Beat 2	4/4	8	145	○		:
DrPc	D&B	6243	MC2_Big Beat 2	4/4	4	145	○		:
DrPc	D&B	6244	FA2_Big Beat 2	4/4	1	145	○		:
DrPc	D&B	6245	FB2_Big Beat 2	4/4	1	145	○		:
DrPc	D&B	6246	FC2_Big Beat 2	4/4	1	145	○		:
DrPc	D&B	6247	BA2_Big Beat 2	4/4	2	145	○		:
DrPc	D&B	6248	MA_Big Beat 3	4/4	2	120	○		"Big Kit"
DrPc	D&B	6249	MB_Big Beat 3	4/4	1	120	○		:
DrPc	D&B	6250	MA_Big Beat 4	4/4	1	138	○		:
DrPc	D&B	6251	MA_Big Beat 5	4/4	1	128	○		:
DrPc	D&B	6252	MA_Big Beat 6	4/4	4	120	○		"Rock Stereo Kit 2"
DrPc	D&B	6253	MA_Big Beat 7	4/4	4	136	○		"Big Kit"
DrPc	D&B	6254	MA_Big Beat 8	4/4	1	135	○		:
DrPc	D&B	6255	MA_Big Beat 9	4/4	1	132	○		:
DrPc	D&B	6256	MA_Big Beat 10	4/4	2	124	○		:
DrPc	D&B	6257	MA_Big Beat 11	4/4	1	120	○		:
DrPc	D&B	6258	MA_Break Trance	4/4	1	130	○		"Tekno Kit"
DrPc	D&B	6259	MA1_Breakbeats 1	4/4	4	115	○		"Break Kit"
DrPc	D&B	6260	MB1_Breakbeats 1	4/4	4	115	○		:
DrPc	D&B	6261	MC1_Breakbeats 1	4/4	2	115	○		:
DrPc	D&B	6262	FA1_Breakbeats 1	4/4	1	115	○		:
DrPc	D&B	6263	FB1_Breakbeats 1	4/4	1	115	○		:
DrPc	D&B	6264	FC1_Breakbeats 1	4/4	1	115	○		:
DrPc	D&B	6265	BA1_Breakbeats 1	4/4	1	115	○		:
DrPc	D&B	6266	MA2_8Z Breakbt1	4/4	4	115	○		"8Z Jarrin"
DrPc	D&B	6267	MB2_8Z Breakbt1	4/4	4	115	○		:
DrPc	D&B	6268	MC2_8Z Breakbt1	4/4	2	115	○		:
DrPc	D&B	6269	FA2_8Z Breakbt1	4/4	1	115	○		:
DrPc	D&B	6270	FB2_8Z Breakbt1	4/4	1	115	○		:
DrPc	D&B	6271	FC2_8Z Breakbt1	4/4	1	115	○		:
DrPc	D&B	6272	BA2_8Z Breakbt1	4/4	1	115	○		:
DrPc	D&B	6273	MA1_Breakbeats 2	4/4	4	88	○		"Drum'n'Bass Kit"
DrPc	D&B	6274	MB1_Breakbeats 2	4/4	4	88	○		:
DrPc	D&B	6275	MC1_Breakbeats 2	4/4	4	88	○		:
DrPc	D&B	6276	FA1_Breakbeats 2	4/4	1	88	○		:
DrPc	D&B	6277	FB1_Breakbeats 2	4/4	1	88	○		:
DrPc	D&B	6278	FC1_Breakbeats 2	4/4	1	88	○		:
DrPc	D&B	6279	BA1_Breakbeats 2	4/4	1	88	○		:
DrPc	D&B	6280	MA2_Breakbeats 2	4/4	4	88	○		"Big Kit"
DrPc	D&B	6281	MB2_Breakbeats 2	4/4	4	88	○		:
DrPc	D&B	6282	MC2_Breakbeats 2	4/4	4	88	○		:
DrPc	D&B	6283	FA2_Breakbeats 2	4/4	1	88	○		:
DrPc	D&B	6284	FB2_Breakbeats 2	4/4	1	88	○		:
DrPc	D&B	6285	FC2_Breakbeats 2	4/4	1	88	○		:
DrPc	D&B	6286	BA2_Breakbeats 2	4/4	1	88	○		:
DrPc	D&B	6287	MA_Lo Beat 1	4/4	2	140	○		"Break Kit"
DrPc	D&B	6288	MA_Lo Beat 2	4/4	2	130	○		:
DrPc	D&B	6289	MA_Lo Beat 3	4/4	1	122	○		:
DrPc	D&B	6290	MA_Lo Beat 4	4/4	1	115	○		:
DrPc	D&B	6291	MA_Lo Beat 5	4/4	4	180	○		:
DrPc	D&B	6292	MA_Lo Beat 6	4/4	1	87	○		:
DrPc	D&B	6293	MA_Abstract	4/4	2	86	○		"Hip Hop Kit

Arpeggio Type List

Main Category	Sub Category	ARP No.	ARP Name	Time Signature	Length	Original Tempo	Accent	Random SFX	Voice Type
DrPc	Chill	6303	MB_Ambient 1	4/4	4	102	○		"Break Kit"
DrPc	Chill	6304	MC_Ambient 1	4/4	4	102	○		:
DrPc	Chill	6305	FA_Ambient 1	4/4	1	102	○		:
DrPc	Chill	6306	FB_Ambient 1	4/4	1	102	○		:
DrPc	Chill	6307	FC_Ambient 1	4/4	1	102	○		:
DrPc	Chill	6308	BA_Ambient 1	4/4	1	102	○		:
DrPc	Chill	6309	MA_Ambient 2	4/4	4	111	○		"Belly Dance Kit"
DrPc	Chill	6310	MB_Ambient 2	4/4	2	111	○		:
DrPc	Chill	6311	MC_Ambient 2	4/4	4	111	○		:
DrPc	Chill	6312	FA_Ambient 2	4/4	1	111	○		:
DrPc	Chill	6313	FB_Ambient 2	4/4	8	111	○		:
DrPc	Chill	6314	FC_Ambient 2	4/4	1	111	○		:
DrPc	Chill	6315	BA_Ambient 2	4/4	2	111	○		:
DrPc	Chill	6316	MA1_Ambient 3	4/4	4	88	○		"Hard Kit"
DrPc	Chill	6317	MB1_Ambient 3	4/4	4	88	○		:
DrPc	Chill	6318	MC1_Ambient 3	4/4	4	88	○		:
DrPc	Chill	6319	FA1_Ambient 3	4/4	1	88	○		:
DrPc	Chill	6320	FB1_Ambient 3	4/4	1	88	○		:
DrPc	Chill	6321	FC1_Ambient 3	4/4	1	88	○		:
DrPc	Chill	6322	BA1_Ambient 3	4/4	1	88	○		:
DrPc	Chill	6323	MA2_Ambient 3	4/4	4	88	○		"SFX Kit"
DrPc	Chill	6324	MB2_Ambient 3	4/4	4	88	○		:
DrPc	Chill	6325	MC2_Ambient 3	4/4	4	88	○		:
DrPc	Chill	6326	FA2_Ambient 3	4/4	1	88	○		:
DrPc	Chill	6327	FB2_Ambient 3	4/4	1	88	○		:
DrPc	Chill	6328	FC2_Ambient 3	4/4	1	88	○		:
DrPc	Chill	6329	BA2_Ambient 3	4/4	1	88	○		:
DrPc	Chill	6330	MA3_Ambient 3	4/4	4	88	○		"Pop Latin Kit"
DrPc	Chill	6331	MB3_Ambient 3	4/4	4	88	○		:
DrPc	Chill	6332	MC3_Ambient 3	4/4	4	88	○		:
DrPc	Chill	6333	FA3_Ambient 3	4/4	1	88	○		:
DrPc	Chill	6334	FB3_Ambient 3	4/4	1	88	○		:
DrPc	Chill	6335	FC3_Ambient 3	4/4	1	88	○		:
DrPc	Chill	6336	BA3_Ambient 3	4/4	1	88	○		:
DrPc	Chill	6337	MA1_Chill Out	4/4	2	79	○		"Dry Standard Kit"
DrPc	Chill	6338	MB1_Chill Out	4/4	2	79	○		:
DrPc	Chill	6339	MC1_Chill Out	4/4	4	79	○		:
DrPc	Chill	6340	MD1_Chill Out	4/4	2	79	○		:
DrPc	Chill	6341	IA1_Chill Out	4/4	1	79	○		:
DrPc	Chill	6342	FA1_Chill Out	4/4	1	79	○		:
DrPc	Chill	6343	FB1_Chill Out	4/4	1	79	○		:
DrPc	Chill	6344	FC1_Chill Out	4/4	4	79	○		:
DrPc	Chill	6345	MA2_Chill Out	4/4	2	79	○		"Break Kit"
DrPc	Chill	6346	MB2_Chill Out	4/4	2	79	○		:
DrPc	Chill	6347	MC2_Chill Out	4/4	4	79	○		:
DrPc	Chill	6348	MD2_Chill Out	4/4	2	79	○		:
DrPc	Chill	6349	IA2_Chill Out	4/4	4	79	○		:
DrPc	Chill	6350	FA2_Chill Out	4/4	1	79	○		:
DrPc	Chill	6351	FB2_Chill Out	4/4	1	79	○		:
DrPc	Chill	6352	FC2_Chill Out	4/4	4	79	○		:
DrPc	Chill	6353	MA_ChillKit1 /1	4/4	4	85	○		"Chill Out Kit"
DrPc	Chill	6354	MA_ChillKit1 /2	4/4	4	85	○		:
DrPc	Chill	6355	MA_ChillKit1 /3	4/4	4	85	○		:
DrPc	Chill	6356	MA_ChillKit1 /4	4/4	4	85	○		:
DrPc	Chill	6357	MA_ChillKit1 /5	4/4	4	85	○		:
DrPc	Chill	6358	MA_ChillKit2 /1	4/4	4	85	○		:
DrPc	Chill	6359	MA_ChillKit2 /2	4/4	4	85	○		:
DrPc	Chill	6360	MA_ChillKit2 /3	4/4	4	85	○		:
DrPc	Chill	6361	MA_ChillKit2 /4	4/4	4	85	○		:
DrPc	Chill	6362	MA_ChilOutBreak1	4/4	4	85	○		:
DrPc	Chill	6363	MA_ChilOutBreak2	4/4	4	85	○		:
DrPc	Chill	6364	MA_ChilOutBreak3	4/4	4	85	○		:
DrPc	Chill	6365	MA_ChilOutBreak4	4/4	4	85	○		:
DrPc	Chill	6366	MA_8Z ChillBrk1	4/4	4	85	○		"8Z Chilly Break"
DrPc	Chill	6367	MA_8Z ChillBrk2	4/4	4	85	○		:
DrPc	Chill	6368	MA_8Z ChillBrk3	4/4	4	85	○		:
DrPc	Chill	6369	MA_8Z ChillBrk4	4/4	4	85	○		:
DrPc	Chill	6370	MA_8Z ChillBrk5	4/4	4	85	○		:
DrPc	Chill	6371	MA_ClassicAmbi1	4/4	8	85	○		"Chill Out Kit"
DrPc	Chill	6372	MA_ClassicAmbi2	4/4	1	85	○		:
DrPc	Chill	6373	MA_ChillOutSoft	4/4	1	85	○		:
DrPc	Chill	6374	MA_ChillOutHard	4/4	2	85	○		:
DrPc	Chill	6375	MA_Pop Breaks 1	4/4	2	90	○		:
DrPc	Chill	6376	MA_8Z PopBreak2	4/4	4	90	○		"8Z Glitch"
DrPc	Chill	6377	MA_8Z PopBreak3	4/4	4	90	○		:
DrPc	Chill	6378	MA_8Z GatedBt1	4/4	4	85	○		"8Z Gated Beatz"
DrPc	Chill	6379	MA_8Z GatedBt2	4/4	4	85	○		:
DrPc	Chill	6380	MA_8Z GatedBt3	4/4	4	85	○		:
DrPc	Chill	6381	MA_8Z GatedBt4	4/4	4	85	○		:
DrPc	Chill	6382	MA_8Z GatedBt5	4/4	4	85	○		:
DrPc	Chill	6383	MA_8Z HeavyHrt1	4/4	4	85	○		"8Z Heavy Hearts"
DrPc	Chill	6384	MA_8Z HeavyHrt2	4/4	4	85	○		:
DrPc	Chill	6385	MA_8Z HeavyHrt3	4/4	4	85	○		:

Main Category	Sub Category	ARP No.	ARP Name	Time Signature	Length	Original Tempo	Accent	Random SFX	Voice Type
DrPc	Chill	6386	MA_8Z HeavyHrt4	4/4	4	85	○		"8Z Heavy Hearts"
DrPc	Chill	6387	MA_8Z HeavyHrt5	4/4	4	85	○		:
DrPc	Chill	6388	MA1_Synth Pop1	4/4	4	90	○		"House Kit 1"
DrPc	Chill	6389	MB1_Synth Pop1	4/4	4	90	○		:
DrPc	Chill	6390	MC1_Synth Pop1	4/4	4	90	○		:
DrPc	Chill	6391	MD1_Synth Pop1	4/4	4	90	○		:
DrPc	Chill	6392	FC1_Synth Pop1	4/4	4	90	○		:
DrPc	Chill	6393	MC2_Synth Pop1	4/4	2	90	○		:
DrPc	Chill	6394	MD2_Synth Pop1	4/4	2	90	○		:
DrPc	Chill	6395	FC2_Synth Pop1	4/4	4	90	○		:
DrPc	Chill	6396	ME3_Synth Pop1	4/4	2	90	○		"Hip Hop Kit 3"
DrPc	Chill	6397	ME4_Synth Pop1	4/4	2	90	○		"House Kit 1"
DrPc	Chill	6398	MA_Synth Pop2	4/4	2	90	○		"Synth Pop Kit"
DrPc	Chill	6399	MB_Synth Pop2	4/4	2	90	○		:
DrPc	Chill	6400	MC_Synth Pop2	4/4	2	90	○		:
DrPc	Chill	6401	MD_Synth Pop2	4/4	2	90	○		:
DrPc	Chill	6402	ME_Synth Pop2	4/4	2	90	○		:
DrPc	Chill	6403	MA_8Z Static	4/4	2	90	○		"8Z Static"
DrPc	Chill	6404	MB_8Z Static	4/4	2	90	○		:
DrPc	Chill	6405	MC_8Z Static	4/4	2	90	○		:
DrPc	Chill	6406	MD_8Z Static	4/4	2	90	○		:
DrPc	Chill	6407	BA_8Z Static	4/4	1	90	○		:
DrPc	Chill	6408	BB_8Z Static	4/4	1	90	○		:
DrPc	Jazz	6409	MA_AcousticJazz	4/4	4	204	○		"Dry Standard Kit"
DrPc	Jazz	6410	MB_AcousticJazz	4/4	4	204	○		:
DrPc	Jazz	6411	MC_AcousticJazz	4/4	4	204	○		:
DrPc	Jazz	6412	MD_AcousticJazz	4/4	4	204	○		:
DrPc	Jazz	6413	IA_AcousticJazz	4/4	4	204	○		:
DrPc	Jazz	6414	FA_AcousticJazz	4/4	1	204	○		:
DrPc	Jazz	6415	FB_AcousticJazz	4/4	1	204	○		:
DrPc	Jazz	6416	FC_AcousticJazz	4/4	4	204	○		:
DrPc	Jazz	6417	MA1_Modern Jazz	4/4	16	218	○		"Power Standard Kit 1"
DrPc	Jazz	6418	MB1_Modern Jazz	4/4	16	218	○		:
DrPc	Jazz	6419	MC1_Modern Jazz	4/4	16	218	○		:
DrPc	Jazz	6420	FA1_Modern Jazz	4/4	1	218	○		:
DrPc	Jazz	6421	FB1_Modern Jazz	4/4	1	218	○		:
DrPc	Jazz	6422	FC1_Modern Jazz	4/4	1	218	○		:
DrPc	Jazz	6423	BA1_Modern Jazz	4/4	1	218	○		:
DrPc	Jazz	6424	EA1_Modern Jazz	4/4	6	218	○		:
DrPc	Jazz	6425	EB1_Modern Jazz	4/4	7	218	○		:
DrPc	Jazz	6426	MA2_Modern Jazz	4/4	16	218	○		"Pop Latin Kit"
DrPc	Jazz	6427	MB2_Modern Jazz	4/4	16	218	○		:
DrPc	Jazz	6428	MC2_Modern Jazz	4/4	16	218	○		:
DrPc	Jazz	6429	FA2_Modern Jazz	4/4	1	218	○		:
DrPc	Jazz	6430	FB2_Modern Jazz	4/4	1	218	○		:
DrPc	Jazz	6431	FC2_Modern Jazz	4/4	1	218	○		:
DrPc	Jazz	6432	BA2_Modern Jazz	4/4	1	218	○		:
DrPc	Jazz	6433	EA2_Modern Jazz	4/4	6	218	○		:
DrPc	Jazz	6434	EB2_Modern Jazz	4/4	7	218	○		:
DrPc	Jazz	6435	MA_JazzGtrClub	4/4	8	142	○		"Brush Kit"
DrPc	Jazz	6436	MB_JazzGtrClub	4/4	8	142	○		:
DrPc	Jazz	6437	MC_JazzGtrClub	4/4	8	142	○		:
DrPc	Jazz	6438	FA_JazzGtrClub	4/4	1	142	○		:
DrPc	Jazz	6439	FB_JazzGtrClub	4/4	1	142	○		:
DrPc	Jazz	6440	FC_JazzGtrClub	4/4	1	142	○		:
DrPc	Jazz	6441	BA_JazzGtrClub	4/4	1	142	○		:
DrPc	Jazz	6442	EA_JazzGtrClub	4/4	6	142	○		:
DrPc	Jazz	6443	MA_Bebop	4/4	4	152	○		"Dry Standard Kit"
DrPc	Jazz	6444	MB_Bebop	4/4	4	152	○		:
DrPc	Jazz	6445	MA_JazzWaltzMed	3/4	8	180	○		"Power Standard Kit 1"
DrPc	Jazz	6446	MB_JazzWaltzMed	3/4	8	180	○		:
DrPc	Jazz	6447	MC_JazzWaltzMed	3/4	8	180	○		:
DrPc	Jazz	6448	FA_JazzWaltzMed	3/4	1	180	○		:
DrPc	Jazz	6449	FB_JazzWaltzMed	3/4	1	180	○		:
DrPc	Jazz	6450	FC_JazzWaltzMed	3/4	1	180	○		:
DrPc	Jazz	6451	BA_JazzWaltzMed	3/4	1	180	○		:
DrPc	Jazz	6452	EA_JazzWaltzMed	3/4	7	180	○		:
DrPc	Jazz	6453	MA_R&R Shuffle	4/4	4	192	○		:
DrPc	Jazz	6454	MB_R&R Shuffle	4/4	4	192	○		:
DrPc	Jazz	6455	MC_R&R Shuffle	4/4	4	192	○		:
DrPc	Jazz	6456	FA_R&R Shuffle	4/4	1	192	○		:
DrPc	Jazz	6457	FB_R&R Shuffle	4/4	1	192	○		:
DrPc	Jazz	6458	FC_R&R Shuffle	4/4	1	192	○		:
DrPc	Jazz	6459	BA_R&R Shuffle	4/4	1	192	○		:
DrPc	Jazz	6460	EA_R&R Shuffle	4/4	5	192	○		:
DrPc	Jazz	6461	EB_R&R Shuffle	4/4	5	192			

Arpeggio Type List

Main Category	Sub Category	ARP No.	ARP Name	Time Signature	Length	Original Tempo	Accent	Random SFX	Voice Type
DrPc	Jazz	6469	EA_ShuffleBlues	4/4	5	115	○		*Power Standard Kit 2*
DrPc	Jazz	6470	EB_ShuffleBlues	4/4	6	115	○		:
DrPc	Jazz	6471	MA_Slow Blues 1	4/4	2	49	○		:
DrPc	Jazz	6472	MB_Slow Blues 1	4/4	2	49	○		:
DrPc	Jazz	6473	MC_Slow Blues 1	4/4	2	49	○		:
DrPc	Jazz	6474	FA_Slow Blues 1	4/4	1	49	○		:
DrPc	Jazz	6475	FB_Slow Blues 1	4/4	1	49	○		:
DrPc	Jazz	6476	FC_Slow Blues 1	4/4	1	49	○		:
DrPc	Jazz	6477	BA_Slow Blues 1	4/4	1	49	○		:
DrPc	Jazz	6478	EA_Slow Blues 1	4/4	3	49	○		:
DrPc	Jazz	6479	EB_Slow Blues 1	4/4	3	49	○		:
DrPc	Jazz	6480	MA_Slow Blues 2	4/4	4	72	○		*Modern Rock Kit*
DrPc	Jazz	6481	MB_Slow Blues 2	4/4	4	72	○		:
DrPc	Jazz	6482	MC_Slow Blues 2	4/4	4	72	○		:
DrPc	Jazz	6483	FA_Slow Blues 2	4/4	1	72	○		:
DrPc	Jazz	6484	FB_Slow Blues 2	4/4	1	72	○		:
DrPc	Jazz	6485	FC_Slow Blues 2	4/4	1	72	○		:
DrPc	Jazz	6486	BA_Slow Blues 2	4/4	1	72	○		:
DrPc	Jazz	6487	MA_Piano Boogie	4/4	8	160	○		*Power Standard Kit 2*
DrPc	Jazz	6488	MB_Piano Boogie	4/4	4	160	○		:
DrPc	Jazz	6489	MC_Piano Boogie	4/4	4	160	○		:
DrPc	Jazz	6490	FA_Piano Boogie	4/4	1	160	○		:
DrPc	Jazz	6491	FB_Piano Boogie	4/4	1	160	○		:
DrPc	Jazz	6492	FC_Piano Boogie	4/4	1	160	○		:
DrPc	Jazz	6493	BA_Piano Boogie	4/4	1	160	○		:
DrPc	Jazz	6494	EA_Piano Boogie	4/4	5	160	○		:
DrPc	Jazz	6495	EB_Piano Boogie	4/4	5	160	○		:
DrPc	Latin	6496	MA1_Salsa 1	4/4	4	177	○		*Power Standard Kit 1*
DrPc	Latin	6497	MB1_Salsa 1	4/4	4	177	○		:
DrPc	Latin	6498	MC1_Salsa 1	4/4	4	177	○		:
DrPc	Latin	6499	FA1_Salsa 1	4/4	1	177	○		:
DrPc	Latin	6500	FB1_Salsa 1	4/4	1	177	○		:
DrPc	Latin	6501	FC1_Salsa 1	4/4	1	177	○		:
DrPc	Latin	6502	BA1_Salsa 1	4/4	1	177	○		:
DrPc	Latin	6503	EA1_Salsa 1	4/4	5	177	○		:
DrPc	Latin	6504	EB1_Salsa 1	4/4	5	177	○		:
DrPc	Latin	6505	MA2_Salsa 1	4/4	4	177	○		*Pop Latin Kit*
DrPc	Latin	6506	MB2_Salsa 1	4/4	4	177	○		:
DrPc	Latin	6507	MC2_Salsa 1	4/4	4	177	○		:
DrPc	Latin	6508	FA2_Salsa 1	4/4	1	177	○		:
DrPc	Latin	6509	FB2_Salsa 1	4/4	1	177	○		:
DrPc	Latin	6510	FC2_Salsa 1	4/4	1	177	○		:
DrPc	Latin	6511	BA2_Salsa 1	4/4	1	177	○		:
DrPc	Latin	6512	EA2_Salsa 1	4/4	5	177	○		:
DrPc	Latin	6513	EB2_Salsa 1	4/4	5	177	○		:
DrPc	Latin	6514	MA1_Salsa 2	4/4	2	123	○		*Dry Standard Kit*
DrPc	Latin	6515	MB1_Salsa 2	4/4	2	123	○		:
DrPc	Latin	6516	MC1_Salsa 2	4/4	2	123	○		:
DrPc	Latin	6517	MD1_Salsa 2	4/4	4	123	○		:
DrPc	Latin	6518	IA1_Salsa 2/a	4/4	2	123	○		:
DrPc	Latin	6519	IA1_Salsa 2/b	4/4	2	123	○		:
DrPc	Latin	6520	FA1_Salsa 2	4/4	1	123	○		:
DrPc	Latin	6521	FB1_Salsa 2	4/4	1	123	○		:
DrPc	Latin	6522	FC1_Salsa 2	4/4	2	123	○		:
DrPc	Latin	6523	MA2_Salsa 2	4/4	4	123	○		*Pop Latin Kit*
DrPc	Latin	6524	MB2_Salsa 2	4/4	4	123	○		:
DrPc	Latin	6525	MC2_Salsa 2	4/4	4	123	○		:
DrPc	Latin	6526	MD2_Salsa 2	4/4	4	123	○		:
DrPc	Latin	6527	IA2_Salsa 2	4/4	4	123	○		:
DrPc	Latin	6528	FA2_Salsa 2	4/4	1	123	○		:
DrPc	Latin	6529	FB2_Salsa 2	4/4	1	123	○		:
DrPc	Latin	6530	FC2_Salsa 2	4/4	2	123	○		:
DrPc	Latin	6531	MA1_AfroCuban	4/4	4	200	○		*Power Standard Kit 1*
DrPc	Latin	6532	MB1_AfroCuban	4/4	4	200	○		:
DrPc	Latin	6533	MC1_AfroCuban	4/4	4	200	○		:
DrPc	Latin	6534	FA1_AfroCuban	4/4	1	200	○		:
DrPc	Latin	6535	FB1_AfroCuban	4/4	1	200	○		:
DrPc	Latin	6536	FC1_AfroCuban	4/4	1	200	○		:
DrPc	Latin	6537	BA1_AfroCuban	4/4	1	200	○		:
DrPc	Latin	6538	EA1_AfroCuban	4/4	6	200	○		:
DrPc	Latin	6539	EB1_AfroCuban	4/4	5	200	○		:
DrPc	Latin	6540	MA2_AfroCuban	4/4	4	200	○		*Pop Latin Kit*
DrPc	Latin	6541	MB2_AfroCuban	4/4	4	200	○		:
DrPc	Latin	6542	MC2_AfroCuban	4/4	4	200	○		:
DrPc	Latin	6543	FA2_AfroCuban	4/4	1	200	○		:
DrPc	Latin	6544	FB2_AfroCuban	4/4	1	200	○		:
DrPc	Latin	6545	FC2_AfroCuban	4/4	1	200	○		:
DrPc	Latin	6546	BA2_AfroCuban	4/4	1	200	○		:
DrPc	Latin	6547	EA2_AfroCuban	4/4	6	200	○		:
DrPc	Latin	6548	EB2_AfroCuban	4/4	5	200	○		:
DrPc	Latin	6549	MA1_Montuno	4/4	2	100	○		*Dry Standard Kit*
DrPc	Latin	6550	MB1_Montuno	4/4	2	100	○		:
DrPc	Latin	6551	MC1_Montuno	4/4	2	100	○		:

Main Category	Sub Category	ARP No.	ARP Name	Time Signature	Length	Original Tempo	Accent	Random SFX	Voice Type
DrPc	Latin	6552	MD1_Montuno	4/4	2	100	○		*Dry Standard Kit*
DrPc	Latin	6553	IA1_Montuno	4/4	2	100	○		:
DrPc	Latin	6554	FA1_Montuno	4/4	1	100	○		:
DrPc	Latin	6555	FB1_Montuno	4/4	1	100	○		:
DrPc	Latin	6556	FC1_Montuno	4/4	2	100	○		:
DrPc	Latin	6557	MA2_Montuno	4/4	4	100	○		*Latin Percussion Kit*
DrPc	Latin	6558	MB2_Montuno	4/4	4	100	○		:
DrPc	Latin	6559	MC2_Montuno	4/4	4	100	○		:
DrPc	Latin	6560	MD2_Montuno	4/4	4	100	○		:
DrPc	Latin	6561	IA2_Montuno	4/4	4	100	○		:
DrPc	Latin	6562	FA2_Montuno	4/4	1	100	○		:
DrPc	Latin	6563	FB2_Montuno	4/4	1	100	○		:
DrPc	Latin	6564	FC2_Montuno	4/4	4	100	○		:
DrPc	Latin	6565	MA1_Brazil Samba	4/4	4	96	○		*Power Standard Kit 1*
DrPc	Latin	6566	MB1_Brazil Samba	4/4	4	96	○		:
DrPc	Latin	6567	MC1_Brazil Samba	4/4	4	96	○		:
DrPc	Latin	6568	FA1_Brazil Samba	4/4	1	96	○		:
DrPc	Latin	6569	FB1_Brazil Samba	4/4	1	96	○		:
DrPc	Latin	6570	FC1_Brazil Samba	4/4	1	96	○		:
DrPc	Latin	6571	BA1_Brazil Samba	4/4	1	96	○		:
DrPc	Latin	6572	EA1_Brazil Samba	4/4	4	96	○		:
DrPc	Latin	6573	EB1_Brazil Samba	4/4	4	96	○		:
DrPc	Latin	6574	MA2_Brazil Samba	4/4	4	96	○		*Pop Latin Kit*
DrPc	Latin	6575	MB2_Brazil Samba	4/4	4	96	○		:
DrPc	Latin	6576	MC2_Brazil Samba	4/4	4	96	○		:
DrPc	Latin	6577	FA2_Brazil Samba	4/4	1	96	○		:
DrPc	Latin	6578	FB2_Brazil Samba	4/4	1	96	○		:
DrPc	Latin	6579	FC2_Brazil Samba	4/4	1	96	○		:
DrPc	Latin	6580	BA2_Brazil Samba	4/4	1	96	○		:
DrPc	Latin	6581	EA2_Brazil Samba	4/4	4	96	○		:
DrPc	Latin	6582	EB2_Brazil Samba	4/4	4	96	○		:
DrPc	Latin	6583	MA_Samba	4/4	4	120	○		*Dry Standard Kit*
DrPc	Latin	6584	MB_Samba	4/4	4	120	○		:
DrPc	Latin	6585	MC_Samba	4/4	4	120	○		:
DrPc	Latin	6586	MD_Samba	4/4	4	120	○		:
DrPc	Latin	6587	IA_Samba	4/4	2	120	○		:
DrPc	Latin	6588	FA_Samba	4/4	1	120	○		:
DrPc	Latin	6589	FB_Samba	4/4	1	120	○		:
DrPc	Latin	6590	FC_Samba	4/4	2	120	○		:
DrPc	Latin	6591	MA_Bomba	4/4	4	99	○		*Pop Latin Kit*
DrPc	Latin	6592	MB_Bomba	4/4	4	99	○		:
DrPc	Latin	6593	MC_Bomba	4/4	4	99	○		:
DrPc	Latin	6594	FA_Bomba	4/4	1	99	○		:
DrPc	Latin	6595	FB_Bomba	4/4	1	99	○		:
DrPc	Latin	6596	FC_Bomba	4/4	1	99	○		:
DrPc	Latin	6597	BA_Bomba	4/4	1	99	○		:
DrPc	Latin	6598	EA_Bomba	4/4	3	99	○		:
DrPc	Latin	6599	EB_Bomba	4/4	3	99	○		:
DrPc	Latin	6600	MA1_Bossa	4/4	4	124	○		*Brush Kit*
DrPc	Latin	6601	MB1_Bossa	4/4	4	124	○		:
DrPc	Latin	6602	MC1_Bossa	4/4	4	124	○		:
DrPc	Latin	6603	FA1_Bossa	4/4	1	124	○		:
DrPc	Latin	6604	FB1_Bossa	4/4	1	124	○		:
DrPc	Latin	6605	FC1_Bossa	4/4	1	124	○		:
DrPc	Latin	6606	BA1_Bossa	4/4	1	124	○		:
DrPc	Latin	6607	EA1_Bossa	4/4	4	123	○		:
DrPc	Latin	6608	EB1_Bossa	4/4	4	123	○		:
DrPc	Latin	6609	MA2_Bossa	4/4	4	124	○		:
DrPc	Latin	6610	MB2_Bossa	4/4	4	124	○		:
DrPc	Latin	6611	MC2_Bossa	4/4	4	124	○		:
DrPc	Latin	6612	FA2_Bossa	4/4	1	124	○		:
DrPc	Latin	6613	FB2_Bossa	4/4	1	124	○		:
DrPc	Latin	6614	FC2_Bossa	4/4	1	124	○		:
DrPc	Latin	6615	BA2_Bossa	4/4	1	124	○		:
DrPc	Latin	6616	EA2_Bossa	4/4	4	123	○		:
DrPc	Latin	6617	EB2_Bossa	4/4	4	123	○		:
DrPc	Latin	6618	MA_Merengue	4/4	4	130	○		*Pop Latin Kit*
DrPc	Latin	6619	MB_Merengue	4/4	4	130	○		:
DrPc	Latin	6620	MC_Merengue	4/4	4	130	○		:
DrPc	Latin	6621	FA_Merengue	4/4	1	130	○		:
DrPc	Latin	6622	FB_Merengue	4/4	1	130	○		:
DrPc	Latin	6623	FC_Merengue	4/4	1	130	○		:
DrPc	Latin	6624	BA_Merengue	4/4	1	130	○		:
DrPc	Latin	6625	EA_Merengue	4/4	3	130	○		:
DrPc	Latin	6626	EB_Merengue	4/4	3	130	○		:
DrPc	Latin	6627	MA_Guaguanco	4/4	4	120	○		:
DrPc	Latin	6628	MB_Guaguanco	4/4	4	120	○		:
DrPc	Latin	6629	MC_Guaguanco	4/4	4	120	○		:
DrPc	Latin	6630	FA_Guaguanco	4/4	1	120	○		:
Dr									

Arpeggio Type List

Main Category	Sub Category	ARP No.	ARP Name	Time Signature	Length	Original Tempo	Accent	Random SFX	Voice Type
DrPc	Latin	6635	EB_Guaguanco	4/4	3	120	○		"Pop Latin Kit"
DrPc	Latin	6636	MA_Latin	4/4	4	120	○		"Latin Percussion Kit"
DrPc	Latin	6637	MB_Latin	4/4	4	120	○		:
DrPc	Latin	6638	MC_Latin	4/4	4	120	○		:
DrPc	Latin	6639	MD_Latin	4/4	4	120	○		:
DrPc	Latin	6640	ME_Latin	4/4	4	120	○		:
DrPc	Latin	6641	MA_Latin Rock	4/4	2	120	○		"Dry Standard Kit"
DrPc	Latin	6642	MB_Latin Rock	4/4	2	120	○		:
DrPc	Latin	6643	MC_Latin Rock	4/4	2	120	○		:
DrPc	Latin	6644	MD_Latin Rock	4/4	4	120	○		:
DrPc	Latin	6645	IA_Latin Rock	4/4	2	120	○		:
DrPc	Latin	6646	FA_Latin Rock	4/4	1	120	○		:
DrPc	Latin	6647	FB_Latin Rock	4/4	1	120	○		:
DrPc	Latin	6648	FC_Latin Rock	4/4	1	120	○		:
DrPc	Latin	6649	MA1_Disco Latin	4/4	4	100	○		:
DrPc	Latin	6650	MB1_Disco Latin	4/4	4	100	○		:
DrPc	Latin	6651	MC1_Disco Latin	4/4	4	100	○		:
DrPc	Latin	6652	FA1_Disco Latin	4/4	1	100	○		:
DrPc	Latin	6653	FB1_Disco Latin	4/4	1	100	○		:
DrPc	Latin	6654	FC1_Disco Latin	4/4	1	100	○		:
DrPc	Latin	6655	BA1_Disco Latin	4/4	1	100	○		:
DrPc	Latin	6656	MA2_Disco Latin	4/4	4	100	○		"Latin Percussion Kit"
DrPc	Latin	6657	MB2_Disco Latin	4/4	4	100	○		:
DrPc	Latin	6658	MC2_Disco Latin	4/4	4	100	○		:
DrPc	Latin	6659	FA2_Disco Latin	4/4	1	100	○		:
DrPc	Latin	6660	FB2_Disco Latin	4/4	1	100	○		:
DrPc	Latin	6661	FC2_Disco Latin	4/4	1	100	○		:
DrPc	Latin	6662	BA2_Disco Latin	4/4	1	100	○		:
DrPc	Latin	6663	MA_Latin House	4/4	4	138	○		"House Kit 1"
DrPc	Latin	6664	FB_Latin House	4/4	4	138	○		:
DrPc	Latin	6665	FC_Latin House	4/4	4	138	○		:
DrPc	World	6666	MA_ReggaeShuffle	4/4	4	90	○		"Power Standard Kit 1"
DrPc	World	6667	MB_ReggaeShuffle	4/4	4	90	○		:
DrPc	World	6668	MC_ReggaeShuffle	4/4	4	90	○		:
DrPc	World	6669	FA_ReggaeShuffle	4/4	1	90	○		:
DrPc	World	6670	FB_ReggaeShuffle	4/4	1	90	○		:
DrPc	World	6671	FC_ReggaeShuffle	4/4	1	90	○		:
DrPc	World	6672	BA_ReggaeShuffle	4/4	1	90	○		:
DrPc	World	6673	EA_ReggaeShuffle	4/4	3	90	○		:
DrPc	World	6674	EB_ReggaeShuffle	4/4	4	90	○		:
DrPc	World	6675	MA_Jumbo Reggae	4/4	4	100	○		"Trance Kit"
DrPc	World	6676	MB_Jumbo Reggae	4/4	4	100	○		:
DrPc	World	6677	MC_Jumbo Reggae	4/4	4	100	○		:
DrPc	World	6678	FA_Jumbo Reggae	4/4	1	100	○		:
DrPc	World	6679	FB_Jumbo Reggae	4/4	1	100	○		:
DrPc	World	6680	FC_Jumbo Reggae	4/4	1	100	○		:
DrPc	World	6681	BA_Jumbo Reggae	4/4	1	100	○		:
DrPc	World	6682	EA_Jumbo Reggae	4/4	3	100	○		:
DrPc	World	6683	EB_Jumbo Reggae	4/4	3	100	○		:
DrPc	World	6684	MA1_Reggae 1	4/4	4	102	○		"Dry Standard Kit"
DrPc	World	6685	MB1_Reggae 1	4/4	4	102	○		:
DrPc	World	6686	MC1_Reggae 1	4/4	4	80	○		:
DrPc	World	6687	MD1_Reggae 1	4/4	4	90	○		:
DrPc	World	6688	IA1_Reggae 1	4/4	4	102	○		:
DrPc	World	6689	FA1_Reggae 1	4/4	1	96	○		:
DrPc	World	6690	FB1_Reggae 1	4/4	1	102	○		:
DrPc	World	6691	FC1_Reggae 1	4/4	4	96	○		:
DrPc	World	6692	MA2_Reggae 1	4/4	4	102	○		"Percussion Kit"
DrPc	World	6693	MB2_Reggae 1	4/4	4	102	○		:
DrPc	World	6694	MC2_Reggae 1	4/4	4	80	○		:
DrPc	World	6695	MD2_Reggae 1	4/4	4	90	○		:
DrPc	World	6696	IA2_Reggae 1	4/4	4	102	○		:
DrPc	World	6697	FA2_Reggae 1	4/4	4	96	○		:
DrPc	World	6698	MA_Reggae 2	4/4	2	92	○		"Dry Standard Kit"
DrPc	World	6699	MB_Reggae 2	4/4	2	92	○		:
DrPc	World	6700	MC_Reggae 2	4/4	2	92	○		:
DrPc	World	6701	MD_Reggae 2	4/4	2	92	○		:
DrPc	World	6702	IA_Reggae 2/a	4/4	1	92	○		:
DrPc	World	6703	IA_Reggae 2/b	4/4	1	92	○		:
DrPc	World	6704	FA_Reggae 2	4/4	1	92	○		:
DrPc	World	6705	FB_Reggae 2	4/4	1	92	○		:
DrPc	World	6706	FC_Reggae 2	4/4	1	92	○		:
DrPc	World	6707	MA1_RumbaFlamenc	4/4	4	106	○		"Power Standard Kit 1"
DrPc	World	6708	MB1_RumbaFlamenc	4/4	4	106	○		:
DrPc	World	6709	MC1_RumbaFlamenc	4/4	4	106	○		:
DrPc	World	6710	FA1_RumbaFlamenc	4/4	1	106	○		:
DrPc	World	6711	FB1_RumbaFlamenc	4/4	1	106	○		:
DrPc	World	6712	FC1_RumbaFlamenc	4/4	1	106	○		:
DrPc	World	6713	BA1_RumbaFlamenc	4/4	1	106	○		:
DrPc	World	6714	EA1_RumbaFlamenc	4/4	3	106	○		:
DrPc	World	6715	EB1_RumbaFlamenc	4/4	3	106	○		:
DrPc	World	6716	MA2_RumbaFlamenc	4/4	4	106	○		"Pop Latin Kit"
DrPc	World	6717	MB2_RumbaFlamenc	4/4	4	106	○		:

Main Category	Sub Category	ARP No.	ARP Name	Time Signature	Length	Original Tempo	Accent	Random SFX	Voice Type
DrPc	World	6718	MC2_RumbaFlamenc	4/4	4	106	○		"Pop Latin Kit"
DrPc	World	6719	FA2_RumbaFlamenc	4/4	1	106	○		:
DrPc	World	6720	FB2_RumbaFlamenc	4/4	1	106	○		:
DrPc	World	6721	FC2_RumbaFlamenc	4/4	1	106	○		:
DrPc	World	6722	BA2_RumbaFlamenc	4/4	1	106	○		:
DrPc	World	6723	EA2_RumbaFlamenc	4/4	3	106	○		:
DrPc	World	6724	EB2_RumbaFlamenc	4/4	3	106	○		:
DrPc	World	6725	MA_Spanish Pop	4/4	2	120	○		"Hyper Standard Kit"
DrPc	World	6726	MB_Spanish Pop	4/4	2	120	○		:
DrPc	World	6727	MC_Spanish Pop	4/4	2	120	○		:
DrPc	World	6728	MD_Spanish Pop	4/4	2	120	○		:
DrPc	World	6729	MA_ModBluegrass	4/4	4	121	○		"Power Standard Kit 2"
DrPc	World	6730	MB_ModBluegrass	4/4	4	121	○		:
DrPc	World	6731	MC_ModBluegrass	4/4	4	121	○		:
DrPc	World	6732	FA_ModBluegrass	4/4	1	121	○		:
DrPc	World	6733	FB_ModBluegrass	4/4	1	121	○		:
DrPc	World	6734	FC_ModBluegrass	4/4	1	121	○		:
DrPc	World	6735	BA_ModBluegrass	4/4	1	121	○		:
DrPc	World	6736	EA_ModBluegrass	4/4	6	121	○		:
DrPc	World	6737	IA_Spanish Pop/a	4/4	1	120	○		"Hyper Standard Kit"
DrPc	World	6738	IA_Spanish Pop/b	4/4	1	120	○		:
DrPc	World	6739	FA_Spanish Pop	4/4	1	120	○		:
DrPc	World	6740	FB_Spanish Pop	4/4	1	120	○		:
DrPc	World	6741	FC_Spanish Pop	4/4	1	120	○		:
DrPc	World	6742	MA_Irish Hymn	3/4	4	70	○		"Power Standard Kit 2"
DrPc	World	6743	MB_Irish Hymn	3/4	4	70	○		:
DrPc	World	6744	MC_Irish Hymn	3/4	4	70	○		:
DrPc	World	6745	FA_Irish Hymn	3/4	1	70	○		:
DrPc	World	6746	FB_Irish Hymn	3/4	1	70	○		:
DrPc	World	6747	FC_Irish Hymn	3/4	1	70	○		:
DrPc	World	6748	BA_Irish Hymn	3/4	1	70	○		:
DrPc	World	6749	EA_Irish Hymn	3/4	5	70	○		:
DrPc	World	6750	EB_Irish Hymn	3/4	5	70	○		:
DrPc	World	6751	MA1_Turkish Pop	4/4	4	101	○		"Arabic Mixed Kit"
DrPc	World	6752	MB1_Turkish Pop	4/4	4	101	○		:
DrPc	World	6753	MC1_Turkish Pop	4/4	4	101	○		:
DrPc	World	6754	MD1_Turkish Pop	4/4	4	101	○		:
DrPc	World	6755	FA1_Turkish Pop	4/4	1	101	○		:
DrPc	World	6756	FB1_Turkish Pop	4/4	1	101	○		:
DrPc	World	6757	FC1_Turkish Pop	4/4	1	101	○		:
DrPc	World	6758	FD1_Turkish Pop	4/4	1	101	○		:
DrPc	World	6759	MA2_Turkish Pop	4/4	4	101	○		"Hip Hop Kit 1"
DrPc	World	6760	MB2_Turkish Pop	4/4	4	101	○		:
DrPc	World	6761	MC2_Turkish Pop	4/4	4	101	○		:
DrPc	World	6762	MD2_Turkish Pop	4/4	4	101	○		:
DrPc	World	6763	FA2_Turkish Pop	4/4	1	101	○		:
DrPc	World	6764	FB2_Turkish Pop	4/4	1	101	○		:
DrPc	World	6765	FC2_Turkish Pop	4/4	1	101	○		:
DrPc	World	6766	FD2_Turkish Pop	4/4	1	101	○		:
DrPc	World	6767	MA1_TurkishDance	4/4	4	130	○		"Arabic Mixed Kit"
DrPc	World	6768	MB1_TurkishDance	4/4	4	130	○		:
DrPc	World	6769	MC1_TurkishDance	4/4	4	130	○		:
DrPc	World	6770	MD1_TurkishDance	4/4	4	130	○		:
DrPc	World	6771	FA1_TurkishDance	4/4	1	130	○		:
DrPc	World	6772	FB1_TurkishDance	4/4	1	130	○		:
DrPc	World	6773	FC1_TurkishDance	4/4	1	130	○		:
DrPc	World	6774	FD1_TurkishDance	4/4	1	130	○		:
DrPc	World	6775	MA2_TurkishDance	4/4	4	130	○		"Hip Hop Kit 1"
DrPc	World	6776	MB2_TurkishDance	4/4	4	130	○		:
DrPc	World	6777	MC2_TurkishDance	4/4	4	130	○		:
DrPc	World	6778	MD2_TurkishDance	4/4	4	130	○		:
DrPc	World	6779	FA2_TurkishDance	4/4	1	130	○		:
DrPc	World	6780	FB2_TurkishDance	4/4	1	130	○		:
DrPc	World	6781	FC2_TurkishDance	4/4	1	130	○		:
DrPc	World	6782	FD2_TurkishDance	4/4	1	130	○		:
DrPc	World	6783	MA1_Turkish	4/4	2	105	○		"Arabic Mixed Kit"
DrPc	World	6784	MB1_Turkish	4/4	2	105	○		:
DrPc	World	6785	MC1_Turkish	9/8	2	125	○		:
DrPc	World	6786	MD1_Turkish	9/8	2	125	○		:
DrPc	World	6787	FA1_Turkish	4/4	2	105	○		:
DrPc	World	6788	FB1_Turkish	4/4	2	105	○		:
DrPc	World	6789	IA1_Turkish/a	4/4	1	86	○		:
DrPc	World	6790	IA1_Turkish/b	4/4	1	86	○		:
DrPc	World	6791	FA1_Turkish	4/4	1	120	○		:
DrPc	World	6792	MA2_Turkish	4/4	2	105	○		:
DrPc	World	6793	MB2_Turkish	4/4	2	105	○		:
DrPc	World	6794	MC2_Turkish	9/8	2	125	○		:
DrPc	World	6795	MD2_Turkish	9/8	2	125	○		:

Main Category	Sub Category	ARP No.	ARP Name	Time Signature	Length	Original Tempo	Accent	Random SFX	Voice Type
DrPc	World	6801	MA1_TurkishEuro1	4/4	4	112	○		*Arabic Mixed Kit*
DrPc	World	6802	MB1_TurkishEuro1	4/4	4	112	○		:
DrPc	World	6803	MC1_TurkishEuro1	4/4	4	112	○		:
DrPc	World	6804	FA1_TurkishEuro1	4/4	1	112	○		:
DrPc	World	6805	FB1_TurkishEuro1	4/4	1	112	○		:
DrPc	World	6806	FC1_TurkishEuro1	4/4	1	112	○		:
DrPc	World	6807	BA1_TurkishEuro1	4/4	1	112	○		:
DrPc	World	6808	EA1_TurkishEuro1	4/4	3	112	○		:
DrPc	World	6809	MA2_TurkishEuro1	4/4	4	112	○		*Turkish Kit*
DrPc	World	6810	MB2_TurkishEuro1	4/4	4	112	○		:
DrPc	World	6811	MC2_TurkishEuro1	4/4	4	112	○		:
DrPc	World	6812	FA2_TurkishEuro1	4/4	1	112	○		:
DrPc	World	6813	FB2_TurkishEuro1	4/4	1	112	○		:
DrPc	World	6814	FC2_TurkishEuro1	4/4	1	112	○		:
DrPc	World	6815	BA2_TurkishEuro1	4/4	1	112	○		:
DrPc	World	6816	EA2_TurkishEuro1	4/4	3	112	○		:
DrPc	World	6817	MA1_TurkishEuro2	4/4	4	120	○		*Nu Hip Hop Kit 1*
DrPc	World	6818	MB1_TurkishEuro2	4/4	4	120	○		:
DrPc	World	6819	MC1_TurkishEuro2	4/4	4	120	○		:
DrPc	World	6820	FA1_TurkishEuro2	4/4	1	120	○		:
DrPc	World	6821	FB1_TurkishEuro2	4/4	1	120	○		:
DrPc	World	6822	FC1_TurkishEuro2	4/4	1	120	○		:
DrPc	World	6823	BA1_TurkishEuro2	4/4	1	120	○		:
DrPc	World	6824	EA1_TurkishEuro2	4/4	3	120	○		:
DrPc	World	6825	MA2_TurkishEuro2	4/4	4	120	○		*Turkish Kit*
DrPc	World	6826	MB2_TurkishEuro2	4/4	4	120	○		:
DrPc	World	6827	MC2_TurkishEuro2	4/4	4	120	○		:
DrPc	World	6828	FA2_TurkishEuro2	4/4	1	120	○		:
DrPc	World	6829	FB2_TurkishEuro2	4/4	1	120	○		:
DrPc	World	6830	FC2_TurkishEuro2	4/4	1	120	○		:
DrPc	World	6831	BA2_TurkishEuro2	4/4	1	120	○		:
DrPc	World	6832	EA2_TurkishEuro2	4/4	3	120	○		:
DrPc	World	6833	MA1_Saeidy	4/4	2	120	○		*Hip Hop Kit 3*
DrPc	World	6834	MB1_Saeidy	4/4	2	120	○		:
DrPc	World	6835	MC1_Saeidy	4/4	4	120	○		:
DrPc	World	6836	FA1_Saeidy	4/4	1	120	○		:
DrPc	World	6837	FB1_Saeidy	4/4	1	120	○		:
DrPc	World	6838	FC1_Saeidy	4/4	1	120	○		:
DrPc	World	6839	BA1_Saeidy	4/4	1	120	○		:
DrPc	World	6840	EA1_Saeidy	4/4	4	120	○		:
DrPc	World	6841	MA2_Saeidy	4/4	2	120	○		*Turkish Kit*
DrPc	World	6842	MB2_Saeidy	4/4	2	120	○		:
DrPc	World	6843	MC2_Saeidy	4/4	4	120	○		:
DrPc	World	6844	FA2_Saeidy	4/4	1	120	○		:
DrPc	World	6845	FB2_Saeidy	4/4	1	120	○		:
DrPc	World	6846	FC2_Saeidy	4/4	1	120	○		:
DrPc	World	6847	BA2_Saeidy	4/4	1	120	○		:
DrPc	World	6848	EA2_Saeidy	4/4	4	120	○		:
DrPc	World	6849	MA_PercussionMaster	4/4	2	110	○		PercussionMaster Kit*
DrPc	World	6850	MB_PercussionMaster	4/4	2	110	○		:
DrPc	World	6851	MC_PercussionMaster	4/4	2	110	○		:
DrPc	World	6852	MD_PercussionMaster	4/4	2	110	○		:
DrPc	World	6853	ME_PercussionMaster	4/4	4	110	○		:
DrPc	World	6854	MA_8Z Djembe	4/4	2	100	○		*8Z Djembe*
DrPc	World	6855	MB_8Z Djembe	4/4	2	100	○		:
DrPc	World	6856	MC_8Z Djembe	4/4	2	100	○		:
DrPc	World	6857	MD_8Z Djembe	4/4	2	100	○		:
DrPc	World	6858	BA_8Z Djembe	4/4	2	100	○		:
DrPc	World	6859	BB_8Z Djembe	4/4	2	100	○		:
DrPc	World	6860	MA_8Z Cajon	4/4	2	110	○		*8Z Cajon*
DrPc	World	6861	MB_8Z Cajon	4/4	2	110	○		:
DrPc	World	6862	MC_8Z Cajon	4/4	2	110	○		:
DrPc	World	6863	MD_8Z Cajon	4/4	2	110	○		:
DrPc	World	6864	EA_8Z Cajon	4/4	3	110	○		:
DrPc	World	6865	MA_Japan	4/4	4	103	○		*Japan Kit*
DrPc	World	6866	MB_Japan	4/4	4	103	○		:
DrPc	World	6867	MC_Japan	4/4	4	103	○		:
DrPc	World	6868	MD_Japan	4/4	2	103	○		:
DrPc	World	6869	EA_Japan	4/4	4	103	○		:
DrPc	Genrl	6870	MA_Orchestra	4/4	4	102	○		*Orchestra Kit*
DrPc	Genrl	6871	MC_Orchestra	4/4	8	102	○		:
DrPc	Genrl	6872	MD_Orchestra	4/4	4	102	○		:
DrPc	Genrl	6873	FA_Orchestra	4/4	1	102	○		:
DrPc	Genrl	6874	MA_Nu Orchestra	4/4	4	120	○		*Nu Orchestra Kit*
DrPc	Genrl	6875	MB_Nu Orchestra	4/4	4	120	○		:
DrPc	Genrl	6876	MC_Nu Orchestra	4/4	4	120	○		:
DrPc	Genrl	6877	MD_Nu Orchestra	4/4	2	120	○		:
DrPc	Genrl	6878	ME_Nu Orchestra	4/4	1	120	○		:
DrPc	Genrl	6879	MF_Nu Orchestra	4/4	4	120	○		:
DrPc	Genrl	6880	8Beat Slice1	4/4	1	135	○		*Power Standard Kit 1*
DrPc	Genrl	6881	8Beat Slice2	4/4	1	135	○		:
DrPc	Genrl	6882	8Beat Slice3	4/4	1	135	○		:
DrPc	Genrl	6883	16BeatSlice1	4/4	1	135	○		:

Main Category	Sub Category	ARP No.	ARP Name	Time Signature	Length	Original Tempo	Accent	Random SFX	Voice Type
DrPc	Genrl	6884	16BeatSlice2	4/4	1	135	○		*Power Standard Kit 1*
DrPc	Genrl	6885	1Bar Slice	4/4	1	135	○		:
DrPc	Genrl	6886	1BarRndSlice	4/4	1	135	○		:
DrPc	Genrl	6887	Roll 1	4/4	1	120	○		:
DrPc	Genrl	6888	Roll 2	4/4	1	120	○		:
DrPc	Genrl	6889	Roll 3	4/4	1	120	○		:
DrPc	Genrl	6890	Roll 4	4/4	1	120	○		:
DrPc	Genrl	6891	Linear	4/4	1	120	○		:
Seq	Rock	6892	MA_AlternaRock2_ES	4/4	4	100			Syn Comp/Lead
Seq	Rock	6893	MB_AlternaRock2_ES	4/4	4	100			:
Seq	Rock	6894	MC_AlternaRock2_ES	4/4	4	100			:
Seq	Rock	6895	FA_AlternaRock2_ES	4/4	1	100			:
Seq	Rock	6896	FB_AlternaRock2_ES	4/4	1	100			:
Seq	Rock	6897	FC_AlternaRock2_ES	4/4	1	100			:
Seq	Rock	6898	BA_AlternaRock2_ES	4/4	2	100			:
Seq	PopRk	6899	MA1_Electro Pop	4/4	1	94			:
Seq	PopRk	6900	MB1_Electro Pop	4/4	1	94			:
Seq	PopRk	6901	MC1_Electro Pop	4/4	1	94			:
Seq	PopRk	6902	MD1_Electro Pop	4/4	1	94			:
Seq	PopRk	6903	MA2_Electro Pop	4/4	1	94			:
Seq	PopRk	6904	MA2_Electro Pop AF1	4/4	1	94			:
Seq	PopRk	6905	MA2_Electro Pop AF2	4/4	4	94			:
Seq	PopRk	6906	MB2_Electro Pop	4/4	1	94			:
Seq	PopRk	6907	MA3_Electro Pop	4/4	1	94			:
Seq	PopRk	6908	MB3_Electro Pop	4/4	4	94			:
Seq	PopRk	6909	MC3_Electro Pop	4/4	1	94			:
Seq	PopRk	6910	MD3_Electro Pop	4/4	1	94			:
Seq	PopRk	6911	ME3_Electro Pop	4/4	1	94			:
Seq	PopRk	6912	MA_Voxdance	4/4	1	90			:
Seq	PopRk	6913	MA_Voxdance AF2	4/4	1	90			:
Seq	PopRk	6914	MB_Voxdance	4/4	1	90			:
Seq	PopRk	6915	MB_Voxdance AF1	4/4	1	90			:
Seq	PopRk	6916	MA_Jumping	4/4	4	90			:
Seq	PopRk	6917	MB_Jumping	4/4	4	90			:
Seq	PopRk	6918	MB_Jumping AF1	4/4	1	90			:
Seq	PopRk	6919	MB_Jumping AF2	4/4	4	90			:
Seq	PopRk	6920	MA_80'sSynthRock_XS	4/4	4	96			:
Seq	PopRk	6921	MB_80'sSynthRock_XS	4/4	4	96			:
Seq	PopRk	6922	MC_80'sSynthRock_XS	4/4	8	96			:
Seq	PopRk	6923	FA_80'sSynthRock_XS	4/4	1	96			:
Seq	PopRk	6924	FB_80'sSynthRock_XS	4/4	1	96			:
Seq	PopRk	6925	FC_80'sSynthRock_XS	4/4	1	96			:
Seq	PopRk	6926	BA_80'sSynthRock_XS	4/4	1	96			:
Seq	PopRk	6927	EA_80'sSynthRock_XS	4/4	3	96			:
Seq	HipHp	6928	MA_2BZ4U	4/4	2	75			:
Seq	HipHp	6929	MB_2BZ4U	4/4	2	75			:
Seq	HipHp	6930	MC_2BZ4U	4/4	2	75			:
Seq	HipHp	6931	MD_2BZ4U	4/4	2	75			:
Seq	HipHp	6932	MA_PepRally	4/4	4	75			:
Seq	HipHp	6933	MB_PepRally	4/4	4	75			:
Seq	HipHp	6934	MC_Hip Hop 3_ES	4/4	2	104			:
Seq	HipHp	6935	MD_Hip Hop 3	4/4	2	104			:
Seq	HipHp	6936	FB_Hip Hop 3	4/4	1	104			:
Seq	HipHp	6937	MA_Hip Rock 2_XS	4/4	4	132			:
Seq	HipHp	6938	MB_Hip Rock 2_XS	4/4	4	132			:
Seq	HipHp	6939	MC_Hip Rock 2_XS	4/4	4	132			:
Seq	HipHp	6940	FA_Hip Rock 2_XS	4/4	1	132			:
Seq	HipHp	6941	FB_Hip Rock 2_XS	4/4	1	132			:
Seq	HipHp	6942	FC_Hip Rock 2_XS	4/4	1	132			:
Seq	HipHp	6943	MA_Dancehall_XS	4/4	4	103			:
Seq	HipHp	6944	MB_Dancehall_XS	4/4	4	103			:
Seq	HipHp	6945	MD_Dancehall_XS	4/4	4	103			:
Seq	HipHp	6946	FA_Dancehall_XS	4/4	1	103			:
Seq	HipHp	6947	FB_Dancehall_XS	4/4	1	103			:
Seq	HipHp	6948	FD_Dancehall_XS	4/4	1	103			:
Seq	HipHp	6949	BA_Dancehall_XS	4/4	1	103			:
Seq	HipHp	6950	EA_Dancehall_XS	4/4	3	103			:
Seq	HipHp	6951	MA_Funky Chop	4/4	1	120			:
Seq	R&B-M	6952	MB_R&B Disco_ES	4/4	2	110			:
Seq	R&B-M	6953	MC_R&B Disco_ES	4/4	2	110			:
Seq	R&B-M	6954	MA_Chart R&B_XS	4/4	4	130			:
Seq	R&B-M	6955	MB_Chart R&B_XS	4/4	4	130			:
Seq	R&B-M	6956	MC_Chart R&B_XS	4/4	4	130			:
Seq	R&B-M	6957	FA_Chart R&B_XS	4/4	1	130			:
Seq	R&B-M	6958	FB_Chart R&B_XS	4/4	1	130			:
Seq	R&B-M	6959	FC_Chart R&B_XS	4/4	1	130			:
Seq	R&B-M	6960	BA_Chart R&B_XS	4/4	1	130			:
Seq	R&B-M	6961	EA_Chart R&B_XS	4/4	5	130			:
Seq	R&B-M	6962	EB_Chart R&B_XS	4/4	10	130			:
Seq	R&B-M								

Arpeggio Type List

Main Category	Sub Category	ARP No.	ARP Name	Time Signature	Length	Original Tempo	Accent	Random SFX	Voice Type
Seq	Tekno	6967	MB1_Trance 2_XS	4/4	8	135			Syn Comp/Lead
Seq	Tekno	6968	MC1_Trance 2_XS	4/4	8	135			:
Seq	Tekno	6969	FA1_Trance 2_XS	4/4	1	135			:
Seq	Tekno	6970	FB1_Trance 2_XS	4/4	8	135			:
Seq	Tekno	6971	FC1_Trance 2_XS	4/4	1	135			:
Seq	Tekno	6972	BA1_Trance 2_XS	4/4	1	135			:
Seq	Tekno	6973	MA2_Trance 2_XS	4/4	8	135			:
Seq	Tekno	6974	MB2_Trance 2_XS	4/4	8	135			:
Seq	Tekno	6975	MC2_Trance 2_XS	4/4	8	135			:
Seq	Tekno	6976	FA2_Trance 2_XS	4/4	1	135			:
Seq	Tekno	6977	FB2_Trance 2_XS	4/4	8	135			:
Seq	Tekno	6978	FC2_Trance 2_XS	4/4	1	135			:
Seq	Tekno	6979	BA2_Trance 2_XS	4/4	1	135			:
Seq	Tekno	6980	MA1_Trance 2_ES	4/4	8	135			:
Seq	Tekno	6981	MB1_Trance 2_ES	4/4	8	135			:
Seq	Tekno	6982	MC1_Trance 2_ES	4/4	8	135			:
Seq	Tekno	6983	FA1_Trance 2_ES	4/4	1	135			:
Seq	Tekno	6984	FB1_Trance 2_ES	4/4	8	135			:
Seq	Tekno	6985	BA1_Trance 2_ES	4/4	1	135			:
Seq	Tekno	6986	MA2_Trance 2_ES	4/4	8	135			:
Seq	Tekno	6987	MB2_Trance 2_ES	4/4	8	135			:
Seq	Tekno	6988	MC2_Trance 2_ES	4/4	8	135			:
Seq	Tekno	6989	FA2_Trance 2_ES	4/4	1	135			:
Seq	Tekno	6990	FB2_Trance 2_ES	4/4	8	135			:
Seq	Tekno	6991	FC2_Trance 2_ES	4/4	1	135			:
Seq	Tekno	6992	BA2_Trance 2_ES	4/4	1	135			:
Seq	Tekno	6993	MA_Trance 3_XS	4/4	2	140			:
Seq	Tekno	6994	MB_Trance 3_XS	4/4	2	140			:
Seq	Tekno	6995	MC_Trance 3_XS	4/4	3	140			:
Seq	Tekno	6996	FA_Trance 3_XS	4/4	2	140			:
Seq	Tekno	6997	FB_Trance 3_XS	4/4	2	140			:
Seq	Tekno	6998	FC_Trance 3_XS	4/4	4	140			:
Seq	Tekno	6999	BA_Trance 3_XS	4/4	1	140			:
Seq	Tekno	7000	MA_Trance 3_ES	4/4	2	140			:
Seq	Tekno	7001	MB_Trance 3_ES	4/4	2	140			:
Seq	Tekno	7002	MC_Trance 3_ES	4/4	3	140			:
Seq	Tekno	7003	FA_Trance 3_ES	4/4	2	140			:
Seq	Tekno	7004	FB_Trance 3_ES	4/4	2	140			:
Seq	Tekno	7005	FC_Trance 3_ES	4/4	4	140			:
Seq	Tekno	7006	BA_Trance 3_ES	4/4	1	140			:
Seq	Tekno	7007	MB1_Trance 5	4/4	1	140			:
Seq	Tekno	7008	MA2_Trance 5	4/4	4	140			:
Seq	Tekno	7009	MD2_Trance 5	4/4	4	140			:
Seq	Tekno	7010	IA3_Trance 5	4/4	1	140			:
Seq	Tekno	7011	FC3_Trance 5	4/4	1	140			:
Seq	Tekno	7012	MB4_Trance 5	4/4	4	140			:
Seq	Tekno	7013	FA4_Trance 5	4/4	4	140			:
Seq	Tekno	7014	FA5_Trance 5	4/4	4	140			:
Seq	Tekno	7015	FC5_Trance 5	4/4	1	140			:
Seq	Tekno	7016	MC6_Trance 5	4/4	4	140			:
Seq	Tekno	7017	MA_PsycheSeq1_ES	4/4	4	140			:
Seq	Tekno	7018	MA_PsycheSeq2_ES	4/4	1	140			:
Seq	Tekno	7019	MA_PsycheSeq3_ES	4/4	2	140			:
Seq	Tekno	7020	MA_PsycheSeq4_ES	4/4	4	140			:
Seq	Tekno	7021	MA_PsycheSeq5_ES	4/4	6	140			:
Seq	Tekno	7022	MA_TrancePhras1	4/4	1	130			:
Seq	Tekno	7023	MA_TrancePhras2	4/4	1	130			:
Seq	Tekno	7024	MA_TrancePhras3	4/4	1	130			:
Seq	Tekno	7025	MA_TrancePhras4	4/4	1	130			:
Seq	Tekno	7026	MA_TrancePhras5	4/4	1	130			:
Seq	Tekno	7027	MA_TrancePhras6	4/4	1	130			:
Seq	Tekno	7028	MA_TrancePhras7	4/4	1	130			:
Seq	Tekno	7029	MA_TrancePhras8	4/4	2	145			:
Seq	Tekno	7030	MA_TrancePhras9	4/4	1	145			:
Seq	Tekno	7031	MA_TrancePhrs10	4/4	2	145			:
Seq	Tekno	7032	MA_TrancePhrs11	4/4	2	145			:
Seq	Tekno	7033	MA_TrancePhrs12	4/4	2	145			:
Seq	Tekno	7034	MA_TrancePhrs13	4/4	2	145			:
Seq	Tekno	7035	MA_TrancePhrs14	4/4	1	145			:
Seq	Tekno	7036	MA_TrancePhrs15	4/4	1	145			:
Seq	Tekno	7037	MA_PsychePhras1_ES	4/4	1	143			:
Seq	Tekno	7038	MA_PsychePhras2_ES	4/4	1	143			:
Seq	Tekno	7039	MA_PsychePhras3_ES	4/4	2	143			:
Seq	Tekno	7040	MA_PsychePhras4_ES	4/4	2	143			:
Seq	Tekno	7041	MA_PsychePhras5_ES	4/4	2	143			:
Seq	Tekno	7042	MA_HyperTrance1_ES	4/4	1	143			:
Seq	Tekno	7043	MA_HyperTrance2_ES	4/4	2	143			:
Seq	Tekno	7044	MA_HyperTrance3_ES	4/4	1	143			:
Seq	Tekno	7045	MA_HyperTrance4_ES	4/4	1	143			:
Seq	Tekno	7046	MA_HyperTrance5_ES	4/4	1	143			:
Seq	Tekno	7047	MA1_Trance Vision	4/4	1	134			:
Seq	Tekno	7048	MB1_Trance Vision	4/4	1	134			:
Seq	Tekno	7049	MC1_Trance Vision	4/4	1	134			:

Main Category	Sub Category	ARP No.	ARP Name	Time Signature	Length	Original Tempo	Accent	Random SFX	Voice Type
Seq	Tekno	7050	MD1_Trance Vision	4/4	1	134			Syn Comp/Lead
Seq	Tekno	7051	ME1_Trance Vision	4/4	1	134			:
Seq	Tekno	7052	MA2_Trance Vision	4/4	1	134			:
Seq	Tekno	7053	MA2_TranceVision AF2	4/4	1	134			:
Seq	Tekno	7054	MA2_TmcVision AF1&2	4/4	1	134			:
Seq	Tekno	7055	MB2_Trance Vision	4/4	1	134			:
Seq	Tekno	7056	MB2_TranceVision AF1	4/4	1	134			:
Seq	Tekno	7057	MB2_TranceVision AF2	4/4	4	134			:
Seq	Tekno	7058	MB2_TmcVision AF1&2	4/4	4	134			:
Seq	Tekno	7059	MA1_Dream Trance	4/4	1	140			:
Seq	Tekno	7060	MA1_Dream Trance AF1	4/4	1	140			:
Seq	Tekno	7061	MB1_Dream Trance	4/4	1	140			:
Seq	Tekno	7062	MC1_Dream Trance	4/4	1	140			:
Seq	Tekno	7063	MC1_Dream Trance AF1	4/4	1	140			:
Seq	Tekno	7064	MC1_Dream Trance AF2	4/4	1	140			:
Seq	Tekno	7065	MC1_Dream Trnc AF1&2	4/4	1	140			:
Seq	Tekno	7066	MA1_Electrix	4/4	1	119			:
Seq	Tekno	7067	MA1_Electrix AF1	4/4	1	119			:
Seq	Tekno	7068	MB1_Electrix	4/4	1	119			:
Seq	Tekno	7069	MA2_Electrix	4/4	1	119			:
Seq	Tekno	7070	MB2_Electrix	4/4	1	119			:
Seq	Tekno	7071	MA1_Cool Breakz	4/4	1	116			:
Seq	Tekno	7072	MA1_Cool Breakz AF1	4/4	1	116			:
Seq	Tekno	7073	MA1_Cool Breakz AF2	4/4	1	116			:
Seq	Tekno	7074	MB1_Cool Breakz	4/4	1	116			:
Seq	Tekno	7075	MA2_Cool Breakz	4/4	1	116			:
Seq	Tekno	7076	MA1_Synthlines	4/4	1	124			:
Seq	Tekno	7077	MA1_Synthlines AF1	4/4	1	124			:
Seq	Tekno	7078	MB1_Synthlines	4/4	1	124			:
Seq	Tekno	7079	MB1_Synthlines AF1	4/4	1	124			:
Seq	Tekno	7080	MB1_Synthlines AF2	4/4	1	124			:
Seq	Tekno	7081	MB1_Synthlines AF1&2	4/4	1	124			:
Seq	Tekno	7082	MC1_Synthlines	4/4	1	124			:
Seq	Tekno	7083	MD1_Synthlines	4/4	1	124			:
Seq	Tekno	7084	ME1_Synthlines	4/4	4	124			:
Seq	Tekno	7085	MA2_Synthlines	4/4	1	124			:
Seq	Tekno	7086	MB2_Synthlines	4/4	1	124			:
Seq	Tekno	7087	MC2_Synthlines	4/4	1	124			:
Seq	Tekno	7088	MD2_Synthlines	4/4	1	124			:
Seq	Tekno	7089	MA3_Synthlines	4/4	1	124			:
Seq	Tekno	7090	MB3_Synthlines	4/4	1	124			:
Seq	Tekno	7091	MC3_Synthlines	4/4	1	124			:
Seq	Tekno	7092	MD3_Synthlines	4/4	1	124			:
Seq	Tekno	7093	MA1_Acid Breaks	4/4	1	98			:
Seq	Tekno	7094	MB1_Acid Breaks	4/4	1	98			:
Seq	Tekno	7095	MC1_Acid Breaks	4/4	1	98			:
Seq	Tekno	7096	MD1_Acid Breaks	4/4	1	98			:
Seq	Tekno	7097	ME1_Acid Breaks	4/4	1	98			:
Seq	Tekno	7098	MF1_Acid Breaks	4/4	1	98			:
Seq	Tekno	7099	MG1_Acid Breaks	4/4	1	98			:
Seq	Tekno	7100	MH1_Acid Breaks	4/4	1	98			:
Seq	Tekno	7101	MA2_Acid Breaks	4/4	1	98			:
Seq	Tekno	7102	MB2_Acid Breaks	4/4	1	98			:
Seq	Tekno	7103	MC2_Acid Breaks	4/4	4	98			:
Seq	Tekno	7104	MD2_Acid Breaks	4/4	1	98			:
Seq	Tekno	7105	ME2_Acid Breaks	4/4	1	98			:
Seq	Tekno	7106	MF2_Acid Breaks	4/4	4	98			:
Seq	Tekno	7107	MF2_AcidBreaks AF1&2	4/4	4	98			:
Seq	Tekno	7108	MA_T-Line Seq_ES	4/4	1	140			:
Seq	Tekno	7109	MA_TeknoPhrs1 /1_XS	4/4	2	130			:
Seq	Tekno	7110	MA_TeknoPhrs1 /2_XS	4/4	1	130			:
Seq	Tekno	7111	MA_TeknoPhrs1 /3_XS	4/4	1	130			:
Seq	Tekno	7112	MA_TeknoPhrs1 /4_XS	4/4	1	130			:
Seq	Tekno	7113	MA_TeknoPhrs1 /5_XS	4/4	1	110			:
Seq	Tekno	7114	MA_TeknoPhrs1 /6_XS	4/4	1	100			:
Seq	Tekno	7115	MA_TeknoPhras2 /1	4/4	2	120			:
Seq	Tekno	7116	MA_TeknoPhras2 /2	4/4	2	120			:
Seq	Tekno	7117	MA_TeknoPhras2 /3	4/4	2	120			:
Seq	Tekno	7118	MA_TeknoAttack1_ES	4/4	2	143			:
Seq	Tekno	7119	MA_TeknoAttack2_ES	4/4	1	143			:
Seq	Tekno	7120	MA_TeknoAttack3_ES	4/4	1	143			:
Seq	Tekno	7121	MA_TeknoAttack4_ES	4/4	1	143			:
Seq	Tekno	7122	MA_TeknoAttack5_ES	4/4	1	143			:
Seq	Tekno	7123	MA_Acid A1	4/4	2	127			:
Seq	Tekno	7124	MA_Acid A2	4/4	2	127			:
Seq	Tekno	7125	MA_Acid A2 AF1	4/4	2	90			:
Seq	Tekno	7126	MA_Acid A3	4/4	2	127			:
Seq	Tekno	7127	MA_Acid A3 AF1	4/4	2	90			:
Seq	Tekno	7128	MA_Acid A4	4/4	2	127			:
Seq	Tekno	7129	MA_Acid A5	4/4	2	127			:
Seq	Tekno	7130	MA_Acid A6	4/4	2	127			:
Seq	Tekno	7131	MA_Acid A6 AF1	4/4	2	127			:
Seq	Tekno	7132	MA_Acid A6 AF2	4/4	2	127			:

Arpeggio Type List

Main Category	Sub Category	ARP No.	ARP Name	Time Signature	Length	Original Tempo	Accent	Random SFX	Voice Type
Seq	Tekno	7133	MA_Acid B1	4/4	2	127			Syn Comp/Lead
Seq	Tekno	7134	MA_Acid B2	4/4	2	127			:
Seq	Tekno	7135	MA_Acid B3	4/4	2	127			:
Seq	Tekno	7136	MA_Acid B4	4/4	2	127			:
Seq	Tekno	7137	MA_Acid B5	4/4	2	127			:
Seq	Tekno	7138	MA_Acid B6	4/4	2	127			:
Seq	Tekno	7139	MA_Acid C1	4/4	2	127			:
Seq	Tekno	7140	MA_Acid C2	4/4	2	127			:
Seq	Tekno	7141	MA_Acid C3	4/4	2	127			:
Seq	Tekno	7142	MA_Acid C4	4/4	2	127			:
Seq	Tekno	7143	MA_Acid C5	4/4	2	127			:
Seq	Tekno	7144	MA_Acid C6	4/4	2	127			:
Seq	Tekno	7145	MA_Electro1	4/4	1	130			:
Seq	Tekno	7146	MA_Electro2	4/4	1	130			:
Seq	Tekno	7147	MA_Electro3	4/4	1	130			:
Seq	Tekno	7148	MA_Electro3 AF2	4/4	1	123			:
Seq	Tekno	7149	MA_Electro4	4/4	1	130			:
Seq	Tekno	7150	MA_Electro5	4/4	1	130			:
Seq	Tekno	7151	MA_Electro6	4/4	1	130			:
Seq	Tekno	7152	MA_Electro7	4/4	1	130			:
Seq	Tekno	7153	MA_Electro8	4/4	1	130			:
Seq	Tekno	7154	MA_Electro9	4/4	1	130			:
Seq	Tekno	7155	MA_Electro10	4/4	1	130			:
Seq	Tekno	7156	MA_Electro10 AF2	4/4	1	123			:
Seq	Tekno	7157	MA_Electro11	4/4	1	130			:
Seq	Tekno	7158	MA_Electro12	4/4	1	130			:
Seq	Tekno	7159	MA_Electro13	4/4	1	130			:
Seq	Tekno	7160	MA_Electro14	4/4	1	130			:
Seq	Tekno	7161	MA_CompBass1	4/4	1	130			:
Seq	Tekno	7162	MA_CompBass2	4/4	1	130			:
Seq	Tekno	7163	MA_CompBass2 AF2	4/4	8	134			:
Seq	Tekno	7164	MA_CompBass3	4/4	1	130			:
Seq	Tekno	7165	MA_CompBass4	4/4	1	130			:
Seq	Tekno	7166	MA_Digi Seq1_ES	4/4	2	106			:
Seq	Tekno	7167	MA_Digi Seq2_ES	4/4	2	106			:
Seq	Tekno	7168	MA_Digi Seq3_ES	4/4	2	106			:
Seq	Tekno	7169	MA_Digi Seq4_ES	4/4	1	106			:
Seq	Tekno	7170	MA_Digi Seq5_ES	4/4	1	106			:
Seq	Tekno	7171	MA_DigySeq1_ES	4/4	4	135			:
Seq	Tekno	7172	MA_DigySeq2_ES	4/4	2	135			:
Seq	Tekno	7173	MA_DigySeq3_ES	4/4	2	135			:
Seq	Tekno	7174	MA_DigySeq4_ES	4/4	2	135			:
Seq	Tekno	7175	MA_DigySeq5_ES	4/4	1	135			:
Seq	Tekno	7176	MA_Seq S&H1	4/4	4	120			:
Seq	Tekno	7177	MA_Seq S&H2	4/4	4	120			:
Seq	Tekno	7178	MA_Poly Arp1	4/4	1	120			:
Seq	Tekno	7179	MA_Poly Arp2	4/4	1	120			:
Seq	Tekno	7180	MA_Boiler1	4/4	1	120			:
Seq	Tekno	7181	MA_Boiler2	4/4	1	120			:
Seq	Tekno	7182	MA_Boiler3	4/4	1	120			:
Seq	Tekno	7183	MA_Boiler4	4/4	1	110			:
Seq	Tekno	7184	MA_Bees1	4/4	1	118			:
Seq	Tekno	7185	MA_Bees2	4/4	1	118			:
Seq	Tekno	7186	MA_Bees3	4/4	1	118			:
Seq	Tekno	7187	MA_Syncopa1	4/4	2	120			:
Seq	Tekno	7188	MA_Tek Echo1	4/4	2	120			:
Seq	Tekno	7189	MA_Super Arp	4/4	2	120			:
Seq	Tekno	7190	MA_Space Arp	4/4	2	120			:
Seq	Tekno	7191	MA_Step Line	4/4	1	120			:
Seq	Tekno	7192	MA_Acid Line	4/4	1	120			:
Seq	Tekno	7193	MA_Ana Seq	4/4	1	120			:
Seq	Tekno	7194	MA_Ascorbic	4/4	1	150			:
Seq	Tekno	7195	MA_Beeperz	4/4	2	104			:
Seq	Tekno	7196	MA_Doves	4/4	1	150			:
Seq	Tekno	7197	MA_Europluk	4/4	1	105			:
Seq	Tekno	7198	MA_Hardcore	4/4	3	150			:
Seq	Tekno	7199	MA_Harmo	4/4	1	150			:
Seq	Tekno	7200	MA_Lamb	4/4	1	125			:
Seq	Tekno	7201	MA_Ocean	4/4	1	120			:
Seq	Tekno	7202	MA_Orbit	4/4	1	140			:
Seq	Tekno	7203	MA_Pitz	4/4	1	105			:
Seq	Tekno	7204	MA_Planet	4/4	1	120			:
Seq	Tekno	7205	MA_Poly Dance	4/4	1	120			:
Seq	Tekno	7206	MA_Popcom	4/4	1	120			:
Seq	Tekno	7207	MA_Puls Line	4/4	2	120			:
Seq	Tekno	7208	MA_Simple	4/4	2	150			:
Seq	Tekno	7209	MA_Split Arp	4/4	1	120			:
Seq	Tekno	7210	MA_Step Seq	4/4	1	120			:
Seq	Tekno	7211	MA_SyncopaEcho	4/4	2	120			:
Seq	Tekno	7212	MA_Tek Bubble	4/4	1	128			:
Seq	Tekno	7213	MA_Thips	4/4	1	140			:
Seq	Tekno	7214	MA_Waggle	4/4	1	100			:
Seq	Tekno	7215	MA_TranceRtm1	4/4	4	135			:

Main Category	Sub Category	ARP No.	ARP Name	Time Signature	Length	Original Tempo	Accent	Random SFX	Voice Type
Seq	Tekno	7216	MA_TranceRtm2	4/4	4	140			Syn Comp/Lead
Seq	Tekno	7217	MA_TranceRtm3	4/4	4	140			:
Seq	Tekno	7218	MA_Trance Slab	4/4	2	140			:
Seq	Tekno	7219	MA_T-Line Chd	4/4	4	140			:
Seq	Tekno	7220	MA_Syncopa2	4/4	2	120			:
Seq	Tekno	7221	MA_Tek Echo2	4/4	2	120			:
Seq	Tekno	7222	MA_Fugue	4/4	2	120			:
Seq	Tekno	7223	MA_Rave Swp	4/4	4	135			:
Seq	Tekno	7224	MA_Rosync	4/4	1	120			:
Seq	Tekno	7225	MA_Synclavk	4/4	2	140			:
Seq	Tekno	7226	MA_HiFive	4/4	1	118			:
Seq	House	7227	MC1_Dream Dance	4/4	1	136			:
Seq	House	7228	FC1_Dream Dance	4/4	1	136			:
Seq	House	7229	MA2_Dream Dance	4/4	1	136			:
Seq	House	7230	MD2_Dream Dance	4/4	1	136			:
Seq	House	7231	FC2_Dream Dance	4/4	1	136			:
Seq	House	7232	MB3_Dream Dance	4/4	1	136			:
Seq	House	7233	MD1_Ibiza	4/4	2	135			:
Seq	House	7234	IA1_Ibiza	4/4	8	135			:
Seq	House	7235	MB2_Ibiza_ES	4/4	2	135			:
Seq	House	7236	MD2_Ibiza_ES	4/4	2	135			:
Seq	House	7237	MB3_Ibiza_ES	4/4	2	135			:
Seq	House	7238	MC3_Ibiza_ES	4/4	2	135			:
Seq	House	7239	MA_Retro Pop	4/4	1	126			:
Seq	House	7240	MD_Retro Pop	4/4	2	126			:
Seq	House	7241	FC_Retro Pop	4/4	1	100			:
Seq	House	7242	IA_Dream Dance	4/4	2	136			:
Seq	House	7243	MA_Ibiza	4/4	1	135			:
Seq	House	7244	MB_Ibiza	4/4	2	135			:
Seq	House	7245	MC_Ibiza	4/4	2	135			:
Seq	House	7246	MD_Ibiza	4/4	2	135			:
Seq	House	7247	IA_Ibiza	4/4	8	135			:
Seq	House	7248	FA_Ibiza	4/4	1	135			:
Seq	House	7249	FB_Ibiza	4/4	1	135			:
Seq	House	7250	MB_Garage 2	4/4	2	127			:
Seq	House	7251	MC_Garage 2	4/4	2	127			:
Seq	House	7252	MD_Garage 2	4/4	2	127			:
Seq	House	7253	IA_Garage 2	4/4	2	127			:
Seq	House	7254	FA_Garage 2	4/4	2	127			:
Seq	D&B	7255	MA_Big Beat 1_ES	4/4	4	115			:
Seq	D&B	7256	MB_Big Beat 1_ES	4/4	4	115			:
Seq	D&B	7257	MC_Big Beat 1_ES	4/4	4	115			:
Seq	D&B	7258	FA_Big Beat 1_ES	4/4	1	115			:
Seq	D&B	7259	FB_Big Beat 1_ES	4/4	1	115			:
Seq	D&B	7260	FC_Big Beat 1_ES	4/4	1	115			:
Seq	D&B	7261	BA_Big Beat 1_ES	4/4	1	115			:
Seq	D&B	7262	MA_Big Step1_ES	4/4	2	116			:
Seq	D&B	7263	MA_Big Step2_ES	4/4	1	116			:
Seq	D&B	7264	MA_Big Step3_ES	4/4	2	116			:
Seq	D&B	7265	MA_Big Step4_ES	4/4	1	116			:
Seq	D&B	7266	MA_Big Step5_ES	4/4	1	116			:
Seq	D&B	7267	MA_Breakbeats 1_ES	4/4	4	115			:
Seq	D&B	7268	MB_Breakbeats 1_ES	4/4	4	115			:
Seq	D&B	7269	MC_Breakbeats 1_ES	4/4	2	115			:
Seq	D&B	7270	FA_Breakbeats 1_ES	4/4	1	115			:
Seq	D&B	7271	FB_Breakbeats 1_ES	4/4	1	115			:
Seq	D&B	7272	FC_Breakbeats 1_ES	4/4	1	115			:
Seq	D&B	7273	BA_Breakbeats 1_ES	4/4	1	115			:
Seq	D&B	7274	MA_Breakbeats 2_ES	4/4	4	88			:
Seq	D&B	7275	MB_Breakbeats 2_ES	4/4	4	88			:
Seq	D&B	7276	MC_Breakbeats 2_ES	4/4	4	88			:
Seq	D&B	7277	FA_Breakbeats 2_ES	4/4	1	88			:
Seq	D&B	7278	FB_Breakbeats 2_ES	4/4	1	88			:
Seq	D&B	7279	FC_Breakbeats 2_ES	4/4	1	88			:
Seq	D&B	7280	BA_Breakbeats 2_ES	4/4	1	88			:
Seq	Chill	7281	MA1_Ambient 1_ES	4/4	4	102			:
Seq	Chill	7282	MB1_Ambient 1_ES	4/4	4	102			:
Seq	Chill	7283	MC1_Ambient 1_ES	4/4	4	102			:
Seq	Chill	7284	FA1_Ambient 1_ES	4/4	1	102			:
Seq	Chill	7285	FB1_Ambient 1_ES	4/4	1	102			:
Seq	Chill	7286	FC1_Ambient 1_ES	4/4	1	102			:
Seq	Chill	7287	BA1_Ambient 1_ES	4/4	1	102			:
Seq	Chill	7288	MB2_Ambient 1_ES	4/4	4	102			:
Seq	Chill	7289	MC2_Ambient 1_ES	4/4	4	102			:
Seq	Chill	7290	FB2_Ambient 1_ES	4/4	1	102			:
Seq	Chill	7291	FC2_Ambient 1_ES	4/4	1	102			:
Seq	Chill	7292	BA2_Ambient 1_ES	4/4	1	102			:
Seq	Chill	7293	MA1_Ambient 2_XS	4/4	4	111			:
Seq	Chill	7294	MB1_Ambient 2_XS	4/4	2	111			:
Seq	Chill	7295	MC1_Ambient 2_XS	4/4	4	111			:
Seq	Chill	7296	FB1_Ambient 2_XS	4/4	8	111			:
Seq	Chill	7297	FC1_Ambient 2_XS	4/4	1	111			:
Seq	Chill	7298	MA2_Ambient 2_XS	4/4	4	111			:

Arpeggio Type List

Main Category	Sub Category	ARP No.	ARP Name	Time Signature	Length	Original Tempo	Accent	Random SFX	Voice Type
Seq	Chill	7299	MC2_Ambient 2_XS	4/4	4	111			Syn Comp/Lead
Seq	Chill	7300	FA2_Ambient 2_XS	4/4	1	111			:
Seq	Chill	7301	FB2_Ambient 2_XS	4/4	8	111			:
Seq	Chill	7302	FC2_Ambient 2_XS	4/4	1	111			:
Seq	Chill	7303	BA2_Ambient 2_XS	4/4	2	111			:
Seq	Chill	7304	MA1_Ambient 2_ES	4/4	4	111			:
Seq	Chill	7305	MB1_Ambient 2_ES	4/4	2	111			:
Seq	Chill	7306	MC1_Ambient 2_ES	4/4	4	111			:
Seq	Chill	7307	FB1_Ambient 2_ES	4/4	8	111			:
Seq	Chill	7308	FC1_Ambient 2_ES	4/4	1	111			:
Seq	Chill	7309	MA2_Ambient 2_ES	4/4	4	111			:
Seq	Chill	7310	MC2_Ambient 2_ES	4/4	4	111			:
Seq	Chill	7311	FA2_Ambient 2_ES	4/4	1	111			:
Seq	Chill	7312	FB2_Ambient 2_ES	4/4	8	111			:
Seq	Chill	7313	FC2_Ambient 2_ES	4/4	1	111			:
Seq	Chill	7314	BA2_Ambient 2_ES	4/4	2	111			:
Seq	Chill	7315	MA1_Ambient 3	4/4	4	75			:
Seq	Chill	7316	MA2_Ambient 3	4/4	4	75			:
Seq	Chill	7317	MA3_Ambient 3	4/4	2	75			:
Seq	Chill	7318	MA_Ambient 4	4/4	1	80			:
Seq	Chill	7319	MA_Ambient 4 AF2	4/4	1	80			:
Seq	Chill	7320	MC_Chill Out	4/4	4	79			:
Seq	Chill	7321	MD_Chill Out	4/4	2	79			:
Seq	Chill	7322	FB_Chill Out	4/4	1	79			:
Seq	Chill	7323	MA_Synth Pop	4/4	1	90			:
Seq	Chill	7324	MB_Synth Pop	4/4	1	90			:
Seq	Chill	7325	MD_Synth Pop	4/4	1	90			:
Seq	Chill	7326	IA_Synth Pop	4/4	1	90			:
Seq	Chill	7327	FC_Synth Pop	4/4	1	90			:
Seq	Chill	7328	MA_Chill Out	4/4	2	79			:
Seq	Chill	7329	MB_Chill Out	4/4	2	79			:
Seq	Chill	7330	FA_Chill Out	4/4	1	79			:
Seq	Chill	7331	MA_ChillinChord1	4/4	1	90			:
Seq	Chill	7332	MA_ChillinChord1 AF2	4/4	1	90			:
Seq	Chill	7333	MA_ChillinChord1AF1&2	4/4	1	90			:
Seq	Chill	7334	MA_ChillinChord2	4/4	1	90			:
Seq	Chill	7335	MA_ChillinChord2 AF1	4/4	1	90			:
Seq	Chill	7336	MA_ChillinChord3	4/4	1	90			:
Seq	Chill	7337	MA_ChillinChord4	4/4	1	90			:
Seq	Chill	7338	MA_ChillinChord5	4/4	1	90			:
Seq	Chill	7339	MA_ChillinChord6	4/4	1	90			:
Seq	Chill	7340	MA_ChillinChord6 AF1	4/4	1	90			:
Seq	Chill	7341	MA1_Eighties	4/4	1	120			:
Seq	Chill	7342	MB1_Eighties	4/4	1	120			:
Seq	Chill	7343	MC1_Eighties	4/4	1	120			:
Seq	Chill	7344	MD1_Eighties	4/4	1	120			:
Seq	Chill	7345	MA2_Eighties	4/4	1	120			:
Seq	Chill	7346	MA2_Eighties AF1	4/4	1	120			:
Seq	Chill	7347	MA2_Eighties AF2	4/4	1	120			:
Seq	Chill	7348	MB2_Eighties	4/4	1	120			:
Seq	Chill	7349	MB2_Eighties AF1	4/4	1	120			:
Seq	Chill	7350	MA3_Eighties	4/4	1	120			:
Seq	Chill	7351	MA3_Eighties AF1	4/4	1	120			:
Seq	Chill	7352	MB3_Eighties	4/4	1	120			:
Seq	Latin	7353	MA_Latin House	4/4	4	138			:
Seq	Latin	7354	MB_Latin House	4/4	2	138			:
Seq	World	7355	MA_TurkishEuro2_XS	4/4	4	120			:
Seq	World	7356	MB_TurkishEuro2_XS	4/4	4	120			:
Seq	World	7357	MC_TurkishEuro2_XS	4/4	4	120			:
Seq	World	7358	FA_TurkishEuro2_XS	4/4	1	120			:
Seq	World	7359	FB_TurkishEuro2_XS	4/4	1	120			:
Seq	World	7360	FC_TurkishEuro2_XS	4/4	1	120			:
Seq	World	7361	BA_TurkishEuro2_XS	4/4	1	120			:
Seq	World	7362	EA_TurkishEuro2_XS	4/4	3	120			:
Seq	Genrl	7363	MA_SynArp1	4/4	1	130			:
Seq	Genrl	7364	MA_SynArp2	4/4	2	130			:
Seq	Genrl	7365	MA_SynArp3	4/4	1	130			:
Seq	Genrl	7366	MA_SynArp4	4/4	1	130			:
Seq	Genrl	7367	MA_SynArp5	4/4	1	130			:
Seq	Genrl	7368	MA_SynArp6	4/4	1	124			:
Seq	Genrl	7369	MA_SynArp7	4/4	1	120			:
Seq	Genrl	7370	MA_SynArp8	4/4	1	130			:
Seq	Genrl	7371	MA_SynArp9	4/4	1	130			:
Seq	Genrl	7372	MA_SynArp10	4/4	1	130			:
Seq	Genrl	7373	MA_SynArp11	4/4	2	130			:
Seq	Genrl	7374	MA_SynArp12	4/4	1	90			:
Seq	Genrl	7375	MA_SynArp13	4/4	2	124			:
Seq	Genrl	7376	MA_SynArp14	4/4	1	130			:
Seq	Genrl	7377	MA_SynArp15	4/4	1	130			:
Seq	Genrl	7378	MA_SynArp16	4/4	1	130			:
Seq	Genrl	7379	MA_SynArp17	4/4	1	90			:
Seq	Genrl	7380	MA_SynArp18	4/4	1	130			:
Seq	Genrl	7381	MA_SynArp19	4/4	1	120			:

Main Category	Sub Category	ARP No.	ARP Name	Time Signature	Length	Original Tempo	Accent	Random SFX	Voice Type
Seq	Genrl	7382	MA_SynArp20	4/4	1	120			Syn Comp/Lead
Seq	Genrl	7383	MA_SynArp21	4/4	1	124			:
Seq	Genrl	7384	MA_SynArp22	4/4	1	120			:
Seq	Genrl	7385	MA_SynArp23	4/4	1	138			:
Seq	Genrl	7386	MA_SynArp24	4/4	1	138			:
Seq	Genrl	7387	MA_SynArp25	4/4	1	120			:
Seq	Genrl	7388	MA_SynArp26	4/4	1	120			:
Seq	Genrl	7389	MA_SynArp27	4/4	1	120			:
Seq	Genrl	7390	MA_SynArp28	1/4	10	125			:
Seq	Genrl	7391	MA_SynArp29	4/4	5	120			:
Seq	Genrl	7392	MA_Melody1	4/4	1	70			:
Seq	Genrl	7393	MA_Melody2	4/4	1	120			:
Seq	Genrl	7394	MA_Melody3	4/4	1	70			:
Seq	Genrl	7395	MA_Melody4	4/4	1	70			:
Seq	Genrl	7396	MA_Melody5	4/4	1	70			:
Seq	Genrl	7397	MA_Melody6	4/4	1	70			:
Seq	Genrl	7398	MA_Melody7	4/4	1	70			:
Seq	Genrl	7399	MA_Melody8	4/4	1	70			:
Seq	Genrl	7400	MA_Melody9	4/4	1	70			:
Seq	Genrl	7401	MA_Melody10	4/4	1	70			:
Seq	Genrl	7402	MA_Melody11	4/4	1	70			:
Seq	Genrl	7403	MA_Melody12	4/4	1	70			:
Seq	Genrl	7404	MA_Melody13	4/4	1	70			:
Seq	Genrl	7405	MA_Melody14	4/4	1	70			:
Seq	Genrl	7406	MA_Melody15	4/4	1	70			:
Seq	Genrl	7407	MA_Melody16	4/4	1	70			:
Seq	Genrl	7408	MA_Melody17	4/4	1	70			:
Seq	Genrl	7409	MA_Melody17 AF1	4/4	1	119			:
Seq	Genrl	7410	MA_Melody17 AF2	4/4	1	119			:
Seq	Genrl	7411	MA_Melody18	4/4	1	70			:
Seq	Genrl	7412	MA_Melody19	4/4	1	70			:
Seq	Genrl	7413	MA_Melody20	4/4	1	70			:
Seq	Genrl	7414	MA_Melody21	4/4	1	70			:
Seq	Genrl	7415	MA_Melody22	4/4	1	70			:
Seq	Genrl	7416	MA_Melody23	4/4	1	70			:
Seq	Genrl	7417	MA_Melody24	4/4	1	70			:
Seq	Genrl	7418	MA_Melody25	4/4	1	70			:
Seq	Genrl	7419	MA_Melody26	4/4	1	70			:
Seq	Genrl	7420	MA_Melody27	4/4	1	70			:
Seq	Genrl	7421	MA_SynthPhrase1_XS	4/4	1	70			:
Seq	Genrl	7422	MA_SynthPhrase2_XS	4/4	1	70			:
Seq	Genrl	7423	MA_SynthPhrase3_XS	4/4	1	70			:
Seq	Genrl	7424	MA_SynthPhrase4_XS	4/4	1	70			:
Seq	Genrl	7425	MA_SynthPhrase5_XS	4/4	1	70			:
Seq	Genrl	7426	MA_SynthPhrase6_XS	4/4	1	70			:
Seq	Genrl	7427	MA_SynthPhrase7_XS	4/4	1	70			:
Seq	Genrl	7428	MA_SynthPhrase8_XS	4/4	1	70			:
Seq	Genrl	7429	MA_SynthPhrase9_XS	4/4	1	70			:
Seq	Genrl	7430	MA_SynthPhras10_XS	4/4	1	70			:
Seq	Genrl	7431	MA_SynthPhras11_XS	4/4	1	70			:
Seq	Genrl	7432	MA_SynthPhras12_XS	4/4	1	70			:
Seq	Genrl	7433	MA_SynthPhras13_XS	4/4	1	130			:
Seq	Genrl	7434	MA_SynthPhras14_XS	4/4	1	130			:
Seq	Genrl	7435	MA_SynthPhras15_XS	4/4	1	130			:
Seq	Genrl	7436	MA_SynthPhras16_XS	4/4	1	130			:
Seq	Genrl	7437	MA_SynthPhras17_XS	4/4	1	130			:
Seq	Genrl	7438	MA_SynthPhras18_XS	4/4	1	130			:
Seq	Genrl	7439	MA_SynthPhras19_XS	4/4	1	130			:
Seq	Genrl	7440	MA_SynthPhras20_XS	4/4	1	130			:
Seq	Genrl	7441	MA_SynthPhras21_XS	4/4	1	130			:
Seq	Genrl	7442	MA_SynthPhras22_XS	4/4	1	130			:
Seq	Genrl	7443	MA_SynthPhras23_XS	4/4	1	130			:
Seq	Genrl	7444	MA_SynthPhras24_XS	4/4	1	130			:
Seq	Genrl	7445	MA_SynthPhras25_XS	4/4	1	130			:
Seq	Genrl	7446	MA_SynthPhras26_XS	4/4	1	130			:
Seq	Genrl	7447	MA_SynthPhras27_XS	4/4	1	130			:
Seq	Genrl	7448	MA_SynthPhras28_XS	4/4	1	130			:
Seq	Genrl	7449	MA_SynthPhras29_XS	4/4	1	130			:
Seq	Genrl	7450	MA_SynthPhras30_XS	4/4	1	130			:
Seq	Genrl	7451	MA_SynthPhras31_XS	4/4	1	130			:
Seq	Genrl	7452	MA_SynthPhras32_XS	4/4	1	130			:
Seq	Genrl	7453	MA_SynthPhras33_XS	4/4	1	130			:
Seq	Genrl	7454	MA_SynthPhras34_XS	4/4	1	140			:
Seq	Genrl	7455	MA_SynthPhras35_XS	4/4	1	130			:
Seq	Genrl	7456	MA_SynthPhras36_XS	4/4	1	130			:
Seq	Genrl	7457	MA_SynthPhras37_XS	4/4	1	130			:
Seq	Genrl	7458	MA_SynthPhras38_XS	4/4	1	130			:
Seq	Genrl	7459	MA_SynthPhras39_XS	4/4	1	130			:
Seq	Genrl	7460	MA_SynthPhras40_XS	4/4	1	120			:
Seq	Genrl	7461	MA_SynthPhras41_XS	4/4	1	120			:
Seq	Genrl	7462	MA_SynthPhras42_XS	4/4	1	140			:
Seq	Genrl	7463	MA_SynthPhras43_XS	4/4	4	140			:
Seq	Genrl	7464	MA_SynthPhras44_XS	4/4	1	136			:

Main Category	Sub Category	ARP No.	ARP Name	Time Signature	Length	Original Tempo	Accent	Random SFX	Voice Type
Seq	Genrl	7465	MA_SynthPhras45_XS	4/4	1	136			Syn Comp/Lead
Seq	Genrl	7466	MA_SynthPhras46_XS	4/4	2	135			:
Seq	Genrl	7467	MA_SynthPhras47_XS	4/4	1	130			:
Seq	Genrl	7468	MA_SynthPhras48_XS	4/4	1	130			:
Seq	Genrl	7469	MA_SynthPhras49_XS	4/4	1	130			:
Seq	Genrl	7470	MA_SynthPhras50_XS	4/4	1	116			:
Seq	Genrl	7471	MA_SynthPhras51_XS	4/4	1	100			:
Seq	Genrl	7472	MA_SynthPhras52_XS	4/4	1	138			:
Seq	Genrl	7473	MA_Up Oct1	4/4	1	120			:
Seq	Genrl	7474	MA_Up Oct2	4/4	1	120			:
Seq	Genrl	7475	MA_Up Oct3	4/4	1	120			:
Seq	Genrl	7476	MA_Up Oct4	4/4	1	120			:
Seq	Genrl	7477	MA_Down Oct1	4/4	1	120			:
Seq	Genrl	7478	MA_Down Oct2	4/4	1	120			:
Seq	Genrl	7479	MA_Down Oct3	4/4	1	120			:
Seq	Genrl	7480	MA_Down Oct4	4/4	1	120			:
Seq	Genrl	7481	MA_U/D A Oct1	4/4	1	120			:
Seq	Genrl	7482	MA_U/D A Oct2	4/4	1	120			:
Seq	Genrl	7483	MA_U/D A Oct3	4/4	1	120			:
Seq	Genrl	7484	MA_U/D A Oct4	4/4	1	120			:
Seq	Genrl	7485	MA_U/D B Oct1	4/4	1	120			:
Seq	Genrl	7486	MA_U/D B Oct2	4/4	1	120			:
Seq	Genrl	7487	MA_U/D B Oct3	4/4	1	120			:
Seq	Genrl	7488	MA_U/D B Oct4	4/4	1	120			:
Seq	Genrl	7489	MA_Random Oct1	4/4	1	120			:
Seq	Genrl	7490	MA_Random Oct2	4/4	1	120			:
Seq	Genrl	7491	MA_Random Oct3	4/4	1	120			:
Seq	Genrl	7492	MA_Random Oct4	4/4	1	120			:
Seq	Genrl	7493	MA_Oct2 Up	4/4	1	120			:
Seq	Genrl	7494	MA_Oct4 Up	4/4	1	120			:
Seq	Genrl	7495	MA_Unison Up	4/4	1	120			:
Seq	Genrl	7496	MA_Up&Alt1	4/4	1	120			:
Seq	Genrl	7497	MA_Up&Down1	4/4	1	120			:
Seq	Genrl	7498	MA_Up&Down2	4/4	1	120			:
Seq	Genrl	7499	MA_Up&Down3	4/4	1	120			:
Seq	Genrl	7500	MA_Up&Down4	4/4	1	120			:
Seq	Genrl	7501	MA_Up&Random1	4/4	1	120			:
Seq	Genrl	7502	MA_Up&Random2	4/4	1	120			:
Seq	Genrl	7503	MA_Up&Random3	4/4	1	120			:
Seq	Genrl	7504	MA_Up&Random4	4/4	1	120			:
Seq	Genrl	7505	MA_Oct Seq1	4/4	1	130			:
Seq	Genrl	7506	MA_Oct Seq2	4/4	1	130			:
Seq	Genrl	7507	MA_Oct Seq3	4/4	1	130			:
Seq	Genrl	7508	MA_Oct Seq4	4/4	1	130			:
Seq	Genrl	7509	MA_Oct Seq5	4/4	1	130			:
Seq	Genrl	7510	MA_Oct Seq6	4/4	1	90			:
Seq	Genrl	7511	MA_Oct Seq7	4/4	1	90			:
Seq	Genrl	7512	MA_Oct Seq8	4/4	1	90			:
Seq	Genrl	7513	MA_Random Seq1	4/4	1	90			:
Seq	Genrl	7514	MA_Random Seq2	4/4	1	90			:
Seq	Genrl	7515	MA_Random Seq3	4/4	1	90			:
Seq	Genrl	7516	MA_RndmNotesSeq	4/4	1	70			:
Seq	Genrl	7517	MA_Vel Gruv1	4/4	1	134			:
Seq	Genrl	7518	MA_Vel Gruv2	4/4	1	134			:
Seq	Genrl	7519	MA_X-Sweep1	4/4	1	140			:
Seq	Genrl	7520	MA_X-Sweep2	4/4	1	140			:
Seq	Genrl	7521	MA_X-Sweep3	4/4	1	140			:
Seq	Genrl	7522	MA_Simple1	4/4	1	130			:
Seq	Genrl	7523	MA_Simple2	4/4	1	130			:
Seq	Genrl	7524	MA_Simple3	4/4	1	130			:
Seq	Genrl	7525	MA_Simple4	4/4	1	130			:
Seq	Genrl	7526	MA_Simple5	4/4	1	130			:
Seq	Genrl	7527	MA_Basic1	4/4	1	130			:
Seq	Genrl	7528	MA_Basic1 AF2	4/4	8	134			:
Seq	Genrl	7529	MA_Basic2	4/4	1	130			:
Seq	Genrl	7530	MA_Basic3	4/4	1	130			:
Seq	Genrl	7531	MA_FifthS01	4/4	1	130			:
Seq	Genrl	7532	MA_FifthS02	4/4	1	130			:
Seq	Genrl	7533	MA_FifthS03	4/4	1	130			:
Seq	Genrl	7534	MA_FifthS04	4/4	1	130			:
Seq	Genrl	7535	MA_FifthS05	4/4	1	130			:
Seq	Genrl	7536	MA_FifthS06	4/4	1	130			:
Seq	Genrl	7537	MA_MuteArp1	4/4	1	120			:
Seq	Genrl	7538	MA_MuteArp2	4/4	1	120			:
Seq	Genrl	7539	MA_MuteLine	4/4	1	134			:
Seq	Genrl	7540	MA_Chodal	4/4	2	150			:
Seq	Genrl	7541	MA_Wavetable8th	4/4	1	120			:
Seq	Genrl	7542	MA_Wavetable16th	4/4	1	90			:
Seq	Genrl	7543	MA_Syn Chord1	4/4	1	130			:
Seq	Genrl	7544	MA_Syn Chord2	4/4	1	90			:
Seq	Genrl	7545	MA_Syn Chord3	4/4	1	120			:
Seq	Genrl	7546	MA_Syn Chord4	4/4	1	130			:
Seq	Genrl	7547	MA_Syn Chord5	4/4	1	130			:

Main Category	Sub Category	ARP No.	ARP Name	Time Signature	Length	Original Tempo	Accent	Random SFX	Voice Type
Seq	Genrl	7548	MA_Syn Chord6	4/4	1	130			Syn Comp/Lead
Seq	Genrl	7549	MA_Syn Chord7	4/4	1	130			:
Seq	Genrl	7550	MA_Syn Chord8	4/4	1	90			:
Seq	Genrl	7551	MA_Syn Chord9	4/4	1	120			:
Seq	Genrl	7552	MA_Syn Chord10	4/4	1	116			:
Seq	Genrl	7553	MA_Syn Chord11	4/4	4	130			:
Seq	Genrl	7554	MA_Syn Chord12	4/4	1	124			:
Seq	Genrl	7555	MA_Syn Chord13	4/4	1	140			:
Seq	Genrl	7556	MA_Syn Chord14	4/4	2	130			:
Seq	Genrl	7557	MA_Syn Chord15	4/4	2	134			:
Seq	Genrl	7558	MA_Syn Chord16	4/4	1	138			:
Seq	Genrl	7559	MA_BassChord1	4/4	2	130			:
Seq	Genrl	7560	MA_BassChord2	4/4	2	130			:
Seq	Genrl	7561	MA_BassChord3	4/4	2	130			:
Seq	Genrl	7562	MA_BassChord4	4/4	2	130			:
Seq	Genrl	7563	MA_BassChord5	4/4	2	130			:
Seq	Genrl	7564	MA_BassChord6	4/4	2	130			:
Seq	Genrl	7565	MA_BassChord7	4/4	2	130			:
Seq	Genrl	7566	MA_BassChord8	4/4	2	130			:
Seq	Genrl	7567	MA_BassChord9	4/4	1	130			:
Seq	Genrl	7568	MA_BassChord10	4/4	1	130			:
Seq	Genrl	7569	MA_BassChord11	4/4	1	130			:
Seq	Genrl	7570	MA_BassChord12	4/4	1	130			:
Seq	Genrl	7571	MA_BassChord13	4/4	2	130			:
Seq	Genrl	7572	MA_BassChord14	4/4	1	130			:
Seq	Genrl	7573	MA_BassChord15	4/4	2	130			:
Seq	Genrl	7574	MA_BassChord16	4/4	1	130			:
Seq	Genrl	7575	MA_BassChord17	4/4	1	130			:
Seq	Genrl	7576	MA_BassChord18	4/4	2	130			:
Seq	Genrl	7577	MA_BassChord19	4/4	1	130			:
Seq	Genrl	7578	MA_BassChord20	4/4	1	130			:
Seq	Genrl	7579	MA_Chord AIB1	4/4	1	120			:
Seq	Genrl	7580	MA_Chord AIB2	4/4	1	120			:
Seq	Genrl	7581	MA_Chord AIB4	4/4	1	120			:
Seq	Genrl	7582	MA_ChordRandom1	4/4	1	120			:
Seq	Genrl	7583	MA_ChordRandom2	4/4	1	120			:
Seq	Genrl	7584	MA_ChordRandom4	4/4	1	120			:
Hybrd	Comb	7585	MA_Hybrid1	4/4	1	130			Syn Comp/Lead/Pad
Hybrd	Comb	7586	MA_Hybrid2	4/4	1	130			:
Hybrd	Comb	7587	MA_Hybrid3	4/4	1	130			:
Hybrd	Comb	7588	MA_Hybrid4	4/4	1	130			:
Hybrd	Comb	7589	MA_Hybrid5	4/4	1	95			:
Hybrd	Comb	7590	MA_Hybrid6	4/4	1	130			:
Hybrd	Comb	7591	MA_Hybrid7	4/4	1	130			:
Hybrd	Comb	7592	MA_Hybrid8	4/4	1	90			:
Hybrd	Comb	7593	MA_Hybrid9	4/4	1	130			:
Hybrd	Comb	7594	MA_Hybrid10	4/4	1	130			:
Hybrd	Comb	7595	MA_Hybrid11	4/4	1	130			:
Hybrd	Comb	7596	MA_Hybrid12	4/4	1	90			:
Hybrd	Comb	7597	MA_Hybrid13	4/4	1	130			:
Hybrd	Comb	7598	MA_Hybrid14	4/4	1	130			:
Hybrd	Comb	7599	MA_Hybrid15	4/4	1	130			:
Hybrd	Comb	7600	MA_Hybrid16	4/4	1	106			:
Hybrd	Comb	7601	MA_Hybrid17	4/4	1	130			:
Hybrd	Comb	7602	MA_Hybrid18	4/4	1	110			:
Hybrd	Comb	7603	MA_Hybrid19	4/4	1	100			:
Hybrd	Comb	7604	MA_Hybrid20	4/4	1	116			:
Hybrd	Comb	7605	MA_Hybrid1CF1	4/4	1	130			:
Hybrd	Comb	7606	MA_Hybrid1CF2	4/4	1	130			:
Hybrd	Comb	7607	MA_Hybrid1CF3	4/4	1	130			:
Hybrd	Comb	7608	MA_Hybrid1CF3 AF1&2	4/4	1	84			:
Hybrd	Comb	7609	MA_Hybrid1CF4	4/4	1	130			:
Hybrd	Comb	7610	MA_Hybrid3 CF	4/4	1	120			:
Hybrd	Comb	7611	MA_Hybrid21CF	4/4	1	100			:
Hybrd	Comb	7612	MA_Hybrid21CF AF1	4/4	1	119			:
Hybrd	Comb	7613	MA_Hybrid21CF AF2	4/4	1	119			:
Hybrd	Comb	7614	MA_Hybrid21CF AF1&2	4/4	1	119			:
Hybrd	Comb	7615	MA_Hybrid22CF	4/4	1	138			:
Hybrd	Comb	7616	MA_Hybrid23CF	4/4	1	130			:
Hybrd	Comb	7617	MA_Hybrid24CF	4/4	1	130			:
Hybrd	Comb	7618	MA_Hybrid24CF AF2	4/4	1	84			:
Hybrd	Comb	7619	MA_Hybrid25CF	4/4	1	96			:
Hybrd	Comb	7620	MA_Parade	4/4	2	120			:
Hybrd	Comb	7621	MA_SynPop Comb1	4/4	4	90			:
Hybrd	Comb	7622	MA_SynPop Comb2	4/4	4	90			:
Hybrd	Comb	7623	MA_Trancy1_ES	4/4	1	140			:
Hybrd	Comb	7624	MA_Trancy2	4/4	4	140			:
Hybrd	Comb	7625	MA_Trancy3	4/4	16	140			:
Hybrd	Zone	7626	MA_2Z_Comb S01	4/4	2	90			:
Hybrd	Zone	7627	MA_2Z_Comb S02	4/4	1	70			:
Hybrd	Zone	7628	MA_2Z_Comb S03	4/4	1	90			:
Hybrd	Zone	7629	MA_2Z_Comb S04	4/4	1	130			:
Hybrd	Zone	7630	MA_2Z_Comb S05	4/4	2	130			:

Arpeggio Type List

Main Category	Sub Category	ARP No.	ARP Name	Time Signature	Length	Original Tempo	Accent	Random SFX	Voice Type
Hybrd	Zone	7631	MA_2Z_Comb SQ6	4/4	2	130			Syn Comp/Lead/Pad
Hybrd	Zone	7632	MA_2Z_Comb SQ7	4/4	1	130			:
Hybrd	Zone	7633	MA_2Z_Comb SQ8	4/4	1	70			:
Hybrd	Zone	7634	MA_2Z_Comb SQ9	4/4	2	130			:
Hybrd	Zone	7635	MA_2Z_Comb SQ10	4/4	2	70			:
Hybrd	Zone	7636	MA_2Z_Comb SQ11	4/4	1	70			:
Hybrd	Zone	7637	MA_2Z_Comb SQ12	4/4	1	70			:
Hybrd	Zone	7638	MA_2Z_Comb SQ13	4/4	2	90			:
Hybrd	Zone	7639	MA_4Z_HybVel1	4/4	1	96			:
Hybrd	Zone	7640	MA_4Z_HybVel2	4/4	1	96			:
Hybrd	Zone	7641	MA_4Z_HybVel3	4/4	1	96			:
Hybrd	Zone	7642	MA_4Z_HybVel4	4/4	1	96			:
Hybrd	Zone	7643	MA_4Z_HybVel5	4/4	1	96			:
Hybrd	Zone	7644	MA_4Z_HybVel6	4/4	1	96			:
Hybrd	Zone	7645	MA_4Z_HybVel7	4/4	1	96			:
Hybrd	Zone	7646	MA_4Z_HybVel7 AF1&2	4/4	1	123			:
Hybrd	Zone	7647	MA_4Z_HybVel8	4/4	1	96			:
Hybrd	Zone	7648	MA_4Z_HybVel9	4/4	2	120			:
Hybrd	Zone	7649	MA_4Z_HybVel10	4/4	2	120			:
Hybrd	Zone	7650	MA_4Z_HybVel11	4/4	2	120			:
Hybrd	Zone	7651	MA_4Z_HybVel12	4/4	2	120			:
Hybrd	Zone	7652	MA_4Z_HybVel13	4/4	2	120			:
Hybrd	Zone	7653	MA_4Z_HybVel14	4/4	2	120			:
Hybrd	Zone	7654	MA_4Z_HybVel15	4/4	2	120			:
Hybrd	Zone	7655	MA_4Z_HybVel16	4/4	2	120			:
Hybrd	Zone	7656	MA_4Z_4zone1A	4/4	2	130			:
Hybrd	Zone	7657	MA_4Z_4zone1B	4/4	2	130			:
Hybrd	Zone	7658	MA_4Z_4zone1C	4/4	2	130			:
Hybrd	Zone	7659	MA_4Z_4zone1D	4/4	2	130			:
Hybrd	Zone	7660	MA_4Z_4zone1E	4/4	2	130			:
Hybrd	Zone	7661	MA_4Z_4zone2A	4/4	1	130			:
Hybrd	Zone	7662	MA_4Z_4zone2B	4/4	1	130			:
Hybrd	Zone	7663	MA_4Z_4zone2C	4/4	1	130			:
Hybrd	Zone	7664	MA_4Z_4zone2D	4/4	1	130			:
Hybrd	Zone	7665	MA_4Z_4zone2E	4/4	1	130			:
Hybrd	Zone	7666	MA_4Z_4zone3A	4/4	1	70			:
Hybrd	Zone	7667	MA_4Z_4zone3B	4/4	1	94			:
Hybrd	Zone	7668	MA_4Z_4zone3C	4/4	1	94			:
Hybrd	Zone	7669	MA_4Z_4zone3D	4/4	1	94			:
Hybrd	Zone	7670	MA_4Z_4zone3E	4/4	1	94			:
Hybrd	Zone	7671	MA_4Z_4zone4A	4/4	1	70			:
Hybrd	Zone	7672	MA_4Z_4zone4B	4/4	1	70			:
Hybrd	Zone	7673	MA_4Z_4zone4C	4/4	1	70			:
Hybrd	Zone	7674	MA_4Z_4zone4D	4/4	1	70			:
Hybrd	Zone	7675	MA_4Z_4zone4E	4/4	1	70			:
Hybrd	Zone	7676	MA_4Z_4zone5A	4/4	1	70			:
Hybrd	Zone	7677	MA_4Z_4zone5B	4/4	1	70			:
Hybrd	Zone	7678	MA_4Z_4zone5C	4/4	1	70			:
Hybrd	Zone	7679	MA_4Z_4zone5D	4/4	1	70			:
Hybrd	Zone	7680	MA_4Z_4zone5E	4/4	1	70			:
Hybrd	Zone	7681	MA_4Z_HybPrc1	4/4	1	130			:
Hybrd	Zone	7682	MA_4Z_HybPrc2	4/4	1	130			:
Hybrd	Zone	7683	MA_4Z_HybPrc3	4/4	1	130			:
Hybrd	Zone	7684	MA_4Z_HybPrc4	4/4	1	130			:
Hybrd	Zone	7685	MA_4Z_HybPrc5	4/4	1	130			:
Hybrd	Zone	7686	MA_4Z_HybPrc6	4/4	1	130			:
Hybrd	Zone	7687	MA_4Z_HybPrc7	4/4	1	130			:
Hybrd	Zone	7688	MA_4Z_HybPrc8	4/4	1	90			:
Hybrd	Zone	7689	MA_4Z_HybPrc9	4/4	1	90			:
Hybrd	Zone	7690	MA_4Z_HybPrc10	4/4	1	90			:
Hybrd	Zone	7691	MA_4Z_Ice 1_ES	1/4	4	130			:
Hybrd	Zone	7692	MA_4Z_Ice 2_ES	1/4	8	130			:
Hybrd	Zone	7693	MA_4Z_Ice 3	1/4	4	140			:
Hybrd	Zone	7694	MA_4Z_Ice 4	1/4	8	130			:
Hybrd	Zone	7695	MA_4Z_Ice 5	1/4	8	130			:
Hybrd	Zone	7696	MA_4Z_Ice 6	1/4	8	130			:
Hybrd	Zone	7697	MA_4Z_Ice 7	1/4	8	130			:
Hybrd	Zone	7698	MA_4Z_Ice 8_ES	1/4	8	130			:
Hybrd	Zone	7699	MA_4Z_Ice 9_ES	1/4	4	140			:
Hybrd	Zone	7700	MA_4Z_Ice 10	1/4	4	140			:
Hybrd	Zone	7701	MA_4Z_RndmBeat1	4/4	8	90			:
Hybrd	Zone	7702	MA_4Z_RndmBeat2	4/4	8	90			:
Hybrd	Zone	7703	MA_4Z_RndmBeat3	4/4	2	90			:
Hybrd	Zone	7704	MA_4Z_RndmBeat4	4/4	2	90			:
Hybrd	Zone	7705	MA_4Z_RndmBeat5	4/4	2	90			:
Hybrd	Zone	7706	MA_4Z_RndmBeat6	4/4	8	90			:
Hybrd	Zone	7707	MA_4Z_RndmBeat7	4/4	8	90			:
Hybrd	Zone	7708	MA_4Z_Bend	4/4	1	120			:
Hybrd	Zone	7709	MA_8Z_8ZoneArp 1A	4/4	1	56			:
Hybrd	Zone	7710	MA_8Z_8ZoneArp 1B	4/4	1	56			:
Hybrd	Zone	7711	MA_8Z_8ZoneArp 1C	4/4	1	56			:
Hybrd	Zone	7712	MA_8Z_8ZoneArp 1D	4/4	1	56			:
Hybrd	Zone	7713	MA_8Z_8ZoneArp 1E	4/4	1	56			:

Main Category	Sub Category	ARP No.	ARP Name	Time Signature	Length	Original Tempo	Accent	Random SFX	Voice Type
Hybrd	Zone	7714	MA_8Z_8ZoneArpH 1A	4/4	2	112			Syn Comp/Lead/Pad
Hybrd	Zone	7715	MA_8Z_8ZoneArpH 1B	4/4	2	112			:
Hybrd	Zone	7716	MA_8Z_8ZoneArpH 1C	4/4	2	112			:
Hybrd	Zone	7717	MA_8Z_8ZoneArpH 1D	4/4	2	112			:
Hybrd	Zone	7718	MA_8Z_8ZoneArpH 1E	4/4	2	112			:
Hybrd	Zone	7719	MA_8Z_8ZoneArp 2A	4/4	1	112			:
Hybrd	Zone	7720	MA_8Z_8ZoneArp 2B	4/4	1	112			:
Hybrd	Zone	7721	MA_8Z_8ZoneArp 2C	4/4	1	112			:
Hybrd	Zone	7722	MA_8Z_8ZoneArp 2D	4/4	1	112			:
Hybrd	Zone	7723	MA_8Z_8ZoneArp 2E	4/4	1	112			:
Hybrd	Zone	7724	MA_8Z_8ZoneArp 3A	4/4	1	140			:
Hybrd	Zone	7725	MA_8Z_8ZoneArp 3B	4/4	1	140			:
Hybrd	Zone	7726	MA_8Z_8ZoneArp 3C	4/4	1	140			:
Hybrd	Zone	7727	MA_8Z_8ZoneArp 3D	4/4	1	140			:
Hybrd	Zone	7728	MA_8Z_8ZoneArp 3E	4/4	1	140			:
Hybrd	Z.Pad	7729	MA_PadL_Pad SeqL1	4/4	2	108			:
Hybrd	Z.Pad	7730	MA_PadL_Pad SeqL2	4/4	2	104			:
Hybrd	Z.Pad	7731	MA_PadL_Pad SeqL3	4/4	2	104			:
Hybrd	Z.Pad	7732	MA_PadL_Pad SeqL4	4/4	2	104			:
Hybrd	Z.Pad	7733	MA_PadL_Pad SeqL5	4/4	1	108			:
Hybrd	Z.Pad	7734	MA_PadL_Pad SeqL6	4/4	2	90			:
Hybrd	Z.Pad	7735	MA_PadL_Pad SeqL7	4/4	2	90			:
Hybrd	Z.Pad	7736	MA_PadL_Pad SeqL8	4/4	1	90			:
Hybrd	Z.Pad	7737	MA_PadL_Pad SeqL9	4/4	1	90			:
Hybrd	Z.Pad	7738	MA_PadL_Pad SeqL10	4/4	1	145			:
Hybrd	Z.Pad	7739	MA_PadL_Pad SeqL11	4/4	1	130			:
Hybrd	Z.Pad	7740	MA_PadL_Pad SeqL12	4/4	2	130			:
Hybrd	Z.Pad	7741	MA_PadL_Pad SeqL13	4/4	1	90			:
Hybrd	Z.Pad	7742	MA_PadL_Pad SeqL14	4/4	1	90			:
Hybrd	Z.Pad	7743	MA_PadH_Pad Seq1	4/4	1	70			:
Hybrd	Z.Pad	7744	MA_PadH_Pad Seq2	4/4	1	70			:
Hybrd	Z.Pad	7745	MA_PadH_Pad Seq3	4/4	1	70			:
Hybrd	Z.Pad	7746	MA_PadH_Pad Seq4	4/4	1	90			:
Hybrd	Z.Pad	7747	MA_PadH_Pad Seq5	4/4	1	124			:
Hybrd	Z.Pad	7748	MA_PadH_Pad Seq6	4/4	1	56			:
Hybrd	Z.Pad	7749	MA_PadH_Pad Seq7	4/4	2	145			:
Hybrd	Z.Pad	7750	MA_PadH_Pad Seq8	4/4	2	145			:
Hybrd	Z.Pad	7751	MA_PadH_Pad Seq9	4/4	1	145			:
Hybrd	Z.Pad	7752	MA_PadH_Pad Seq10	4/4	2	145			:
Hybrd	Z.Pad	7753	MA_PadH_Pad Seq11	4/4	2	145			:
Hybrd	Z.Pad	7754	MA_PadH_Pad Seq12	4/4	2	145			:
Hybrd	Z.Pad	7755	MA_PadH_Pad Seq13	4/4	2	145			:
Hybrd	Z.Pad	7756	MA_PadH_Pad Seq14	4/4	1	145			:
Hybrd	Z.Pad	7757	MA_PadH_Pad Seq15	4/4	2	145			:
Hybrd	Z.Pad	7758	MA_PadH_Pad Seq16	4/4	2	145			:
Hybrd	Z.Pad	7759	MA_PadH_Pad Seq17	4/4	2	145			:
Hybrd	Z.Pad	7760	MA_PadH_Pad Seq18	4/4	1	145			:
Hybrd	Z.Pad	7761	MA_PadH_Pad Seq19	4/4	1	145			:
Cntr	Filtr	7762	Gate Cut1	4/4	4	120			(CC#10,71,74)
Cntr	Filtr	7763	Gate Cut2	4/4	1	120			(CC#74)
Cntr	Filtr	7764	Gate Cut3	4/4	8	120			(CC#71,74)
Cntr	Filtr	7765	CC-Dive1	4/4	4	130			:
Cntr	Filtr	7766	CC-Dive2	4/4	2	130			:
Cntr	Filtr	7767	FilterWave1	4/4	4	105			:
Cntr	Filtr	7768	FilterWave2	4/4	4	105			:
Cntr	Filtr	7769	Filter 16	4/4	1	153			(CC#74)
Cntr	Filtr	7770	Filter 32	4/4	1	153			:
Cntr	Filtr	7771	Filter 3to3	4/4	2	153			:
Cntr	Filtr	7772	Filter3Delay	4/4	1	153			:
Cntr	Filtr	7773	Filter Fill1	4/4	1	153			:
Cntr	Filtr	7774	Filter Fill2	4/4	1	153			:
Cntr	Filtr	7775	Filter Fill3	4/4	1	153			:
Cntr	Filtr	7776	Filter Fill4	4/4	1	153			:
Cntr	Filtr	7777	MC_Hip Hop 2	4/4	2	94			(CC#71,74)
Cntr	Filtr	7778	FB_Hip Hop 2	4/4	1	94			:
Cntr	Filtr	7779	IA_Trance 5_ES	4/4	4	140			(CC#74)
Cntr	Filtr	7780	MA_Acid Breaks	4/4	1	98			(CC#10,74)
Cntr	Filtr	7781	IA_Dream Dance	4/4	4	136			(CC#74)
Cntr	Filtr	7782	MC_Club House	4/4	2	128			(CC#71,74)
Cntr	Filtr	7783	FA_Club House	4/4	1	128			(CC#71)
Cntr	Filtr	7784	MB_Garage 2	4/4	2	127			(CC#74)
Cntr	Filtr	7785	MC_Garage 2	4/4	2	127			:
Cntr	Filtr	7786	FA_Garage 2	4/4	1	127			:
Cntr	Filtr	7787	MA_Chill Out	4/4	2	79			:
Cntr	Filtr	7788	MD_Chill Out	4/4	2	79			(CC#11,74)
Cntr	Filtr	7789	IA_Chill Out	4/4	4	79			(CC#74)
Cntr	Filtr	7790	FB_Chill Out						

Main Category	Sub Category	ARP No.	ARP Name	Time Signature	Length	Original Tempo	Accent	Random SFX	Voice Type
Cntr	Filtr	7797	MC_Ambient 3	4/4	2	75			(CC#71,74)
Cntr	Filtr	7798	MC_Ambient 3 AF1	4/4	2	75			:
Cntr	Filtr	7799	MC_Ambient 3 AF2	4/4	2	75			:
Cntr	Filtr	7800	Wobble 1	4/4	1	120			(CC#74)
Cntr	Filtr	7801	Wobble 2	4/4	1	120			:
Cntr	Filtr	7802	Wobble 3	4/4	1	120			:
Cntr	Filtr	7803	Wobble 4	4/4	2	120			:
Cntr	Filtr	7804	Wobble 5	4/4	2	120			(CC#10,11,74)
Cntr	Exprs	7805	GateL1	4/4	1	134			(CC#11)
Cntr	Exprs	7806	GateL2	4/4	1	134			:
Cntr	Exprs	7807	GateL3	4/4	1	134			:
Cntr	Exprs	7808	GateL4	4/4	1	134			:
Cntr	Exprs	7809	GateL5	4/4	1	134			:
Cntr	Exprs	7810	GateL6	4/4	1	134			:
Cntr	Exprs	7811	GateL7	4/4	1	134			:
Cntr	Exprs	7812	GateL8	4/4	1	134			:
Cntr	Exprs	7813	GateL9	4/4	1	134			:
Cntr	Exprs	7814	GateL10	4/4	1	134			:
Cntr	Exprs	7815	GateL11	4/4	1	134			:
Cntr	Exprs	7816	GateL12	4/4	1	134			:
Cntr	Exprs	7817	GateL13	4/4	1	134			:
Cntr	Exprs	7818	GateL14	4/4	1	134			:
Cntr	Exprs	7819	GateL15	4/4	1	134			:
Cntr	Exprs	7820	GateL16	4/4	1	134			:
Cntr	Exprs	7821	GateL17	4/4	1	134			:
Cntr	Exprs	7822	GateL18	4/4	1	134			:
Cntr	Exprs	7823	GateL19	4/4	1	134			:
Cntr	Exprs	7824	GateL20	4/4	1	134			:
Cntr	Exprs	7825	GateM1	4/4	1	134			:
Cntr	Exprs	7826	GateM2	4/4	1	134			:
Cntr	Exprs	7827	GateM3	4/4	1	134			:
Cntr	Exprs	7828	GateM4	4/4	1	134			:
Cntr	Exprs	7829	GateM5	4/4	1	134			:
Cntr	Exprs	7830	GateM6	4/4	1	134			:
Cntr	Exprs	7831	GateM7	4/4	1	134			:
Cntr	Exprs	7832	GateM8	4/4	1	134			:
Cntr	Exprs	7833	GateM9	4/4	1	134			:
Cntr	Exprs	7834	GateM10	4/4	1	134			:
Cntr	Exprs	7835	GateM11	4/4	1	134			:
Cntr	Exprs	7836	GateM12	4/4	1	134			:
Cntr	Exprs	7837	GateM13	4/4	1	134			:
Cntr	Exprs	7838	GateM14	4/4	1	134			:
Cntr	Exprs	7839	GateM15	4/4	1	134			:
Cntr	Exprs	7840	GateM16	4/4	1	134			:
Cntr	Exprs	7841	GateM17	4/4	1	134			:
Cntr	Exprs	7842	GateM18	4/4	1	134			:
Cntr	Exprs	7843	GateM19	4/4	1	134			:
Cntr	Exprs	7844	GateM20	4/4	1	134			:
Cntr	Exprs	7845	GateS1	4/4	1	134			:
Cntr	Exprs	7846	GateS2	4/4	1	134			:
Cntr	Exprs	7847	GateS3	4/4	1	134			:
Cntr	Exprs	7848	GateS4	4/4	1	134			:
Cntr	Exprs	7849	GateS5	4/4	1	134			:
Cntr	Exprs	7850	GateS6	4/4	1	134			:
Cntr	Exprs	7851	GateS7	4/4	1	134			:
Cntr	Exprs	7852	GateS8	4/4	1	134			:
Cntr	Exprs	7853	GateS9	4/4	1	134			:
Cntr	Exprs	7854	GateS10	4/4	1	134			:
Cntr	Exprs	7855	GateS11	4/4	1	134			:
Cntr	Exprs	7856	GateS12	4/4	1	134			:
Cntr	Exprs	7857	GateS13	4/4	1	134			:
Cntr	Exprs	7858	GateS14	4/4	1	134			:
Cntr	Exprs	7859	GateS15	4/4	1	134			:
Cntr	Exprs	7860	GateS16	4/4	1	134			:
Cntr	Exprs	7861	GateS17	4/4	1	134			:
Cntr	Exprs	7862	GateS18	4/4	1	134			:
Cntr	Exprs	7863	GateS19	4/4	1	134			:
Cntr	Exprs	7864	GateS20	4/4	1	134			:
Cntr	Exprs	7865	LevSawDown	4/4	1	90			:
Cntr	Exprs	7866	SlicePhrase1	4/4	1	153			:
Cntr	Exprs	7867	SlicePhrase2	4/4	1	153			:
Cntr	Exprs	7868	SlicePhrase3	4/4	1	153			:
Cntr	Exprs	7869	SlicePhrase4	4/4	1	153			:
Cntr	Exprs	7870	SlicePhrase5	4/4	4	153			:
Cntr	Exprs	7871	SlicePhrase6	4/4	4	153			:
Cntr	Exprs	7872	SlicePhrase7	4/4	4	153			:
Cntr	Exprs	7873	SlicePhrase8	4/4	4	153			:
Cntr	Exprs	7874	Slice 16	4/4	1	153			:
Cntr	Exprs	7875	Slice 32	4/4	1	155			:
Cntr	Exprs	7876	Slice to3	4/4	1	153			:
Cntr	Exprs	7877	Slice 3Delay	4/4	1	153			:
Cntr	Exprs	7878	Slice Fill1	4/4	1	153			:
Cntr	Exprs	7879	Slice Fill2	4/4	2	153			:

Main Category	Sub Category	ARP No.	ARP Name	Time Signature	Length	Original Tempo	Accent	Random SFX	Voice Type
Cntr	Exprs	7880	Slice Fill3	4/4	2	153			(CC#11)
Cntr	Exprs	7881	Slice Fill4	4/4	2	153			:
Cntr	Exprs	7882	MA_Dream Trance	4/4	1	140			:
Cntr	Exprs	7883	MA_Dream Trance AF1	4/4	1	140			:
Cntr	Exprs	7884	MB_Dream Trance	4/4	1	140			:
Cntr	Exprs	7885	MB_Dream Trance AF2	4/4	1	140			:
Cntr	Exprs	7886	Pumping&Notes S	4/4	1	120			:
Cntr	Exprs	7887	Pumping&Notes M	4/4	1	120			:
Cntr	Exprs	7888	Pumping&Notes L	4/4	1	120			:
Cntr	Exprs	7889	Pumping&Notes P	4/4	1	120			(CC#10,11)
Cntr	Exprs	7890	PumpingCtrl S	4/4	1	120			(CC#11)
Cntr	Exprs	7891	PumpingCtrl M	4/4	1	120			:
Cntr	Exprs	7892	PumpingCtrl L	4/4	1	120			:
Cntr	Exprs	7893	PumpingCtrl P	4/4	1	120			(CC#10,11)
Cntr	Pan	7894	Pan Etx4CRL	4/4	1	153			(CC#10)
Cntr	Pan	7895	Pan Etx4LCR	4/4	1	153			:
Cntr	Pan	7896	Pan Etx4RLC	4/4	1	153			:
Cntr	Pan	7897	Pan Etx8+LR	4/4	1	153			:
Cntr	Pan	7898	Pan Etx16CRL	4/4	1	153			:
Cntr	Pan	7899	Pan Etx16RL	4/4	1	153			:
Cntr	Pan	7900	Pan Etx16RL-C	4/4	1	153			:
Cntr	Pan	7901	Pan 16RL-WRL	4/4	2	153			:
Cntr	Pan	7902	MB_Hip Hop 2	4/4	2	94			:
Cntr	Pan	7903	MB_New Gospel	4/4	2	90			(CC#10,11)
Cntr	Pan	7904	MC_New Gospel	4/4	2	90			:
Cntr	Pan	7905	IA_New Gospel	4/4	1	90			:
Cntr	Pan	7906	IA_Club House	4/4	2	128			(CC#10)
Cntr	Mod	7907	Mod Control	4/4	4	64			(CC#1)
Cntr	Mod	7908	Mod ControlU	4/4	4	90			:
Cntr	Pbend	7909	Benid Vibrato	4/4	4	120			(PB, PB Range=12)
Cntr	Pbend	7910	BottleDwVib	4/4	4	120			:
Cntr	Pbend	7911	BottleUpVib	4/4	4	120			:
Cntr	Pbend	7912	HammerVib	4/4	4	120			:
Cntr	Pbend	7913	PullingVib1	4/4	4	120			:
Cntr	Pbend	7914	PullingVib2	4/4	4	120			:
Cntr	Pbend	7915	SlideVibrato	4/4	4	120			:
Cntr	Pbend	7916	U/D ChoknVib	4/4	4	120			:
Cntr	Pbend	7917	Trill 4	4/4	4	120			:
Cntr	Pbend	7918	Trill 5	4/4	4	120			:
Cntr	Pbend	7919	Vibrato1	4/4	4	120			:
Cntr	Pbend	7920	Vibrato2	4/4	4	120			:
Cntr	Pbend	7921	Choking Vib	4/4	4	120			:
Cntr	Pbend	7922	Arm Down	4/4	4	120			:
Cntr	Pbend	7923	ThrobFx	4/4	4	100			(PB, PB Range=24)
Cntr	Pbend	7924	PitchEffect1	4/4	1	153			:
Cntr	Pbend	7925	PitchEffect2	4/4	1	153			:
Cntr	Pbend	7926	PitchEffect3	4/4	1	153			:
Cntr	Pbend	7927	PitchEffect4	4/4	1	153			:
Cntr	Pbend	7928	PitchEffect5	4/4	1	153			(PB, PB Range=12)
Cntr	Pbend	7929	PitchEffect6	4/4	1	153			(PB, PB Range=24)
Cntr	Pbend	7930	PitchEffect7	4/4	1	153			:
Cntr	Pbend	7931	PitchEffect8	4/4	2	153			:
Cntr	Assign	7932	AS1Env1	4/4	1	90			(CC#16)
Cntr	Assign	7933	AS1Env2	4/4	1	90			:
Cntr	Assign	7934	AS1Env3	4/4	1	90			:
Cntr	Assign	7935	AS1Env4	4/4	1	90			:
Cntr	Assign	7936	AS1Env5	4/4	1	90			:
Cntr	Assign	7937	AS1Env6	4/4	1	90			:
Cntr	Assign	7938	AS1Env7	4/4	1	90			:
Cntr	Assign	7939	AS1Env8	4/4	1	90			:
Cntr	Assign	7940	AS1Tri+1	4/4	1	150			:
Cntr	Assign	7941	AS1Tri-1	4/4	1	90			:
Cntr	Assign	7942	AS1TriF1	4/4	1	90			:
Cntr	Assign	7943	AS1Tri+4	4/4	1	90			:
Cntr	Assign	7944	AS1Tri-4	4/4	4	90			:
Cntr	Assign	7945	AS1TriF4	4/4	4	90			:
Cntr	Assign	7946	AS1Tri+8	4/4	8	90			:
Cntr	Assign	7947	AS1Tri-8	4/4	8	90			:
Cntr	Assign	7948	AS1TriF8	4/4	8	90			:
Cntr	Assign	7949	AS1Up+1	4/4	1	90			:
Cntr	Assign	7950	AS1Dw+1	4/4	1	90			:
Cntr	Assign	7951	AS1SawDw	4/4	1	90			:
Cntr	Assign	7952	AS2Env1	4/4	1	90			(CC#17)
Cntr	Assign	7953	AS2Env2	4/4	1	90			:
Cntr	Assign	7954	AS2Env3	4/4	1	90			:
Cntr	Assign	7955	AS2Env4	4/4	1	90			:
Cntr	Assign	7956	AS2Env5	4/4	1	90			:
Cntr	Assign	7957	AS2Env6	4/4	1	90			:
Cntr	Assign	7958	AS2Env7	4/4	1	90			:
Cntr	Assign	7959	AS2Env8	4/4	1	90			:
Cntr	Assign	7960	AS2Tri+1	4/4	1	90			:
Cntr	Assign	7961	AS2Tri-1	4/4	1	90			:
Cntr	Assign	7962	AS2TriF1	4/4	1	90			:

Main Category	Sub Category	ARP No.	ARP Name	Time Signature	Length	Original Tempo	Accent	Random SFX	Voice Type
Cntr	Assign	7963	AS2Tri+4	4 / 4	1	90			(CC#17)
Cntr	Assign	7964	AS2Tri-4	4 / 4	4	90			:
Cntr	Assign	7965	AS2TriF4	4 / 4	4	90			:
Cntr	Assign	7966	AS2Tri+8	4 / 4	1	90			:
Cntr	Assign	7967	AS2Tri-8	4 / 4	8	90			:
Cntr	Assign	7968	AS2TriF8	4 / 4	8	90			:
Cntr	Assign	7969	AS2Up+1	4 / 4	1	90			:
Cntr	Assign	7970	AS2Dw+1	4 / 4	1	90			:
Cntr	Assign	7971	AS2SawDw	4 / 4	1	90			:
Cntr	Assign	7972	MA_Acid Breaks	4 / 4	1	98			:
Cntr	Assign	7973	MB_Acid Breaks	4 / 4	4	98			(CC#10,17,74)
Cntr	Genrl	7974	Mute 4/4	4 / 4	1	120			(no event)
Cntr	Genrl	7975	Mute 2/4	2 / 4	1	120			:
Cntr	Genrl	7976	Mute 3/4	3 / 4	1	120			:
Cntr	Genrl	7977	Mute 5/4	5 / 4	1	120			:
Cntr	Genrl	7978	Mute 6/4	6 / 4	1	120			:
Cntr	Genrl	7979	Mute 6/8	6 / 8	1	120			:
Cntr	Genrl	7980	Mute 3/8	3 / 8	1	120			:
Cntr	Genrl	7981	Mute 9/8	9 / 8	1	120			:

(*contents provided by Keyfax New Media — www.keyfax.com)

Effect Type List

Category	Category (Display)	Effect Type Name	Type (HEX)		MOXF6/MOXF8					
			MSB	LSB	Rev	Cho	InsA	InsB	InsL	Mas
	—	NO EFFECT	0	0	○	○				
	—	THRU	0	0			○	○	○	
REVERB										
	REV	REV-X HALL	1	0	○					
	REV	R3 HALL	1	1	○					
	REV	SPX HALL	1	2	○	○	○	○		
	REV	REV-X ROOM	1	10	○					
	REV	R3 ROOM	1	11	○					
	REV	SPX ROOM	1	12	○	○	○	○		
	REV	R3 PLATE	1	20	○					
	REV	SPX STAGE	1	30	○	○	○	○		
	REV	SPACE SIMULATOR	1	40	○					
DELAY										
	DLY	CROSS DELAY	2	0		○	○	○		
	DLY	TEMPO CROSS DELAY	2	10		○	○	○		
	DLY	TEMPO DELAY MONO	2	20		○	○	○		
	DLY	TEMPO DELAY STEREO	2	28		○	○	○		
	DLY	CONTROL DELAY	2	30			○	○		
	DLY	DELAY LR	2	40		○	○	○		
	DLY	DELAY LCR	2	50		○	○	○		
	DLY	DELAY LR (Stereo)	2	48		○	○	○		○
CHORUS										
	CHO	G CHORUS	3	0		○	○	○		
	CHO	2 MODULATOR	3	10		○	○	○		
	CHO	SPX CHORUS	3	20		○	○	○		
	CHO	SYMPHONIC	3	30		○	○	○		
	CHO	ENSEMBLE DETUNE	3	40		○	○	○		
FLANGER										
	FLG	VCM FLANGER	4	0		○	○	○		
	FLG	CLASSIC FLANGER	4	10		○	○	○		
	FLG	TEMPO FLANGER	4	20		○	○	○		
	FLG	DYNAMIC FLANGER	4	30			○	○		
PHASER										
	PHA	VCM PHASER MONO	5	0		○	○	○		
	PHA	VCM PHASER STEREO	5	10		○	○	○		
	PHA	TEMPO PHASER	5	20		○	○	○		
	PHA	DYNAMIC PHASER	5	30			○	○		
TOREMOLO&ROTARY										
	T&R	AUTO PAN	6	0			○	○		
	T&R	TREMOLO	6	10			○	○		
	T&R	ROTARY SPEAKER	6	20			○	○		
DISTORTION										
	DST	AMP SIMULATOR 1	7	0			○	○		
	DST	AMP SIMULATOR 2	7	10			○	○		
	DST	COMP DISTORTION	7	20			○	○		
	DST	COMP DISTORTION DELAY	7	30			○	○		○
COMPRESSOR										
	CMP	VCM COMPRESSOR 376	8	0			○	○		○
	CMP	CLASSIC COMPRESSOR	8	10			○	○		
	CMP	MULTI BAND COMP	8	20			○	○		○
WAH										
	WAH	VCM AUTO WAH	0A	0			○	○		
	WAH	VCM TOUCH WAH	0A	10			○	○		
	WAH	VCM PEDAL WAH	0A	20			○	○		
LO-FI										
	L-F	LO-FI	0B	0			○	○		○
	L-F	NOISY	0B	10			○	○		
	L-F	DIGITAL TURNTABLE	0B	20			○	○		
TECH										
	TEC	RING MODULATOR	0C	0			○	○		○
	TEC	DYNAMIC RING MODULATOR	0C	10			○	○		
	TEC	DYNAMIC FILTER	0C	20			○	○		○
	TEC	AUTO SYNTH	0C	30			○	○		
	TEC	ISOLATOR	0C	40			○	○		○
	TEC	SLICE	0C	50			○	○		○
	TEC	TECH MODULATION	0C	60			○	○		
MISC										
	MSC	VCM EQ 501	0D	0			○	○		
	MSC	HARMONIC ENHANCER	0D	10			○	○		
	MSC	TALKING MODULATOR	0D	20			○	○		
	MSC	DAMPER RESONANCE	0D	30			○	○		
	MSC	PITCH CHANGE	0D	40			○	○		
	MSC	EARLY REFLECTION	0D	50		○	○	○		
	MSC	VOCODER	0D	60					○	
	MSC	NOISE GATE+COMP+EQ	0D	70			○	○		

Effect Parameter List

Reverb Block

[0] NO EFFECT

When this type is selected, no parameters are available.

[1] REV-X HALL [4] REV-X ROOM

No.	Parameter	Range	Value	Table No.
1	Reverb Time	0.3s – 18.0s (HALL)/ 10.0s (ROOM)	(0 – 69)	23/24
2	Diffusion	0 – 10	(0 – 10)	
3	Initial Delay	0.1ms – 200.0ms	(0 – 127)	5
4	HPF Cutoff Frequency	20Hz – 8.0kHz	(0 – 52)	3
5	LPF Cutoff Frequency	1.0kHz – 20.0kHz	(34 – 60)	3
6	Room Size	0 – 31	(0 – 31)	
7	High Ratio	0.1 – 1.0	(1 – 10)	
8	Low Ratio	0.1 – 1.4	(1 – 14)	
9	Decay	0 – 63	(0 – 63)	
10	—			
11	—			
12	—			
13	—			
14	—			
15	—			
16	—			

REV-X HALL: (Table No.23)

REV-X ROOM: (Table No.24)

For details, refer to the Effect Data Assign Table.

[2] R3 HALL [3] SPX HALL [5] R3 ROOM [6] SPX ROOM [7] R3 PLATE [8] SPX STAGE

No.	Parameter	Range	Value	Table No.
1	Reverb Time	0.3s – 30.0s	(0 – 69)	4
2	Diffusion	0 – 10	(0 – 10)	
3	Initial Delay	0.1ms – 200.0ms	(0 – 127)	5
4	HPF Cutoff Frequency	20Hz – 8.0kHz	(0 – 52)	3
5	LPF Cutoff Frequency	1.0kHz – 20.0kHz	(34 – 60)	3
6	—			
7	—			
8	—			
9	—			
10	—			
11	Reverb Delay	0.1ms – 200.0ms	(0 – 127)	5
12	Density	0 – 4	(0 – 4)	
13	ER/Rev Balance	E63>R – E=R – E<R63	(1 – 127)	
14	Feedback High Damp	0.1 – 1.0	(1 – 10)	
15	Feedback Level	-63 – +63	(1 – 127)	
16	—			

[9] SPACE SIMULATOR

No.	Parameter	Range	Value	Table No.
1	Reverb Time	0.3s – 30.0s	(0 – 69)	4
2	Diffusion	0 – 10	(0 – 10)	
3	Initial Delay	0.1ms – 200.0ms	(0 – 127)	5
4	HPF Cutoff Frequency	20Hz – 8.0kHz	(0 – 52)	3
5	LPF Cutoff Frequency	1.0kHz – 20.0kHz	(34 – 60)	3
6	Width	0.5m – 30.2m	(0 – 104)	11
7	Height	0.5m – 30.2m	(0 – 104)	11
8	Depth	0.5m – 30.2m	(0 – 104)	11
9	Wall Vary	0 – 30	(0 – 30)	
10	—			
11	Reverb Delay	0.1ms – 200.0ms	(0 – 127)	5
12	Density	0 – 4	(0 – 4)	
13	ER/Rev Balance	E63>R – E=R – E<R63	(1 – 127)	
14	Feedback High Damp	0.1 – 1.0	(1 – 10)	
15	Feedback Level	-63 – +63	(1 – 127)	
16	Space Type	0 – 1	(0 – 1)	

Chorus, Insertion Block

[0] THRU/NO EFFECT

When this type is selected, no parameters are available.

Category — REVERB

[1] SPX HALL [2] SPX ROOM [3] SPX STAGE

No.	Parameter	Range	Value	Table No.
1	Reverb Time	0.3s – 30.0s	(0 – 69)	4
2	Diffusion	0 – 10	(0 – 10)	
3	Initial Delay	0.1ms – 99.3ms	(0 – 63)	5
4	HPF Cutoff Frequency	20Hz – 8.0kHz	(0 – 52)	3
5	LPF Cutoff Frequency	1.0kHz – 20.0kHz	(34 – 60)	3
6	—			
7	—			
8	—			
9	—			
10	Dry/Wet Balance	D63>W – D=W – D<W63	(1 – 127)	
11	Reverb Delay	0.1ms – 99.3ms	(0 – 63)	5
12	Density	0 – 4	(0 – 4)	
13	ER/Rev Balance	E63>R – E=R – E<R63	(1 – 127)	
14	Feedback High Damp	0.1 – 1.0	(1 – 10)	
15	Feedback Level	-63 – +63	(1 – 127)	
16	—			

Category — DELAY

[1] CROSS DELAY

No.	Parameter	Range	Value	Table No.
1	Delay Time L>R	0.1ms – 1638.3ms	(1 – 16383)	
2	Delay Time R>L	0.1ms – 1638.3ms	(1 – 16383)	
3	Feedback Level	-63 – +63	(1 – 127)	
4	Input Select	L, R, L&R	(0 – 2)	
5	Feedback High Damp	0.1 – 1.0	(1 – 10)	
6	—			
7	—			
8	—			
9	—			
10	Dry/Wet Balance	D63>W – D=W – D<W63	(1 – 127)	
11	—			
12	—			
13	EQ Low Frequency	32Hz – 2.0kHz	(4 – 40)	3
14	EQ Low Gain	-12dB – +12dB	(52 – 76)	
15	EQ High Frequency	500Hz – 16.0kHz	(28 – 58)	3
16	EQ High Gain	-12dB – +12dB	(52 – 76)	

[2] TEMPO CROSS DELAY

No.	Parameter	Range	Value	Table No.
1	Delay Time L>R	32nd/3 – 4thx6	(0 – 19)	13
2	Delay Time R>L	32nd/3 – 4thx6	(0 – 19)	13
3	Feedback Level	-63 – +63	(1 – 127)	
4	Input Select	L, R, L&R	(0 – 2)	
5	Feedback High Damp	0.1 – 1.0	(1 – 10)	
6	Lag	-63ms – +63ms	(1 – 127)	
7	—			
8	—			
9	—			
10	Dry/Wet Balance	D63>W – D=W – D<W63	(1 – 127)	
11	—			
12	—			

13 – 16: Same as the parameters shaded in gray in CROSS DELAY above.

[3] TEMPO DELAY MONO

No.	Parameter	Range	Value	Table No.
1	Delay Time	32nd/3 – 4thx6	(0 – 19)	13
2	Feedback Level	-63 – +63	(1 – 127)	
3	Feedback High Damp	0.1 – 1.0	(1 – 10)	
4	L/R Diffusion	-63ms – +63ms	(1 – 127)	
5	Lag	-63ms – +63ms	(1 – 127)	
6	—			
7	—			
8	—			
9	—			
10	Dry/Wet Balance	D63>W – D=W – D<W63	(1 – 127)	
11	—			
12	—			

13 – 16: Same as the parameters shaded in gray in CROSS DELAY above.

[4] TEMPO DELAY STEREO

No.	Parameter	Range	Value	Table No.
1	Delay Time	32nd/3 – 4thx6	(0 – 19)	13
2	Feedback Level	-63 – +63	(1 – 127)	
3	Feedback High Dump	0.1 – 1.0	(1 – 10)	
4	L/R Diffusion	-63ms – +63ms	(1 – 127)	
5	Lag	-63ms – +63ms	(1 – 127)	
6	—			
7	—			
8	—			
9	—			
10	Dry/Wet Balance	D63>W – D=W – D<W63	(1 – 127)	
11	—			
12	—			

13 – 16: Same as the parameters shaded in gray in CROSS DELAY on page 98.

[5] CONTROL DELAY

No.	Parameter	Range	Value	Table No.
1	Delay Time	0.1ms – 1486.0ms	(1 – 14860)	
2	Delay transition rate	1 – 48	(1 – 48)	
3	Feedback Level	-63 – +63	(1 – 127)	
4	Feedback High Dump	0.1 – 1.0	(1 – 10)	
5	—			
6 – 9: Same as the parameters shaded in gray in CROSS DELAY on page 98.				
10	Dry/Wet Balance	D63>W – D=W – D<W63	(1 – 127)	
11	Control Type	Normal, Scratch	(0 – 1)	
12	—			
13	—			
14	—			
15	—			
16	—			

[6] DELAY L, R

No.	Parameter	Range	Value	Table No.
1	Delay Time L	0.1ms – 1638.3ms	(1 – 16383)	
2	Delay Time R	0.1ms – 1638.3ms	(1 – 16383)	
3	Feedback Time 1	0.1ms – 1638.3ms	(1 – 16383)	
4	Feedback Time 2	0.1ms – 1638.3ms	(1 – 16383)	
5	Feedback Level	-63 – +63	(1 – 127)	
6	Feedback High Dump	0.1 – 1.0	(1 – 10)	
7	—			
8	—			
9	—			
10	Dry/Wet Balance	D63>W – D=W – D<W63	(1 – 127)	
11	—			
12	—			

13 – 16: Same as the parameters shaded in gray in CROSS DELAY on page 98.

[7] DELAY L, C, R

No.	Parameter	Range	Value	Table No.
1	Delay Time L	0.1ms_1638.3ms	(1 – 16383)	
2	Delay Time R	0.1ms_1638.3ms	(1 – 16383)	
3	Delay Time C	0.1ms_1638.3ms	(1 – 16383)	
4	Feedback Time	0.1ms_1638.3ms	(1 – 16383)	
5	Feedback Level	-63 – +63	(1 – 127)	
6	Delay Level C	0 – 127	(0 – 127)	
7	Feedback High Dump	0.1 – 1.0	(1 – 10)	
8	—			
9	—			
10	Dry/Wet Balance	D63>W – D=W – D<W63	(1 – 127)	
11	—			
12	—			

13 – 16: Same as the parameters shaded in gray in CROSS DELAY on page 98.

[8] DELAY L, R (STEREO)

No.	Parameter	Range	Value	Table No.
1	Delay Time L	0.1ms – 1638.3ms	(1 – 16383)	
2	Delay Time R	0.1ms – 1638.3ms	(1 – 16383)	
3	Feedback Time L	0.1ms – 1638.3ms	(1 – 16383)	
4	Feedback Time R	0.1ms – 1638.3ms	(1 – 16383)	
5	Feedback Level	-63 – +63	(1 – 127)	
6	Feedback High Dump	0.1 – 1.0	(1 – 10)	
7	—			
8	—			
9	—			
10	Dry/Wet Balance	D63>W – D=W – D<W63	(1 – 127)	
11	—			
15	—			

13 – 16: Same as the parameters shaded in gray in CROSS DELAY on page 98.

Category — CHORUS

[1] G CHORUS

No.	Parameter	Range	Value	Table No.
1	LFO Speed	0.0Hz – 39.70Hz	(0 – 127)	1
2	—			
3	PM Depth	0 – 127	(0 – 127)	
4	Feedback Level	-63 – +63	(1 – 127)	
5	Delay Offset	0.0ms – 50.0ms	(0 – 127)	2
6 – 9: Same as the parameters shaded in gray in CROSS DELAY on page 98.				
10	Dry / Wet Balance	D63>W – D=W – D<W63	(1 – 127)	
11	EQ Mid Frequency	100Hz – 10.0kHz	(14 – 54)	3
12	EQ Mid Gain	-12dB – +12dB	(52 – 76)	
13	EQ Mid Width	0.1 – 12.0	(1 – 120)	
14	—			
15	Input Mode	Mono, Stereo	(0 – 1)	
16	—			

[2] 2 MODULATOR

No.	Parameter	Range	Value	Table No.
1	LFO Speed	0.0Hz – 39.70Hz	(0 – 127)	1
2	AM Depth	0 – 127	(0 – 127)	
3	PM Depth	0 – 127	(0 – 127)	
4	Feedback Level	-63 – +63	(1 – 127)	
5	Delay Offset	0.0ms – 50.0ms	(0 – 127)	2
6 – 9: Same as the parameters shaded in gray in CROSS DELAY on page 98.				
10	Dry / Wet Balance	D63>W – D=W – D<W63	(1 – 127)	
11	EQ Mid Frequency	100Hz – 10.0kHz	(14 – 54)	3
12	EQ Mid Gain	-12dB – +12dB	(52 – 76)	
13	EQ Mid Width	0.1 – 12.0	(1 – 120)	
14	—			
15	Input Mode	Mono, Stereo	(0 – 1)	
16	—			

[3] SPX CHORUS

No.	Parameter	Range	Value	Table No.
1	LFO Speed	0.0Hz – 39.70Hz	(0 – 127)	1
2	LFO Depth	0 – 127	(0 – 127)	
3	Feedback Level	-63 – +63	(1 – 127)	
4	Delay Offset	0.0ms – 50.0ms	(0 – 127)	2
5	—			
6 – 9: Same as the parameters shaded in gray in CROSS DELAY on page 98.				
10	Dry/Wet Balance	D63>W – D=W – D<W63	(1 – 127)	
11	EQ Mid Frequency	100Hz – 10.0kHz	(14 – 54)	3
12	EQ Mid Gain	-12dB – +12dB	(52 – 76)	
13	EQ Mid Width	0.1 – 12.0	(1 – 120)	
14	—			
15	Input Mode	Mono, Stereo	(0 – 1)	
16	—			

[4] SYMPHONIC

No.	Parameter	Range	Value	Table No.
1	LFO Speed	0.0Hz – 39.70Hz	(0 – 127)	1
2	LFO Depth	0 – 127	(0 – 127)	
3	Delay Offset	0.0ms – 50.0ms	(0 – 127)	2
4	—			
5	—			
6 – 9: Same as the parameters shaded in gray in CROSS DELAY on page 98.				
10	Dry/Wet Balance	D63>W – D=W – D<W63	(1 – 127)	
11	EQ Mid Frequency	100Hz – 10.0kHz	(14 – 54)	3
12	EQ Mid Gain	-12dB – +12dB	(52 – 76)	
13	EQ Mid Width	0.1 – 12.0	(1 – 120)	
14	—			
15	—			
16	—			

[5] ENSEMBLE DETUNE

No.	Parameter	Range	Value	Table No.
1	Detune	-50cent – +50cent	(14 – 114)	
2	Initial Delay Lch	0.0ms – 50.0ms	(0 – 127)	2
3	Initial Delay Rch	0.0ms – 50.0ms	(0 – 127)	2
4	Spread	0 – 63	(0 – 63)	
5	—			
6	—			
7	—			
8	—			
9	—			
10	Dry/Wet Balance	D63>W – D=W – D<W63	(1 – 127)	
11 – 14: Same as the parameters shaded in gray in CROSS DELAY on page 98.				
15	—			
16	—			

Category — FLANGER

[1] VCM FLANGER

No.	Parameter	Range	Value	Table No.
1	Speed	0.040Hz – 10.00Hz	(0 – 235)	20
2	Manual	0 – 127	(0 – 127)	
3	Depth	0 – 127	(0 – 127)	
4	Feedback	0 – 127	(0 – 127)	
5	Type	1 – 3	(0 – 2)	
6	Spread	0 – 127	(0 – 127)	
7	Mix	0 – 127	(0 – 127)	
8	—			
9	—			
10	—			
11	—			
12	—			
13	—			
14	—			
15	—			
16	—			

[2] CLASSIC FLANGER

No.	Parameter	Range	Value	Table No.
1	LFO Speed	0.0Hz – 39.70Hz	(0 – 127)	1
2	LFO Depth	0 – 127	(0 – 127)	
3	LFO Wave	Triangle, Sine, Random	(0 – 2)	
4	Delay Offset	0.09 – 36.21ms	(0 – 139)	18
5	Feedback Level	-100 – +100%	(0 – 200)	
6 – 9: Same as the parameters shaded in gray in CROSS DELAY on page 98.				
10	Dry/Wet Balance	D63>W – D=W – D<W63	(1 – 127)	
11	EQ Mid Frequency	100Hz – 10.0kHz	(14 – 54)	3
12	EQ Mid Gain	-12dB – +12dB	(52 – 76)	
13	EQ Mid Width	0.1 – 12.0	(1 – 120)	
14	Modulation Phase	-180 – +180	(0 – 16)	19
15	Feedback High Damp	0.1 – 1.0	(1 – 10)	
16	Analog Feel	0 – 10	(0 – 10)	

[3] TEMPO FLANGER

No.	Parameter	Range	Value	Table No.
1	LFO Speed	16th – 4thx16	(5 – 29)	13
2	LFO Depth	0 – 127	(0 – 127)	
3	Feedback Level	-63 – +63	(1 – 127)	
4	Delay Offset	0.0ms – 50.0ms	(0 – 127)	2
5	LFO Phase Reset	Off (free run), Key On Reset, SEQ Start Reset	(0 – 2)	
6 – 9: Same as the parameters shaded in gray in CROSS DELAY on page 98.				
10	Dry/Wet Balance	D63>W – D=W – D<W63	(1 – 127)	
11	EQ Mid Frequency	100Hz – 10.0kHz	(14 – 54)	3
12	EQ Mid Gain	-12dB – +12dB	(52 – 76)	
13	EQ Mid Width	0.1 – 12.0	(1 – 120)	
14	LFO Phase Difference	-180deg – +180deg	(4 – 124)	
15	—			
16	—			

[4] DYNAMIC FLANGER

No.	Parameter	Range	Value	Table No.
1	Sensitivity	0 – 127	(0 – 127)	
2	Delay Offset	0 – 127	(0 – 127)	
3	Feedback Level	-63 – +63	(1 – 127)	
4	Attack Time	0.3ms – 227ms	(0 – 127)	15
5	Release Time	2.6ms – 2171ms	(0 – 127)	16
6	Release Curve	0 – 127	(0 – 127)	
7	Direction	Up, Down	(0 – 1)	
8	Dyna Threshold Level	0 – 127	(0 – 127)	
9	Dyna Level Offset	0 – 127	(0 – 127)	
10	Dry/Wet Balance	D63>W – D=W – D<W63	(1 – 127)	
11	—			
12	—			
13 – 16: Same as the parameters shaded in gray in CROSS DELAY on page 98.				

Category — PHASER

[1] VCM PHASER MONO

No.	Parameter	Range	Value	Table No.
1	Speed	0.100Hz – 10.00Hz	(0 – 252)	21
2	Manual	0 – 127	(0 – 127)	
3	Depth	0 – 127	(0 – 127)	
4	Feedback	0 – 127	(0 – 127)	
5	Stage	4, 6, 8, 10, 12, 16	(0 – 5)	
6	Mode	1, 2, 3	(0 – 2)	
7	Color	0 – 127	(0 – 127)	
8	—			
9	—			
10	—			
11	—			
12	—			
13	—			
14	—			
15	—			
16	—			

The Color parameter is not available in the following conditions: When Mode is set to 1 and Stage is set to 4, 6, 8, 12 or 16; or when Mode is set to 2 and Stage is set to 4 or 10.

[2] VCM PHASER STEREO

No.	Parameter	Range	Value	Table No.
1	Speed	0.100Hz – 10.00Hz	(0 – 252)	21
2	Manual	0 – 127	(0 – 127)	
3	Depth	0 – 127	(0 – 127)	
4	Feedback	0 – 127	(0 – 127)	
5	Stage	4, 6, 8, 10	(0 – 3)	
6	Mode	1, 2	(0 – 1)	
7	Color	0 – 127	(0 – 127)	
8	Spread	0 – 127	(0 – 127)	
9	—			
10	—			
11	—			
12	—			
13	—			
14	—			
15	—			
16	—			

The Color parameter is not available in the following conditions: When Mode is set to 1 and Stage is set to 4, 6, or 8; or when Mode is set to 2 and Stage is set to 4 or 10.

[3] TEMPO PHASER

No.	Parameter	Range	Value	Table No.
1	LFO Speed	16th – 4thx16	(5 – 29)	13
2	LFO Depth	0 – 127	(0 – 127)	
3	Phase Shift Offset	0 – 127	(0 – 127)	
4	Feedback Level	-63 – +63	(1 – 127)	
5	LFO Phase Reset	Off (free run), Key On Reset, SEQ Start Reset	(0 – 2)	
6 – 9: Same as the parameters shaded in gray in CROSS DELAY on page 98.				
10	Dry/Wet Balance	D63>W – D=W – D<W63	(1 – 127)	
11	Stage	4 – 22	(4 – 22)	
12	Diffusion	Mono, Stereo	(0 – 1)	
13	—			
14	—			
15	—			
16	—			

[4] DYNAMIC PHASER

No.	Parameter	Range	Value	Table No.
1	Sensitivity	0 – 127	(0 – 127)	
2	Dyna Level Offset	0 – 127	(0 – 127)	
3	Feedback Level	-63 – +63	(1 – 127)	
4	Attack Time	0.3ms – 227ms	(0 – 127)	15
5	Release Time	2.6ms – 2171ms	(0 – 127)	16
6	Release Curve	0 – 127	(0 – 127)	
7	Direction	Up, Down	(0 – 1)	
8	Dyna Threshold Level	0 – 127	(0 – 127)	
9	—			
10	Dry/Wet Balance	D63>W – D=W – D<W63	(1 – 127)	
11	Stage	4, 5, 6	(4 – 6)	
12	—			
13 – 16: Same as the parameters shaded in gray in CROSS DELAY on page 98.				

Category — TREMOLO&ROTARY

[1] AUTO PAN

No.	Parameter	Range	Value	Table No.
1	LFO Speed	0.0Hz – 39.70Hz	(0 – 127)	1
2	L/R Depth	0 – 127	(0 – 127)	
3	F/R Depth	0 – 127	(0 – 127)	
4	PAN Direction	L<>R, L>>R, L<<R, Lturn, Rturn, L/R	(0 – 5)	
5	LFO Wave	0 – 28	(0 – 28)	
6 – 9: Same as the parameters shaded in gray in CROSS DELAY on page 98.				
10	—			
11	EQ Mid Frequency	100Hz – 10.0kHz	(14 – 54)	3
12	EQ Mid Gain	-12dB – +12dB	(52 – 76)	
13	EQ Mid Width	0.1 – 12.0	(1 – 120)	
14	—			
15	Input Mode	Mono, Stereo	(0 – 1)	
16	—			

[2] TREMOLO

No.	Parameter	Range	Value	Table No.
1	LFO Speed	0.0Hz – 39.70Hz	(0 – 127)	1
2	AM Depth	0 – 127	(0 – 127)	
3	PM Depth	0 – 127	(0 – 127)	
4	—			
5	—			
6 – 9: Same as the parameters shaded in gray in CROSS DELAY on page 98.				
10	—			
11	EQ Mid Frequency	100Hz – 10.0kHz	(14 – 54)	3
12	EQ Mid Gain	-12dB – +12dB	(52 – 76)	
13	EQ Mid Width	0.1 – 12.0	(1 – 120)	
14	LFO Phase difference	-180deg – +180deg	(4 – 124)	
15	Input Mode	Mono, Stereo	(0 – 1)	
16	—			

[3] ROTARY SPEAKER

No.	Parameter	Range	Value	Table No.
1	Rotor Speed Slow	0.0Hz – 2.65Hz	(0 – 63)	1
2	Horn Speed Slow	0.0Hz – 2.65Hz	(0 – 63)	1
3	Rotor Speed Fast	0.0Hz – 39.70Hz	(64 – 127)	1
4	Horn Speed Fast	0.0Hz – 39.70Hz	(64 – 127)	1
5	Slow-Fast Time of Rotor	0 – 127	(0 – 127)	
6	Slow-Fast Time of Horn	0 – 127	(0 – 127)	
7	Drive Rotor	0 – 127	(0 – 127)	
8	Drive Horn	0 – 127	(0 – 127)	
9	Rotor/Horn Balance	R63>H – R=H – R<H63	(1 – 127)	
10	—			
11 – 14: Same as the parameters shaded in gray in CROSS DELAY on page 98.				
15	Mic L-R Angle	0deg – 180deg	(0 – 60)	
16	Speed Control	Slow, Fast	(0 – 1)	

Category — DISTORTION

[1] AMP SIMULATOR 1

No.	Parameter	Range	Value	Table No.
1	Overdrive	0 – 100%	(0 – 100)	
2	Device	Transistor, Vintage Tube, Distortion 1, Distortion 2, Fuzz	(0 – 4)	
3	Speaker Type	Flat, Stack, Combo, Twin, Radio, Megaphone	(0 – 5)	
4	Presence	-10 – 10	(0 – 20)	
5	Output Level	0 – 100%	(0 – 100)	
6	—			
7	—			
8	—			
9	—			
10	Dry/Wet Balance	D63>W _ D=W _ D<W63	(1 – 127)	
11	—			
12	—			
13	—			
14	—			
15	—			
16	—			

[2] AMP SIMULATOR 2

No.	Parameter	Range	Value	Table No.
1	Overdrive	0 – 127	(0 – 127)	
2	AMP Type	Off, Stack, Combo, Tube, Crunch, Hi Gain, British	(0 – 6)	
3	LPF Cutoff Frequency	1.0kHz – 20.0kHz	(34 – 60)	3
4	Output Level	0 – 127	(0 – 127)	
5	—			
6	—			
7	—			
8	—			
9	—			
10	Dry/Wet Balance	D63>W – D=W – D<W63	(1 – 127)	
11	—			
12	—			
13	—			
14	—			
15	—			
16	—			

[3] COMP DISTORTION

No.	Parameter	Range	Value	Table No.
1	Overdrive	0 – 127	(0 – 127)	
2	EQ Low Frequency	32Hz – 2.0kHz	(4 – 40)	3
3	EQ Low Gain	-12dB – +12dB	(52 – 76)	
4	LPF Cutoff Frequency	1.0kHz – 20.0kHz	(34 – 60)	3
5	Output Level	0 – 127	(0 – 127)	
6	—			
7	EQ Mid Frequency	100Hz – 10.0kHz	(14 – 54)	3
8	EQ Mid Gain	-12dB – +12dB	(52 – 76)	
9	EQ Mid Width	0.1 – 12.0	(1 – 120)	
10	Dry / Wet Balance	D63>W – D=W – D<W63	(1 – 127)	
11	Edge	0 – 127	(0 – 127)	
12	Attack	1ms – 40ms	(0 – 19)	8
13	Release	10ms – 680ms	(0 – 15)	9
14	Threshold	-48dB – -6dB	(79 – 121)	
15	Ratio	1 – 20.0	(0 – 7)	10
16	—			

[3] COMP DISTORTION DELAY

No.	Parameter	Range	Value	Table No.
1	Overdrive	0 – 100%	(0 – 100)	
2	Device	Transistor, Vintage Tube, Distortion 1, Distortion 2, Fuzz	(0 – 4)	
3	Speaker Type	Flat, Stack, Combo, Twin, Radio, Megaphone	(0 – 5)	
4	Presence	-10 – 10	(0 – 20)	
5	Output Level	0 – 100%	(0 – 100)	
6	Delay Time L	0.1ms – 1638.3ms	(1 – 16383)	
7	Delay Time R	0.1ms – 1638.3ms	(1 – 16383)	
8	Feedback Time	0.1ms – 1638.3ms	(1 – 16383)	
9	Feedback Level	-63 – +63	(1 – 127)	
10	Dry/Wet Balance	D63>W – D=W – D<W63	(1 – 127)	
11	Delay Mix	0 – 127	(0 – 127)	
12	Feedback High Damp	0.1 – 1.0	(1 – 10)	
13	Compress	-48dB – -6dB	(79 – 121)	
14	—			
15	—			
16	—			

Category — COMPRESSOR

[1] VCM COMPRESSOR 376

No.	Parameter	Range	Value	Table No.
1	Input Level	-∞ – 0.00dB	(0 – 200)	25
2	Output Level	-∞ – 0.00dB	(0 – 200)	25
3	Ratio	2, 4, 8, 12, 20	(0 – 4)	
4	Attack	0.022ms – 50.40ms	(0 – 200)	26
5	Release	10.88ms – 544.22ms	(0 – 200)	27
6	Meter	OUT, GR	(0 – 1)	
7	—			
8	—			
9	—			
10	—			
11	—			
12	—			
13	—			
14	—			
15	—			
16	—			

[2] CLASSIC COMPRESSOR

No.	Parameter	Range	Value	Table No.
1	Attack	1ms – 40ms	(0 – 19)	8
2	Release	10ms – 680ms	(0 – 15)	9
3	Threshold	-48dB – -6dB	(79 – 121)	
4	Ratio	1 – 20.0	(0 – 7)	10
5	Output Level	0 – 127	(0 – 127)	
6	—			
7	—			
8	—			
9	—			
10	—			
11	—			
12	—			
13	—			
14	—			
15	—			
16	—			

[3] MULTI BAND COMP

No.	Parameter	Range	Value	Table No.
1	Low Attack	1ms – 200ms	(0 – 29)	8
2	Low Threshold	-54dB – -6dB	(73 – 121)	
3	Low Ratio	1 – 20.0	(0 – 7)	10
4	Low Gain	-∞ – +18dB	(0 – 55)	14
5	Mid Attack	1ms – 200ms	(0 – 29)	8
6	Mid Threshold	-54dB – -6dB	(73 – 121)	
7	Mid Ratio	1 – 20.0	(0 – 7)	10
8	Mid Gain	-∞ – +18dB	(0 – 55)	14
9	High Attack	1ms – 200ms	(0 – 29)	8
10	High Threshold	-54dB – -6dB	(73 – 121)	
11	High Ratio	1 – 20.0	(0 – 7)	10
12	High Gain	-∞ – +18dB	(0 – 55)	14
13	Divide Freq Low	16Hz – 20kHz	(0 – 124)	28
14	Divide Freq High	16Hz – 20kHz	(0 – 124)	28
15	Common Release	10msec – 3000msec	(0 – 23)	9
16	—			

Category — WAH

[1] VCM AUTO WAH

No.	Parameter	Range	Value	Table No.
1	Speed	0.100Hz – 20.00Hz	(0 – 254)	22
2	Bottom	0 – 127	(0 – 127)	
3	Top	0 – 127	(0 – 127)	
4	Resonance Offset	-12.0 – +12.0	(40 – 88)	
5	LFO Wave	Sin, Trp	(0 – 1)	
6	Type	High, Mid, Low, Bass	(0 – 3)	
7	Overdrive	0.0dB – +40.0dB	(0 – 80)	
8	Output	-20.0dB – +10.0dB	(24 – 84)	
9	—			
10	—			
11	—			
12	—			
13	—			
14	—			
15	—			
16	—			

When the value of Bottom is greater than Top, the sound will not be modulated and only the Bottom value is available.

[2] VCM TOUCH WAH

No.	Parameter	Range	Value	Table No.
1	Sensitivity	0 – 127	(0 – 127)	
2	Bottom	0 – 127	(0 – 127)	
3	Top	0 – 127	(0 – 127)	
4	Resonance Offset	-12.0 – +12.0	(40 – 88)	
5	Direction	Up, Down	(0 – 1)	
6	Type	High, Mid, Low, Bass	(0 – 3)	
7	Overdrive	0.0dB – +40.0dB	(0 – 80)	
8	Output	-20.0dB – +10.0dB	(24 – 84)	
9	—			
10	—			
11	Attack Offset	-5 – +5	(59 – 69)	
12	—			
13	—			
14	—			
15	—			
16	—			

When the value of Bottom is greater than Top, the sound will not be modulated and only the Bottom value is available.

[3] VCM PEDAL WAH

No.	Parameter	Range	Value	Table No.
1	Pedal Control	0 – 127	(0 – 127)	
2	Bottom	0 – 127	(0 – 127)	
3	Top	0 – 127	(0 – 127)	
4	Resonance Offset	-12.0 – +12.0	(40 – 88)	
5	Direction	Up, Down	(0 – 1)	
6	Type	High, Mid, Low, Bass	(0 – 3)	
7	Overdrive	0.0dB – +40.0dB	(0 – 80)	
8	Output	-20.0dB – +10.0dB	(24 – 84)	
9	—			
10	—			
11	—			
12	—			
13	—			
14	—			
15	—			
16	—			

When the value of Bottom is greater than Top, the sound will not be modulated and only the Bottom value is available.

Category — Lo-Fi

[1] LO-FI

No.	Parameter	Range	Value	Table No.
1	Sampling Freq. Control	44.1 – 344Hz	(0 – 127)	12
2	Word Length	1 – 127	(1 – 127)	
3	Output Gain	-6dB – +36dB	(0 – 42)	
4	Pre-LPF Cutoff Frequency	63Hz – 20.0kHz	(10 – 60)	3
5	Filter Type	Thru, Power Bass, Radio, Telephone, Clean, Low	(0 – 5)	
6	Pre-LPF Resonance	1 – 12.0	(10 – 120)	
7	Bit Assign	0 – 6	(0 – 6)	
8	Emphasis	Off/On	(0 – 1)	
9	—			
10	Dry/Wet Balance	D63>W – D=W – D<W63	(1 – 127)	
11	—			
12	—			
13	—			
14	—			
15	Input Mode	Mono, Stereo	(0 – 1)	
16	—			

[2] NOISY

No.	Parameter	Range	Value	Table No.
1	Mod Depth	0 – 10	(0 – 10)	
2	Mod Speed	0 – 127	(0 – 127)	
3	Mod Feedback	-63 – +63	(1 – 127)	
4	Mod Mix Balance	1 – 127	(1 – 127)	
5	Drive	0 – 127	(0 – 127)	
6	AM Speed	0.00Hz – 39.7Hz	(0 – 127)	1
7	AM Depth	0 – 127	(0 – 127)	
8	LPF Cutoff Frequency	1.0kHz – 20.0kHz	(34 – 60)	3
9	LPF Resonance	1.0 – 12.0	(10 – 120)	
10	Dry/Wet Balance	D63>W – D=W – D<W63	(1 – 127)	
11	EQ Frequency	100Hz – 10.0kHz	(14 – 54)	3
12	EQ Gain	-12 – +12dB	(52 – 76)	
13	EQ Width	1.0 – 12.0	(10 – 120)	
14	—			
15	—			
16	—			

[3] DIGITAL TURNTABLE

No.	Parameter	Range	Value	Table No.
1	Click Density	0 – 5	(0 – 5)	
2	Click Level	0 – 127	(0 – 127)	
3	Noise Tone	0 – 6	(0 – 6)	
4	Noise Mod Speed	0.00Hz – 39.7Hz	(0 – 127)	1
5	Noise Mod Depth	0 – 127	(0 – 127)	
6	Dry Send to Noise	0 – 127	(0 – 127)	
7	Noise LPF Cutoff Frequency	1.0kHz – 20.0kHz	(34 – 60)	3
8	Noise LPF Q	1.0 – 12.0	(10 – 120)	
9	Noise Level	0 – 127	(0 – 127)	
10	—			
11	Dry Level	0 – 127	(0 – 127)	
12	Dry LPF Cutoff Frequency	1.0kHz – 20.0kHz	(34 – 60)	3
13	—			
14	—			
15	—			
16	—			

Category — TEC

[1] RING MODULATOR

No.	Parameter	Range	Value	Table No.
1	OSC Frequency Coarse	0.5 – 5kHz	(0 – 127)	17
2	OSC Frequency Fine	0 – 127	(0 – 127)	
3	LFO Wave	Tri, Sine	(0 – 1)	
4	LFO Depth	0 – 127	(0 – 127)	
5	LFO Speed	0.0Hz – 39.70Hz	(0 – 127)	1
6	HPF Cutoff Frequency	20Hz – 8.0kHz	(0 – 52)	3
7	LPF Cutoff Frequency	1.0kHz – 20.0kHz	(34 – 60)	3
8	—			
9	—			
10	Dry/Wet Balance	D63>W – D=W – D<W63	(1 – 127)	
11	—			
12	—			

13 – 16: Same as the parameters shaded in gray in CROSS DELAY on page 98.

[2] DYNAMIC RING MODULATOR

No.	Parameter	Range	Value	Table No.
1	Sensitivity	0 – 127	(0 – 127)	
2	HPF Cutoff Frequency	20Hz – 8.0kHz	(0 – 52)	3
3	LPF Cutoff Frequency	1.0kHz – 20.0kHz	(34 – 60)	3
4	Attack Time	0.3ms – 227ms	(0 – 127)	15
5	Release Time	2.6ms – 2171ms	(0 – 127)	16
6	Release Curve	0 – 127	(0 – 127)	
7	Direction	Up, Down	(0 – 1)	
8	Dyna Threshold Level	0 – 127	(0 – 127)	
9	Dyna Level Offset	0 – 127	(0 – 127)	
10	Dry/Wet Balance	D63>W – D=W – D<W63	(1 – 127)	
11	—			
12	—			

13 – 16: Same as the parameters shaded in gray in CROSS DELAY on page 98.

[3] DYNAMIC FILTER

No.	Parameter	Range	Value	Table No.
1	Filter Type	LPF (12dB), LPF (18dB), LPF (24dB), HPF, BPF, BEF	(0 – 5)	
2	Sensitivity	0 – 127	(0 – 127)	
3	Dyna Level Offset	0 – 127	(0 – 127)	
4	Resonance	-16 – +111	(0 – 127)	
5	Attack Time	0.3ms – 227ms	(0 – 127)	15
6	Release Time	2.6ms – 2171ms	(0 – 127)	16
7	Release Curve	0 – 127	(0 – 127)	
8	Direction	Up, Down	(0 – 1)	
9	Dyna Threshold Level	0 – 127	(0 – 127)	
10	Dry/Wet Balance	D63>W – D=W – D<W63	(1 – 127)	
11	—			
12	—			

13 – 16: Same as the parameters shaded in gray in CROSS DELAY on page 98.

[4] AUTO SYNTH

No.	Parameter	Range	Value	Table No.
1	Mod Speed	0 – 127	(0 – 127)	
2	Mod Wave Type	Type A, Type B, Type C, Type D	(0 – 3)	
3	Mod Depth	0 – 127	(0 – 127)	
4	Mod Depth Ofst R	-63 – +63	(1 – 127)	
5	HPF Cutoff Frequency	20Hz – 8.0kHz	(0 – 52)	3
6	LPF Cutoff Frequency	1.0kHz – 20.0kHz	(34 – 60)	3
7	Delay Time	0.1 – 370.0ms	(1 – 3700)	
8	Delay Time Ofst R	0 – 884	(0 – 884)	
9	Delay Level	0 – 127	(0 – 127)	
10	Dry Mix Level	0 – 127	(0 – 127)	
11	Feedback Level	-63 – +63	(1 – 127)	
12	FB Level Ofst R	-63 – +63	(1 – 127)	
13	AM Speed	0.00Hz – 39.7Hz	(0 – 127)	1
14	AM Wave	Tri, Sine, Saw Up, Saw Down	(0 – 3)	
15	AM Depth	0 – 127	(0 – 127)	
16	AM Inverse R	Normal, Inverse	(0 – 1)	

[5] ISOLATOR

No.	Parameter	Range	Value	Table No.
1	On/off Switch	On, Off	(0 – 1)	
2	Low Level	-64 – +63	(0 – 127)	
3	Mid Level	-64 – +63	(0 – 127)	
4	High Level	-64 – +63	(0 – 127)	
5	Low Mute	Off/On	(0 – 1)	
6	Mid Mute	Off/On	(0 – 1)	
7	High Mute	Off/On	(0 – 1)	
8	—			
9	—			
10	—			
11	—			
12	—			
13	—			
14	—			
15	—			
16	—			

[6] SLICE

No.	Parameter	Range	Value	Table No.
1	Divide Type	16th – 4th	(5 – 11)	13
2	Gate Time	0 – 100%	(0 – 100)	
3	Pan AEG Type	A – E	(0 – 4)	
4	Pan AEG Min Level	0 – 127	(0 – 127)	
5	Pan Depth	-63 – +63	(1 – 127)	
6	Divide Min Level	0 – 127	(0 – 127)	
7	Pan Type	A – J	(0 – 9)	
8	Drive	0 – 127	(0 – 127)	
9	AEG Phase	0 – 15 (x 16th note)	(0 – 15)	
10	Dry/Wet Balance	D63>W – D=W – D<W63	(1 – 127)	
11	—			
12	—			

13 – 16: Same as the parameters shaded in gray in CROSS DELAY on page 98.

[7] TECH MODULATION

No.	Parameter	Range	Value	Table No.
1	Mod Speed	0 – 127	(0 – 127)	
2	Mod Depth	0 – 127	(0 – 127)	
3	Mod Gain	-12 – +12dB	(52 – 76)	
4	Mod Mix Balance	D63>W – D=W – D<W63	(1 – 127)	
5	Pre Mod HPF Cutoff Frequency	20Hz – 8.0kHz	(0 – 52)	3
6	Mod LPF Cutoff Frequency	1.0kHz – 20.0kHz	(34 – 60)	3
7	Mod LPF Resonance	1.0 – 12.0	(10 – 120)	
8	Delay Time	0.1 – 740.0ms	(1 – 7400)	
9	Delay Time Ofst R	0 – 884	(0 – 884)	
10	Dry/Wet Balance	D63>W – D=W – D<W63	(1 – 127)	
11	Feedback Level	-63 – +63	(1 – 127)	
12	FB Level Ofst R	-63 – +63	(1 – 127)	
13	Feedback Hi Damp	0.1 – 1.0	(1 – 10)	
14	FB Hi Damp Ofst R	-0.9 – +0.9	(1 – 19)	
15	—			
16	—			

Category — MISC

[1] VCM EQ 501

No.	Parameter	Range	Value	Table No.
1	EQ1 (LSH) Frequency	31.5Hz – 2.0kHz	(12 – 84)	28
2	EQ1 (LSH) Gain	-12.0dB – +12.0dB	(60 – 300)	
3	EQ2 Q	0.50 – 16.00	(0 – 60)	29
4	EQ2 Frequency	50.0 Hz – 20.0kHz	(20 – 124)	28
5	EQ2 Gain	-18.0dB – +18.0dB	(0 – 360)	
6	EQ3 Q	0.50 – 16.00	(0 – 60)	29
7	EQ3 Frequency	50.0 Hz – 20.0kHz	(20 – 124)	28
8	EQ3 Gain	-18.0dB – +18.0dB	(0 – 360)	
9	EQ4 Q	0.50 – 16.00	(0 – 60)	29
10	EQ4 Frequency	50.0 Hz – 20.0kHz	(20 – 124)	28
11	EQ4 Gain	-18.0dB – +18.0dB	(0 – 360)	
12	EQ5 (HSH) Frequency	500Hz – 20.0kHz	(60 – 124)	28
13	EQ5 (HSH) Gain	-12.0dB – +12.0dB	(60 – 300)	
14	Output Level	-12.0dB – +12.0dB	(60 – 300)	
15	—			
16	—			

[2] HARMONIC ENHANCER

No.	Parameter	Range	Value	Table No.
1	HPF Cutoff Frequency	500Hz – 16.0kHz	(28 – 58)	3
2	Drive	0 – 127	(0 – 127)	
3	Mix Level	0 – 127	(0 – 127)	
4	—			
5	—			
6	—			
7	—			
8	—			
9	—			
10	—			
11	—			
12	—			
13	—			
14	—			
15	—			
16	—			

[3] Talking Modulator

No.	Parameter	Range	Value	Table No.
1	Vowel	a/i/u/e/o	(0 – 4)	
2	Move Speed	1 – 62	(1 – 62)	
3	Drive	0 – 127	(0 – 127)	
4	Output Level	0 – 127	(0 – 127)	
5	—			
6	—			
7	—			
8	—			
9	—			
10	—			
11	—			
12	—			
13	—			
14	—			
15	—			
16	—			

[4] DAMPER RESONANCE

No.	Parameter	Range	Value	Table No.
1	HPF Cutoff Frequency	20Hz – 8.0kHz	(0 – 52)	3
2	LPF Cutoff Frequency	1.0kHz – 20.0kHz	(34 – 60)	3
3	EQ Low Frequency	32Hz – 2.0kHz	(4 – 40)	3
4	EQ Low Gain	-12 – +12dB	(52 – 76)	
5	Hi Resonance	0.1 – 1.0	(1 – 10)	
6	Pedal Response	Slow/Normal/Fast	(0 – 2)	
7	—			
8	—			
9	—			
10	Dry/Wet Balance	D63>W – D=W – D<W63	(1 – 127)	
11	—			
12	—			
13	—			
14	—			
15	—			
16	Damper Control	0 – 127	(0 – 127)	

[5] PITCH CHANGE

No.	Parameter	Range	Value	Table No.
1	Pitch 1	-24 – +24	(40 – 88)	
2	Fine 1	-50 – +50	(14 – 114)	
3	Initial Delay 1	0.1ms – 400.0ms	(0 – 127)	7
4	Feedback Level 1	-63 – +63	(1 – 127)	
5	Pitch 2	-24 – +24	(40 – 88)	
6	Fine 2	-50 – +50	(14 – 114)	
7	Initial Delay 2	0.1ms – 400.0ms	(0 – 127)	7
8	Feedback Level 2	-63 – +63	(1 – 127)	
9	—			
10	Dry/Wet Balance	D63>W – D=W – D<W63	(1 – 127)	
11	Pan 1	L63 – C – R63	(1 – 127)	
12	Output Level 1	0 – 127	(0 – 127)	
13	Pan 2	L63 – C – R63	(1 – 127)	
14	Output Level 2	0 – 127	(0 – 127)	
15	—			
16	—			

[6] EARLY REFLECTION

No.	Parameter	Range	Value	Table No.
1	Type	S-hall, L-hall, Random, Reverse, Plate, Spring	(0 – 5)	
2	Room Size	0.1 – 20.0	(0 – 127)	6
3	Diffusion	0 – 10	(0 – 10)	
4	Initial Delay	0.1ms – 200.0ms	(0 – 127)	5
5	Feedback Level	-63 – +63	(1 – 127)	
6	HPF Cutoff Frequency	20Hz – 8.0kHz	(0 – 52)	3
7	LPF Cutoff Frequency	1.0kHz – 20.0kHz	(34 – 60)	3
8	—			
9	—			
10	Dry/Wet Balance	D63>W – D=W – D<W63	(1 – 127)	
11	Liveness	0 – 10	(0 – 10)	
12	Density	0 – 3	(0 – 3)	
13	Feedback High Damp	0.1 – 1.0	(1 – 10)	
14	—			
15	—			
16	—			

[7] NOISE GATE + COMP + EQ

No.	Parameter	Range	Value	Table No.
1	Comp Attack	1ms – 40ms	(0 – 19)	8
2	Comp Release	10ms – 680ms	(0 – 15)	9
3	Comp Threshold	-48dB – -6dB	(79 – 121)	10
4	Comp Ratio	1.0 – 20.0	(0 – 7)	
5	Comp Output Level	0 – 127	(0 – 127)	
6 – 9	Same as the parameters shaded in gray in CROSS DELAY on page 98.			
10	—			
11	Noise Gate Attack	1ms – 40ms	(0 – 19)	3
12	Noise Gate Release	10ms – 680ms	(0 – 15)	
13	Noise Gate Threshold	-73dB – -30dB	(54 – 97)	
14	EQ Mid Frequency	100Hz – 10.0kHz	(14 – 54)	
15	EQ Mid Gain	-12dB – +12dB	(52 – 76)	3
16	EQ Mid Width	0.1 – 12.0	(1 – 120)	

Insertion L Block

[0] THRU

When this type is selected, no parameters are available.

[1] VOCODER

No.	Parameter	Range	Value	Table No.
1	Formant Shift	-2, -1, 0, +1, +2	(62 – 66)	8
2	Formant Offset	-63 – +63	(1 – 127)	
3	Vocoder Attack	1ms – 200ms	(0 – 29)	
4	Vocoder Release	10ms – 3000ms	(0 – 23)	
5	Gate Switch	Off/On	(0 – 1)	9
6	Mic Gate Threshold	-72dB – -30dB	(55 – 97)	3
7	HPF Cutoff Frequency	Thru, 500Hz – 16.0kHz	(27 – 58)	
8	HPF Output Level	0 – 127	(0 – 127)	
9	—			
10	Dry/Wet Balance	D63>W – D=W – D<W63	(1 – 127)	3
11	Mic Level	0 – 127	(0 – 127)	
12	Inst Input Level	0 – 127	(0 – 127)	
13	Noise Input Level	0 – 127	(0 – 127)	
14	Output Level	0 – 127	(0 – 127)	
15	BPF1 Gain	-18dB – +18dB	(46 – 82)	
16	BPF2 Gain	-18dB – +18dB	(46 – 82)	
17	BPF3 Gain	-18dB – +18dB	(46 – 82)	
18	BPF4 Gain	-18dB – +18dB	(46 – 82)	
19	BPF5 Gain	-18dB – +18dB	(46 – 82)	
20	BPF6 Gain	-18dB – +18dB	(46 – 82)	
21	BPF7 Gain	-18dB – +18dB	(46 – 82)	
22	BPF8 Gain	-18dB – +18dB	(46 – 82)	
23	BPF9 Gain	-18dB – +18dB	(46 – 82)	
24	BPF10 Gain	-18dB – +18dB	(46 – 82)	

Master EQ Block

[0] MEQ

No.	Parameter	Range	Value	Table No.
1	EQ1 Gain	-12dB – +12dB	(52 – 76)	3
2	EQ1 Frequency	32Hz – 2.0kHz	(4 – 40)	
3	EQ1 Q	0.1 – 12.0	(1 – 120)	
4	EQ1 Shape	Shelving, Peaking	(0 – 1)	3
5	EQ2 Gain	-12dB – +12dB	(52 – 76)	
6	EQ2 Frequency	100Hz – 10kHz	(14 – 54)	
7	EQ2 Q	0.1 – 12.0	(1 – 120)	3
8	—			
9	EQ3 Gain	-12dB – +12dB	(52 – 76)	
10	EQ3 Frequency	100Hz – 10kHz	(14 – 54)	3
11	EQ3 Q	0.1 – 12.0	(1 – 120)	
12	—			
13	EQ4 Gain	-12dB – +12dB	(52 – 76)	3
14	EQ4 Frequency	100Hz – 10kHz	(14 – 54)	
15	EQ4 Q	0.1 – 12.0	(1 – 120)	
16	—			3
17	EQ5 Gain	-12dB – +12dB	(52 – 76)	
18	EQ5 Frequency	500Hz – 16kHz	(28 – 58)	
19	EQ5 Q	0.1 – 12.0	(1 – 120)	3
20	EQ5 Shape	Shelving, Peaking	(0 – 1)	

When the EQ Shape1 is set to Peaking, the range of EQ Frequency 1 is 63Hz – 2.0kHz (10 – 40).

Master Effect Block

THRU type is not included in the Master Effect Block. If you wish to bypass this block, turn the EFFECT [MASTER] button off.

DELAY L, R (Stereo)

LO-FI

COMP DISTORTION

ISOLATOR

DYNAMIC FILTER

SLICE

RING MODULATOR

MULTI BAND COMP

VCM COMPRESSOR 376

Effect Preset List

Category	Effect Type Name	Preset Name
Reverb	Rev-X Hall	Basic Small Hall Clean Church Bright Hall
	R3 Hall	Basic Big Hall Backstage Ballad Light
	SPX Hall	Basic Big Hall Backstage Light Gymnasium
	Rev-X Room	Basic Basement Garage Bedroom
	R3 Room	Basic Open Wide Tight
	SPX Room	Basic Open Wide Tight
	R3 Plate	Basic Bright Vocal Smooth Vocal Short Bright Metal Splash
	SPX Stage	Basic Small Big
	Space Simulator	Tunnel Basement Canyon White Room Small Room Live Room 3 Walls
	Delay	Control Delay
Cross Delay		Basic Short Long Very Long
Tempo Cross Delay		4beat Echo Dotted 8th Echo 8beat Echo Triplet Echo 2beat Echo
Tempo Delay Mono		4beat Echo Mono Out 4beat Dotted 8th Echo 8beat Echo Mono Out Dot8 Mono Out 8beat Triplet Echo Triplet Mono Analog Delay
Tempo Delay Stereo		4beat Echo Dotted 8th Echo 8beat Echo Triplet Echo
Delay LR		Basic Mono Doubling Short Fast Long Very Long Analog Delay Ping Pong Bounce
Delay LCR		Bounce Analog Delay
Delay LR Stereo		Basic Doubling Short
Delay LR Stereo		Fast Long Very Long Analog Delay

Category	Effect Type Name	Preset Name
Chorus	G Chorus	Basic Fast Deep Mist Bright
	2 Modulator	Basic Fast Deep Mist Multi Panning Mod Vibrator Wonder Shimmer
	SPX Chorus	Basic Fast Deep Slow Flangy
	Symphonic	Basic Fast Deep Slow Analog
	Ensemble Detune	Basic Soft Wide Deep Wide Stereo Sim
	Flanger	VCM Flanger
Classic Flanger		Basic Flange Chorus Psychedelic Jet
Tempo Flanger		Deep Mod Flange Chorus Metallic Psychedelic Jet
Dynamic Flanger		Follow Reverse Distorted Sync
Phaser	VCM Phaser Mono	E.Piano Orange90 Two Phase Deep Six Deep Eight Lite Eight Deep Sweeper Orange100 Red Twelve Blue Sixteen Clavi1 Clavi2 E.Guitar1 E.Guitar2 E.Guitar3 Vibrato1 Vibrato2 Vibrato3 Ambience1 Ambience2
	VCM Phaser Stereo	Deep Sweeper E.Piano1 E.Piano2 Clavi1 Clavi2 E.Guitar1 E.Guitar2 E.Guitar3 Deep Six Deep Eight Vibrato1
	VCM Phaser Stereo	Vibrato2 Vibrato3 Ambience1 Ambience2
	Tempo Phaser	Basic Deep Phase
	Dynamic Phaser	Follow Reverse Light

Category	Effect Type Name	Preset Name
Tremolo&Rotary	Auto Pan	E.Piano Smooth Oval Right Turn Super Slow
	Tremolo	Fast Slow Super Fast Stereo Vibrato Spring Relax
	Rotary Speaker	Basic Horn Mic Light Heavy Rotor Fast First
Distortion	Amp Simulator 1	Stack1 Stack2 Twin Boost Old Amp Transistor Modern US-Clean J-Clean Fuzz Small Blues Buzzy Bottom Beat Crunch Beat Drive
	Amp Simulator 2	Stack1 Stack2 Combo Crunch Hi Gain British Tube Drive Tube Clean
	Comp Distortion	Basic Booster School Boy Detroit Long Lead 80s Clean
	Comp Distortion Delay	Hard1 Hard2 Grunge Voodoo Texas Rockabilly LA Session Thin Techno
Compressor	VCM Compressor 376	Basic Comp Sustainer 60s DrumKit Natural Kick Old Piano Valve Tone Bass Hard Basic Fast Atk + Boost Soft Atk + Boost Attack & Tight Hard Atk + Boost Vocal Comp 117x Unplugged Attack Comp Punchy Master Pinched
	Classic Compressor	Basic Attack For Vintage Keys Pack Comp Gate Tight Pop Rhythm Cutting Comp Basic Bass Old Record Piano
	Multi Band Comp	Basic Maximizer Wild Attacky Hard Hip Club Slap Bass(ch)

Category	Effect Type Name	Preset Name
Wah	VCM Auto Wah	Low High For Bass
	VCM Touch Wah	Follow Hi Q For Bass Reverse
	VCM Pedal Wah	Low High
Lo-Fi	Lo-Fi	Lo-Fi Old Phone Overload Max Lo-Fi
	Noisy	Noisy Tremolo Noise Fuzz Noise
	Digital Turntable	Old Record1 Old Record2 Short Wave Radio
Tech	Ring Modulator	Basic Slow Tremolo Crazy
	Dynamic Ring Modulator	Basic Metallic Sputter Sharp Edge
	Dynamic Filter	Basic HiPass LoPass Squish
	Auto Synth	Echo Space Walking Robot Delay
	Isolator	Mid Only Near Flat
	Slice	Slice Beat 8th Pan 16th Mute Rock
MISC	Tec Modulation	Star Train Numerator Active Dist Astonish Drift Armor
	VCM EQ 501	Flat Radio Speaker Dance Bd & Sn
	Harmonic Enhancer	Edge Hi Edge Mid Edge
	Talking Modulator	Basic
	Damper Resonance	Basic
	Pitch Change	Detune Oct Echo Octaver Plus 4th Minus 4th Oval Step Up Step Down
	Early Reflections	Close Far Reverse Gate 70s Gate
	NOISE GATE+COMP+EQ	Basic

Effect Data Assign Table

Table #1
LFO Frequency

Data	Value	Data	Value
0	0.00	64	2.69
1	0.04	65	2.78
2	0.08	66	2.86
3	0.13	67	2.94
4	0.17	68	3.03
5	0.21	69	3.11
6	0.25	70	3.20
7	0.29	71	3.28
8	0.34	72	3.37
9	0.38	73	3.45
10	0.42	74	3.53
11	0.46	75	3.62
12	0.51	76	3.70
13	0.55	77	3.87
14	0.59	78	4.04
15	0.63	79	4.21
16	0.67	80	4.37
17	0.72	81	4.54
18	0.76	82	4.71
19	0.80	83	4.88
20	0.84	84	5.05
21	0.88	85	5.22
22	0.93	86	5.38
23	0.97	87	5.55
24	1.01	88	5.72
25	1.05	89	6.06
26	1.09	90	6.39
27	1.14	91	6.73
28	1.18	92	7.07
29	1.22	93	7.40
30	1.26	94	7.74
31	1.30	95	8.08
32	1.35	96	8.41
33	1.39	97	8.75
34	1.43	98	9.08
35	1.47	99	9.42
36	1.51	100	9.76
37	1.56	101	10.1
38	1.60	102	10.8
39	1.64	103	11.4
40	1.68	104	12.1
41	1.72	105	12.8
42	1.77	106	13.5
43	1.81	107	14.1
44	1.85	108	14.8
45	1.89	109	15.5
46	1.94	110	16.2
47	1.98	111	16.8
48	2.02	112	17.5
49	2.06	113	18.2
50	2.10	114	19.5
51	2.15	115	20.9
52	2.19	116	22.2
53	2.23	117	23.6
54	2.27	118	24.9
55	2.31	119	26.2
56	2.36	120	27.6
57	2.40	121	28.9
58	2.44	122	30.3
59	2.48	123	31.6
60	2.52	124	33.0
61	2.57	125	34.3
62	2.61	126	37.0
63	2.65	127	39.7

Table #2
Modulation Delay Offset

Data	Value	Data	Value
0	0.0	64	6.4
1	0.1	65	6.5
2	0.2	66	6.6
3	0.3	67	6.7
4	0.4	68	6.8
5	0.5	69	6.9
6	0.6	70	7.0
7	0.7	71	7.1
8	0.8	72	7.2
9	0.9	73	7.3
10	1.0	74	7.4
11	1.1	75	7.5
12	1.2	76	7.6
13	1.3	77	7.7
14	1.4	78	7.8
15	1.5	79	7.9
16	1.6	80	8.0
17	1.7	81	8.1
18	1.8	82	8.2
19	1.9	83	8.3
20	2.0	84	8.4
21	2.1	85	8.5
22	2.2	86	8.6
23	2.3	87	8.7
24	2.4	88	8.8
25	2.5	89	8.9
26	2.6	90	9.0
27	2.7	91	9.1
28	2.8	92	9.2
29	2.9	93	9.3
30	3.0	94	9.4
31	3.1	95	9.5
32	3.2	96	9.6
33	3.3	97	9.7
34	3.4	98	9.8
35	3.5	99	9.9
36	3.6	100	10.0
37	3.7	101	11.1
38	3.8	102	12.2
39	3.9	103	13.3
40	4.0	104	14.4
41	4.1	105	15.5
42	4.2	106	17.1
43	4.3	107	18.6
44	4.4	108	20.2
45	4.5	109	21.8
46	4.6	110	23.3
47	4.7	111	24.9
48	4.8	112	26.5
49	4.9	113	28.0
50	5.0	114	29.6
51	5.1	115	31.2
52	5.2	116	32.8
53	5.3	117	34.3
54	5.4	118	35.9
55	5.5	119	37.5
56	5.6	120	39.0
57	5.7	121	40.6
58	5.8	122	42.2
59	5.9	123	43.7
60	6.0	124	45.3
61	6.1	125	46.9
62	6.2	126	48.4
63	6.3	127	50.0

Table #3
EQ Frequency

Data	Value
0	THRU (20)
1	22
2	25
3	28
4	32
5	36
6	40
7	45
8	50
9	56
10	63
11	70
12	80
13	90
14	100
15	110
16	125
17	140
18	160
19	180
20	200
21	225
22	250
23	280
24	315
25	355
26	400
27	450
28	500
29	560
30	630
31	700
32	800
33	900
34	1.0k
35	1.1k
36	1.2k
37	1.4k
38	1.6k
39	1.8k
40	2.0k
41	2.2k
42	2.5k
43	2.8k
44	3.2k
45	3.6k
46	4.0k
47	4.5k
48	5.0k
49	5.6k
50	6.3k
51	7.0k
52	8.0k
53	9.0k
54	10.0k
55	11.0k
56	12.0k
57	14.0k
58	16.0k
59	18.0k
60	THRU(20.0k)

Table #4
Reverb time

Data	Value	Data	Value
0	0.3	64	17.0
1	0.4	65	18.0
2	0.5	66	19.0
3	0.6	67	20.0
4	0.7	68	25.0
5	0.8	69	30.0
6	0.9		
7	1.0		
8	1.1		
9	1.2		
10	1.3		
11	1.4		
12	1.5		
13	1.6		
14	1.7		
15	1.8		
16	1.9		
17	2.0		
18	2.1		
19	2.2		
20	2.3		
21	2.4		
22	2.5		
23	2.6		
24	2.7		
25	2.8		
26	2.9		
27	3.0		
28	3.1		
29	3.2		
30	3.3		
31	3.4		
32	3.5		
33	3.6		
34	3.7		
35	3.8		
36	3.9		
37	4.0		
38	4.1		
39	4.2		
40	4.3		
41	4.4		
42	4.5		
43	4.6		
44	4.7		
45	4.8		
46	4.9		
47	5.0		
48	5.5		
49	6.0		
50	6.5		
51	7.0		
52	7.5		
53	8.0		
54	8.5		
55	9.0		
56	9.5		
57	10.0		
58	11.0		
59	12.0		
60	13.0		
61	14.0		
62	15.0		
63	16.0		

Table #5
Delay Time (0.1 – 200.0 [ms])

Data	Value	Data	Value
0	0.1	64	100.8
1	1.7	65	102.4
2	3.2	66	104.0
3	4.8	67	105.6
4	6.4	68	107.1
5	8.0	69	108.7
6	9.5	70	110.3
7	11.1	71	111.9
8	12.7	72	113.4
9	14.3	73	115.0
10	15.8	74	116.6
11	17.4	75	118.2
12	19.0	76	119.7
13	20.6	77	121.3
14	22.1	78	122.9
15	23.7	79	124.4
16	25.3	80	126.0
17	26.9	81	127.6
18	28.4	82	129.2
19	30.0	83	130.7
20	31.6	84	132.3
21	33.2	85	133.9
22	34.7	86	135.5
23	36.3	87	137.0
24	37.9	88	138.6
25	39.5	89	140.2
26	41.0	90	141.8
27	42.6	91	143.3
28	44.2	92	144.9
29	45.7	93	146.5
30	47.3	94	148.1
31	48.9	95	149.6
32	50.5	96	151.2
33	52.0	97	152.8
34	53.6	98	154.4
35	55.2	99	155.9
36	56.8	100	157.5
37	58.3	101	159.1
38	59.9	102	160.6
39	61.5	103	162.2
40	63.1	104	163.8
41	64.6	105	165.4
42	66.2	106	166.9
43	67.8	107	168.5
44	69.4	108	170.1
45	70.9	109	171.7
46	72.5	110	173.2
47	74.1	111	174.8
48	75.7	112	176.4
49	77.2	113	178.0
50	78.8	114	179.5
51	80.4	115	181.1
52	81.9	116	182.7
53	83.5	117	184.3
54	85.1	118	185.8
55	86.7	119	187.4
56	88.2	120	189.0
57	89.8	121	190.6
58	91.4	122	192.1
59	93.0	123	193.7
60	94.5	124	195.3
61	96.1	125	196.9
62	97.7	126	198.4
63	99.3	127	200.0

Table #6
Room Size

Data	Value	Data	Value
0	0.1	64	10.1
1	0.3	65	10.3
2	0.4	66	10.4
3	0.6	67	10.6
4	0.7	68	10.8
5	0.9	69	10.9
6	1.0	70	11.1
7	1.2	71	11.2
8	1.4	72	11.4
9	1.5	73	11.5
10	1.7	74	11.7
11	1.8	75	11.9
12	2.0	76	12.0
13	2.1	77	12.2
14	2.3	78	12.3
15	2.5	79	12.5
16	2.6	80	12.6
17	2.8	81	12.8
18	2.9	82	12.9
19	3.1	83	13.1
20	3.2	84	13.3
21	3.4	85	13.4
22	3.5	86	13.6
23	3.7	87	13.7
24	3.9	88	13.9
25	4.0	89	14.0
26	4.2	90	14.2
27	4.3	91	14.4
28	4.5	92	14.5
29	4.6	93	14.7
30	4.8	94	14.8
31	5.0	95	15.0
32	5.1	96	15.1
33	5.3	97	15.3
34	5.4	98	15.5
35	5.6	99	15.6
36	5.7	100	15.8
37	5.9	101	15.9
38	6.1	102	16.1
39	6.2	103	16.2
40	6.4	104	16.4
41	6.5	105	16.6
42	6.7	106	16.7
43	6.8	107	16.9
44	7.0	108	17.0
45	7.2	109	17.2
46	7.3	110	17.3
47	7.5	111	17.5
48	7.6	112	17.6
49	7.8	113	17.8
50	7.9	114	18.0
51	8.1	115	18.1
52	8.2	116	18.3
53	8.4	117	18.4
54	8.6	118	18.6
55	8.7	119	18.7
56	8.9	120	18.9
57	9.0	121	19.1
58	9.2	122	19.2
59	9.3	123	19.4
60	9.5	124	19.5
61	9.7	125	19.7
62	9.8	126	19.8
63	10.0	127	20.0

Table #7
Delay Time (0.1 – 400.0 [ms])

Data	Value	Data	Value
0	0.1	64	201.6
1	3.2	65	204.8
2	6.4	66	207.9
3	9.5	67	211.1
4	12.7	68	214.2
5	15.8	69	217.4
6	19.0	70	220.5
7	22.1	71	223.7
8	25.3	72	226.8
9	28.4	73	230.0
10	31.6	74	233.1
11	34.7	75	236.3
12	37.9	76	239.4
13	41.0	77	242.6
14	44.2	78	245.7
15	47.3	79	248.9
16	50.5	80	252.0
17	53.6	81	255.2
18	56.8	82	258.3
19	59.9	83	261.5
20	63.1	84	264.6
21	66.2	85	267.7
22	69.4	86	270.9
23	72.5	87	274.0
24	75.7	88	277.2
25	78.8	89	280.3
26	82.0	90	283.5
27	85.1	91	286.6
28	88.3	92	289.8
29	91.4	93	292.9
30	94.6	94	296.1
31	97.7	95	299.2
32	100.9	96	302.4
33	104.0	97	305.5
34	107.2	98	308.7
35	110.3	99	311.8
36	113.5	100	315.0
37	116.6	101	318.1
38	119.8	102	321.3
39	122.9	103	324.4
40	126.1	104	327.6
41	129.2	105	330.7
42	132.4	106	333.9
43	135.5	107	337.0
44	138.6	108	340.2
45	141.8	109	343.3
46	144.9	110	346.5
47	148.1	111	349.6
48	151.2	112	352.8
49	154.4	113	355.9
50	157.5	114	359.1
51	160.7	115	362.2
52	163.8	116	365.4
53	167.0	117	368.5
54	170.1	118	371.7
55	173.3	119	374.8
56	176.4	120	378.0
57	179.6	121	381.1
58	182.7	122	384.3
59	185.9	123	387.4
60	189.0	124	390.6
61	192.2	125	393.7
62	195.3	126	396.9
63	198.5	127	400.0

Table #8
Compressor/Vocoder Attack Time

Data	Value
0	1
1	2
2	3
3	4
4	5
5	6
6	7
7	8
8	9
9	10
10	12
11	14
12	16
13	18
14	20
15	23
16	26
17	30
18	35
19	40
20	50
21	60
22	70
23	80
24	100
25	120
26	140
27	160
28	180
29	200

Table #9
Compressor/Vocoder Release Time

Data	Value
0	10
1	15
2	25
3	35
4	45
5	55
6	65
7	75
8	85
9	100
10	115
11	140
12	170
13	230
14	340
15	680
16	850
17	1000
18	1200
19	1500
20	1700
21	2000
22	2400
23	3000

Table #10
Compressor Ratio

Data	Value
0	1.0
1	1.5
2	2.0
3	3.0
4	5.0
5	7.0
6	10.0
7	20.0

Table #11
Reverb Width; Depth; Height

Data	Value	Data	Value
0	0.5	64	17.6
1	0.8	65	17.9
2	1.0	66	18.2
3	1.3	67	18.5
4	1.5	68	18.8
5	1.8	69	19.1
6	2.0	70	19.4
7	2.3	71	19.7
8	2.6	72	20.0
9	2.8	73	20.2
10	3.1	74	20.5
11	3.3	75	20.8
12	3.6	76	21.1
13	3.9	77	21.4
14	4.1	78	21.7
15	4.4	79	22.0
16	4.6	80	22.4
17	4.9	81	22.7
18	5.2	82	23.0
19	5.4	83	23.3
20	5.7	84	23.6
21	5.9	85	23.9
22	6.2	86	24.2
23	6.5	87	24.5
24	6.7	88	24.9
25	7.0	89	25.2
26	7.2	90	25.5
27	7.5	91	25.8
28	7.8	92	26.1
29	8.0	93	26.5
30	8.3	94	26.8
31	8.6	95	27.1
32	8.8	96	27.5
33	9.1	97	27.8
34	9.4	98	28.1
35	9.6	99	28.5
36	9.9	100	28.8
37	10.2	101	29.2
38	10.4	102	29.5
39	10.7	103	29.9
40	11.0	104	30.2
41	11.2		
42	11.5		
43	11.8		
44	12.1		
45	12.3		
46	12.6		
47	12.9		
48	13.1		
49	13.4		
50	13.7		
51	14.0		
52	14.2		
53	14.5		
54	14.8		
55	15.1		
56	15.4		
57	15.6		
58	15.9		
59	16.2		
60	16.5		
61	16.8		
62	17.1		
63	17.3		

Table #12
LO-FI Sampling Frequency Control

Data	Value	Data	Value
0	44.1k	64	678.5
1	22.1k	65	668.2
2	14.7k	66	658.2
3	11.0k	67	648.5
4	8.82k	68	639.1
5	7.35k	69	630.0
6	6.30k	70	621.1
7	5.51k	71	612.5
8	4.90k	72	604.1
9	4.41k	73	595.9
10	4.01k	74	588.0
11	3.68k	75	580.3
12	3.39k	76	572.7
13	3.15k	77	565.4
14	2.94k	78	558.2
15	2.76k	79	551.3
16	2.59k	80	544.4
17	2.45k	81	537.8
18	2.32k	82	531.3
19	2.21k	83	525.0
20	2.10k	84	518.8
21	2.00k	85	512.8
22	1.92k	86	506.9
23	1.84k	87	501.1
24	1.76k	88	495.5
25	1.70k	89	490.0
26	1.63k	90	484.6
27	1.58k	91	479.3
28	1.52k	92	474.2
29	1.47k	93	469.1
30	1.42k	94	464.2
31	1.38k	95	459.4
32	1.34k	96	454.6
33	1.30k	97	450.0
34	1.26k	98	445.5
35	1.23k	99	441.0
36	1.19k	100	436.6
37	1.16k	101	432.4
38	1.13k	102	428.2
39	1.10k	103	424.0
40	1.08k	104	420.0
41	1.05k	105	416.0
42	1.03k	106	412.1
43	1.00k	107	408.3
44	980.0	108	404.6
45	958.7	109	400.9
46	938.3	110	397.3
47	918.8	111	393.8
48	900.0	112	390.3
49	882.0	113	386.8
50	864.7	114	383.5
51	848.1	115	380.2
52	832.1	116	376.9
53	816.7	117	373.7
54	801.8	118	370.6
55	787.5	119	367.5
56	773.7	120	364.5
57	760.3	121	361.5
58	747.5	122	358.5
59	735.0	123	355.6
60	723.0	124	352.8
61	711.3	125	350.0
62	700.0	126	347.2
63	689.1	127	344.5

Table #13
Tempo

Data	Value
0	32nd/3
1	64th.
2	32nd
3	16th/3
4	32nd.
5	16th
6	8th/3
7	16th.
8	8th
9	4th/3
10	8th.
11	4th
12	2nd/3
13	4th.
14	2nd
15	Whole/3
16	2nd.
17	4thX4
18	4thX5
19	4thX6
20	4thX7
21	4thX8
22	4thX9
23	4thX10
24	4thX11
25	4thX12
26	4thX13
27	4thX14
28	4thX15
29	4thX16

Table #14
Multi Compressor
Gain (dB)

Data	Value
0	-∞
1	-60
2	-57
3	-54
4	-51
5	-48
6	-45
7	-42
8	-39
9	-36
10	-33
11	-30
12	-27
13	-24
14	-23
15	-22
16	-21
17	-20
18	-19
19	-18
20	-17
21	-16
22	-15
23	-14
24	-13
25	-12
26	-11
27	-10
28	-9
29	-8
30	-7
31	-6
32	-5
33	-4
34	-3
35	-2
36	-1
37	0
38	1
39	2
40	3
41	4
42	5
43	6
44	7
45	8
46	9
47	10
48	11
49	12
50	13
51	14
52	15
53	16
54	17
55	18

Table #15
Dyna Attack Time (ms)

Data	Value	Data	Value
0	0.3	64	112
1	0.9	65	114
2	1.8	66	116
3	2.7	67	118
4	3.6	68	120
5	5.4	69	121
6	7.2	70	123
7	9.0	71	125
8	10	72	127
9	12	73	129
10	14	74	130
11	16	75	132
12	18	76	134
13	20	77	136
14	21	78	138
15	23	79	140
16	25	80	141
17	27	81	143
18	29	82	145
19	30	83	147
20	32	84	149
21	34	85	150
22	36	86	152
23	38	87	154
24	40	88	156
25	41	89	158
26	43	90	160
27	45	91	161
28	47	92	163
29	49	93	165
30	50	94	167
31	52	95	169
32	54	96	170
33	56	97	172
34	58	98	174
35	60	99	176
36	61	100	178
37	63	101	180
38	65	102	181
39	67	103	183
40	69	104	185
41	70	105	187
42	72	106	189
43	74	107	190
44	76	108	192
45	78	109	194
46	80	110	196
47	81	111	198
48	83	112	200
49	85	113	201
50	87	114	203
51	89	115	205
52	90	116	207
53	92	117	209
54	94	118	210
55	96	119	212
56	98	120	214
57	100	121	216
58	101	122	218
59	103	123	220
60	105	124	221
61	107	125	223
62	109	126	225
63	110	127	227

Table #16
Dyna Release Time (ms)

Data	Value	Data	Value
0	2.6	64	369
1	3.0	65	391
2	3.4	66	413
3	3.9	67	434
4	4.3	68	456
5	4.7	69	478
6	5.2	70	499
7	5.6	71	521
8	6.0	72	543
9	6.5	73	565
10	6.9	74	586
11	7.3	75	608
12	7.8	76	630
13	8.2	77	651
14	8.6	78	673
15	13	79	695
16	17	80	717
17	22	81	738
18	26	82	760
19	30	83	782
20	35	84	803
21	39	85	825
22	43	86	847
23	48	87	869
24	52	88	890
25	56	89	912
26	61	90	934
27	65	91	955
28	69	92	977
29	74	93	999
30	78	94	1021
31	83	95	1042
32	87	96	1064
33	91	97	1086
34	96	98	1107
35	100	99	1129
36	104	100	1151
37	109	101	1173
38	113	102	1194
39	117	103	1216
40	122	104	1238
41	126	105	1259
42	130	106	1281
43	135	107	1303
44	139	108	1346
45	143	109	1390
46	148	110	1433
47	152	111	1477
48	156	112	1520
49	161	113	1563
50	165	114	1607
51	169	115	1650
52	174	116	1694
53	178	117	1737
54	182	118	1781
55	187	119	1824
56	195	120	1867
57	217	121	1911
58	239	122	1954
59	261	123	1998
60	282	124	2041
61	304	125	2085
62	326	126	2128
63	347	127	2171

Table #17
Ring Mod OSC Freq Coarse (Hz)

Data	Value	Data	Value
0	0.5	64	151
1	1.5	65	160
2	2.0	66	169
3	2.5	67	179
4	3.5	68	189
5	4.0	69	200
6	4.5	70	211
7	5.5	71	223
8	6.0	72	236
9	6.5	73	249
10	7.5	74	264
11	8.0	75	279
12	8.4	76	295
13	8.9	77	311
14	9.4	78	329
15	9.9	79	348
16	10.5	80	368
17	11.1	81	389
18	11.7	82	411
19	12.4	83	435
20	13.1	84	459
21	13.9	85	486
22	14.7	86	513
23	15.5	87	543
24	16.4	88	574
25	17.3	89	607
26	18.3	90	641
27	19.4	91	678
28	20.5	92	717
29	21.7	93	757
30	22.9	94	801
31	24.2	95	846
32	25.6	96	895
33	27.1	97	946
34	28.6	98	1.00k
35	30.3	99	1.05k
36	32.0	100	1.11k
37	33.8	101	1.18k
38	35.8	102	1.24k
39	37.8	103	1.32k
40	40.0	104	1.39k
41	42.2	105	1.47k
42	44.7	106	1.55k
43	47.2	107	1.64k
44	49.9	108	1.74k
45	52.7	109	1.84k
46	55.8	110	1.94k
47	58.9	111	2.05k
48	62.3	112	2.17k
49	65.9	113	2.29k
50	69.6	114	2.43k
51	73.6	115	2.56k
52	77.8	116	2.71k
53	82.3	117	2.87k
54	87.0	118	3.03k
55	91.9	119	3.20k
56	97.2	120	3.39k
57	102	121	3.58k
58	108	122	3.79k
59	114	123	4.00k
60	121	124	4.23k
61	128	125	4.47k
62	135	126	4.73k
63	143	127	5.00k

Table #18
V-Flanger Delay Offset

Data	Value	Data	Value	Data	Value
0	0.09	64	4.72	128	31.38
1	0.11	65	4.96	129	31.82
2	0.13	66	5.21	130	32.25
3	0.15	67	5.47	131	32.69
4	0.18	68	5.75	132	33.13
5	0.20	69	6.04	133	33.57
6	0.22	70	6.35	134	34.01
7	0.24	71	6.67	135	34.45
8	0.27	72	7.01	136	34.89
9	0.29	73	7.37	137	35.33
10	0.31	74	7.74	138	35.77
11	0.34	75	8.13	139	36.21
12	0.36	76	8.54		
13	0.38	77	8.97		
14	0.40	78	9.41		
15	0.42	79	9.85		
16	0.43	80	10.29		
17	0.46	81	10.73		
18	0.48	82	11.17		
19	0.51	83	11.61		
20	0.53	84	12.05		
21	0.56	85	12.49		
22	0.59	86	12.93		
23	0.62	87	13.37		
24	0.65	88	13.81		
25	0.68	89	14.24		
26	0.72	90	14.68		
27	0.76	91	15.12		
28	0.79	92	15.56		
29	0.83	93	16.00		
30	0.88	94	16.44		
31	0.92	95	16.88		
32	0.97	96	17.32		
33	1.02	97	17.76		
34	1.07	98	18.20		
35	1.12	99	18.64		
36	1.18	100	19.08		
37	1.24	101	19.52		
38	1.30	102	19.96		
39	1.37	103	20.40		
40	1.44	104	20.83		
41	1.51	105	21.27		
42	1.59	106	21.71		
43	1.67	107	22.15		
44	1.76	108	22.59		
45	1.84	109	23.03		
46	1.94	110	23.47		
47	2.04	111	23.91		
48	2.14	112	24.35		
49	2.25	113	24.79		
50	2.36	114	25.23		
51	2.48	115	25.66		
52	2.61	116	26.10		
53	2.74	117	26.54		
54	2.88	118	26.98		
55	3.03	119	27.42		
56	3.18	120	27.86		
57	3.34	121	28.30		
58	3.51	122	28.74		
59	3.69	123	29.18		
60	3.87	124	29.62		
61	4.07	125	30.06		
62	4.28	126	30.50		
63	4.49	127	30.94		

Table #19
Modulation Phase

Data	Value
0	-180
1	-158
2	-135
3	-113
4	-90
5	-68
6	-45
7	-23
8	0
9	23
10	45
11	68
12	90
13	113
14	135
15	158
16	180

Table #20
VCM Flanger Speed

Data	Value	Data	Value	Data	Value	Data	Value
0	0.040	64	0.247	128	0.988	192	3.953
1	0.042	65	0.252	129	1.009	193	4.037
2	0.045	66	0.258	130	1.030	194	4.122
3	0.047	67	0.263	131	1.051	195	4.206
4	0.050	68	0.268	132	1.072	196	4.290
5	0.053	69	0.273	133	1.093	197	4.374
6	0.055	70	0.281	134	1.125	198	4.500
7	0.058	71	0.287	135	1.146	199	4.584
8	0.060	72	0.292	136	1.167	200	4.668
9	0.063	73	0.300	137	1.199	201	4.752
10	0.066	74	0.308	138	1.220	202	4.879
11	0.068	75	0.313	139	1.251	203	5.005
12	0.071	76	0.321	140	1.272	204	5.131
13	0.074	77	0.326	141	1.304	205	5.215
14	0.076	78	0.334	142	1.335	206	5.341
15	0.079	79	0.342	143	1.367	207	5.467
16	0.081	80	0.347	144	1.409	208	5.552
17	0.084	81	0.357	145	1.430	209	5.720
18	0.087	82	0.363	146	1.451	210	5.804
19	0.089	83	0.373	147	1.493	211	5.972
20	0.092	84	0.379	148	1.514	212	6.056
21	0.095	85	0.389	149	1.556	213	6.224
22	0.097	86	0.400	150	1.577	214	6.309
23	0.100	87	0.405	151	1.619	215	6.477
24	0.102	88	0.415	152	1.661	216	6.645
25	0.105	89	0.426	153	1.682	217	6.813
26	0.108	90	0.431	154	1.724	218	6.897
27	0.110	91	0.442	155	1.766	219	7.066
28	0.113	92	0.452	156	1.808	220	7.234
29	0.116	93	0.463	157	1.851	221	7.402
30	0.118	94	0.473	158	1.893	222	7.570
31	0.121	95	0.484	159	1.935	223	7.738
32	0.124	96	0.494	160	1.977	224	7.907
33	0.126	97	0.505	161	2.019	225	8.075
34	0.129	98	0.515	162	2.061	226	8.243
35	0.131	99	0.526	163	2.103	227	8.411
36	0.134	100	0.536	164	2.145	228	8.580
37	0.137	101	0.547	165	2.187	229	8.748
38	0.139	102	0.563	166	2.250	230	9.000
39	0.145	103	0.573	167	2.292	231	9.168
40	0.147	104	0.589	168	2.334	232	9.337
41	0.150	105	0.599	169	2.397	233	9.589
42	0.152	106	0.615	170	2.460	234	9.757
43	0.158	107	0.626	171	2.502	235	10.00
44	0.160	108	0.636	172	2.565		
45	0.163	109	0.652	173	2.608		
46	0.168	110	0.668	174	2.671		
47	0.171	111	0.683	175	2.733		
48	0.173	112	0.704	176	2.776		
49	0.179	113	0.715	177	2.860		
50	0.181	114	0.725	178	2.902		
51	0.187	115	0.747	179	2.986		
52	0.189	116	0.757	180	3.028		
53	0.195	117	0.778	181	3.112		
54	0.197	118	0.789	182	3.154		
55	0.202	119	0.810	183	3.238		
56	0.208	120	0.831	184	3.323		
57	0.210	121	0.852	185	3.365		
58	0.216	122	0.862	186	3.449		
59	0.221	123	0.883	187	3.533		
60	0.226	124	0.904	188	3.617		
61	0.231	125	0.925	189	3.701		
62	0.237	126	0.946	190	3.785		
63	0.242	127	0.967	191	3.869		

Table #21
VCM Phaser Speed

Data	Value	Data	Value	Data	Value	Data	Value
0	0.100	64	0.334	128	1.062	192	3.365
1	0.103	65	0.342	129	1.083	193	3.449
2	0.105	66	0.347	130	1.104	194	3.491
3	0.108	67	0.357	131	1.125	195	3.575
4	0.110	68	0.363	132	1.146	196	3.659
5	0.113	69	0.368	133	1.167	197	3.701
6	0.116	70	0.373	134	1.188	198	3.785
7	0.118	71	0.379	135	1.209	199	3.827
8	0.121	72	0.389	136	1.230	200	3.911
9	0.124	73	0.394	137	1.251	201	3.995
10	0.126	74	0.400	138	1.272	202	4.080
11	0.129	75	0.410	139	1.304	203	4.122
12	0.131	76	0.415	140	1.325	204	4.206
13	0.134	77	0.426	141	1.346	205	4.290
14	0.137	78	0.431	142	1.367	206	4.374
15	0.139	79	0.442	143	1.410	207	4.458
16	0.142	80	0.447	144	1.430	208	4.500
17	0.145	81	0.457	145	1.451	209	4.584
18	0.147	82	0.463	146	1.472	210	4.668
19	0.150	83	0.473	147	1.493	211	4.752
20	0.152	84	0.478	148	1.535	212	4.837
21	0.155	85	0.489	149	1.556	213	4.921
22	0.158	86	0.499	150	1.577	214	5.047
23	0.160	87	0.510	151	1.619	215	5.131
24	0.163	88	0.515	152	1.640	216	5.215
25	0.166	89	0.526	153	1.682	217	5.299
26	0.168	90	0.536	154	1.703	218	5.383
27	0.171	91	0.547	155	1.724	219	5.551
28	0.173	92	0.557	156	1.767	220	5.636
29	0.179	93	0.568	157	1.808	221	5.720
30	0.181	94	0.578	158	1.829	222	5.804
31	0.184	95	0.589	159	1.872	223	5.888
32	0.187	96	0.599	160	1.893	224	6.056
33	0.192	97	0.610	161	1.935	225	6.140
34	0.195	98	0.620	162	1.977	226	6.224
35	0.200	99	0.631	163	2.000	227	6.393
36	0.202	100	0.641	164	2.040	228	6.477
37	0.205	101	0.652	165	2.082	229	6.561
38	0.210	102	0.668	166	2.124	230	6.729
39	0.213	103	0.683	167	2.145	231	6.813
40	0.218	104	0.694	168	2.187	232	6.981
41	0.221	105	0.704	169	2.229	233	7.066
42	0.226	106	0.715	170	2.271	234	7.234
43	0.229	107	0.725	171	2.313	235	7.318
44	0.234	108	0.747	172	2.355	236	7.486
45	0.237	109	0.758	173	2.397	237	7.654
46	0.242	110	0.768	174	2.439	238	7.774
47	0.247	111	0.789	175	2.503	239	7.907
48	0.250	112	0.799	176	2.544	240	8.075
49	0.255	113	0.810	177	2.587	241	8.159
50	0.260	114	0.831	178	2.629	242	8.327
51	0.265	115	0.841	179	2.671	243	8.496
52	0.271	116	0.862	180	2.734	244	8.664
53	0.276	117	0.873	181	2.776	245	8.832
54	0.281	118	0.894	182	2.860	246	9.000
55	0.287	119	0.904	183	2.902	247	9.168
56	0.289	120	0.925	184	2.944	248	9.337
57	0.294	121	0.936	185	2.986	249	9.505
58	0.300	122	0.957	186	3.028	250	9.673
59	0.308	123	0.967	187	3.070	251	9.841
60	0.310	124	0.988	188	3.154	252	10.00
61	0.318	125	1.000	189	3.196		
62	0.323	126	1.030	190	3.280		
63	0.329	127	1.051	191	3.323		

Table #22
VCM Wah Speed

Data	Value	Data	Value	Data	Value	Data	Value
0	0.100	64	0.384	128	1.451	192	5.552
1	0.103	65	0.394	129	1.493	193	5.636
2	0.105	66	0.405	130	1.514	194	5.720
3	0.108	67	0.410	131	1.556	195	5.888
4	0.110	68	0.421	132	1.598	196	5.972
5	0.113	69	0.426	133	1.619	197	6.140
6	0.116	70	0.436	134	1.661	198	6.224
7	0.118	71	0.447	135	1.703	199	6.393
8	0.121	72	0.457	136	1.724	200	6.477
9	0.124	73	0.463	137	1.766	201	6.665
10	0.126	74	0.473	138	1.808	202	6.813
11	0.129	75	0.484	139	1.851	203	6.897
12	0.131	76	0.494	140	1.872	204	7.066
13	0.134	77	0.505	141	1.914	205	7.234
14	0.137	78	0.515	142	1.956	206	7.402
15	0.139	79	0.526	143	1.999	207	7.570
16	0.142	80	0.536	144	2.040	208	7.654
17	0.145	81	0.547	145	2.082	209	7.823
18	0.147	82	0.563	146	2.124	210	7.991
19	0.152	83	0.573	147	2.166	211	8.159
20	0.155	84	0.584	148	2.229	212	8.327
21	0.157	85	0.599	149	2.250	213	8.496
22	0.163	86	0.610	150	2.313	214	8.748
23	0.166	87	0.620	151	2.355	215	8.916
24	0.168	88	0.636	152	2.397	216	9.084
25	0.173	89	0.652	153	2.460	217	9.253
26	0.176	90	0.662	154	2.502	218	9.505
27	0.179	91	0.673	155	2.566	219	9.673
28	0.184	92	0.694	156	2.608	220	9.841
29	0.187	93	0.704	157	2.671	221	10.09
30	0.189	94	0.725	158	2.734	222	10.26
31	0.195	95	0.736	159	2.776	223	10.51
32	0.200	96	0.747	160	2.818	224	10.77
33	0.202	97	0.768	161	2.902	225	10.93
34	0.208	98	0.778	162	2.944	226	11.10
35	0.210	99	0.799	163	3.028	227	11.44
36	0.216	100	0.820	164	3.070	228	11.61
37	0.221	101	0.831	165	3.154	229	11.94
38	0.226	102	0.852	166	3.196	230	12.11
39	0.231	103	0.873	167	3.280	231	12.45
40	0.234	104	0.883	168	3.336	232	12.62
41	0.239	105	0.904	169	3.407	233	12.95
42	0.244	106	0.935	170	3.491	234	13.29
43	0.250	107	0.946	171	3.575	235	13.46
44	0.255	108	0.967	172	3.659	236	13.79
45	0.260	109	0.988	173	3.701	237	13.96
46	0.265	110	0.999	174	3.785	238	14.30
47	0.271	111	1.020	175	3.869	239	14.64
48	0.276	112	1.051	176	3.953	240	14.97
49	0.284	113	1.072	177	4.037	241	15.31
50	0.289	114	1.093	178	4.122	242	15.65
51	0.294	115	1.115	179	4.206	243	15.98
52	0.302	116	1.136	180	4.290	244	16.32
53	0.308	117	1.157	181	4.374	245	16.65
54	0.315	118	1.188	182	4.500	246	16.99
55	0.321	119	1.209	183	4.584	247	17.33
56	0.326	120	1.241	184	4.668	248	17.66
57	0.334	121	1.262	185	4.795	249	18.00
58	0.342	122	1.293	186	4.879	250	18.34
59	0.347	123	1.314	187	4.963	251	18.84
60	0.357	124	1.346	188	5.090	252	19.18
61	0.363	125	1.367	189	5.173	253	19.51
62	0.368	126	1.409	190	5.299	254	20.00
63	0.379	127	1.430	191	5.383		

Table #23
Rev Hall Time

Data	Value	Data	Value
0	0.3	64	13.5
1	0.4	65	14.0
2	0.5	66	15.0
3	0.6	67	16.0
4	0.7	68	17.0
5	0.8	69	18.0
6	0.9		
7	1.0		
8	1.1		
9	1.2		
10	1.3		
11	1.4		
12	1.5		
13	1.6		
14	1.7		
15	1.8		
16	1.9		
17	2.0		
18	2.1		
19	2.2		
20	2.3		
21	2.4		
22	2.5		
23	2.6		
24	2.7		
25	2.8		
26	2.9		
27	3.0		
28	3.1		
29	3.2		
30	3.3		
31	3.4		
32	3.5		
33	3.6		
34	3.7		
35	3.8		
36	3.9		
37	4.0		
38	4.1		
39	4.2		
40	4.3		
41	4.4		
42	4.5		
43	4.6		
44	4.7		
45	4.8		
46	4.9		
47	5.0		
48	5.5		
49	6.0		
50	6.5		
51	7.0		
52	7.5		
53	8.0		
54	8.5		
55	9.0		
56	9.5		
57	10.0		
58	10.5		
59	11.0		
60	11.5		
61	12.0		
62	12.5		
63	13.0		

Table #24
Rev Room Time

Data	Value	Data	Value
0	0.3	64	6.7
1	0.4	65	6.8
2	0.5	66	6.9
3	0.6	67	7.0
4	0.7	68	8.0
5	0.8	69	10.0
6	0.9		
7	1.0		
8	1.1		
9	1.2		
10	1.3		
11	1.4		
12	1.5		
13	1.6		
14	1.7		
15	1.8		
16	1.9		
17	2.0		
18	2.1		
19	2.2		
20	2.3		
21	2.4		
22	2.5		
23	2.6		
24	2.7		
25	2.8		
26	2.9		
27	3.0		
28	3.1		
29	3.2		
30	3.3		
31	3.4		
32	3.5		
33	3.6		
34	3.7		
35	3.8		
36	3.9		
37	4.0		
38	4.1		
39	4.2		
40	4.3		
41	4.4		
42	4.5		
43	4.6		
44	4.7		
45	4.8		
46	4.9		
47	5.0		
48	5.1		
49	5.2		
50	5.3		
51	5.4		
52	5.5		
53	5.6		
54	5.7		
55	5.8		
56	5.9		
57	6.0		
58	6.1		
59	6.2		
60	6.3		
61	6.4		
62	6.5		
63	6.6		

Table #25
VCM Comp Level

Data	Value	Data	Value	Data	Value	Data	Value
0	-∞dB	64	-29.69dB	128	-11.63dB	192	-1.06dB
1	-138.0dB	65	-29.29dB	129	-11.43dB	193	-0.93dB
2	-120.0dB	66	-28.89dB	130	-11.23dB	194	-0.79dB
3	-109.4dB	67	-28.50dB	131	-11.03dB	195	-0.66dB
4	-101.9dB	68	-28.11dB	132	-10.83dB	196	-0.53dB
5	-96.12dB	69	-27.73dB	133	-10.63dB	197	-0.39dB
6	-91.37dB	70	-27.36dB	134	-10.44dB	198	-0.26dB
7	-87.36dB	71	-26.99dB	135	-10.24dB	199	-0.13dB
8	-83.88dB	72	-26.62dB	136	-10.05dB	200	0.00dB
9	-80.81dB	73	-26.26dB	137	-9.86dB		
10	-78.06dB	74	-25.91dB	138	-9.67dB		
11	-75.58dB	75	-25.56dB	139	-9.48dB		
12	-73.31dB	76	-25.21dB	140	-9.29dB		
13	-71.23dB	77	-24.87dB	141	-9.11dB		
14	-69.29dB	78	-24.54dB	142	-8.92dB		
15	-67.50dB	79	-24.20dB	143	-8.74dB		
16	-65.81dB	80	-23.88dB	144	-8.56dB		
17	-64.23dB	81	-23.55dB	145	-8.38dB		
18	-62.75dB	82	-23.23dB	146	-8.20dB		
19	-61.34dB	83	-22.92dB	147	-8.02dB		
20	-60.00dB	84	-22.61dB	148	-7.85dB		
21	-58.73dB	85	-22.30dB	149	-7.67dB		
22	-57.52dB	86	-21.99dB	150	-7.50dB		
23	-56.36dB	87	-21.69dB	151	-7.32dB		
24	-55.25dB	88	-21.39dB	152	-7.15dB		
25	-54.19dB	89	-21.10dB	153	-6.98dB		
26	-53.16dB	90	-20.81dB	154	-6.81dB		
27	-52.18dB	91	-20.52dB	155	-6.64dB		
28	-51.23dB	92	-20.23dB	156	-6.47dB		
29	-50.32dB	93	-19.95dB	157	-6.31dB		
30	-49.43dB	94	-19.67dB	158	-6.14dB		
31	-48.58dB	95	-19.40dB	159	-5.98dB		
32	-47.75dB	96	-19.13dB	160	-5.81dB		
33	-46.95dB	97	-18.86dB	161	-5.65dB		
34	-46.17dB	98	-18.59dB	162	-5.49dB		
35	-45.42dB	99	-18.32dB	163	-5.33dB		
36	-44.68dB	100	-18.06dB	164	-5.17dB		
37	-43.97dB	101	-17.80dB	165	-5.01dB		
38	-43.27dB	102	-17.55dB	166	-4.86dB		
39	-42.60dB	103	-17.29dB	167	-4.70dB		
40	-41.94dB	104	-17.04dB	168	-4.54dB		
41	-41.29dB	105	-16.79dB	169	-4.39dB		
42	-40.67dB	106	-16.54dB	170	-4.23dB		
43	-40.05dB	107	-16.30dB	171	-4.08dB		
44	-39.45dB	108	-16.06dB	172	-3.93dB		
45	-38.87dB	109	-15.82dB	173	-3.78dB		
46	-38.30dB	110	-15.58dB	174	-3.63dB		
47	-37.74dB	111	-15.34dB	175	-3.48dB		
48	-37.19dB	112	-15.11dB	176	-3.33dB		
49	-36.65dB	113	-14.88dB	177	-3.18dB		
50	-36.12dB	114	-14.65dB	178	-3.04dB		
51	-35.61dB	115	-14.42dB	179	-2.89dB		
52	-35.10dB	116	-14.19dB	180	-2.75dB		
53	-34.61dB	117	-13.97dB	181	-2.60dB		
54	-34.12dB	118	-13.75dB	182	-2.46dB		
55	-33.64dB	119	-13.53dB	183	-2.31dB		
56	-33.17dB	120	-13.31dB	184	-2.17dB		
57	-32.71dB	121	-13.09dB	185	-2.03dB		
58	-32.26dB	122	-12.88dB	186	-1.89dB		
59	-31.81dB	123	-12.67dB	187	-1.75dB		
60	-31.37dB	124	-12.46dB	188	-1.61dB		
61	-30.94dB	125	-12.25dB	189	-1.47dB		
62	-30.52dB	126	-12.04dB	190	-1.34dB		
63	-30.10dB	127	-11.83dB	191	-1.20dB		

Table #26
VCM Comp Attack Time

Data	Value	Data	Value	Data	Value	Data	Value
0	0.022ms	64	2.941ms	128	16.53ms	192	45.51ms
1	0.023ms	65	3.056ms	129	16.86ms	193	46.10ms
2	0.024ms	66	3.174ms	130	17.18ms	194	46.70ms
3	0.025ms	67	3.295ms	131	17.52ms	195	47.31ms
4	0.026ms	68	3.418ms	132	17.85ms	196	47.91ms
5	0.028ms	69	3.544ms	133	18.19ms	197	48.53ms
6	0.031ms	70	3.673ms	134	18.53ms	198	49.15ms
7	0.035ms	71	3.805ms	135	18.88ms	199	49.77ms
8	0.039ms	72	3.940ms	136	19.23ms	200	50.40ms
9	0.045ms	73	4.077ms	137	19.59ms		
10	0.051ms	74	4.217ms	138	19.95ms		
11	0.059ms	75	4.361ms	139	20.31ms		
12	0.068ms	76	4.507ms	140	20.68ms		
13	0.077ms	77	4.656ms	141	21.05ms		
14	0.088ms	78	4.807ms	142	21.42ms		
15	0.101ms	79	4.962ms	143	21.80ms		
16	0.114ms	80	5.120ms	144	22.18ms		
17	0.129ms	81	5.281ms	145	22.57ms		
18	0.146ms	82	5.445ms	146	22.96ms		
19	0.163ms	83	5.611ms	147	23.36ms		
20	0.182ms	84	5.781ms	148	23.75ms		
21	0.203ms	85	5.954ms	149	24.16ms		
22	0.225ms	86	6.130ms	150	24.56ms		
23	0.249ms	87	6.309ms	151	24.97ms		
24	0.274ms	88	6.491ms	152	25.39ms		
25	0.301ms	89	6.677ms	153	25.81ms		
26	0.330ms	90	6.865ms	154	26.23ms		
27	0.360ms	91	7.057ms	155	26.66ms		
28	0.393ms	92	7.252ms	156	27.09ms		
29	0.426ms	93	7.450ms	157	27.53ms		
30	0.462ms	94	7.651ms	158	27.97ms		
31	0.500ms	95	7.855ms	159	28.41ms		
32	0.539ms	96	8.063ms	160	28.86ms		
33	0.580ms	97	8.274ms	161	29.31ms		
34	0.623ms	98	8.489ms	162	29.77ms		
35	0.668ms	99	8.706ms	163	30.23ms		
36	0.716ms	100	8.927ms	164	30.70ms		
37	0.765ms	101	9.151ms	165	31.17ms		
38	0.816ms	102	9.379ms	166	31.64ms		
39	0.869ms	103	9.610ms	167	32.12ms		
40	0.924ms	104	9.844ms	168	32.60ms		
41	0.982ms	105	10.09ms	169	33.09ms		
42	1.041ms	106	10.33ms	170	33.58ms		
43	1.103ms	107	10.57ms	171	34.07ms		
44	1.167ms	108	10.82ms	172	34.57ms		
45	1.233ms	109	11.07ms	173	35.08ms		
46	1.301ms	110	11.33ms	174	35.59ms		
47	1.372ms	111	11.59ms	175	36.10ms		
48	1.444ms	112	11.85ms	176	36.62ms		
49	1.520ms	113	12.11ms	177	37.14ms		
50	1.597ms	114	12.38ms	178	37.67ms		
51	1.677ms	115	12.66ms	179	38.20ms		
52	1.759ms	116	12.93ms	180	38.73ms		
53	1.844ms	117	13.21ms	181	39.27ms		
54	1.931ms	118	13.50ms	182	39.82ms		
55	2.021ms	119	13.78ms	183	40.36ms		
56	2.113ms	120	14.07ms	184	40.92ms		
57	2.207ms	121	14.37ms	185	41.48ms		
58	2.304ms	122	14.67ms	186	42.04ms		
59	2.404ms	123	14.97ms	187	42.61ms		
60	2.506ms	124	15.27ms	188	43.18ms		
61	2.611ms	125	15.58ms	189	43.75ms		
62	2.718ms	126	15.90ms	190	44.33ms		
63	2.828ms	127	16.21ms	191	44.92ms		

Table #27
VCM Comp Release Time

Data	Value	Data	Value	Data	Value	Data	Value
0	10.88ms	64	65.50ms	128	229.34ms	192	502.40ms
1	10.90ms	65	67.22ms	129	232.76ms	193	507.54ms
2	10.94ms	66	68.96ms	130	236.22ms	194	512.70ms
3	11.00ms	67	70.74ms	131	239.70ms	195	517.88ms
4	11.10ms	68	72.54ms	132	243.20ms	196	523.10ms
5	11.22ms	69	74.36ms	133	246.74ms	197	528.34ms
6	11.36ms	70	76.22ms	134	250.30ms	198	533.60ms
7	11.54ms	71	78.10ms	135	253.88ms	199	538.90ms
8	11.74ms	72	80.00ms	136	257.50ms	200	544.22ms
9	11.96ms	73	81.94ms	137	261.14ms		
10	12.22ms	74	83.90ms	138	264.80ms		
11	12.50ms	75	85.88ms	139	268.50ms		
12	12.80ms	76	87.90ms	140	272.22ms		
13	13.14ms	77	89.94ms	141	275.96ms		
14	13.50ms	78	92.00ms	142	279.74ms		
15	13.88ms	79	94.10ms	143	283.54ms		
16	14.30ms	80	96.22ms	144	287.36ms		
17	14.74ms	81	98.36ms	145	291.22ms		
18	15.20ms	82	100.54ms	146	295.10ms		
19	15.70ms	83	102.74ms	147	299.00ms		
20	16.22ms	84	104.96ms	148	302.94ms		
21	16.76ms	85	107.22ms	149	306.90ms		
22	17.34ms	86	109.50ms	150	310.88ms		
23	17.94ms	87	111.80ms	151	314.90ms		
24	18.56ms	88	114.14ms	152	318.94ms		
25	19.22ms	89	116.50ms	153	323.00ms		
26	19.90ms	90	118.88ms	154	327.10ms		
27	20.60ms	91	121.30ms	155	331.22ms		
28	21.34ms	92	123.74ms	156	335.36ms		
29	22.10ms	93	126.20ms	157	339.54ms		
30	22.88ms	94	128.70ms	158	343.74ms		
31	23.70ms	95	131.22ms	159	347.96ms		
32	24.54ms	96	133.76ms	160	352.22ms		
33	25.40ms	97	136.34ms	161	356.50ms		
34	26.30ms	98	138.94ms	162	360.80ms		
35	27.22ms	99	141.56ms	163	365.14ms		
36	28.16ms	100	144.22ms	164	369.50ms		
37	29.14ms	101	146.90ms	165	373.88ms		
38	30.14ms	102	149.60ms	166	378.30ms		
39	31.16ms	103	152.34ms	167	382.74ms		
40	32.22ms	104	155.10ms	168	387.20ms		
41	33.30ms	105	157.88ms	169	391.70ms		
42	34.40ms	106	160.70ms	170	396.22ms		
43	35.54ms	107	163.54ms	171	400.76ms		
44	36.70ms	108	166.40ms	172	405.34ms		
45	37.88ms	109	169.30ms	173	409.94ms		
46	39.10ms	110	172.22ms	174	414.56ms		
47	40.34ms	111	175.16ms	175	419.22ms		
48	41.60ms	112	178.14ms	176	423.90ms		
49	42.90ms	113	181.14ms	177	428.60ms		
50	44.22ms	114	184.16ms	178	433.34ms		
51	45.56ms	115	187.22ms	179	438.10ms		
52	46.94ms	116	190.30ms	180	442.88ms		
53	48.34ms	117	193.40ms	181	447.70ms		
54	49.76ms	118	196.54ms	182	452.54ms		
55	51.22ms	119	199.70ms	183	457.40ms		
56	52.70ms	120	202.88ms	184	462.30ms		
57	54.20ms	121	206.10ms	185	467.22ms		
58	55.74ms	122	209.34ms	186	472.16ms		
59	57.30ms	123	212.60ms	187	477.14ms		
60	58.88ms	124	215.90ms	188	482.14ms		
61	60.50ms	125	219.22ms	189	487.16ms		
62	62.14ms	126	222.56ms	190	492.22ms		
63	63.80ms	127	225.94ms	191	497.30ms		

Table #28
VCM EQ Frequency

Data	Value	Data	Value	Data	Value
0	16.0Hz	64	630Hz	128	25.0kHz
1	17.0Hz	65	670Hz	129	26.5kHz
2	18.0Hz	66	710Hz	130	28.0kHz
3	19.0Hz	67	750Hz	131	30.0kHz
4	20.0Hz	68	800Hz	132	31.5kHz
5	21.2Hz	69	850Hz	133	33.5kHz
6	22.4Hz	70	900Hz	134	35.5kHz
7	23.6Hz	71	950Hz	135	37.5kHz
8	25.0Hz	72	1.00kHz	136	40.0kHz
9	26.5Hz	73	1.06kHz		
10	28.0Hz	74	1.12kHz		
11	30.0Hz	75	1.18kHz		
12	31.5Hz	76	1.25kHz		
13	33.5Hz	77	1.32kHz		
14	35.5Hz	78	1.40kHz		
15	37.5Hz	79	1.50kHz		
16	40.0Hz	80	1.60kHz		
17	42.5Hz	81	1.70kHz		
18	45.0Hz	82	1.80kHz		
19	47.5Hz	83	1.90kHz		
20	50.0Hz	84	2.00kHz		
21	53.0Hz	85	2.12kHz		
22	56.0Hz	86	2.24kHz		
23	60.0Hz	87	2.36kHz		
24	63.0Hz	88	2.50kHz		
25	67.0Hz	89	2.65kHz		
26	71.0Hz	90	2.80kHz		
27	75.0Hz	91	3.00kHz		
28	80.0Hz	92	3.15kHz		
29	85.0Hz	93	3.35kHz		
30	90.0Hz	94	3.55kHz		
31	95.0Hz	95	3.75kHz		
32	100Hz	96	4.00kHz		
33	106Hz	97	4.25kHz		
34	112Hz	98	4.50kHz		
35	118Hz	99	4.75kHz		
36	125Hz	100	5.00kHz		
37	132Hz	101	5.30kHz		
38	140Hz	102	5.60kHz		
39	150Hz	103	6.00kHz		
40	160Hz	104	6.30kHz		
41	170Hz	105	6.70kHz		
42	180Hz	106	7.10kHz		
43	190Hz	107	7.50kHz		
44	200Hz	108	8.00kHz		
45	212Hz	109	8.50kHz		
46	224Hz	110	9.00kHz		
47	236Hz	111	9.50kHz		
48	250Hz	112	10.0kHz		
49	265Hz	113	10.6kHz		
50	280Hz	114	11.2kHz		
51	300Hz	115	11.8kHz		
52	315Hz	116	12.5kHz		
53	335Hz	117	13.2kHz		
54	355Hz	118	14.0kHz		
55	375Hz	119	15.0kHz		
56	400Hz	120	16.0kHz		
57	425Hz	121	17.0kHz		
58	450Hz	122	18.0kHz		
59	475Hz	123	19.0kHz		
60	500Hz	124	20.0kHz		
61	530Hz	125	21.2kHz		
62	560Hz	126	22.4kHz		
63	600Hz	127	23.6kHz		

Table #29
VCM EQ Q

Data	Value
0	0.50
1	0.53
2	0.56
3	0.59
4	0.63
5	0.67
6	0.71
7	0.75
8	0.79
9	0.84
10	0.89
11	0.94
12	1.00
13	1.06
14	1.12
15	1.19
16	1.26
17	1.33
18	1.41
19	1.50
20	1.59
21	1.68
22	1.78
23	1.89
24	2.00
25	2.12
26	2.24
27	2.38
28	2.52
29	2.67
30	2.83
31	3.00
32	3.17
33	3.36
34	3.56
35	3.78
36	4.00
37	4.24
38	4.49
39	4.76
40	5.04
41	5.34
42	5.66
43	5.99
44	6.35
45	6.73
46	7.13
47	7.55
48	8.00
49	8.48
50	8.98
51	9.51
52	10.08
53	10.68
54	11.31
55	11.99
56	12.70
57	13.45
58	14.25
59	15.10
60	16.00

Mixing Template List

No.	Name
1	Contemporary R&B
2	Flip Hop
3	Hip Hop 1
4	Hip Hop 2
5	Disco
6	Funk 1
7	Funk 2
8	70's Rock
9	Soft Rock
10	Unplugged
11	Piano Club
12	Cool Funk
13	Analog Pop
14	Guitar Pop
15	Slowfeel
16	Combo Jazz
17	Samba
18	Salsa
19	Montuno
20	Reggae
21	Trance
22	Ibiza Trance
23	Dream Dance
24	Synth Pop
25	Chill Out
26	Club House
27	Latin House
28	Garage
29	Retro Pop
30	Xover Rock
31	Spanish Pop
32	Turkish Pop

Remote Control Assignments

DAW

Cubase	Cubase 7 series
Logic	Logic Pro 9
SONAR	SONAR X2
Digital Performer	Digital Performer 7

Remote Control Function

	Cubase	Logic	SONAR	Digital Performer
BANK SELECT [DEC]/[INC]	Changes the Control Template	←	←	←
Knob Function 1	Changes the functions assigned to Knobs 1 – 4.	←	←	←
Knob Function 2	Changes the functions assigned to Knobs 5 – 8.	—	—	—
SEQ TRANSPORT Top	Returns to the beginning of the song	←	←	←
SEQ TRANSPORT Rewind	Rewinds through the song	←	←	←
SEQ TRANSPORT Forward	Fast-forwards through the song	←	←	←
SEQ TRANSPORT Stop	Stops recording or playback	←	←	←
SEQ TRANSPORT Play	Starts playback from the current point	←	←	←
SEQ TRANSPORT Rec	Starts song recording	←	←	←
[F1]	Opens/closes the [Add Instrument Track] dialog.	Mackie Control F1	Mackie Control F1	—
[F2]	Opens/closes the VSTi display for the selected Track.	Mackie Control F2	Mackie Control F2	—
[F3]	Opens/closes the settings window for the channel of the selected Track.	Mackie Control F3	Mackie Control F3	—
[F4]	Switches Automation Read for the selected Track on or off.	Mackie Control F4	Mackie Control F4	—
[F5]	Switches Automation Write for the selected Track on or off.	Mackie Control F5	Mackie Control F5	—
[F6]	Delete	Mackie Control F6	Mackie Control F6	—
[SF1] – [SF6]	Assignable functions	Mackie Control F7 – F12	Mackie Control F7 – F12	—
MUTE	Turns Mute on or off for the selected track	—	—	—
SOLO	Turns Solo on or off for the selected track	—	—	—
EXIT	Escape key on computer keyboard	←	←	←
ENTER	Enter key on computer keyboard	←	←	←
Cursor button	Cursor key on computer keyboard	←	←	←
[INC]/[DEC]	Changes the Program	←	←	←
Number [1] – [10]	Numeric keys on computer keyboard	←	←	←
Number [14] – [16]	“.” (period), “-” (minus), “+” (plus) on computer keyboard	←	←	←
[DATA] dial	Operates the parameter specified via the mouse pointer (when the [JOG]/[LOCK] button is set to off). Functions as AI KNOB (when the [JOG]/[LOCK] button is set to on).	—	—	—
[UTILITY]	Calls up the display for the Utility settings dedicated to the Remote mode	←	←	←
[A] – [F]	Changes Memory 1 – 6, which are assigned to the [SF1] – [SF6] buttons in the MOXF6/MOXF8 Extension Setup window.	—	—	—

Control List

Controller Set Destination

No.	Parameter		Voice	Drum
0	off	Common	O	O
1	Insertion Effect A Parameter 1	:	O	O
	:			
16	Insertion Effect A Parameter 16	:	O	O
17	Insertion Effect B Parameter 1	:	O	O
	:			
32	Insertion Effect B Parameter 16	:	O	O
33	Insertion Effect L Parameter 1	:	O	-
	:			
64	Insertion Effect L Parameter 32	:	O	-
65	Volume	:	O	O
66	Reverb Send	:	O	O
67	Chorus Send	:	O	O
68	Common LFO Speed	:	O	-
69	Common LFO Depth 1	:	O	-
70	Common LFO Depth 2	:	O	-
71	Common LFO Depth 3	:	O	-
72	Portamento Time	:	O	-
73	Element Level	Element	O	-
74	Element Pan	:	O	-
75	Key On Delay Time	:	O	-
76	Element LFO Speed	:	O	-
77	Element LFO PMD	:	O	-
78	Element LFO AMD	:	O	-
79	Element LFO FMD	:	O	-
80	Coarse Tune	:	O	-
81	Fine Tune	:	O	-
82	PEG Depth	:	O	-
83	PEG Hold Time	:	O	-
84	PEG Attack Time	:	O	-
85	PEG Decay 1 Time	:	O	-
86	PEG Decay 2 Time	:	O	-
87	PEG Release Time	:	O	-
88	AEG Attack Time	:	O	-
89	AEG Decay 1 Time	:	O	-
90	AEG Decay 2 Time	:	O	-
91	AEG Release Time	:	O	-
92	FEG Depth	:	O	-
93	FEG Hold Time	:	O	-
94	FEG Attack Time	:	O	-
95	FEG Decay 1 Time	:	O	-
96	FEG Decay 2 Time	:	O	-
97	FEG Release Time	:	O	-
98	Cutoff Frequency	:	O	-
99	Resonance	:	O	-
100	HPF Cutoff Frequency	:	O	-
101	Mono/Poly	Common	O	-

LFO Box Destination

No.	Parameter	
0	Insertion Effect A Parameter 1	Common
	:	
15	Insertion Effect A Parameter 16	:
16	Insertion Effect B Parameter 1	:
	:	
31	Insertion Effect B Parameter 16	:
32	Insertion Effect L Parameter 1	:
	:	
63	Insertion Effect L Parameter 32	:
64	Amplitude Modulation	Element
65	Pitch Modulation	:
66	Filter Modulation	:
67	Resonance	:
68	Element Pan	:
69	Element LFO Speed	:

MIDI Data Format

Many MIDI messages listed in the MIDI Data Format section are expressed in hexadecimal or binary numbers. Hexadecimal numbers may include the letter "H" as a suffix. The letter "n" indicates a certain whole number. The chart below lists the corresponding decimal number for each hexadecimal number.

Decimal	Hexadecimal	Decimal	Hexadecimal
0	0	64	40
1	1	65	41
2	2	66	42
3	3	67	43
4	4	68	44
5	5	69	45
6	6	70	46
7	7	71	47
8	8	72	48
9	9	73	49
10	0A	74	4A
11	0B	75	4B
12	0C	76	4C
13	0D	77	4D
14	0E	78	4E
15	0F	79	4F
16	10	80	50
17	11	81	51
18	12	82	52
19	13	83	53
20	14	84	54
21	15	85	55
22	16	86	56
23	17	87	57
24	18	88	58
25	19	89	59
26	1A	90	5A
27	1B	91	5B
28	1C	92	5C
29	1D	93	5D
30	1E	94	5E
31	1F	95	5F
32	20	96	60
33	21	97	61
34	22	98	62
35	23	99	63
36	24	100	64
37	25	101	65
38	26	102	66
39	27	103	67
40	28	104	68
41	29	105	69
42	2A	106	6A
43	2B	107	6B
44	2C	108	6C
45	2D	109	6D
46	2E	110	6E
47	2F	111	6F
48	30	112	70
49	31	113	71
50	32	114	72
51	33	115	73
52	34	116	74
53	35	117	75
54	36	118	76
55	37	119	77
56	38	120	78
57	39	121	79
58	3A	122	7A
59	3B	123	7B
60	3C	124	7C
61	3D	125	7D
62	3E	126	7E
63	3F	127	7F

Additional Notes

- For example, 144 – 159(Decimal)/9nH/1001 0000 – 1001 1111(Binary) indicate the note-on messages for the channels 1 through 16 respectively. 176 – 191/BnH/1011 0000 – 1011 1111 indicate the control change messages for the channels 1 through 16 respectively. 192 – 207/CnH/1100 0000 – 1100 1111 indicate the program change messages for the channels 1 through 16 respectively. 240/F0H/1111 0000 is positioned at the beginning of data to indicate a system exclusive message. 247/F7H/1111 0111 is positioned at the end of the system exclusive message.
- aaH (Hexadecimal)/0aaaaaaa (Binary) indicates the data addresses. The data address consists of High, Mid and Low.
- bbH/0bbbbbbb indicates byte counts.
- ccH/0ccccccc indicates check sums.
- ddH/0ddddddd indicates data/value.

SYNTHESIZER/SEQUENCER PART

(1) TRANSMIT FLOW

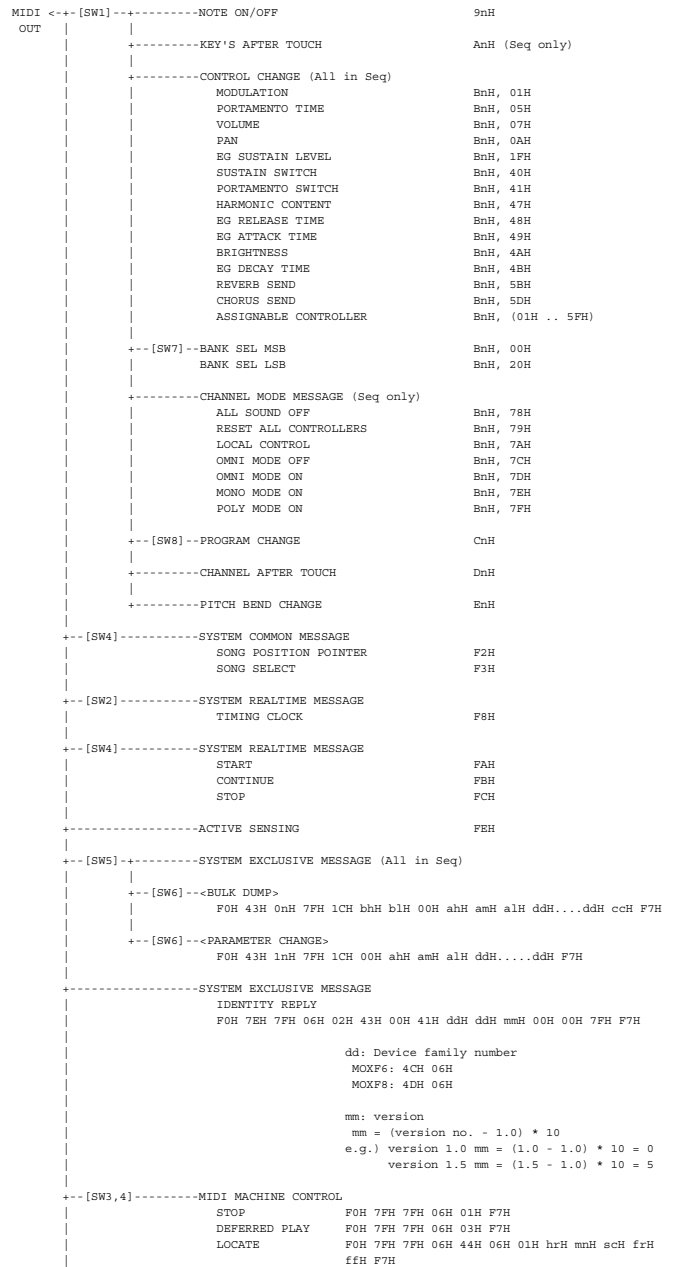

- [SW1] MIDI Transmit Channel
In the Master mode: complies with Zone Transmit Channel.
In the mode other than the Master: complies with Keyboard Transmit Channel.
The sequence data played back in the Song/Pattern mode is transmitted according to the MIDI Filter settings.
- [SW2] SYSTEM MIDI Clock Out
- [SW3] SYSTEM MIDI Sync (transmitted when the MIDI Sync is set to MTC.)
- [SW4] SYSTEM Sequencer Control
- [SW5] SYSTEM MIDI Device Number
When set to all, transmitted via 1.
The sequence data played back in the Song/Pattern mode is transmitted according to the MIDI Filter settings.
- [SW6] The Edit Buffer data (just currently edited data) will be transmitted/received only in the corresponding Mode.
The other types of data such as Utility settings can be transmitted/received in any mode.
- [SW7] SYSTEM Bank Select Switch
- [SW8] SYSTEM Program Change Switch

(2) RECEIVE FLOW

MIDI>--	[SW1]	-----NOTE OFF	8nH
		-----NOTE ON/OFF	9nH
		-----KEY'S AFTER TOUCH	AnH (Seq only)
		-----CONTROL CHANGE (All in Seq)	
		MODULATION	BnH, 01H
		PORTAMENTO TIME	BnH, 05H
		DATA ENTRY MSB	BnH, 06H
		DATA ENTRY LSB	BnH, 26H
		MAIN VOLUME	BnH, 07H
		PAN	BnH, 0AH
		EXPRESSION	BnH, 0BH
		EG SUSTAIN LEVEL	BnH, 1FH
		SUSTAIN SWITCH	BnH, 40H
		PORTAMENTO SWITCH	BnH, 41H
		SOSTENUTO	BnH, 42H
		HARMONIC CONTENT	BnH, 47H
		EG RELEASE TIME	BnH, 48H
		EG ATTACK TIME	BnH, 49H
		BRIGHTNESS	BnH, 4AH
		EG DECAY TIME	BnH, 4BH
		EFFECT1 DEPTH	BnH, 5BH
		EFFECT3 DEPTH	BnH, 5DH
		DATA ENTRY INC	BnH, 60H
		DATA ENTRY DEC	BnH, 61H
		ASSIGNABLE CONTROLLER	BnH, (00H .. 5FH)
		RPN	
		PITCH BEND SENS.	BnH, 64H, 00H, 65H, 00H, 06H, mmH
		FINE TUNING	BnH, 64H, 01H, 65H, 00H, 06H, mmH, 26H, 11H
		COARSE TUNING	BnH, 64H, 02H, 65H, 00H, 06H, mmH
		RPN RESET	BnH, 64H, 7FH, 65H, 7FH
	[SW7]	--BANK SEL MSB	BnH, 00H
		BANK SEL LSB	BnH, 20H
		-----CHANNEL MODE MESSAGE	
		ALL SOUND OFF	BnH, 78H
		RESET ALL CONTROLLERS	BnH, 79H
		ALL NOTE OFF	BnH, 7BH
		OMNI MODE OFF	BnH, 7CH
		OMNI MODE ON	BnH, 7DH
		MONO MODE ON	BnH, 7EH
		POLY MODE ON	BnH, 7FH
	[SW8]	--PROGRAM CHANGE	CnH
		-----CHANNEL AFTER TOUCH	DnH
		-----PITCH BEND CHANGE	EnH
	[SW3]	-----SYSTEM COMMON MESSAGE	
		MTC QUARTER FRAME MESSAGE	F1H
	[SW4]	-----SYSTEM COMMON MESSAGE	
		SONG POSITION POINTER	F2H
		SONG SELECT	F3H
	[SW3]	-----SYSTEM REALTIME MESSAGE	
		TIMING CLOCK	F8H
	[SW4]	-----SYSTEM REALTIME MESSAGE	
		START	FAH
		CONTINUE	FBH
		STOP	FCH
		-----ACTIVE SENSING	FEH
	[SW5]	-----SYSTEM EXCLUSIVE MESSAGE(All in Seq)	
		MIDI MASTER VOLUME	FOH 7FH 7FH 04H 01H 11H mmH F7H
	[SW9]	--<BULK DUMP>	FOH 43H 0nH 7FH 1CH bhH blH 00H ahH amH alH ddH....dH cH F7H
	[SW6]	--<PARAMETER CHANGE>	FOH 43H 1nH 7FH 1CH 00H ahH amH alH ddH....dH F7H
	[SW9]	--<BULK DUMP REQUEST>	FOH 43H 2nH 7FH 1CH 00H ahH amH alH ddH....dH F7H
	[SW6]	--<PARAMETER REQUEST>	FOH 43H 3nH 7FH 1CH 00H ahH amH alH F7H
	[SW2]	--GM MODE ON	FOH 7EH 7FH 09H 01H F7H
		-----SYSTEM EXCLUSIVE MESSAGE	
		IDENTITY REQUEST	FOH 7EH 0nH 06H 01H F7H
		SECTION CONTROL	FOH 43H 7EH 00H saH ddH F7H (Pattern Mode only)

- [SW1] In the Voice mode: complies with Basic Receive Channel
In the Performance mode: complies with Basic Receive Channel and Part Receive Switch
In the Song/Pattern mode: complies with Part Receive Channel and Part Receive Switch.
The sequence data recorded to the Song/Pattern is recognized according to the MIDI Filter settings.
- [SW2] Recognized only in the Song/Pattern mode.
- [SW3] SYSTEM MIDI Sync (can be set to "internal," "MIDI," or "MTC")
- [SW4] SYSTEM Sequencer Control
- [SW5] SYSTEM MIDI Device Number
When this is not set to off, the MIDI Master Volume can be recognized in any mode.
The sequence data recorded to the Song/Pattern is recognized according to the MIDI Filter settings.
- [SW6] The System data can be transmitted/recognized in any mode.
- [SW7] SYSTEM Bank Select Switch
- [SW8] SYSTEM Program Change Switch
- [SW9] SYSTEM Bulk Protect and same as SW6.

(3) TRANSMIT/RECEIVE DATA

(3-1) CHANNEL VOICE MESSAGES

(3-1-1) NOTE OFF

STATUS	100nmmn (8nH)	n = 0 - 15 CHANNEL NUMBER
NOTE No.	0kkkkkkk	k = 0 (C-2) - 127 (G8)
VELOCITY	0vvvvvvv	v: ignored
Receive only		

(3-1-2) NOTE ON/OFF

STATUS	1001nnnn (9nH)	n = 0 - 15 CHANNEL NUMBER
NOTE NUMBER	0kkkkkkk	k = 0 (C-2) - 127 (G8)
VELOCITY NOTE ON	0vvvvvvv (v≠0)	
VELOCITY NOTE OFF	0vvvvvvv (v=0)	

(3-1-3) CONTROL CHANGE

STATUS	1011nnnn (BnH)	n = 0 - 15 CHANNEL NUMBER
CONTROL NUMBER	0ccccccc	
CONTROL VALUE	0vvvvvvv	

*TRANSMITTED CONTROL NUMBER

c = 0	BANK SELECT MSB	; v = 0 - 127	*3
c = 32	BANK SELECT LSB	; v = 0 - 127	*3
c = 1	MODULATION	; v = 0 - 127	
c = 5	PORTAMENTO TIME	; v = 0 - 127	*2
c = 7	MAIN VOLUME	; v = 0 - 127	
c = 10	PAN	; v = 0 - 127	
c = 31	EG SUSTAIN LEVEL	; v = 0: -64 - 64: 0 - 127: +63	*6
c = 64	SUSTAIN SWITCH	; v = 0 - 127	*2
c = 65	PORTAMENTO SWITCH	; v = 0 - 63: OFF, 64 - 127: ON	
c = 71	HARMONIC CONTENT	; v = 0: - 64 - 64: 0 - 127: +63	
c = 72	EG RELEASE TIME	; v = 0: - 64 - 64: 0 - 127: +63	
c = 73	EG ATTACK TIME	; v = 0: - 64 - 64: 0 - 127: +63	
c = 74	BRIGHTNESS	; v = 0: - 64 - 64: 0 - 127: +63	
c = 75	EG DECAY TIME	; v = 0: - 64 - 64: 0 - 127: +63	
c = 91	REVERB SEND	; v = 0 - 127	
c = 93	CHORUS SEND	; v = 0 - 127	
c = 1..95	ASSIGNABLE CONTROLLER	; v = 0 - 127	*4

The Sequencer Part will play back all recorded control change messages.

* RECEIVED CONTROL NUMBER

c = 0	BANK SELECT MSB	; v = 0 - 127	*3
c = 32	BANK SELECT LSB	; v = 0 - 127	*3
c = 1	MODULATION	; v = 0 - 127	
c = 5	PORTAMENTO TIME	; v = 0 - 127	*2
c = 6	DATA ENTRY MSB	; v = 0 - 127	*1
c = 38	DATA ENTRY LSB	; v = 0 - 127	*1
c = 7	MAIN VOLUME	; v = 0 - 127	
c = 10	PAN	; v = 0 - 127	
c = 11	EXPRESSION	; v = 0 - 127	
c = 31	EG SUSTAIN LEVEL	; v = 0: - 64 - 64: 0 - 127: +63	*2
c = 64	SUSTAIN SWITCH	; v = 0 - 127	
c = 65	PORTAMENTO SWITCH	; v = 0 - 63: OFF, 64 - 127: ON	*2
c = 66	SOSTENUTO	; v = 0 - 63: OFF, 64 - 127: ON	
c = 71	HARMONIC CONTENT	; v = 0: -64 - 64: 0 - 127: +63	
c = 72	EG RELEASE TIME	; v = 0: -64 - 64: 0 - 127: +63	*2
c = 73	EG ATTACK TIME	; v = 0: -64 - 64: 0 - 127: +63	
c = 74	BRIGHTNESS	; v = 0: -64 - 64: 0 - 127: +63	
c = 75	EG DECAY TIME	; v = 0: -64 - 64: 0 - 127: +63	
c = 91	EFFECT1 DEPTH	; v = 0 - 127	
c = 93	EFFECT3 DEPTH	; v = 0 - 127	
c = 96	DATA ENTRY INC	; v = 127	*1
c = 97	DATA ENTRY DEC	; v = 127	*1
c = 1..95	ASSIGNABLE CONTROLLER	; v = 0 - 127	*4

All Control Change events can be recorded to the Song/Pattern.

*1 Used only when a value is set using RPN.
*2 Invalid with Drum Voices.
*3 Relation between BANK SELECT and PROGRAM is as follows:

CATEGORY	MSB	LSB	PROGRAM No.	
GM Voice	0	0	0..127 (1..128)	
GM Drum Voice	127	0	0 (1)	
Normal Voice Preset 1	63	0	0..127 (1..128)	
Preset 2	63	1	0..127 (1..128)	
Preset 3	63	2	0..127 (1..128)	
Preset 4	63	3	0..127 (1..128)	
Preset 5	63	4	0..127 (1..128)	
Preset 6	63	5	0..127 (1..128)	
Preset 7	63	6	0..127 (1..128)	
Preset 8	63	7	0..127 (1..128)	
Preset 9	63	8	0..127 (1..128)	
User 1	63	9	0..127 (1..128)	
User 2	63	10	0..127 (1..128)	
User 3	63	11	0..127 (1..128)	
Drum Voice Preset	63	32	0..71 (1..72)	
User	63	40	0..31 (1..32)	
Mixing Voice	63	60	0..15 (1..16)	*5
Performance User 1	63	64	0..127 (1..128)	
User 2	63	65	0..127 (1..128)	

*4 The default CONTROL NUMBERS of ASSIGNABLE CONTROLLER are as follows:
BREATH CONTROLLER 2
FOOT CONTROLLER 2 4
FOOT CONTROLLER 1 11
ASSIGN 1 16
ASSIGN 2 17
RIBBON CONTROLLER 22
ASSIGNABLE FUNCTION 1 86
ASSIGNABLE FUNCTION 2 87
FOOT SWITCH 88

*5 Can be selected only in the Song/Pattern mode. Up to 16 Mixing Voices are available in a Song/Pattern.
*6 When the sustain pedal is set to something other than "FC3 (Half On)," operating the sustain pedal transmits only values of 0 (off) or 127 (on).

PORTAMENTO TIME sets the time it takes for the pitch to reach the next note played when PORTAMENTO SWITCH is set to on.
 PAN position relatively changes according to the preset value for each voice.
 EFFECT1 DEPTH controls reverb send level.
 EFFECT3 DEPTH controls chorus send level.
 HARMONIC CONTENT adjusts the resonance preset for each voice. Setting a value adds to or subtracts from the center value, 64, since it is an offset parameter.
 The larger the value more resonant sound will be produced.
 The effective range may be narrower than the range you can designate depending on the selected voice.
 The parameters, EG ATTACK TIME, EG DECAY TIME, EG SUSTAIN LEVEL, EG RELEASE TIME adjust the envelopes preset for each voice. Setting these values add to or subtract from the center value, 64, since these are offset parameters.
 BRIGHTNESS adjusts the cutoff frequency preset for each voice. Setting a value adds to or subtracts from the center value, 64, since it is an offset parameter. The smaller the value the cutoff frequency will be lowered. The effective range may be narrower than the range you can designate depending on the selected voice.
 Bank Select will be actually executed when the Program Change message is received. Bank Select and Program Change numbers that are not supported by Yamaha will be ignored.

(3-1-4) PROGRAM CHANGE

STATUS	1100nnnn (CnH)	n = 0 - 15 CHANNEL NUMBER
PROGRAM NUMBER	0ppppppp	p = 0 - 127

(3-1-5) CHANNEL AFTER TOUCH

STATUS	1101nnnn (DnH)	n = 0 - 15 CHANNEL NUMBER
VALUE	0vvvvvvv	v = 0 - 127 AFTER TOUCH VALUE

(3-1-6) PITCH BEND CHANGE

STATUS	1110nnnn (EnH)	n = 0 - 15 CHANNEL NUMBER
LSB	0vvvvvvv	PITCH BEND CHANGE LSB
MSB	0vvvvvvv	PITCH BEND CHANGE MSB

Transmitted with a resolution of 7 bits.

(3-2) CHANNEL MODE MESSAGES

STATUS	1011nnnn (BnH)	n = 0 - 15 CHANNEL NUMBER
CONTROL NUMBER	0ccccccc	c = CONTROL NUMBER
CONTROL VALUE	0vvvvvvv	v = DATA VALUE

(3-2-1) ALL SOUND OFF (CONTROL NUMBER = 78H, DATA VALUE = 0)

All the sounds currently played including the channel messages such as note-on and hold-on in a certain channel are muted when receiving this message.

(3-2-2) RESET ALL CONTROLLERS (CONTROL NUMBER = 79H, DATA VALUE = 0)

Resets the values set for the following controllers.

PITCH BEND CHANGE	0 (center)
CHANNEL AFTER TOUCH	0 (minimum)
MODULATION	0 (minimum)
EXPRESSION	127 (maximum)
BREATH CONTROLLER	127 (maximum)
FOOT CONTROLLER 1	127 (maximum)
FOOT CONTROLLER 2	127 (maximum)
FOOT SWITCH	0 (off)
ASSIGN 1	0 (center)
ASSIGN 2	0 (center)
RIBBON CONTROLLER	0 (center)
ASSIGNABLE FUNCTION 1	0 (off)
ASSIGNABLE FUNCTION 2	0 (off)
SUSTAIN SWITCH	0 (off)
SOSTENUTO SWITCH	0 (off)
RPN	Not assigned; No change

Doesn't reset the following data:

PROGRAM CHANGE, BANK SELECT MSB/LSB, VOLUME, PAN, HARMONIC CONTENT, SUSTAIN LEVEL, RELEASE TIME, ATTACK TIME, DECAY TIME, BRIGHTNESS, EFFECT1 DEPTH, EFFECT3 DEPTH, PORTAMENTO SWITCH, PITCH BEND SENSITIVITY, FINE TUNING, COARSE TUNING

(3-2-3) ALL NOTE OFF (CONTROL NUMBER = 7BH, DATA VALUE = 0)

All the notes currently set to on in certain channel(s) are muted when receiving this message. However, if Sustain or Sostenuto is on, notes will continue sounding until these are turned off.

(3-2-4) OMNI MODE OFF (CONTROL NUMBER = 7CH, DATA VALUE = 0)

Performs the same function as when receiving ALL NOTES OFF.
 Sets VOICE RECEIVE CHANNEL to "OMNI OFF" channel 1.

(3-2-5) OMNI MODE ON (CONTROL NUMBER = 7DH, DATA VALUE = 0)

Performs the same function as when receiving ALL NOTES OFF.
 Sets VOICE RECEIVE CHANNEL to "OMNI ON."

(3-2-6) MONO (CONTROL NUMBER = 7EH, DATA VALUE = 0..16)

Performs the same function as when receiving ALL SOUNDS OFF. If the 3rd byte (mono) is within 0 through 16, the channel will be Mode 4 (m = 1).
 In the Voice mode, the mode can be Mode 2 (m = 1) according to VOICE RECEIVE CHANNEL.

(3-2-7) POLY (CONTROL NUMBER = 7FH, DATA VALUE = 0)

Performs the same function as when receiving ALL SOUNDS OFF. The channel will be Mode 3.
 In the Voice mode, the mode can be Mode 1 according to VOICE RECEIVE CHANNEL.

(3-3) REGISTERED PARAMETER NUMBER

STATUS	1011nnnn (BnH)	n = 0 - 15 CHANNEL NUMBER
LSB	01100100 (64H)	
RPN LSB	0ppppppp	p = RPN LSB (Refer to the table as shown below.)
MSB	01100101 (65H)	
RPN MSB	0qqqqqqq	q = RPN MSB (Refer to the table as shown below.)
DATA ENTRY MSB	00000110 (06H)	
DATA VALUE	0mmmmmmm	m = Data Value
DATA ENTRY LSB	00100110 (26H)	
DATA VALUE	01111111	l = Data Value

First, designate the parameter using RPN MSB/LSB numbers. Then, set its value with data entry MSB/LSB.

RPN	D. ENTRY	DATA RANGE
LSB MSB MSB LSB	PARAMETER NAME	DATA RANGE
00H 00H mmH ---	PITCH BEND SENSITIVITY	00H - 18H (0 - 24 semitones)
01H 00H mmH 11H	MASTER FINE TUNE	{mmH, 11H} = {00H, 00H} - {40H, 00H} - {7FH, 7FH}
		(-8192*100/8192) - 0 - (+8191*100/8192)
02H 00H mmH ---	MASTER COARSE TUNE	28H - 40H - 58H (-24 - 0 - +24 semitones)
7FH 7FH --- ---	RPN RESET	

RPN numbers will be left not designated.
 The internal values are not affected.

(3-4) NON-REGISTERED PARAMETER NUMBER

There are no applicable parameters.

(3-5) SYSTEM REAL TIME MESSAGES**(3-5-1) ACTIVE SENSING**

STATUS	11111110 (FEH)
--------	----------------

Transmitted at every 200 msec.

Once this code is received, the instrument starts sensing. When no status nor data is received for over approximately 350 ms, MIDI receiving buffer will be cleared, and the sounds currently played and the Sustain Switch are forcibly turned off. Also, the values of the Controllers are reset to the default settings.

(3-6) SYSTEM EXCLUSIVE MESSAGE**(3-6-1) UNIVERSAL NON REALTIME MESSAGE****(3-6-1-1) GENERAL MIDI MODE ON**

FOH 7EH 7FH 09H 01H F7H

(3-6-1-2) IDENTITY REQUEST (Receive only)

FOH 7EH 0nH 06H 01H F7H

("n" = Device No. However, this instrument receives under "omni.")

(3-6-1-3) IDENTITY REPLY (Transmit only)

FOH 7EH 7FH 06H 02H 43H 00H 41H ddH ddH mmH 00H 00H 7FH F7H

dd: Device family number

MOXF6: 4CH 06H

MOXF8: 4DH 06H

mm: version

mm = (version no. - 1.0) * 10

e.g.) version 1.0 mm = (1.0 - 1.0) * 10 = 0

version 1.5 mm = (1.5 - 1.0) * 10 = 5

(3-6-2) UNIVERSAL REALTIME MESSAGE**(3-6-2-1) MIDI MASTER VOLUME**

FOH 7FH 7FH 04H 01H 11H mmH F7H

Sets the MASTER VOLUME value.

The value "mm" is used to set the master volume (the value "l" should be ignored).

(3-6-3) PARAMETER CHANGE**(3-6-3-1) NATIVE PARAMETER CHANGE, MODE CHANGE**

11110000	F0	Exclusive status
01000011	43	YAMAHA ID
0001nnnn	1n	device Number
01111111	7F	Group Number High
00011100	1C	Group Number Low
00000000	00	Model ID
0aaaaaaa	aaaaaaa	Address High
0aaaaaaa	aaaaaaa	Address Mid
0aaaaaaa	aaaaaaa	Address Low
0ddddd	ddddd	Data
11110111	F7	End of Exclusive

For parameters with data size of 2 or more, the appropriate number of data bytes will be transmitted.

(3-6-4) BULK DUMP

11110000	F0	Exclusive status
01000011	43	YAMAHA ID
0001nnnn	0n	device Number
01111111	7F	Group Number High
00011100	1C	Group Number Low
0bbbbbbb	bbbbbbb	Byte Count
0bbbbbbb	bbbbbbb	Byte Count
00000000	00	Model ID
0aaaaaaa	aaaaaaa	Address High
0aaaaaaa	aaaaaaa	Address Mid
0aaaaaaa	aaaaaaa	Address Low
0	0	Data
0ccccccc	ccccccc	Check-sum
11110111	F7	End of Exclusive

The Check sum is the value that results in a value of 0 for the lower 7 bits when the Model ID, Start Address, Data and Check sum itself are added.

(3-6-5) DUMP REQUEST

11110000	F0	Exclusive status
01000011	43	YAMAHA ID
0010nnnn	2n	device Number
01111111	7F	Group Number High
00011100	1C	Group Number Low
00000000	00	Model ID
0aaaaaaa	aaaaaaa	Address High
0aaaaaaa	aaaaaaa	Address Mid
0aaaaaaa	aaaaaaa	Address Low
11110111	F7	End of Exclusive

(3-6-6) PARAMETER REQUEST

11110000	F0	Exclusive status
01000011	43	YAMAHA ID
0011nnnn	3n	device Number
01111111	7F	Group Number High
00011100	1C	Group Number Low
00000000	00	Model ID
0aaaaaaa	aaaaaaa	Address High
0aaaaaaa	aaaaaaa	Address Mid
0aaaaaaa	aaaaaaa	Address Low
11110111	F7	End of Exclusive

(4) SYSTEM OVERVIEW (Keyboard, Sequencer and Tone Generator)

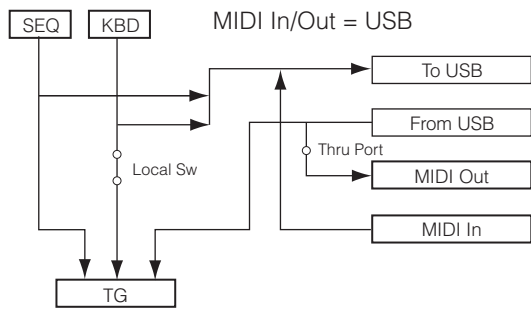
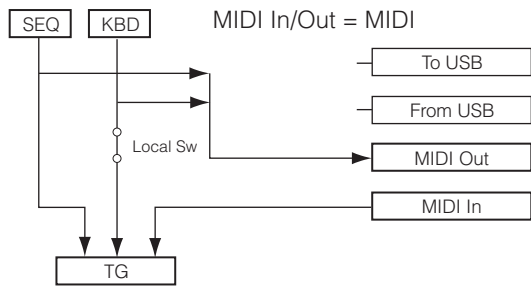

Although three types of note on/note off data, received via MIDI, played by the internal sequencer and played on the keyboard will be distinguished, the other controllers (channel messages) equally affect the entire notes.

ALL SOUND OFF clears all the sounds in the specific channel(s) played by both the keyboard and the data via MIDI.
 ALL NOTES OFF received via MIDI clears the sounds in the specific channel(s) played via MIDI.

MIDI Data Table

Bank Select

Available Bank Select/Program Change

MSB(HEX)	LSB (HEX)	Program No.	Type	Memory	Description			
0	00	0 - 127	Normal Voice	GM Voice				
127	7F	0	Drum Voice	GM Drum				
63	3F	0 - 127	Normal Voice	Preset 1				
		1		01	0 - 127	Preset 2		
		2		02	0 - 127	Preset 3		
		3		03	0 - 127	Preset 4		
		4		04	0 - 127	Preset 5		
		5		05	0 - 127	Preset 6		
		6		06	0 - 127	Preset 7		
		7		07	0 - 127	Preset 8		
		8		08	0 - 127	Preset 9		
		9		09	0 - 127	User 1		
		10		0A	0 - 127	User 2		
		11		0B	0 - 127	User 3		
		32		20	0 - 71	Drum Voice	Preset	
		40		28	0 - 31		User	
63	3F	60	Mixing Voice	User	Can be selected in the Song/Pattern mode.			
		64		40	0 - 127	Performance	User 1	
		65		41	0 - 127		User 2	

When only the Program Change is received after entering any of the mode, the corresponding voice in the currently selected Type/Memory is called up.

The Master number and the Performance/Song/Pattern/Voice mode can be changed only via the Parameter Change.

The Song/Pattern can be changed only via the Song Select (Song: F3, 00 - F3, 3F / Pattern: F3, 00 - F3, 3F).

In the Performance mode, the Part Voice cannot be changed via the Program Change.

Parameter Base Address

Parameter Block	Top Address			Description	
	High	Mid	Low		
	SYSTEM	00	00		00
	00	03	00	Insertion A for Voice A/D	
	00	04	00	Insertion B for Voice A/D	
	00	05	00	Sequencer Setup	
	00	06	00	Remote	
	00	20	00	Master EQ for Voice	
	00	21	00	Master Effect for Voice	
	00	40	00	Audio Part (A/D)	
	00	5n	00	Quick Setup	
	00	6n	00	Quick Setup Config Audio	
	00	7n	00	Quick Setup Config MIDI	
MODE CHANGE	0A	00	00	Mode Change	
PART SET CONTROL for MIX VOICE	0D	00	00	Part Set Control for Mix Voice	
BULK CONTROL	0E	00	00	Header	
	0F	00	00	Footer	
MASTER KEYBOARD	33	00	00	Common	
	32	nn	00	Zone 1 - 4 (nn: 00 - 03)	
PERFORMANCE COMMON	30	00	00	Common	
	30	01	00	Reverb	
	30	02	00	Chorus	
	30	03	00	Insertion A for A/D	
	30	04	00	Insertion B for A/D	
	30	10	00	Master EQ	
	30	11	00	Master Effect	
	30	30	00	Arpeggio Common	
	PERFORMANCE PART	31	pp	00	Part 1 - 4 (pp: 00 - 03)
		34	pp	00	Arpeggio Part 1 - 4 (pp: 00 - 03)
		35	40	00	Audio Part (A/D)
SONG/PATTERN COMMON	36	00	00	Common	
	36	01	00	Reverb	
	36	02	00	Chorus	
	36	03	00	Insertion A for A/D	
	36	04	00	Insertion B for A/D	
	36	10	00	Master EQ	
	36	11	00	Master Effect	
	36	30	00	Arpeggio Common	
	SONG/PATTERN PART	37	pp	00	Part 1 - 16 (pp: 00 - 0F)
38		pp	00	Arpeggio Part 1 - 16 (pp: 00 - 0F)	
39		40	00	Audio Part (A/D)	
NORMAL VOICE COMMON	40	00	00	Common	
	40	01	00	Reverb	
	40	02	00	Chorus	
	40	03	00	Insertion A	
	40	04	00	Insertion B	
	40	05	00	Insertion L	
	40	06	00	Controller+LFO	
	40	30	00	Arpeggio	
NORMAL VOICE ELEMENT GROUP1	41	ee	00	Element Group 1 (ee: 00 - 07)	
NORMAL VOICE ELEMENT GROUP2	42	ee	00	Element Group 2 (ee: 00 - 07)	
DRUM COMMON	46	00	00	Common	
	46	01	00	Reverb	
	46	02	00	Chorus	
	46	03	00	Insertion A	
	46	04	00	Insertion B	
	46	05	00	Insertion L	
	46	08	00	Controller	
	46	30	00	Arpeggio	
DRUM ELEMENT GROUP	47	ee	00	Element Group (ee: 0 - 72)	

Bulk Dump Block

"Top Address" indicates the top address of each block designated by bulk dump operation.
 "Byte Count" indicates the data size contained in each block designated by bulk dump operation.

The Block from the Bulk Header to the Bulk Footer of the Performance and Voice can be received regardless their order. They can be received even if all of them are not transmitted. They cannot be received if the irrelevant Block is included.

To execute 1 Performance/1 Voice bulk dump request, designate its corresponding Bulk Header address.

For the information about "mm" and "nn" shown in the following list, refer to MIDI PARAMETER CHANGE TABLE (BULK CONTROL) below.

Parameter Block	Description	Byte Count		Top Address				
		Dec	Hex	High	Mid	Low		
SYSTEM	System	68	44	00	00	00		
	Insertion A for Voice A/D	36	24	00	03	00		
	Insertion B for Voice A/D	36	24	00	04	00		
	Sequencer Setup	22	16	00	05	00		
	Remote	6	06	00	06	00		
	Master EQ for Voice	20	14	00	20	00		
	Master Effect for Voice	38	26	00	21	00		
	AUDIO IN PART	Audio Part (A/D)	8	08	00	40	00	
	QUICK SETUP	Setup 1	10	0A	00	50	00	
		:				:		
		Setup 6				55		
	QUICK SETUP CONFIG AUDIO	Config 1	16	10	00	60	00	
		:				:		
		Config 6				65		
	QUICK SETUP CONFIG MIDI	Config 1	16	10	00	70	00	
		:				:		
		:				:		
		Config 6				75		
	MASTER KEYBOARD	Bulk Header	0	00	0E	mm	nn	
		COMMON	32	20	33	00	00	
ZONE		Zone 1	16	10	32	00	00	
		:				:		
		Zone 4				03		
Bulk Footer	0	00	0F	mm	nn			
PERFORMANCE	Bulk Header	0	00	0E	mm	nn		
	COMMON	Common	80	50	30	00	00	
		Reverb	38	26	30	01	00	
		Chorus	40	28	30	02	00	
		Insertion A for A/D	36	24	30	03	00	
		Insertion B for A/D	36	24	30	04	00	
		Master EQ	20	14	30	10	00	
		Master Effect	38	26	30	11	00	
		Arpeggio Common	14	0E	30	30	00	
	PART	Part 1	62	3E	31	00	00	
		:				:		
		Part 4				03		
		Arpeggio Part 1	72	48	34	00	00	
		:				:		
	Arpeggio Part 4				03			
	AUDIO IN PART	Audio Part (A/D)	8	08	35	40	00	
	Bulk Footer	0	00	0F	mm	nn		
	SONG/PATTERN	Bulk Header	0	00	0E	mm	nn	
		COMMON	Common	80	50	36	00	00
			Reverb	38	26	36	01	00
Chorus			40	28	36	02	00	
Insertion A for A/D			36	24	36	03	00	
Insertion B for A/D			36	24	36	04	00	
Master EQ			20	14	36	10	00	
Master Effect			38	26	36	11	00	
Arpeggio Common			14	0E	36	30	00	
PART			Part 1	62	3E	37	00	00
			:				:	
		Part 16				0F		
		Arpeggio Part 1	72	48	38	00	00	
		:				:		
		Arpeggio Part 16				0F		
AUDIO IN PART		Audio Part (A/D)	8	08	39	40	00	
Bulk Footer		0	00	0F	mm	nn		

Parameter Block	Description	Byte Count		Top Address			
		Dec	Hex	High	Mid	Low	
VOICE (NORMAL)	Bulk Header	0	00	0E	mm	nn	
	COMMON	Common	80	50	40	00	00
		Reverb	38	26	40	01	00
		Chorus	40	28	40	02	00
		Insertion A	36	24	40	03	00
		Insertion B	36	24	40	04	00
		Insertion L	68	44	40	05	00
		Controller+LFO	60	3C	40	06	00
		Arpeggio	86	56	40	30	00
	ELEMENT	Osc+Amp+Pit Element 1	88	58	41	00	00
		:				:	
		Osc+Amp+Pit Element 8				07	
		Flt+EQ+LFO Element 1	74	4A	42	00	00
		:				:	
	Flt+EQ+LFO Element 8				07		
	Bulk Footer	0	00	0F	mm	nn	
	VOICE (DRUM)	Bulk Header	0	00	0E	mm	nn
		COMMON	Common	72	48	46	00
Reverb			38	26	46	01	00
Chorus			40	28	46	02	00
Insertion A			36	24	46	03	00
Insertion B			36	24	46	04	00
Insertion L			68	44	46	05	00
Controller			24	18	46	08	00
Arpeggio			86	56	46	30	00
KEY		Key C0	46	2E	47	00	00
		:				:	
		Key C6				48	
Bulk Footer		0	00	0F	mm	nn	

MIDI PARAMETER CHANGE TABLE (MODE CHANGE)

Address			Size	Data Range (HEX)	Parameter Name	Description	Default (HEX)	Notes
High	Mid	Low						
0A	00	00	1	00 - 7F	Master Number Select	0 - 127		
		01	1	00 - 04	Mode Change	0: Voice, 1: Performance, 2: Pattern (Multi), 3: Song (Multi), 4: Master		
		03	1		reserved			

TOTAL SIZE = 4 04 (HEX)

MIDI PARAMETER CHANGE TABLE (PART SET CONTROL for MIX VOICE)

Address			Size	Data Range (HEX)	Parameter Name	Description	Default (HEX)	Notes
High	Mid	Low						
0D	00	00	1	00 - 0F	Part Set Control for Mix Voice	0 - 15		

TOTAL SIZE = 1 01 (HEX)

MIDI PARAMETER CHANGE TABLE (BULK CONTROL)

Address			Size	Data Range (HEX)	Parameter Name	Description	Default (HEX)	Notes
High	Mid	Low						
0E	00	nn	1	-	Bulk Header	Normal Voice PRE1 (nn = 0 - 127)	-	
	01	nn	1	-		Normal Voice PRE2 (nn = 0 - 127)	-	
	02	nn	1	-		Normal Voice PRE3 (nn = 0 - 127)	-	
	03	nn	1	-		Normal Voice PRE4 (nn = 0 - 127)	-	
	04	nn	1	-		Normal Voice PRE5 (nn = 0 - 127)	-	
	05	nn	1	-		Normal Voice PRE6 (nn = 0 - 127)	-	
	06	nn	1	-		Normal Voice PRE7 (nn = 0 - 127)	-	
	07	nn	1	-		Normal Voice PRE8 (nn = 0 - 127)	-	
	08	nn	1	-		Normal Voice PRE9 (nn = 0 - 127)	-	
	09	nn	1	-		Normal Voice GM (nn = 0 - 127)	-	
	0A	nn	1	-		Normal Voice USER1 (nn = 0 - 127)	-	
	0B	nn	1	-		Normal Voice USER2 (nn = 0 - 127)	-	
	0C	nn	1	-		Normal Voice USER3 (nn = 0 - 127)	-	
	0F	nn	1	-		Normal Voice Edit Buffer (nn = 0)	-	
	20	nn	1	-		Drum Voice PRE (nn = 0 - 71)	-	
	21	nn	1	-		Drum Voice GM (nn = 0)	-	
	28	nn	1	-		Drum Voice USER (nn = 0 - 31)	-	
	29	nn	1	-		reserved	-	
	2F	nn	1	-		Drum Voice Edit Buffer (nn = 0)	-	
	30	nn	1	-		Mix Part Voice Edit Buffer (nn = 0 - 15) nn: part	-	
	31	nn	1	-		Mixing Voice (Current Song/Pattern) (nn = 0 - 15) nn: Voice Number	-	
	40	nn	1	-		Performance USER1 (nn = 0 - 127)	-	
	41	nn	1	-		Performance USER2 (nn = 0 - 127)	-	
	4F	nn	1	-		Performance Edit Buffer (nn = 0)	-	
	5F	nn	1	-		Multi Edit Buffer (nn = 0)	-	
	70	nn	1	-		Master USER (nn = 0 - 127)	-	
	7F	nn	1	-		Master Edit Buffer (nn = 0)	-	
0F	00	nn	1	-	Bulk Footer	Normal Voice PRE1 (nn = 0 - 127)	-	
	01	nn	1	-		Normal Voice PRE2 (nn = 0 - 127)	-	
	02	nn	1	-		Normal Voice PRE3 (nn = 0 - 127)	-	
	03	nn	1	-		Normal Voice PRE4 (nn = 0 - 127)	-	
	04	nn	1	-		Normal Voice PRE5 (nn = 0 - 127)	-	
	05	nn	1	-		Normal Voice PRE6 (nn = 0 - 127)	-	
	06	nn	1	-		Normal Voice PRE7 (nn = 0 - 127)	-	
	07	nn	1	-		Normal Voice PRE8 (nn = 0 - 127)	-	
	08	nn	1	-		Normal Voice PRE9 (nn = 0 - 127)	-	
	09	nn	1	-		Normal Voice GM (nn = 0 - 127)	-	
	0A	nn	1	-		Normal Voice USER1 (nn = 0 - 127)	-	
	0B	nn	1	-		Normal Voice USER2 (nn = 0 - 127)	-	
	0C	nn	1	-		Normal Voice USER3 (nn = 0 - 127)	-	
	0F	nn	1	-		Normal Voice Edit Buffer (nn = 0)	-	
	20	nn	1	-		Drum Voice PRE (nn = 0 - 71)	-	
	21	nn	1	-		Drum Voice GM (nn = 0)	-	
	28	nn	1	-		Drum Voice USER (nn = 0 - 31)	-	
	29	nn	1	-		reserved	-	
	2F	nn	1	-		Drum Voice Edit Buffer (nn = 0)	-	
	30	nn	1	-		Mix Part Voice Edit Buffer (nn = 0 - 15) nn: part	-	
	31	nn	1	-		Mixing Voice (Current Song/Pattern) (nn = 0 - 15) nn: Voice Number	-	
	40	nn	1	-		Performance USER1 (nn = 0 - 127)	-	
	41	nn	1	-		Performance USER2 (nn = 0 - 127)	-	
	4F	nn	1	-		Performance Edit Buffer (nn = 0)	-	
	5F	nn	1	-		Multi Edit Buffer (nn = 0)	-	
	70	nn	1	-		Master USER (nn = 0 - 127)	-	
	7F	nn	1	-		Master Edit Buffer (nn = 0)	-	

MIDI PARAMETER CHANGE TABLE (SYSTEM)

Address			Size	Data Range (HEX)	Parameter Name	Description	Default (HEX)	Notes
High	Mid	Low						
00	00	00	1	00 - 7F	Master Volume	0 - 127	7F	MIDI Master Volume
		01	1	28 - 58	Master Note Shift	-24 - +24 [semitones]	40	
		02	4	00 - 00 00 - 07 00 - 0F 00 - 0F	Master Tune	-102.4 - +102.3 [cent] 1st bit3-0 → bit15-12 2nd bit3-0 → bit11-8 3rd bit3-0 → bit7-4 4th bit3-0 → bit3-0	00 04 00 00 (0400)	MIDI Master Tuning
		06	1	00 - 01	Controller Reset	hold, reset	01	
		07	1	35 - 4B	Master Transpose	-11 - +11[semitones]	40	
		08	1	3D - 43	Master Octave Shift	-3 - +3	40	
		09	1	00 - 01	Local Switch	off, on	01	
		0A	1	00 - 10, 7F	Basic Receive Channel	1 - 16, omni, off	00	
		0B	1	00 - 0F, 7F	Keyboard Transmit Channel	1 - 16, off	00	
		0C	1	00 - 04	Knob Speed Table	Table1, 2, 3, 4, 5	02	
		0D	1	00 - 01	Stereo L&R Output Gain	00: 0dB, 01: +6dB	01	
		0E	1	00 - 02	Audio Connection Mode	VST Mode, 2 Stereo Rec Mode, 1 Stereo Rec Mode	01	
		0F	1	00 - 01	Direct Monitor Switch A/D In/Part	off, on	01	For the audio signal which is output via "USB 1/2."
		10	1	00 - 01	Direct Monitor Switch Part	off, on	01	For the audio signal which is output via "USB 3/4."
		11	1	00 - 04	Keyboard Velocity Curve	normal, soft, hard, wide, fixed	00	
		12	1	01 - 7F	Keyboard Fixed Velocity	1 - 127	40	
		13	1		reserved		01	
		14	1	00 - 01	Receive/Transmit Bank Select	off, on	01	
		15	1	00 - 01	Receive/Transmit Program Change	off, on	01	
		16	1		reserved		00	
		17	1		reserved		00	
		18	1	00 - 01	MIDI In/Out	MIDI, USB	01	
		19	1	00 - 03	System Effect On/Off Button	bit0: Reverb, bit1: Chorus	03	
		1A	1		reserved		00	
		1B	1	00 - 01	Knob Function Display Switch	off, on	01	
		1C	1	00 - 07	Knob Display Time	off, 1, 1.5, 2, 3, 4, 5, keep	02	
		1D	1	00 - 06	Auto Power Off Time	off, 5, 10, 15, 30, 60, 120	04	
		1E	1	00 - 05	Power on Mode	performance, voice (USR1), voice (PRE1), voice (GM), master, STORE+ENTER	04	
		1F	1	00 - 12	Bulk Dump Interval	0, 10, 20, 30, 40, 50, 60, 70, 80, 90, 100, 200, 300, 400, 500, 600, 700, 800, 900ms	00	
		20	1		reserved		00	
		21	1	00 - 01	LCD Mode	normal, reverse	00	
		22	1	00 - 0F	LCD Contrast	1 - 16	07	
		23	1	01 - 02	A/D Input Insertion Connect Type	ins A>B, ins B>A	01	For Voice Mode
		24	1	00 - 01	A/D Input Gain	mic, line	01	
		25	1	00 - 01	USB 1/2 Output Gain	00: 0dB, 01: +6dB	01	
		26	1	00 - 01	USB 3/4 Output Gain	00: 0dB, 01: +6dB	01	
		27	1		reserved		00	
		28	1	00 - 01	Voice ARP MIDI Out Switch	off, on	00	For Voice Mode
		29	1	00 - 0F	Voice ARP Transmit Channel	1 - 16	00	For Voice Mode
		2A	1	00 - 5F	Control Number Ribbon Controller	off, 1 - 95	16	
		2B	1	00 - 64	Control Number Foot Switch	off, 1 - 95, arp sw, play/stop, PC inc, PC dec, octave reset	60	
		2C	1	00 - 5F	Control Number Assign 1	off, 1 - 95	10	
		2D	1	00 - 5F	Control Number Assign 2	off, 1 - 95	11	
		2E	1	00 - 5F	Control Number Breath Controller	off, 1 - 95	02	
		2F	1	00 - 5F	Control Number Foot Controller 1	off, 1 - 95	0B	
		30	1	00 - 5F	Control Number Foot Controller 2	off, 1 - 95	04	
		31	1	00 - 5F	Control Number Assignable Function 1	off, 1 - 95	56	
		32	1	00 - 5F	Control Number Assignable Function 2	off, 1 - 95	57	

Address			Size	Data Range (HEX)	Parameter Name	Description	Default (HEX)	Notes
High	Mid	Low						
		33	1	00 - 02	Foot Switch Sustain Pedal Select	FC3 (Half On) FC3 (Half Off) FC4/5	00	
		34	1		reserved		00	
		35	1	00 - 0F	Performance Creator Layer Voice Bank	0 - 8: PRE1, PRE2, PRE3, PRE4, PRE5, PRE6, PRE7, PRE8, PRE9 9 - 11: USR1, USR2, USR3 12: PDR 13: UDR 14: GM 15: GMDR	03	PRE4 C05 PWM Simple
		36	1		reserved		00	
		37	1	00 - 7F	Performance Creator Layer Voice Program	1 - 128	24	
		38	1		reserved		00	
		39	1	00 - 0F	Performance Creator Split Voice Bank	0 - 8: PRE1, PRE2, PRE3, PRE4, PRE5, PRE6, PRE7, PRE8, PRE9 9 - 11: USR1, USR2, USR3 12: PDR 13: UDR 14: GM 15: GMDR	02	PRE3 D05 DarkBass
		3A	1		reserved		00	
		3B	1	00 - 7F	Performance Creator Split Voice Program	1 - 128	34	
		3C	1	00 - 02	Performance Creator Split Lower/Upper	both, lower, upper	01	
		3D	1		reserved		00	
		3E	1	00 - 0F	Performance Creator Drum Voice Bank	0 - 8: PRE1, PRE2, PRE3, PRE4, PRE5, PRE6, PRE7, PRE8, PRE9 9 - 11: USR1, USR2, USR3 12: PDR 13: UDR 14: GM 15: GMDR	0C	PDR A01 Power Standard Kit 1
		3F	1		reserved		00	
		40	1	00 - 7F	Performance Creator Drum Voice Program	1 - 128	00	
		41	1	00 - 01	Performance Creator Confirm Message	off, on	01	
		42	1		reserved		00	
		43	1		reserved		00	

TOTAL SIZE = 68 44 (HEX)

Address			Size	Data Range (HEX)	Parameter Name	Description	Default (HEX)	Notes
High	Mid	Low						
00	03	00	2	00 - 7F 00 - 7F	Insertion A Type	Refer to the "Effect Parameter List."	00 00	For A/D Part
		02	1	00 - 7F	Preset Number		00	
		03	1		reserved			
		04	2	00 - 7F 00 - 7F	Insertion A Parameter 1	Refer to the "Effect Parameter List."	00 00	
		06	2	00 - 7F 00 - 7F	Insertion A Parameter 2	:	00 00	
		08	2	00 - 7F 00 - 7F	Insertion A Parameter 3	:	00 00	
		0A	2	00 - 7F 00 - 7F	Insertion A Parameter 4	:	00 00	
		0C	2	00 - 7F 00 - 7F	Insertion A Parameter 5	:	00 00	
		0E	2	00 - 7F 00 - 7F	Insertion A Parameter 6	:	00 00	
		10	2	00 - 7F 00 - 7F	Insertion A Parameter 7	:	00 00	
		12	2	00 - 7F 00 - 7F	Insertion A Parameter 8	:	00 00	
		14	2	00 - 7F 00 - 7F	Insertion A Parameter 9	:	00 00	
		16	2	00 - 7F 00 - 7F	Insertion A Parameter 10	:	00 00	
		18	2	00 - 7F 00 - 7F	Insertion A Parameter 11	:	00 00	
		1A	2	00 - 7F 00 - 7F	Insertion A Parameter 12	:	00 00	
		1C	2	00 - 7F 00 - 7F	Insertion A Parameter 13	:	00 00	
		1E	2	00 - 7F 00 - 7F	Insertion A Parameter 14	:	00 00	
		20	2	00 - 7F 00 - 7F	Insertion A Parameter 15	:	00 00	
		22	2	00 - 7F 00 - 7F	Insertion A Parameter 16	:	00 00	

TOTAL SIZE = 36 24 (HEX)

Address			Size	Data Range (HEX)	Parameter Name	Description	Default (HEX)	Notes
High	Mid	Low						
00	04	00	2	00 - 7F 00 - 7F	Insertion B Type	Refer to the "Effect Parameter List."	00 00	For A/D Part
		02	1	00 - 7F	Preset Number		00	
		03	1		reserved			
		04	2	00 - 7F 00 - 7F	Insertion B Parameter 1	Refer to the "Effect Parameter List."	00 00	
		06	2	00 - 7F 00 - 7F	Insertion B Parameter 2	:	00 00	
		08	2	00 - 7F 00 - 7F	Insertion B Parameter 3	:	00 00	
		0A	2	00 - 7F 00 - 7F	Insertion B Parameter 4	:	00 00	
		0C	2	00 - 7F 00 - 7F	Insertion B Parameter 5	:	00 00	
		0E	2	00 - 7F 00 - 7F	Insertion B Parameter 6	:	00 00	
		10	2	00 - 7F 00 - 7F	Insertion B Parameter 7	:	00 00	
		12	2	00 - 7F 00 - 7F	Insertion B Parameter 8	:	00 00	
		14	2	00 - 7F 00 - 7F	Insertion B Parameter 9	:	00 00	
		16	2	00 - 7F 00 - 7F	Insertion B Parameter 10	:	00 00	
		18	2	00 - 7F 00 - 7F	Insertion B Parameter 11	:	00 00	
		1A	2	00 - 7F 00 - 7F	Insertion B Parameter 12	:	00 00	
		1C	2	00 - 7F 00 - 7F	Insertion B Parameter 13	:	00 00	
		1E	2	00 - 7F 00 - 7F	Insertion B Parameter 14	:	00 00	
		20	2	00 - 7F 00 - 7F	Insertion B Parameter 15	:	00 00	
		22	2	00 - 7F 00 - 7F	Insertion B Parameter 16	:	00 00	

TOTAL SIZE = 36 24 (HEX)

Address			Size	Data Range (HEX)	Parameter Name	Description	Default (HEX)	Notes
High	Mid	Low						
00	05	00	1	00 - 03	Click Mode	off, rec, rec/play, all	01	For SEQ
		01	1	00 - 04	Click Beat	16, 08, 04, 02, 01	02	For SEQ
		02	1	00 - 7F	Click Volume	0 - 127	64	For SEQ
		03	1	00 - 09	Click Type	1 - 10	00	For SEQ
		04	1	00 - 08	Recording Count	off, 1...8meas	01	For SEQ
		05	1		reserved			
		06	1	00 - 04	Pattern Quantize	1, 1/2, 1/4, 1/8, 1/16	00	For SEQ
		07	1	00 - 01	Pattern Tempo Hold Switch	off, on	00	For SEQ
		08	1	00 - 03	Song Event Chase	off, pc, pc+pb+ctrl, all	00	For SEQ
		09	1		reserved			
		0A	1	00 - 01	Load Mix Switch	off, on	01	For SEQ
		0B	1	00 - 03	Midi Sync	internal, external, auto, MTC	02	For SEQ
		0C	1	00 - 01	Midi Clock Out	off, on	01	For SEQ
		0D	1	00 - 03	Sequencer Control	off, in, out, in/out	03	For SEQ
		0E	1	00 - 17	MTC strat offset	0...23 (Hour)	00	For SEQ
		0F	1	00 - 3B		0...59 (Minute)	00	For SEQ
		10	1	00 - 3B		0...59 (Second)	00	For SEQ
		11	1	00 - 1D		0...29 (Frame)	00	For SEQ
		12	2	00 - 01 00 - 7F	MIDI In Filter	1st bit6:0: reserved 2nd bit6: off, on Exclusive 2nd bit5: off, on Channel After 2nd bit4: off, on Poly After 2nd bit3: off, on Program Change 2nd bit2: off, on Control Change 2nd bit1: off, on Pitch Bend 2nd bit0: off, on Note	01 7F	For SEQ
		14	2	00 - 01 00 - 7F	MIDI Out Filter	same as MIDI In Filter	01 7F	for SEQ

TOTAL SIZE = 22 16 (HEX)

Address			Size	Data Range (HEX)	Parameter Name	Description	Default (HEX)	Notes
High	Mid	Low						
00	06	00	1	00 - 03	DAW Select	Cubase, LogicPro, Digital Performer, SONAR	00	
		01	1	00 - 02	Program Change Mode	remote, PC, remote+PC	00	This is available only when "DAW Select" is set to "Cubase."
		02	1		reserved			
		03	1		reserved			
		04	1		reserved			
		05	1		reserved			

TOTAL SIZE = 6 06 (HEX)

Address			Size	Data Range (HEX)	Parameter Name	Description	Default (HEX)	Notes
High	Mid	Low						
00	20	00	1	34 - 4C	EQ Low Gain	-12 - +12 [dB]	40	For Voice Mode
		01	1	04 - 28	EQ Low Frequency	32 - 2000 [Hz]	0C	When setting the EQ shape peaking type, the range is 63Hz - 2.0kHz.
		02	1	01 - 78	EQ Low Q	0.1 - 12.0	07	When setting the EQ shape shelving type, this is not available.
		03	1	00 - 01	EQ Low Shape	shelv, peak	00	
		04	1	34 - 4C	EQ Low-Mid Gain	-12 - +12 [dB]	40	
		05	1	0E - 36	EQ Low-Mid Frequency	100 - 10.0 [kHz]	14	
		06	1	01 - 78	EQ Low-Mid Q	0.1 - 12.0	07	
		07	1		reserved		01	
		08	1	34 - 4C	EQ Mid Gain	-12 - +12 [dB]	40	
		09	1	0E - 36	EQ Mid Frequency	100 - 10.0 [kHz]	1C	
		0A	1	01 - 78	EQ Mid Q	0.1 - 12.0	07	
		0B	1		reserved		01	
		0C	1	34 - 4C	EQ High-Mid Gain	-12 - +12 [dB]	40	
		0D	1	0E - 36	EQ High-Mid Frequency	100 - 10.0 [kHz]	2C	
		0E	1	01 - 78	EQ High-Mid Q	0.1 - 12.0	07	
		0F	1		reserved		01	
		10	1	34 - 4C	EQ High Gain	-12 - +12 [dB]	40	
		11	1	1C - 3A	EQ High Frequency	0.5 - 16.0 [kHz]	34	
		12	1	01 - 78	EQ High Q	0.1 - 12.0	07	When setting the EQ shape shelving type, this is not available.
		13	1	00 - 01	EQ High Shape	shelv, peak	00	

TOTAL SIZE = 20 14 (HEX)

Address			Size	Data Range (HEX)	Parameter Name	Description	Default (HEX)	Notes
High	Mid	Low						
00	21	00	2	00 - 7F 00 - 7F	Master Effect Type	Refer to the "EffectParameter List."	08 20	For Voice Mode Multi Band Comp
		02	1	00 - 7F	Preset Number		00	Basic
		03	1		reserved			
		04	2	00 - 7F 00 - 7F	Master Effect Parameter 1	Refer to the "EffectParameter List."	:	Init value for Multi Band Comp / Basic
		06	2	00 - 7F 00 - 7F	Master Effect Parameter 2	:	:	Init value for Multi Band Comp / Basic
		08	2	00 - 7F 00 - 7F	Master Effect Parameter 3	:	:	Init value for Multi Band Comp / Basic
		0A	2	00 - 7F 00 - 7F	Master Effect Parameter 4	:	:	Init value for Multi Band Comp / Basic
		0C	2	00 - 7F 00 - 7F	Master Effect Parameter 5	:	:	Init value for Multi Band Comp / Basic
		0E	2	00 - 7F 00 - 7F	Master Effect Parameter 6	:	:	Init value for Multi Band Comp / Basic
		10	2	00 - 7F 00 - 7F	Master Effect Parameter 7	:	:	Init value for Multi Band Comp / Basic
		12	2	00 - 7F 00 - 7F	Master Effect Parameter 8	:	:	Init value for Multi Band Comp / Basic
		14	2	00 - 7F 00 - 7F	Master Effect Parameter 9	:	:	Init value for Multi Band Comp / Basic
		16	2	00 - 7F 00 - 7F	Master Effect Parameter 10	:	:	Init value for Multi Band Comp / Basic
		18	2	00 - 7F 00 - 7F	Master Effect Parameter 11	:	:	Init value for Multi Band Comp / Basic
		1A	2	00 - 7F 00 - 7F	Master Effect Parameter 12	:	:	Init value for Multi Band Comp / Basic
		1C	2	00 - 7F 00 - 7F	Master Effect Parameter 13	:	:	Init value for Multi Band Comp / Basic
		1E	2	00 - 7F 00 - 7F	Master Effect Parameter 14	:	:	Init value for Multi Band Comp / Basic
		20	2	00 - 7F 00 - 7F	Master Effect Parameter 15	:	:	Init value for Multi Band Comp / Basic
		22	2	00 - 7F 00 - 7F	Master Effect Parameter 16	:	:	Init value for Multi Band Comp / Basic
		24	1	00 - 01	Master Effect Switch	off, on	00	
		25	1		reserved			

TOTAL SIZE = 38 26 (HEX)

Address			Size	Data Range (HEX)	Parameter Name	Description	Default (HEX)	Notes
High	Mid	Low						
00	40	00	1	00 - 03	Audio Input Mode	L mono, R mono, L+R mono, stereo	03	Audio In Part (A/D)
		01	1	00 - 7F	Audio Input Part Volume	0 - 127	64	
		02	1	01 - 7F	Audio Input Part Pan	L63 - C - R63	40	
		03	1	00 - 7F	Audio Input Part Reverb Send	0 - 127	0C	
		04	1	00 - 7F	Audio Input Part Chorus Send	0 - 127	00	
		05	1		reserved		00	
		06	1	00 - 7F	Audio Input Part Dry Level	0 - 127	7F	
		07	1		reserved			

TOTAL SIZE = 8 08 (HEX)
n = part number 00 - 00

Address			Size	Data Range (HEX)	Parameter Name	Description	Default (HEX)	Notes
High	Mid	Low						
00	5n	00	1	20 - 7E	Quick Setup Name 1	32..126 (ASCII)	20	
		01	1	20 - 7E	Quick Setup Name 2	32..126 (ASCII)	20	
		02	1	20 - 7E	Quick Setup Name 3	32..126 (ASCII)	20	
		03	1	20 - 7E	Quick Setup Name 4	32..126 (ASCII)	20	
		04	1	20 - 7E	Quick Setup Name 5	32..126 (ASCII)	20	
		05	1	20 - 7E	Quick Setup Name 6	32..126 (ASCII)	20	
		06	1	20 - 7E	Quick Setup Name 7	32..126 (ASCII)	20	
		07	1	20 - 7E	Quick Setup Name 8	32..126 (ASCII)	20	
		08	1	00 - 06	Config Number Audio	---, config 1 - 6		
		09	1	00 - 06	Config Number MIDI	---, config 1 - 6		

TOTAL SIZE = 10 0A (HEX)
n = setup number 00 - 05

Address			Size	Data Range (HEX)	Parameter Name	Description	Default (HEX)	Notes
High	Mid	Low						
00	6n	00	1	00 - 02	Audio Connection Mode	VST Mode, 2 Stereo Rec Mode, 1 Stereo Rec Mode		
		01	1	00 - 01	Direct Monitor Switch A/D In/Part	off, on		For the audio signal which is output via "USB 1/2."
		02	1	00 - 01	Direct Monitor Switch Part	off, on		For the audio signal which is output via "USB 3/4."
		03	1		reserved			
		04	1		reserved			
		05	1		reserved			
		06	1		reserved			
		07	1		reserved			
		08	1		reserved			
		09	1		reserved			
		0A	1		reserved			
		0B	1		reserved			
		0C	1		reserved			
		0D	1		reserved			
		0E	1		reserved			
		0F	1		reserved			

TOTAL SIZE = 16 10 (HEX)
n = config number 00 - 05

Address			Size	Data Range (HEX)	Parameter Name	Description	Default (HEX)	Notes
High	Mid	Low						
00	7n	00	1	00 - 01	Local Switch	off, on		
		01	1	00 - 03	Midi Sync	internal, external, auto, MTC		
		02	1	00 - 01	Midi Clock Out	off, on		
		03	1	00 - 01	Track Internal Switch	all off, all on		For SEQ
		04	1	00 - 01	Track External Switch	all off, all on		For SEQ
		05	1	00 - 01	ARP MIDI Out Switch	all off, all on		
		06	1	00 - 0F, 7F	Keyboard Transmit Channel	1 - 16, off		
		07	1		reserved			
		08	1		reserved			
		09	1		reserved			
		0A	1		reserved			
		0B	1		reserved			
		0C	1		reserved			
		0D	1		reserved			
		0E	1		reserved			
		0F	1		reserved			

TOTAL SIZE = 16 10 (HEX)
n = config number 00 - 05

MIDI PARAMETER CHANGE TABLE (MASTER KEYBOARD)

Address			Size	Data Range (HEX)	Parameter Name	Description	Default (HEX)	Notes
High	Mid	Low						
33	00	00	1	20 - 7E	Master Name1	32..126 (ASCII)	l	
		01	1	20 - 7E	Master Name2	32..126 (ASCII)	n	
		02	1	20 - 7E	Master Name3	32..126 (ASCII)	i	
		03	1	20 - 7E	Master Name4	32..126 (ASCII)	t	
		04	1	20 - 7E	Master Name5	32..126 (ASCII)	i	
		05	1	20 - 7E	Master Name6	32..126 (ASCII)	a	
		06	1	20 - 7E	Master Name7	32..126 (ASCII)	l	
		07	1	20 - 7E	Master Name8	32..126 (ASCII)	i	
		08	1	20 - 7E	Master Name9	32..126 (ASCII)	z	
		09	1	20 - 7E	Master Name10	32..126 (ASCII)	e	
		0A	1	20 - 7E	Master Name11	32..126 (ASCII)	d	
		0B	1	20 - 7E	Master Name12	32..126 (ASCII)		
		0C	1	20 - 7E	Master Name13	32..126 (ASCII)	M	
		0D	1	20 - 7E	Master Name14	32..126 (ASCII)	a	
		0E	1	20 - 7E	Master Name15	32..126 (ASCII)	s	
		0F	1	20 - 7E	Master Name16	32..126 (ASCII)	t	
		10	1	20 - 7E	Master Name17	32..126 (ASCII)	e	
		11	1	20 - 7E	Master Name18	32..126 (ASCII)	r	
		12	1	20 - 7E	Master Name19	32..126 (ASCII)		
		13	1	20 - 7E	Master Name20	32..126 (ASCII)		
		14	1		reserved			
		15	1		reserved			
		16	1		reserved			
		17	1		reserved			
		18	1		reserved			
		19	1	00 - 03	Mode Change	0=Voice, 1=Performance, 2=Pattern, 3=Song	00	
		1A	1	00 - 7F	Bank Select MSB for Voice/Performance Mode	0..127	3F	
		1B	1	00 - 7F	Bank Select LSB for Voice/Performance Mode	0..127	00	
		1C	1	00 - 7F	Program Number	1..128	00	
		1D	1	00 - 01	Zone Switch	off, on	00	
		1E	1	00 - 33	Knob Function Select	bit0-3 KnobUp : 0=Tone1, 1=Tone2, 2=Tone3, 3=Volume/ Pan bit4-7 KnobLo : 0=EQ, 1=Fx, 2=Arp, 3=Volume/Pan	00	
		1F	1	00 - 01	Knob Zone Switch	off, on	01	This is available only when "Zone on/off" is set to on.

TOTAL SIZE = 32 20 (HEX)

Address			Size	Data Range (HEX)	Parameter Name	Description	Default (HEX)	Notes
High	Mid	Low						
		0E	1	00 - 5F	Control Upper Knob Control Number	off, 1 - 95	07	
		0F	1	00 - 5F	Control Lower Knob Control Number	off, 1 - 95	0A	

TOTAL SIZE = 16 10 (HEX)
nn = zone number 00 - 03

Address			Size	Data Range (HEX)	Parameter Name	Description	Default (HEX)	Notes
High	Mid	Low						
32	nn	00	1	00 - 3F	Transmit Channel, MIDI/TG Switch	bit6: reserved bit5: TG off, on bit4: MIDI off, on bit0-3: Ch1..16	Zone1: 30 Other: 00	
		01	1	3D - 43	Octave	-3..+3	40	
		02	1	35 - 4B	Transpose	-11..+11 (semitones)	40	
		03	1	00 - 7F	Note Limit Low	C-2..G8	00	
		04	1	00 - 7F	Note Limit High	C-2..G8	7F	
		05	1		reserved		7F	
		06	1	00 - 7F	MIDI Volume	0..127	64	
		07	1	00 - 7F	MIDI Pan	0..127	40	
		08	1	00 - 7F	MIDI Bank MSB	0..127	00	
		09	1	00 - 7F	MIDI Bank LSB	0..127	00	
		0A	1	00 - 7F	MIDI Program Number	1..128	00	
		0B	1	00 - 1F	reserved Transmit Program Change for MIDI Transmit Bank Select for MIDI reserved Transmit Program Change for TG Transmit Bank Select for TG	bit6-5: reserved bit4: off, on Program Change bit3: off, on Bank Select bit2: reserved bit1: off, on Program Change bit0: off, on Bank Select	00	
		0C	1	00 - 7F	Transmit PB reserved Transmit Assignable Function 2 Transmit Assignable Function 1 Transmit Sustain Transmit Pan Transmit Volume/Expression	bit6: off, on PB bit5: reserved bit4: off, on Assignable Function 2 bit3: off, on Assignable Function 1 bit2: off, on Sustain bit1: off, on Pan bit0: off, on Volume/Expression	67	Ctrl#7, 11
		0D	1	00 - 7F	Transmit Assignable Knob reserved Transmit MW Transmit BC Transmit FC1 Transmit FS reserved	bit6: off, on Assignable Knob bit5: reserved bit4: off, on MW bit3: off, on BC bit2: off, on FC1 bit1: off, on FS bit0: reserved	7F	

MIDI PARAMETER CHANGE TABLE (PERFORMANCE COMMON)

Address			Size	Data Range (HEX)	Parameter Name	Description	Default (HEX)	Notes
High	Mid	Low						
30	00	00	1	20-7E	Performance Name1	32..126 (ASCII)	l	
		01	1	20-7E	Performance Name2	32..126 (ASCII)	n	
		02	1	20-7E	Performance Name3	32..126 (ASCII)	i	
		03	1	20-7E	Performance Name4	32..126 (ASCII)	t	
		04	1	20-7E	Performance Name5	32..126 (ASCII)	i	
		05	1	20-7E	Performance Name6	32..126 (ASCII)	a	
		06	1	20-7E	Performance Name7	32..126 (ASCII)	l	
		07	1	20-7E	Performance Name8	32..126 (ASCII)	i	
		08	1	20-7E	Performance Name9	32..126 (ASCII)	z	
		09	1	20-7E	Performance Name10	32..126 (ASCII)	e	
		0A	1	20-7E	Performance Name11	32..126 (ASCII)	d	
		0B	1	20-7E	Performance Name12	32..126 (ASCII)	P	
		0C	1	20-7E	Performance Name13	32..126 (ASCII)	e	
		0D	1	20-7E	Performance Name14	32..126 (ASCII)	r	
		0E	1	20-7E	Performance Name15	32..126 (ASCII)	f	
		0F	1	20-7E	Performance Name16	32..126 (ASCII)	o	
		10	1	20-7E	Performance Name17	32..126 (ASCII)	r	
		11	1	20-7E	Performance Name18	32..126 (ASCII)	m	
		12	1	20-7E	Performance Name19	32..126 (ASCII)		
		13	1	20-7E	Performance Name20	32..126 (ASCII)		
		14	1		reserved			
		15	1		reserved			
		16	1		reserved			
		17	1		reserved			
		18	1	00-07	Performance Category (Main)	0..7	07 (NoAsg)	
		19	1	00-0B	Performance Category (Sub)	0..11	00 (-)	
		1A	1		reserved			
		1B	1		reserved			
		1C	1		reserved			
		1D	1		reserved			
30	00	1E	1	00-33	Knob Function Select	bit0-3 KnobUp : 0=Tone1, 1=Tone2, 2=Tone3, 3=Volume/ Pan bit4-7 KnobLo : 0=EQ, 1=Fx, 2=Arp, 3=Volume/Pan	00	
		1F	1	01-7F	Pan	L63..C..R63	40	
		20	1		reserved			
		21	1	00-7F	AEG Attack Time	-64..+63	40	
		22	1	00-7F	AEG Decay Time	-64..+63	40	
		23	1	00-7F	AEG Sustain Level	-64..+63	40	
		24	1	00-7F	AEG Release Time	-64..+63	40	
		25	1	00-7F	FEG Attack Time	-64..+63	40	
		26	1	00-7F	FEG Decay Time	-64..+63	40	
		27	1		reserved			
		28	1	00-7F	FEG Release Time	-64..+63	40	
		29	1	00-7F	FEG Depth	-64..+63	40	
		2A	1	00-7F	Cutoff Frequency	-64..+63	40	
		2B	1	00-7F	Resonance	-64..+63	40	
		2C	1		reserved			
		2D	1		reserved			
		2E	1	00-7F	EQ Low Frequency	-64..+63	40	
		2F	1	00-7F	EQ Low Gain	-64..+63	40	
		30	1		reserved			
		31	1	00-7F	EQ Mid Frequency	-64..+63	40	
		32	1	00-7F	EQ Mid Gain	-64..+63	40	
		33	1	00-7F	EQ Mid Q	-64..+63	40	
		34	1		reserved			
		35	1	00-7F	EQ High Frequency	-64..+63	40	
		36	1	00-7F	EQ High Gain	-64..+63	40	
		37	1		reserved			
		38	1	00-7F	Volume	0..127	7F	
		39	1	00-7F	Portamento Time	-64..+63	40	
		3A	1	00-01	Portamento Switch	off, on	01	
		3B	1	00-7F	Reverb Send	0..127	7F	
		3C	1	00-7F	Chorus Send	0..127	7F	
30	00	3D	1		reserved			
		3E	1		reserved			
		3F	1	00-01	Assignable Function 1 Mode	momentary, latch	01	
		40	1	00-01	Assignable Function 2 Mode	momentary, latch	01	
		41	1		reserved			
		42	1	01-7F	Split Point	C#-2..G8	3C	
		43	1	00-01	Split Switch	off, on	00	
		44	1		reserved			
		45	1		reserved			
		46	1		reserved			
		47	1		reserved			
		48	1		reserved			
		49	1		reserved			

Address			Size	Data Range (HEX)	Parameter Name	Description	Default (HEX)	Notes
High	Mid	Low						
		4A	1		reserved			
		4B	1	01-02	A/D Input Insertion Connect Type	ins A>B, ins B>A	01	
		4C	4	00-00 00-20 00-00 00-0F	Insertion Part Sw	1st bit4-0: reserved 2nd bit6: reserved 2nd bit5: off, on A/D Part 2nd bit4-0: reserved 3rd bit6-0: reserved 4th bit6-4: reserved 4th bit3: off, on Part4 4th bit2: off, on Part3 4th bit1: off, on Part2 4th bit0: off, on Part1	00 20 00 0F	

TOTAL SIZE = 80 50 (HEX)

Address			Size	Data Range (HEX)	Parameter Name	Description	Default (HEX)	Notes
High	Mid	Low						
30	30	00	1	00-05	ARP SF Select	SF1 - SF6	00	
		01	1		reserved			
		02	2	00-02 05-2C	ARP Tempo	5..300	00 5A	
		04	1	00-01	ARP Common Switch	off, on	00	
		05	1	00-07	ARP Synchro Quantize Value	off, 32th, 16th_Triplet, 16th, 8th_Triplet, 8th, 4th_Triplet, 4th	00	
		06	2	00-01 1C-64	ARP Quantize Strength Offset	-100 ... +100	01 00	
		08	2	00-01 1C-64	ARP Gate Time Rate Offset	-100 ... +100	01 00	
		0A	2	00-01 1C-64	ARP Velocity Rate Offset	-100 ... +100	01 00	
		0C	2	00-01 08-78	ARP Swing Offset	-120 ... +120	01 00	

TOTAL SIZE = 14 0E (HEX)

Address			Size	Data Range (HEX)	Parameter Name	Description	Default (HEX)	Notes
High	Mid	Low						
30	01	00	2	00-7F 00-7F	Reverb Type	Refer to the "Effect Parameter List."	01 00	Rev-X Hall
		02	1	00-7F	Preset Number		00	Basic
		03	1		reserved			
		04	2	00-7F 00-7F	Reverb Parameter 1	Refer to the "Effect Parameter List."		Init value for Rev-X Hall / Basic
		06	2	00-7F 00-7F	Reverb Parameter 2	:		Init value for Rev-X Hall / Basic
		08	2	00-7F 00-7F	Reverb Parameter 3	:		Init value for Rev-X Hall / Basic
		0A	2	00-7F 00-7F	Reverb Parameter 4	:		Init value for Rev-X Hall / Basic
		0C	2	00-7F 00-7F	Reverb Parameter 5	:		Init value for Rev-X Hall / Basic
		0E	2	00-7F 00-7F	Reverb Parameter 6	:		Init value for Rev-X Hall / Basic
		10	2	00-7F 00-7F	Reverb Parameter 7	:		Init value for Rev-X Hall / Basic
		12	2	00-7F 00-7F	Reverb Parameter 8	:		Init value for Rev-X Hall / Basic
		14	2	00-7F 00-7F	Reverb Parameter 9	:		Init value for Rev-X Hall / Basic
		16	2	00-7F 00-7F	Reverb Parameter 10	:		Init value for Rev-X Hall / Basic
		18	2	00-7F 00-7F	Reverb Parameter 11	:		Init value for Rev-X Hall / Basic
		1A	2	00-7F 00-7F	Reverb Parameter 12	:		Init value for Rev-X Hall / Basic
		1C	2	00-7F 00-7F	Reverb Parameter 13	:		Init value for Rev-X Hall / Basic
		1E	2	00-7F 00-7F	Reverb Parameter 14	:		Init value for Rev-X Hall / Basic
		20	2	00-7F 00-7F	Reverb Parameter 15	:		Init value for Rev-X Hall / Basic
		22	2	00-7F 00-7F	Reverb Parameter 16	:		Init value for Rev-X Hall / Basic
		24	1	00-7F	Reverb Return	-∞dB...0dB...+6dB (0...96...127)	40	
		25	1	01-7F	Reverb Pan	L63...C...R63	40	

TOTAL SIZE = 38 26 (HEX)

Address			Size	Data Range (HEX)	Parameter Name	Description	Default (HEX)	Notes
High	Mid	Low						
30	02	00	2	00 - 7F 00 - 7F	Chorus Type	Refer to the "Effect Parameter List."	03 00	G Chorus
	02	01	1	00 - 7F	Preset Number		00	Basic
	03	01	1		reserved			
	04	2	2	00 - 7F 00 - 7F	Chorus Parameter 1	Refer to the "Effect Parameter List."		Init value for G Chorus / Basic
	06	2	2	00 - 7F 00 - 7F	Chorus Parameter 2	:		Init value for G Chorus / Basic
	08	2	2	00 - 7F 00 - 7F	Chorus Parameter 3	:		Init value for G Chorus / Basic
	0A	2	2	00 - 7F 00 - 7F	Chorus Parameter 4	:		Init value for G Chorus / Basic
	0C	2	2	00 - 7F 00 - 7F	Chorus Parameter 5	:		Init value for G Chorus / Basic
	0E	2	2	00 - 7F 00 - 7F	Chorus Parameter 6	:		Init value for G Chorus / Basic
	10	2	2	00 - 7F 00 - 7F	Chorus Parameter 7	:		Init value for G Chorus / Basic
	12	2	2	00 - 7F 00 - 7F	Chorus Parameter 8	:		Init value for G Chorus / Basic
	14	2	2	00 - 7F 00 - 7F	Chorus Parameter 9	:		Init value for G Chorus / Basic
	16	2	2	00 - 7F 00 - 7F	Chorus Parameter 10	:		Init value for G Chorus / Basic
	18	2	2	00 - 7F 00 - 7F	Chorus Parameter 11	:		Init value for G Chorus / Basic
	1A	2	2	00 - 7F 00 - 7F	Chorus Parameter 12	:		Init value for G Chorus / Basic
	1C	2	2	00 - 7F 00 - 7F	Chorus Parameter 13	:		Init value for G Chorus / Basic
	1E	2	2	00 - 7F 00 - 7F	Chorus Parameter 14	:		Init value for G Chorus / Basic
	20	2	2	00 - 7F 00 - 7F	Chorus Parameter 15	:		Init value for G Chorus / Basic
	22	2	2	00 - 7F 00 - 7F	Chorus Parameter 16	:		Init value for G Chorus / Basic
	24	1	1	00 - 7F	Chorus Return	--dB...0dB...+6dB (0...96...127)	60	
	25	1	1	01 - 7F	Chorus Pan	L63...C...R63	40	
	26	1	1	00 - 7F	Send Chorus To Reverb	--dB...0dB (0...127)	00	
	27	1	1		reserved			

TOTAL SIZE = 40 28 (HEX)

Address			Size	Data Range (HEX)	Parameter Name	Description	Default (HEX)	Notes
High	Mid	Low						
30	03	00	2	00 - 7F 00 - 7F	Insertion A Type	Refer to the "Effect Parameter List."	00 00	For A/D Part
	02	01	1	00 - 7F	Preset Number		00	
	03	01	1		reserved			
	04	2	2	00 - 7F 00 - 7F	Insertion A Parameter 1	Refer to the "Effect Parameter List."	00 00	
	06	2	2	00 - 7F 00 - 7F	Insertion A Parameter 2	:	00 00	
	08	2	2	00 - 7F 00 - 7F	Insertion A Parameter 3	:	00 00	
	0A	2	2	00 - 7F 00 - 7F	Insertion A Parameter 4	:	00 00	
	0C	2	2	00 - 7F 00 - 7F	Insertion A Parameter 5	:	00 00	
	0E	2	2	00 - 7F 00 - 7F	Insertion A Parameter 6	:	00 00	
	10	2	2	00 - 7F 00 - 7F	Insertion A Parameter 7	:	00 00	
	12	2	2	00 - 7F 00 - 7F	Insertion A Parameter 8	:	00 00	
	14	2	2	00 - 7F 00 - 7F	Insertion A Parameter 9	:	00 00	
	16	2	2	00 - 7F 00 - 7F	Insertion A Parameter 10	:	00 00	
	18	2	2	00 - 7F 00 - 7F	Insertion A Parameter 11	:	00 00	
	1A	2	2	00 - 7F 00 - 7F	Insertion A Parameter 12	:	00 00	
	1C	2	2	00 - 7F 00 - 7F	Insertion A Parameter 13	:	00 00	
	1E	2	2	00 - 7F 00 - 7F	Insertion A Parameter 14	:	00 00	
	20	2	2	00 - 7F 00 - 7F	Insertion A Parameter 15	:	00 00	
	22	2	2	00 - 7F 00 - 7F	Insertion A Parameter 16	:	00 00	

TOTAL SIZE = 36 24 (HEX)

Address			Size	Data Range (HEX)	Parameter Name	Description	Default (HEX)	Notes
High	Mid	Low						
30	04	00	2	00 - 7F 00 - 7F	Insertion B Type	Refer to the "Effect Parameter List."	00 00	For A/D Part
	02	01	1	00 - 7F	Preset Number		00	
	03	01	1		reserved			
	04	2	2	00 - 7F 00 - 7F	Insertion B Parameter 1	Refer to the "Effect Parameter List."	00 00	
	06	2	2	00 - 7F 00 - 7F	Insertion B Parameter 2	:	00 00	
	08	2	2	00 - 7F 00 - 7F	Insertion B Parameter 3	:	00 00	
	0A	2	2	00 - 7F 00 - 7F	Insertion B Parameter 4	:	00 00	
	0C	2	2	00 - 7F 00 - 7F	Insertion B Parameter 5	:	00 00	
	0E	2	2	00 - 7F 00 - 7F	Insertion B Parameter 6	:	00 00	
	10	2	2	00 - 7F 00 - 7F	Insertion B Parameter 7	:	00 00	
	12	2	2	00 - 7F 00 - 7F	Insertion B Parameter 8	:	00 00	
	14	2	2	00 - 7F 00 - 7F	Insertion B Parameter 9	:	00 00	
	16	2	2	00 - 7F 00 - 7F	Insertion B Parameter 10	:	00 00	
	18	2	2	00 - 7F 00 - 7F	Insertion B Parameter 11	:	00 00	
	1A	2	2	00 - 7F 00 - 7F	Insertion B Parameter 12	:	00 00	
	1C	2	2	00 - 7F 00 - 7F	Insertion B Parameter 13	:	00 00	
	1E	2	2	00 - 7F 00 - 7F	Insertion B Parameter 14	:	00 00	
	20	2	2	00 - 7F 00 - 7F	Insertion B Parameter 15	:	00 00	
	22	2	2	00 - 7F 00 - 7F	Insertion B Parameter 16	:	00 00	

TOTAL SIZE = 36 24 (HEX)

Address			Size	Data Range (HEX)	Parameter Name	Description	Default (HEX)	Notes
High	Mid	Low						
30	10	00	1	34 - 4C	EQ Low Gain	-12 - +12 [dB]	40	
	01	1	1	04 - 28	EQ Low Frequency	32 - 2000 [Hz]	0C	When setting the EQ shape peaking type, the range is 63Hz - 2.0kHz.
	02	1	1	01 - 78	EQ Low Q	0.1 - 12.0	07	When setting the EQ shape shelving type, this is not available.
	03	1	1	00 - 01	EQ Low Shape	shelv, peak	00	
	04	1	1	34 - 4C	EQ Low-Mid Gain	-12 - +12 [dB]	40	
	05	1	1	0E - 36	EQ Low-Mid Frequency	100 - 10.0 [kHz]	14	
	06	1	1	01 - 78	EQ Low-Mid Q	0.1 - 12.0	07	
	07	1	1		reserved		01	
	08	1	1	34 - 4C	EQ Mid Gain	-12 - +12 [dB]	40	
	09	1	1	0E - 36	EQ Mid Frequency	100 - 10.0 [kHz]	1C	
	0A	1	1	01 - 78	EQ Mid Q	0.1 - 12.0	07	
	0B	1	1		reserved		01	
	0C	1	1	34 - 4C	EQ High-Mid Gain	-12 - +12 [dB]	40	
	0D	1	1	0E - 36	EQ High-Mid Frequency	100 - 10.0 [kHz]	2C	
	0E	1	1	01 - 78	EQ High-Mid Q	0.1 - 12.0	07	
	0F	1	1		reserved		01	
	10	1	1	34 - 4C	EQ High Gain	-12 - +12 [dB]	40	
	11	1	1	1C - 3A	EQ High Frequency	0.5 - 16.0 [kHz]	34	
	12	1	1	01 - 78	EQ High Q	0.1 - 12.0	07	
	13	1	1	00 - 01	EQ High Shape	shelv, peak	00	

TOTAL SIZE = 20 14 (HEX)

MIDI PARAMETER CHANGE TABLE (PERFORMANCE PART)

Address			Size	Data Range (HEX)	Parameter Name	Description	Default (HEX)	Notes
High	Mid	Low						
30	11	00	2	00 – 7F 00 – 7F	Master Effect Type	Refer to the "Effect Parameter List."	08 20	Multi Band Comp
		02	1	00 – 7F	Preset Number		00	Basic
		03	1		reserved			
		04	2	00 – 7F 00 – 7F	Master Effect Parameter 1	Refer to the "Effect Parameter List."		Init value for Multi Band Comp / Basic
		06	2	00 – 7F 00 – 7F	Master Effect Parameter 2	:		Init value for Multi Band Comp / Basic
		08	2	00 – 7F 00 – 7F	Master Effect Parameter 3	:		Init value for Multi Band Comp / Basic
		0A	2	00 – 7F 00 – 7F	Master Effect Parameter 4	:		Init value for Multi Band Comp / Basic
		0C	2	00 – 7F 00 – 7F	Master Effect Parameter 5	:		Init value for Multi Band Comp / Basic
		0E	2	00 – 7F 00 – 7F	Master Effect Parameter 6	:		Init value for Multi Band Comp / Basic
		10	2	00 – 7F 00 – 7F	Master Effect Parameter 7	:		Init value for Multi Band Comp / Basic
		12	2	00 – 7F 00 – 7F	Master Effect Parameter 8	:		Init value for Multi Band Comp / Basic
		14	2	00 – 7F 00 – 7F	Master Effect Parameter 9	:		Init value for Multi Band Comp / Basic
		16	2	00 – 7F 00 – 7F	Master Effect Parameter 10	:		Init value for Multi Band Comp / Basic
		18	2	00 – 7F 00 – 7F	Master Effect Parameter 11	:		Init value for Multi Band Comp / Basic
		1A	2	00 – 7F 00 – 7F	Master Effect Parameter 12	:		Init value for Multi Band Comp / Basic
		1C	2	00 – 7F 00 – 7F	Master Effect Parameter 13	:		Init value for Multi Band Comp / Basic
		1E	2	00 – 7F 00 – 7F	Master Effect Parameter 14	:		Init value for Multi Band Comp / Basic
		20	2	00 – 7F 00 – 7F	Master Effect Parameter 15	:		Init value for Multi Band Comp / Basic
		22	2	00 – 7F 00 – 7F	Master Effect Parameter 16	:		Init value for Multi Band Comp / Basic
		24	1	00 – 01	Master Effect Switch	off, on	00	
		25	1		reserved			

TOTAL SIZE = 38 26 (HEX)

Address			Size	Data Range (HEX)	Parameter Name	Description	Default (HEX)	Notes
High	Mid	Low						
31	pp	00	1	00 – 01	Part Switch	off, on	01	
		01	1	00 – 7F	Bank Select MSB	0 – 127	3F	
		02	1	00 – 7F	Bank Select LSB	0 – 127	00	
		03	1	00 – 7F	Program Number	1 – 128	00	
		04	1	7F	reserved	off		
		05	1	00 – 01	Mono/Poly	mono, poly	01	
		06	1	01 – 7F	Velocity Limit Low	1 – 127	01	
		07	1	01 – 7F	Velocity Limit High	1 – 127	7F	
		08	1	00 – 7F	Note Limit Low	C-2 – G8	00	
		09	1	00 – 7F	Note Limit High	C-2 – G8	7F	
		0A	1	10 – 58	Pitch Bend Range Upper	-48 – +24	42	
		0B	1	10 – 58	Pitch Bend Range Lower	-48 – +24	3E	
		0C	1	00 – 7F	Velocity Sensitivity Depth	0 – 127	40	
		0D	1	00 – 7F	Velocity Sensitivity Offset	0 – 127	40	
		0E	1	00 – 7F	Volume	0 – 127	64	
		0F	1	01 – 7F	Pan	L63 – C – R63	40	
		10	2	00 – 0F 00 – 0F	Detune	-12.8 – +12.7 [Hz] 1st bit3-0 → bit7-4, 2nd bit3-0 → bit3-0	08 00 (80)	
		12	1	00 – 7F	Reverb Send	0 – 127	0C	
		13	1	00 – 7F	Chorus Send	0 – 127	00	
		14	1		reserved			
		15	1	00 – 7F	Dry Level	0 – 127	7F	
		16	1	28 – 58	Note Shift	-24 – +24 [semitones]	40	
		17	1		reserved			
		18	1	00 – 01	Param. with Voice	off, on	00	
		19	1	00 – 01	Voice with Arp	off, on	00	
		1A	1	00 – 01	Portamento Switch	off, on	00	
		1B	1	00 – 7F	Portamento Time	0 – 127	40	
		1C	1	00 – 01	Portamento Mode	fingered, fulltime	01	
		1D	1	00 – 02	Split Lower/Upper	both, lower, upper	00	
		1E	1	00 – 01	USB Audio Output Select	USB 1/2, USB 3/4	01	This is available only when the audio connect mode is set to 2 Stereo Rec mode.
31	pp	1F	1	18 – 7C	Receive PB Receive AT Receive Control Change reserved	bit6: off, on PB bit5: off, on AT bit2: off, on Control Change bit1-0: reserved	7C	
		20	1	02 – 6F	Receive FC2 Receive FC1 reserved Receive MW Receive Sustain/Sostenute Receive Expression	bit6: off, on FC2 bit5: off, on FC1 bit4: reserved bit3: off, on MW bit2: off, on Sustain/Sostenute bit0: off, on Expression	6F	Only for Normal Voices
		21	1	00 – 7F	Receive Assignable Function 2 Receive Assignable Function 1 Receive Assignable Knob 2 Receive Assignable Knob 1 Receive RB Receive BC Receive FS	bit6: off, on AF2 bit5: off, on AF1 bit4: off, on AKN2 bit3: off, on AKN1 bit2: off, on RB bit1: off, on BC bit0: off, on FS	7F	
31	pp	22	1	00 – 01	Voice Element Pan	off, on	01	
		23	1	00 – 7F	AEG Attack Time	-64 – +63	40	
		24	1	00 – 7F	AEG Decay Time	-64 – +63	40	
		25	1	00 – 7F	AEG Sustain Level	-64 – +63	40	Only for Normal Voice
		26	1	00 – 7F	AEG Release Time	-64 – +63	40	Only for Normal Voice
		27	1	00 – 7F	FEG Attack Time	-64 – +63	40	Only for Normal Voice
		28	1	00 – 7F	FEG Decay Time	-64 – +63	40	Only for Normal Voice
		29	1	00 – 7F	FEG Sustain Level	-64 – +63	40	Only for Normal Voice
		2A	1	00 – 7F	FEG Release Time	-64 – +63	40	Only for Normal Voice
		2B	1	00 – 7F	FEG Depth	-64 – +63	40	Only for Normal Voice
		2C	1		reserved			
		2D	1	00 – 7F	Filter Cutoff Frequency	-64 – +63	40	
		2E	1	00 – 7F	Filter Resonance/Width	-64 – +63	40	
31	pp	2F	1		reserved			
		30	2	00 – 01 2E – 36	EQ Low Frequency	50.1 – 2.00k	00 36	
		32	1	20 – 60	EQ Low Gain	-32 – +32 (-12.00db – +12.00db)	40	

Address			Size	Data Range (HEX)	Parameter Name	Description	Default (HEX)	Notes
High	Mid	Low						
		33	1		reserved			
		34	2	00 – 01 53 – 71	EQ Mid Frequency	139.7 – 10.1k	01 0D	
		36	1	20 – 60	EQ Mid Gain	-32 – +32 (-12.00db – +12.00db)	40	
		37	1	00 – 1F	EQ Mid Q	0 – 31 (0.7 – 10.3)	00	
		38	2	01 – 01 03 – 7F	EQ High Frequency	503.8 – 14k	01 67	
		3A	1	20 – 60	EQ High Gain	-32 – +32 (-12.00db – +12.00db)	40	
		3B	1		reserved			
31	pp	3C	1	00 – 7F	Assignable Knob 1 Value	-64 – +63	40	
		3D	1	00 – 7F	Assignable Knob 2 Value	-64 – +63	40	

TOTAL SIZE = 62 3E (HEX)
pp = part number 00 – 03

Address			Size	Data Range (HEX)	Parameter Name	Description	Default (HEX)	Notes
High	Mid	Low						
34	pp	00	1	00 – 01	ARP Switch	off, on	00	
		01	1	00 – 01	ARP MIDI Out Switch	off, on	00	
		02	1	00 – 10	ARP Transmit Channel	1..16, kbd-ch	Part No.	
		03	1	00 – 01	ARP Play Only	off, on	00	
		04	1	00 – 01	ARP Fixed SD/BD	off, on	00	
		05	1		reserved			
		06	1	00 – 01	ARP Loop	off, on	01	
		07	1	00 – 02	ARP Hold	sync-off, off, on	01	
		08	1	00 – 06	ARP Unit Multiply	50%, 66%, 75%, 100%, 133%, 150%, 200%	03	
		09	1	00 – 7F	ARP Note Limit Low	C-2..G8	00	
		0A	1	00 – 7F	ARP Note Limit High	C-2..G8	7F	
		0B	1	01 – 7F	ARP Velocity Limit Low	1 – 127	01	
		0C	1	01 – 7F	ARP Velocity Limit High	1 – 127	7F	
		0D	1	00 – 04	ARP Key Mode	sort, thru, direct, sort+direct, thru+direct	00	
		0E	1	00 – 01	ARP Velocity Mode	original, thru	00	
		0F	1	00 – 01	ARP Change Timing	realtime, measure	01	
		10	1	01 – 07	ARP Quantize Value	32th, 16th_Triplet, 16th, 8th_Triplet, 8th, 4th_Triplet, 4th	03	
		11	1	00 – 64	ARP Quantize Strength	0...100%	00	
		12	2	00 – 01 00 – 48	ARP Velocity Rate	0...200%	00 64	
		14	2	00 – 01 00 – 48	ARP Gate Time Rate	0...200%	00 64	
		16	1		reserved			
		17	1		reserved			
		18	1		reserved			
		19	1		reserved			
		1A	2	00 – 01 08 – 78	ARP Swing	-120 ... 0 ... +120	01 00	
		1C	1	00 – 7F	ARP Accent Velocity Threshold	off, 1 ... 127	40	
		1D	1	00 – 01	ARP Accent Start Quantize	off, on	01	
		1E	1	3D – 43	ARP Octave Range	-3 ... 0 ... +3	40	
		1F	1	36 – 4A	ARP Output Octave Shift	-10 ... 0 ... +10	40	
		20	1	00 – 01	ARP Trigger Mode	gate, toggle	00	
		21	1	00 – 01	ARP Random SFX	off, on	01	
		22	1	00 – 01	ARP Random SFX Keyon Control	off, on	01	
		23	1	00 – 7F	ARP Random SFX Velocity Offset	-64 ... 0 ... +63	40	
		24	2	00 – 01 1C – 64	ARP Assign Velocity Rate Offset SF1	-100 ... 0 ... +100	01 00	
		26	2	00 – 01 1C – 64	ARP Assign Gate Time Rate Offset SF1	-100 ... 0 ... +100	01 00	
		28	2	00 – 01 1C – 64	ARP Assign Velocity Rate Offset SF2	-100 ... 0 ... +100	01 00	
		2A	2	00 – 01 1C – 64	ARP Assign Gate Time Rate Offset SF2	-100 ... 0 ... +100	01 00	
		2C	2	00 – 01 1C – 64	ARP Assign Velocity Rate Offset SF3	-100 ... 0 ... +100	01 00	
		2E	2	00 – 01 1C – 64	ARP Assign Gate Time Rate Offset SF3	-100 ... 0 ... +100	01 00	
		30	2	00 – 01 1C – 64	ARP Assign Velocity Rate Offset SF4	-100 ... 0 ... +100	01 00	
		32	2	00 – 01 1C – 64	ARP Assign Gate Time Rate Offset SF4	-100 ... 0 ... +100	01 00	
		34	2	00 – 01 1C – 64	ARP Assign Velocity Rate Offset SF5	-100 ... 0 ... +100	01 00	
		36	2	00 – 01 1C – 64	ARP Assign Gate Time Rate Offset SF5	-100 ... 0 ... +100	01 00	
		38	2	00 – 01 1C – 64	ARP Assign Velocity Rate Offset SF6	-100 ... 0 ... +100	01 00	
		3A	2	00 – 01 1C – 64	ARP Assign Gate Time Rate Offset SF6	-100 ... 0 ... +100	01 00	

Address			Size	Data Range (HEX)	Parameter Name	Description	Default (HEX)	Notes
High	Mid	Low						
		3C	2	00 – 3E 00 – 2D, 40 – 41 00 – 7F	ARP SF1 Assign Type	off, Preset 0001 ... 7981, User 001 ... 256	05 4A	MA_Pf Arp1
		3E	2	00 – 3E 00 – 2D, 40 – 41 00 – 7F	ARP SF2 Assign Type	off, Preset 0001 ... 7981, User 001 ... 256	00 00	off
		40	2	00 – 3E 00 – 2D, 40 – 41 00 – 7F	ARP SF3 Assign Type	off, Preset 0001 ... 7981, User 001 ... 256	00 00	off
		42	2	00 – 3E 00 – 2D, 40 – 41 00 – 7F	ARP SF4 Assign Type	off, Preset 0001 ... 7981, User 001 ... 256	00 00	off
		44	2	00 – 3E 00 – 2D, 40 – 41 00 – 7F	ARP SF5 Assign Type	off, Preset 0001 ... 7981, User 001 ... 256	00 00	off
		46	2	00 – 3E 00 – 2D, 40 – 41 00 – 7F	ARP SF6 Assign Type	off, Preset 0001 ... 7981, User 001 ... 256	00 00	off

TOTAL SIZE = 72 48 (HEX)
pp = part number 00 – 03

Address			Size	Data Range (HEX)	Parameter Name	Description	Default (HEX)	Notes
High	Mid	Low						
35	40	00	1	00 – 03	Audio Input Mode	L mono, R mono, L+R mono, stereo	03	Audio In Part (A/D)
		01	1	00 – 7F	Audio Input Part Volume	0 – 127	64	
		02	1	01 – 7F	Audio Input Part Pan	L63 – C – R63	40	
		03	1	00 – 7F	Audio Input Part Reverb Send	0 – 127	0C	
		04	1	00 – 7F	Audio Input Part Chorus Send	0 – 127	00	
		05	1		reserved			
		06	1	00 – 7F	Audio Input Part Dry Level	0 – 127	7F	
		07	1		reserved			

TOTAL SIZE = 8 08 (HEX)

MIDI PARAMETER CHANGE TABLE (SONG/PATTERN COMMON)

Address			Size	Data Range (HEX)	Parameter Name	Description	Default (HEX)	Notes
High	Mid	Low						
36	00	00	1		reserved			
		01	1		reserved			
		02	1		reserved			
		03	1		reserved			
		04	1		reserved			
		05	1		reserved			
		06	1		reserved			
		07	1		reserved			
		08	1		reserved			
		09	1		reserved			
		0A	1		reserved			
		0B	1		reserved			
		0C	1		reserved			
		0D	1		reserved			
		0E	1		reserved			
		0F	1		reserved			
		10	1		reserved			
		11	1		reserved			
		12	1		reserved			
		13	1		reserved			
		14	1		reserved			
		15	1		reserved			
		16	1		reserved			
		17	1		reserved			
		18	1		reserved			
		19	1		reserved			
		1A	1		reserved			
		1B	1		reserved			
		1C	1		reserved			
		1D	1		reserved			
36	00	1E	1	00 - 33	Knob Function Select	bit0-3 KnobUp : 0=Tone1, 1=Tone2, 2=Tone3, 3=Volume/ Pan bit4-7 KnobLo : 0=EQ, 1=Fx, 2=Arp, 3=Volume/Pan	00	
		1F	1		reserved			
		20	1		reserved			
		21	1		reserved			
		22	1		reserved			
		23	1		reserved			
		24	1		reserved			
		25	1		reserved			
		26	1		reserved			
		27	1		reserved			
		28	1		reserved			
		29	1		reserved			
		2A	1		reserved			
		2B	1		reserved			
		2C	1		reserved			
		2D	1		reserved			
		2E	1		reserved			
		2F	1		reserved			
		30	1		reserved			
		31	1		reserved			
		32	1		reserved			
		33	1		reserved			
		34	1		reserved			
		35	1		reserved			
		36	1		reserved			
		37	1		reserved			
		38	1		reserved			
		39	1		reserved			
		3A	1		reserved			
		3B	1		reserved			
		3C	1		reserved			
36	00	3D	1		reserved			
		3E	1		reserved			
		3F	1	00 - 01	Assignable Function 1 Mode	momentary, latch	01	
		40	1	00 - 01	Assignable Function 2 Mode	momentary, latch	01	
		41	1		reserved			
		42	1		reserved			
		43	1		reserved			
		44	1		reserved			
		45	1		reserved			
		46	1		reserved			
		47	1		reserved			
		48	1		reserved			
		49	1		reserved			
		4A	1		reserved			

Address			Size	Data Range (HEX)	Parameter Name	Description	Default (HEX)	Notes	
High	Mid	Low							
			4B	1	01 - 02	A/D Input Insertion Connect Type	ins A>B, ins B>A	01	
			4C	4	00 - 00 00 - 23 00 - 7C 00 - 00	Insertion Part Sw	1st bit6-0: reserved 2nd bit6: reserved 2nd bit5: off, on A/D Part 2nd bit4: reserved 2nd bit3: reserved 2nd bit2: reserved 2nd bit1: off, on Part16 2nd bit0: off, on Part15 3rd bit6: off, on Part14 3rd bit5: off, on Part13 3rd bit4: off, on Part12 3rd bit3: off, on Part11 3rd bit2: off, on Part10 3rd bit1: off, on Part9 3rd bit0: off, on Part8 4th bit6: off, on Part7 4th bit5: off, on Part6 4th bit4: off, on Part5 4th bit3: off, on Part4 4th bit2: off, on Part3 4th bit1: off, on Part2 4th bit0: off, on Part1	00 00 01 7F	Up to eight parts can be turned on simultaneously.

TOTAL SIZE = 80 50 (HEX)

Address			Size	Data Range (HEX)	Parameter Name	Description	Default (HEX)	Notes
High	Mid	Low						
36	30	00	1	00 - 05	ARP SF Select	SF1 - SF6	00	
		01	1		reserved			
		02	2		reserved			
		04	1	00 - 01	ARP Common Switch	off, on	00	
		05	1	00 - 07	ARP Synchro Quantize Value	off, 32th, 16th_Triplet, 16th, 8th_Triplet, 8th, 4th_Triplet, 4th	00	
		06	2	00 - 01 1C - 64	ARP Quantize Strength Offset	-100 ... +100	01 00	
		08	2	00 - 01 1C - 64	ARP Gate Time Rate Offset	-100 ... +100	01 00	
		0A	2	00 - 01 1C - 64	ARP Velocity Rate Offset	-100 ... +100	01 00	
		0C	2	00 - 01 08 - 78	ARP Swing Offset	-120 ... +120	01 00	

TOTAL SIZE = 14 0E (iHEX)

Address			Size	Data Range (HEX)	Parameter Name	Description	Default (HEX)	Notes
High	Mid	Low						
36	01	00	2	00 - 7F 00 - 7F	Reverb Type	Refer to the "Effect Parameter List."	01 00	Rev-X Hall
		02	1	00 - 7F	Preset Number		00	Basic
		03	1		reserved			
		04	2	00 - 7F 00 - 7F	Reverb Parameter 1	Refer to the "Effect Parameter List."		Init value for Rev-X Hall / Basic
		06	2	00 - 7F 00 - 7F	Reverb Parameter 2	:		Init value for Rev-X Hall / Basic
		08	2	00 - 7F 00 - 7F	Reverb Parameter 3	:		Init value for Rev-X Hall / Basic
		0A	2	00 - 7F 00 - 7F	Reverb Parameter 4	:		Init value for Rev-X Hall / Basic
		0C	2	00 - 7F 00 - 7F	Reverb Parameter 5	:		Init value for Rev-X Hall / Basic
		0E	2	00 - 7F 00 - 7F	Reverb Parameter 6	:		Init value for Rev-X Hall / Basic
		10	2	00 - 7F 00 - 7F	Reverb Parameter 7	:		Init value for Rev-X Hall / Basic
		12	2	00 - 7F 00 - 7F	Reverb Parameter 8	:		Init value for Rev-X Hall / Basic
		14	2	00 - 7F 00 - 7F	Reverb Parameter 9	:		Init value for Rev-X Hall / Basic
		16	2	00 - 7F 00 - 7F	Reverb Parameter 10	:		Init value for Rev-X Hall / Basic
		18	2	00 - 7F 00 - 7F	Reverb Parameter 11	:		Init value for Rev-X Hall / Basic
		1A	2	00 - 7F 00 - 7F	Reverb Parameter 12	:		Init value for Rev-X Hall / Basic
		1C	2	00 - 7F 00 - 7F	Reverb Parameter 13	:		Init value for Rev-X Hall / Basic
		1E	2	00 - 7F 00 - 7F	Reverb Parameter 14	:		Init value for Rev-X Hall / Basic
		20	2	00 - 7F 00 - 7F	Reverb Parameter 15	:		Init value for Rev-X Hall / Basic
		22	2	00 - 7F 00 - 7F	Reverb Parameter 16	:		Init value for Rev-X Hall / Basic
		24	1	00 - 7F	Reverb Return	-∞dB...0dB...+6dB (0...96...127)	40	
		25	1	01 - 7F	Reverb Pan	L63...C...R63	40	

TOTAL SIZE = 38 26 (HEX)

Address			Size	Data Range (HEX)	Parameter Name	Description	Default (HEX)	Notes
High	Mid	Low						
36	02	00	2	00 - 7F 00 - 7F	Chorus Type	Refer to the "Effect Parameter List."	03 00	G Chorus
	02	01	1	00 - 7F	Preset Number		00	Basic
	03	01	1		reserved			
	04	2	2	00 - 7F 00 - 7F	Chorus Parameter 1	Refer to the "Effect Parameter List."		Init value for G Chorus / Basic
	06	2	2	00 - 7F 00 - 7F	Chorus Parameter 2	:		Init value for G Chorus / Basic
	08	2	2	00 - 7F 00 - 7F	Chorus Parameter 3	:		Init value for G Chorus / Basic
	0A	2	2	00 - 7F 00 - 7F	Chorus Parameter 4	:		Init value for G Chorus / Basic
	0C	2	2	00 - 7F 00 - 7F	Chorus Parameter 5	:		Init value for G Chorus / Basic
	0E	2	2	00 - 7F 00 - 7F	Chorus Parameter 6	:		Init value for G Chorus / Basic
	10	2	2	00 - 7F 00 - 7F	Chorus Parameter 7	:		Init value for G Chorus / Basic
	12	2	2	00 - 7F 00 - 7F	Chorus Parameter 8	:		Init value for G Chorus / Basic
	14	2	2	00 - 7F 00 - 7F	Chorus Parameter 9	:		Init value for G Chorus / Basic
	16	2	2	00 - 7F 00 - 7F	Chorus Parameter 10	:		Init value for G Chorus / Basic
	18	2	2	00 - 7F 00 - 7F	Chorus Parameter 11	:		Init value for G Chorus / Basic
	1A	2	2	00 - 7F 00 - 7F	Chorus Parameter 12	:		Init value for G Chorus / Basic
	1C	2	2	00 - 7F 00 - 7F	Chorus Parameter 13	:		Init value for G Chorus / Basic
	1E	2	2	00 - 7F 00 - 7F	Chorus Parameter 14	:		Init value for G Chorus / Basic
	20	2	2	00 - 7F 00 - 7F	Chorus Parameter 15	:		Init value for G Chorus / Basic
	22	2	2	00 - 7F 00 - 7F	Chorus Parameter 16	:		Init value for G Chorus / Basic
	24	1	1	00 - 7F	Chorus Return	--dB...0dB...+6dB (0...96...127)	60	
	25	1	1	01 - 7F	Chorus Pan	L63...C...R63	40	
	26	1	1	00 - 7F	Send Chorus To Reverb	--dB...0dB (0...127)	00	
	27	1	1		reserved			

TOTAL SIZE = 40 28 (HEX)

Address			Size	Data Range (HEX)	Parameter Name	Description	Default (HEX)	Notes
High	Mid	Low						
36	03	00	2	00 - 7F 00 - 7F	Insertion A Type	Refer to the "Effect Parameter List."	00 00	For A/D Part
	02	01	1	00 - 7F	Preset Number		00	
	03	01	1		reserved			
	04	2	2	00 - 7F 00 - 7F	Insertion A Parameter 1	Refer to the "Effect Parameter List."	00 00	
	06	2	2	00 - 7F 00 - 7F	Insertion A Parameter 2	:	00 00	
	08	2	2	00 - 7F 00 - 7F	Insertion A Parameter 3	:	00 00	
	0A	2	2	00 - 7F 00 - 7F	Insertion A Parameter 4	:	00 00	
	0C	2	2	00 - 7F 00 - 7F	Insertion A Parameter 5	:	00 00	
	0E	2	2	00 - 7F 00 - 7F	Insertion A Parameter 6	:	00 00	
	10	2	2	00 - 7F 00 - 7F	Insertion A Parameter 7	:	00 00	
	12	2	2	00 - 7F 00 - 7F	Insertion A Parameter 8	:	00 00	
	14	2	2	00 - 7F 00 - 7F	Insertion A Parameter 9	:	00 00	
	16	2	2	00 - 7F 00 - 7F	Insertion A Parameter 10	:	00 00	
	18	2	2	00 - 7F 00 - 7F	Insertion A Parameter 11	:	00 00	
	1A	2	2	00 - 7F 00 - 7F	Insertion A Parameter 12	:	00 00	
	1C	2	2	00 - 7F 00 - 7F	Insertion A Parameter 13	:	00 00	
	1E	2	2	00 - 7F 00 - 7F	Insertion A Parameter 14	:	00 00	
	20	2	2	00 - 7F 00 - 7F	Insertion A Parameter 15	:	00 00	
	22	2	2	00 - 7F 00 - 7F	Insertion A Parameter 16	:	00 00	

TOTAL SIZE = 36 24 (HEX)

Address			Size	Data Range (HEX)	Parameter Name	Description	Default (HEX)	Notes
High	Mid	Low						
36	04	00	2	00 - 7F 00 - 7F	Insertion B Type	Refer to the "Effect Parameter List."	00 00	For A/D Part
	02	01	1	00 - 7F	Preset Number		00	
	03	01	1		reserved			
	04	2	2	00 - 7F 00 - 7F	Insertion B Parameter 1	Refer to the "Effect Parameter List."	00 00	
	06	2	2	00 - 7F 00 - 7F	Insertion B Parameter 2	:	00 00	
	08	2	2	00 - 7F 00 - 7F	Insertion B Parameter 3	:	00 00	
	0A	2	2	00 - 7F 00 - 7F	Insertion B Parameter 4	:	00 00	
	0C	2	2	00 - 7F 00 - 7F	Insertion B Parameter 5	:	00 00	
	0E	2	2	00 - 7F 00 - 7F	Insertion B Parameter 6	:	00 00	
	10	2	2	00 - 7F 00 - 7F	Insertion B Parameter 7	:	00 00	
	12	2	2	00 - 7F 00 - 7F	Insertion B Parameter 8	:	00 00	
	14	2	2	00 - 7F 00 - 7F	Insertion B Parameter 9	:	00 00	
	16	2	2	00 - 7F 00 - 7F	Insertion B Parameter 10	:	00 00	
	18	2	2	00 - 7F 00 - 7F	Insertion B Parameter 11	:	00 00	
	1A	2	2	00 - 7F 00 - 7F	Insertion B Parameter 12	:	00 00	
	1C	2	2	00 - 7F 00 - 7F	Insertion B Parameter 13	:	00 00	
	1E	2	2	00 - 7F 00 - 7F	Insertion B Parameter 14	:	00 00	
	20	2	2	00 - 7F 00 - 7F	Insertion B Parameter 15	:	00 00	
	22	2	2	00 - 7F 00 - 7F	Insertion B Parameter 16	:	00 00	

TOTAL SIZE = 36 24 (HEX)

Address			Size	Data Range (HEX)	Parameter Name	Description	Default (HEX)	Notes
High	Mid	Low						
36	10	00	1	34 - 4C	EQ Low Gain	-12 - +12 [dB]	40	
	01	1	1	04 - 28	EQ Low Frequency	32 - 2000 [Hz]	0C	When setting the EQ shape peaking type, the range is 63Hz - 2.0kHz.
	02	1	1	01 - 78	EQ Low Q	0.1 - 12.0	07	When setting the EQ shape shelving type, this is not available.
	03	1	1	00 - 01	EQ Low Shape	shelv, peak	00	
	04	1	1	34 - 4C	EQ Low-Mid Gain	-12 - +12 [dB]	40	
	05	1	1	0E - 36	EQ Low-Mid Frequency	100 - 10.0 [kHz]	14	
	06	1	1	01 - 78	EQ Low-Mid Q	0.1 - 12.0	07	
	07	1	1		reserved		01	
	08	1	1	34 - 4C	EQ Mid Gain	-12 - +12 [dB]	40	
	09	1	1	0E - 36	EQ Mid Frequency	100 - 10.0 [kHz]	1C	
	0A	1	1	01 - 78	EQ Mid Q	0.1 - 12.0	07	
	0B	1	1		reserved		01	
	0C	1	1	34 - 4C	EQ High-Mid Gain	-12 - +12 [dB]	40	
	0D	1	1	0E - 36	EQ High-Mid Frequency	100 - 10.0 [kHz]	2C	
	0E	1	1	01 - 78	EQ High-Mid Q	0.1 - 12.0	07	
	0F	1	1		reserved		01	
	10	1	1	34 - 4C	EQ High Gain	-12 - +12 [dB]	40	
	11	1	1	1C - 3A	EQ High Frequency	0.5 - 16.0 [kHz]	34	
	12	1	1	01 - 78	EQ High Q	0.1 - 12.0	07	When setting the EQ shape shelving type, this is not available.
	13	1	1	00 - 01	EQ High Shape	shelv, peak	00	

TOTAL SIZE = 20 14 (HEX)

MIDI PARAMETER CHANGE TABLE (SONG/PATTERN PART)

Address			Size	Data Range (HEX)	Parameter Name	Description	Default (HEX)	Notes
High	Mid	Low						
36	11	00	2	00 – 7F 00 – 7F	Master Effect Type	Refer to the "Effect Parameter List."	08 20	Multi Band Comp
		02	1	00 – 7F	Preset Number		00	Basic
		03	1		reserved			
		04	2	00 – 7F 00 – 7F	Master Effect Parameter 1	Refer to the "Effect Parameter List."		Init value for Multi Band Comp / Basic
		06	2	00 – 7F 00 – 7F	Master Effect Parameter 2	:		Init value for Multi Band Comp / Basic
		08	2	00 – 7F 00 – 7F	Master Effect Parameter 3	:		Init value for Multi Band Comp / Basic
		0A	2	00 – 7F 00 – 7F	Master Effect Parameter 4	:		Init value for Multi Band Comp / Basic
		0C	2	00 – 7F 00 – 7F	Master Effect Parameter 5	:		Init value for Multi Band Comp / Basic
		0E	2	00 – 7F 00 – 7F	Master Effect Parameter 6	:		Init value for Multi Band Comp / Basic
		10	2	00 – 7F 00 – 7F	Master Effect Parameter 7	:		Init value for Multi Band Comp / Basic
		12	2	00 – 7F 00 – 7F	Master Effect Parameter 8	:		Init value for Multi Band Comp / Basic
		14	2	00 – 7F 00 – 7F	Master Effect Parameter 9	:		Init value for Multi Band Comp / Basic
		16	2	00 – 7F 00 – 7F	Master Effect Parameter 10	:		Init value for Multi Band Comp / Basic
		18	2	00 – 7F 00 – 7F	Master Effect Parameter 11	:		Init value for Multi Band Comp / Basic
		1A	2	00 – 7F 00 – 7F	Master Effect Parameter 12	:		Init value for Multi Band Comp / Basic
		1C	2	00 – 7F 00 – 7F	Master Effect Parameter 13	:		Init value for Multi Band Comp / Basic
		1E	2	00 – 7F 00 – 7F	Master Effect Parameter 14	:		Init value for Multi Band Comp / Basic
		20	2	00 – 7F 00 – 7F	Master Effect Parameter 15	:		Init value for Multi Band Comp / Basic
		22	2	00 – 7F 00 – 7F	Master Effect Parameter 16	:		Init value for Multi Band Comp / Basic
		24	1	00 – 01	Master Effect Switch	off, on	00	
		25	1		reserved			

TOTAL SIZE = 38 26(HEX)

Address			Size	Data Range (HEX)	Parameter Name	Description	Default (HEX)	Notes
High	Mid	Low						
37	pp	00	1		reserved			
		01	1	00 – 7F	Bank Select MSB	0 – 127	3F	
		02	1	00 – 7F	Bank Select LSB	0 – 127	00	
		03	1	00 – 7F	Program Number	1 – 128	00	
		04	1	00 – 0F, 7F	Receive Channel	1..16, off (7F)		Part No.
		05	1	00 – 01	Mono/Poly	mono, poly	01	
		06	1	01 – 7F	Velocity Limit Low	1 – 127	01	
		07	1	01 – 7F	Velocity Limit High	1 – 127	7F	
		08	1	00 – 7F	Note Limit Low	C-2 – G8	00	
		09	1	00 – 7F	Note Limit High	C-2 – G8	7F	
		0A	1	10 – 58	Pitch Bend Range Upper	-48 – +24	42	
		0B	1	10 – 58	Pitch Bend Range Lower	-48 – +24	3E	
		0C	1	00 – 7F	Velocity Sensitivity Depth	0 – 127	40	
		0D	1	00 – 7F	Velocity Sensitivity Offset	0 – 127	40	
		0E	1	00 – 7F	Volume	0 – 127	64	
		0F	1	01 – 7F	Pan	L63 – C – R63	40	
		10	2	00 – 0F 00 – 0F	Detune	-12.8 – +12.7 [Hz] 1st bit3-0 → bit7-4, 2nd bit3-0 → bit3-0	08 00 (80)	
		12	1	00 – 7F	Reverb Send	0 – 127	0C	
		13	1	00 – 7F	Chorus Send	0 – 127	00	
		14	1		reserved			
		15	1	00 – 7F	Dry Level	0 – 127	7F	
		16	1	28 – 58	Note Shift	-24 – +24 [semitones]	40	
		17	1		reserved			
		18	1	00 – 01	Param. with Voice	off, on	00	
		19	1	00 – 01	Voice with Arp	off, on	00	
		1A	1	00 – 01	Portamento Switch	off, on	00	
		1B	1	00 – 7F	Portamento Time	0 – 127	40	
		1C	1	00 – 01	Portamento Mode	fingered, fulltime	01	
		1D	1		reserved			
		1E	1	00 – 01	USB Audio Output Select	USB 1/2, USB 3/4	01	This is available only when the audio connect mode is set to 2 Stereo Rec mode.
37	pp	1F	1	18 – 7C	Receive PB Receive AT Receive Program Change Receive Bank Select Receive Control Change reserved	bit6: off, on PB bit5: off, on AT bit4: off, on Program Change bit3: off, on Bank Select bit2: off, on Control Change bit1-0: reserved	7C	
		20	1	02 – 6F	Receive FC2 Receive FC1 reserved Receive MW Receive Sustain/Sostenute Receive Pan Receive Volume/Expression	bit6: off, on FC2 bit5: off, on FC1 bit4: reserved bit3: off, on MW bit2: off, on Sustain/ Sostenute bit1: off, on Pan bit0: off, on Volume/ Expression	6F	
		21	1	00 – 7F	Receive Assignable Function 2 Receive Assignable Function 1 Receive Assignable Knob 2 Receive Assignable Knob 1 Receive RB Receive BC Receive FS	bit6: off, on AF2 bit5: off, on AF1 bit4: off, on AKN2 bit3: off, on AKN1 bit2: off, on RB bit1: off, on BC bit0: off, on FS	7F	
37	pp	22	1	00 – 01	Voice Element Pan	off, on	01	
		23	1	00 – 7F	AEG Attack Time	-64 – +63	40	
		24	1	00 – 7F	AEG Decay Time	-64 – +63	40	
		25	1	00 – 7F	AEG Sustain Level	-64 – +63	40	Only for Normal Voice
		26	1	00 – 7F	AEG Release Time	-64 – +63	40	Only for Normal Voice
		27	1	00 – 7F	FEG Attack Time	-64 – +63	40	Only for Normal Voice
		28	1	00 – 7F	FEG Decay Time	-64 – +63	40	Only for Normal Voice
		29	1	00 – 7F	FEG Sustain Level	-64 – +63	40	Only for Normal Voice
		2A	1	00 – 7F	FEG Release Time	-64 – +63	40	Only for Normal Voice
		2B	1	00 – 7F	FEG Depth	-64 – +63	40	Only for Normal Voice
		2C	1		reserved			
		2D	1	00 – 7F	Filter Cutoff Frequency	-64 – +63	40	
		2E	1	00 – 7F	Filter Resonance/Width	-64 – +63	40	

Address			Size	Data Range (HEX)	Parameter Name	Description	Default (HEX)	Notes
High	Mid	Low						
37	pp	2F	1		reserved			
		30	2	00-01 2E-36	EQ Low Frequency	50.1 - 2.00k	00 36	
		32	1	20-60	EQ Low Gain	-32 - +32 (-12.00db +12.00db)	40	
		33	1		reserved			
		34	2	00-01 53-71	EQ Mid Frequency	139.7 - 10.1k	01 0D	
		36	1	20-60	EQ Mid Gain	-32 - +32 (-12.00db +12.00db)	40	
		37	1	00-1F	EQ Mid Q	0 - 31 (0.7 - 10.3)	00	
		38	2	01-01 03-7F	EQ High Frequency	503.8 - 14k	01 67	
		3A	1	20-60	EQ High Gain	-32 - +32 (-12.00db +12.00db)	40	
		3B	1		reserved			
37	pp	3C	1	00-7F	Assignable Knob 1 Value	-64 - +63	40	
		3D	1	00-7F	Assignable Knob 2 Value	-64 - +63	40	

TOTAL SIZE = 62 3E (HEX)
pp = part number 00 - 0F

Address			Size	Data Range (HEX)	Parameter Name	Description	Default (HEX)	Notes
High	Mid	Low						
38	pp	00	1	00-01	ARP Switch	off, on	00	
		01	1	00-01	ARP MIDI Out Switch	off, on	00	
		02	1	00-10	ARP Transmit Channel	1..16, kbd-ch	Part No.	
		03	1	00-01	ARP Play Only	off, on	00	
		04	1	00-01	ARP Fixed SD/BD	off, on	00	
		05	1		reserved			
		06	1	00-01	ARP Loop	off, on	01	
		07	1	00-02	ARP Hold	sync-off, off, on	01	
		08	1	00-06	ARP Unit Multiply	50%, 66%, 75%, 100%, 133%, 150%, 200%	03	
		09	1	00-7F	ARP Note Limit Low	C-2..G8	00	
		0A	1	00-7F	ARP Note Limit High	C-2..G8	7F	
		0B	1	01-7F	ARP Velocity Limit Low	1 - 127	01	
		0C	1	01-7F	ARP Velocity Limit High	1 - 127	7F	
		0D	1	00-04	ARP Key Mode	sort, thru, direct, sort+direct, thru+direct	00	
		0E	1	00-01	ARP Velocity Mode	original, thru	00	
		0F	1	00-01	ARP Change Timing	realtime, measure	01	
		10	1	01-07	ARP Quantize Value	32th, 16th_Triplet, 16th, 8th_Triplet, 8th, 4th_Triplet, 4th	03	
		11	1	00-64	ARP Quantize Strength	0..100%	00	
		12	2	00-01 00-48	ARP Velocity Rate	0..200%	00 64	
		14	2	00-01 00-48	ARP Gate Time Rate	0..200%	00 64	
		16	1		reserved			
		17	1		reserved			
		18	1		reserved			
		19	1		reserved			
		1A	2	00-01 08-78	ARP Swing	-120 ... 0 ... +120	01 00	
		1C	1	00-7F	ARP Accent Velocity Threshold	off, 1 ... 127	40	
		1D	1	00-01	ARP Accent Start Quantize	off, on	01	
		1E	1	3D-43	ARP Octave Range	-3 ... 0 ... +3	40	
		1F	1	36-4A	ARP Output Octave Shift	-10 ... 0 ... +10	40	
		20	1	00-01	ARP Trigger Mode	gate, toggle	00	
		21	1	00-01	ARP Random SFX	off, on	01	
		22	1	00-01	ARP Random SFX Keyon Control	off, on	01	
		23	1	00-7F	ARP Random SFX Velocity Offset	-64 ... 0 ... +63	40	
		24	2	00-01 1C-64	ARP Assign Velocity Rate Offset SF1	-100 ... 0 ... +100	01 00	
		26	2	00-01 1C-64	ARP Assign Gate Time Rate Offset SF1	-100 ... 0 ... +100	01 00	
		28	2	00-01 1C-64	ARP Assign Velocity Rate Offset SF2	-100 ... 0 ... +100	01 00	
		2A	2	00-01 1C-64	ARP Assign Gate Time Rate Offset SF2	-100 ... 0 ... +100	01 00	
		2C	2	00-01 1C-64	ARP Assign Velocity Rate Offset SF3	-100 ... 0 ... +100	01 00	
		2E	2	00-01 1C-64	ARP Assign Gate Time Rate Offset SF3	-100 ... 0 ... +100	01 00	
		30	2	00-01 1C-64	ARP Assign Velocity Rate Offset SF4	-100 ... 0 ... +100	01 00	
		32	2	00-01 1C-64	ARP Assign Gate Time Rate Offset SF4	-100 ... 0 ... +100	01 00	
		34	2	00-01 1C-64	ARP Assign Velocity Rate Offset SF5	-100 ... 0 ... +100	01 00	
		36	2	00-01 1C-64	ARP Assign Gate Time Rate Offset SF5	-100 ... 0 ... +100	01 00	

Address			Size	Data Range (HEX)	Parameter Name	Description	Default (HEX)	Notes
High	Mid	Low						
		38	2	00-01 1C-64	ARP Assign Velocity Rate Offset SF6	-100 ... 0 ... +100	01 00	
		3A	2	00-01 1C-64	ARP Assign Gate Time Rate Offset SF6	-100 ... 0 ... +100	01 00	
		3C	2	00-3E 00-2D, 40-41 00-7F	ARP SF1 Assign Type	off, Preset 0001 ... 7981, User 001 ... 256	05 4A	MA_Pf Arp1
		3E	2	00-3E 00-2D, 40-41 00-7F	ARP SF2 Assign Type	off, Preset 0001 ... 7981, User 001 ... 256	00 00	off
		40	2	00-3E 00-2D, 40-41 00-7F	ARP SF3 Assign Type	off, Preset 0001 ... 7981, User 001 ... 256	00 00	off
		42	2	00-3E 00-2D, 40-41 00-7F	ARP SF4 Assign Type	off, Preset 0001 ... 7981, User 001 ... 256	00 00	off
		44	2	00-3E 00-2D, 40-41 00-7F	ARP SF5 Assign Type	off, Preset 0001 ... 7981, User 001 ... 256	00 00	off
		46	2	00-3E 00-2D, 40-41 00-7F	ARP SF6 Assign Type	off, Preset 0001 ... 7981, User 001 ... 256	00 00	off

TOTAL SIZE = 72 48 (HEX)
pp = part number 00 - 0F

Address			Size	Data Range (HEX)	Parameter Name	Description	Default (HEX)	Notes
High	Mid	Low						
39	40	00	1	00-03	Audio Input Mode	L mono, R mono, L+R mono, stereo	03	Audio In Part (A/D)
		01	1	00-7F	Audio Input Part Volume	0 - 127	64	
		02	1	01-7F	Audio Input Part Pan	L63 - C - R63	40	
		03	1	00-7F	Audio Input Part Reverb Send	0 - 127	0C	
		04	1	00-7F	Audio Input Part Chorus Send	0 - 127	00	
		05	1		reserved			
		06	1	00-7F	Audio Input Part Dry Level	0 - 127	7F	
		07	1		reserved			

TOTAL SIZE = 8 08 (HEX)

MIDI PARAMETER CHANGE TABLE (NORMAL VOICE COMMON)

Address			Size	Data Range (HEX)	Parameter Name	Description	Default (HEX)	Notes
High	Mid	Low						
40	00	00	1	20 - 7E	Voice Name1	32..126 (ASCII)	l	
		01	1	20 - 7E	Voice Name2	32..126 (ASCII)	n	
		02	1	20 - 7E	Voice Name3	32..126 (ASCII)	i	
		03	1	20 - 7E	Voice Name4	32..126 (ASCII)	t	
		04	1	20 - 7E	Voice Name5	32..126 (ASCII)	i	
		05	1	20 - 7E	Voice Name6	32..126 (ASCII)	a	
		06	1	20 - 7E	Voice Name7	32..126 (ASCII)	l	
		07	1	20 - 7E	Voice Name8	32..126 (ASCII)	i	
		08	1	20 - 7E	Voice Name9	32..126 (ASCII)	z	
		09	1	20 - 7E	Voice Name10	32..126 (ASCII)	e	
		0A	1	20 - 7E	Voice Name11	32..126 (ASCII)	d	
		0B	1	20 - 7E	Voice Name12	32..126 (ASCII)		
		0C	1	20 - 7E	Voice Name13	32..126 (ASCII)	V	
		0D	1	20 - 7E	Voice Name14	32..126 (ASCII)	o	
		0E	1	20 - 7E	Voice Name15	32..126 (ASCII)	i	
		0F	1	20 - 7E	Voice Name16	32..126 (ASCII)	c	
		10	1	20 - 7E	Voice Name17	32..126 (ASCII)	e	
		11	1	20 - 7E	Voice Name18	32..126 (ASCII)		
		12	1	20 - 7E	Voice Name19	32..126 (ASCII)		
		13	1	20 - 7E	Voice Name20	32..126 (ASCII)		
		14	1		reserved			
		15	1		reserved			
		16	1		reserved			
		17	1		reserved			
		18	1	00 - 11	Voice Category (Main)	0..17	11 (NoAsg)	
		19	1	00 - 05	Voice Category (Sub)	0..5	00 (-)	
		1A	1		reserved			
		1B	1		reserved			
		1C	1		reserved			
		1D	1		reserved			
40	00	1E	1	00 - 33	Knob Function Select	bit0-3 KnobUp: 0=Tone1, 1=Tone2, 2=Tone3, 3=Volume/ Pan bit4-7 KnobLo: 0=EQ, 1=Fx, 2=Arp, 3=Volume/Pan	00	
		1F	1	01 - 7F	Pan	L63..C..R63	40	
		20	1	28 - 58	Note Shift	-24 - +24 [semitones]	40	
		21	1	00 - 7F	AEG Attack Time	-64..+63	40	
		22	1	00 - 7F	AEG Decay Time	-64..+63	40	
		23	1	00 - 7F	AEG Sustain Level	-64..+63	40	
		24	1	00 - 7F	AEG Release Time	-64..+63	40	
		25	1	00 - 7F	FEG Attack Time	-64..+63	40	
		26	1	00 - 7F	FEG Decay Time	-64..+63	40	
		27	1		reserved			
		28	1	00 - 7F	FEG Release Time	-64..+63	40	
		29	1	00 - 7F	FEG Depth	-64..+63	40	
		2A	1	00 - 7F	Cutoff Frequency	-64..+63	40	
		2B	1	00 - 7F	Resonance	-64..+63	40	
		2C	2	00 - 01 2E - 36	EQ Low Frequency	50.1 - 2.00k	00 36	
		2E	1	20 - 60	EQ Low Gain	-32 - +32 (-12.00db - +12.00db)	40	
		2F	1		reserved			
		30	2	00 - 01 53 - 71	EQ Mid Frequency	139.7 - 10.1k	01 0D	
		32	1	20 - 60	EQ Mid Gain	-32 - +32 (-12.00db - +12.00db)	40	
		33	1	00 - 1F	EQ Mid Q	0 - 31 (0.7 - 10.3)	00	
		34	2	01 - 01 03 - 7F	EQ High Frequency	503.8 - 14.0k	01 67	
		36	1	20 - 60	EQ High Gain	-32 - +32 (-12.00db - +12.00db)	40	
		37	1		reserved			
		38	1	00 - 7F	Assignable Knob 1 Value	-64..+63	40	
		39	1	00 - 7F	Assignable Knob 2 Value	-64..+63	40	
		3A	1	00 - 01	Assignable Function 1 Mode	momentary, latch	01	
		3B	1	00 - 01	Assignable Function 2 Mode	momentary, latch	01	
		3C	1		reserved			
		3D	1		reserved			
		3E	1		reserved			
40	00	3F	1	00 - 7F	Volume	0 - 127	7F	
		40	1	00 - 01	Key Assign Mode	single, multi	01	
		41	1	00 - 01	Mono/Poly Mode	mono, poly	01	
		42	1	00 - 0C	Micro Tuning Scale	Equal, PureMajor, PureMinor, Werckmeister, Kirnberger, Vallot&Yng, 1/4Shift, 1/4Tone, 1/8Tone, Indian, Arabic1, Arabic2, Arabic3	00	
		43	1	00 - 0B	Micro Tuning Root	C-B	00	
		44	1	10 - 58	Pitch Bend Range Upper	-48 - +24 [semitones]	42	

Address			Size	Data Range (HEX)	Parameter Name	Description	Default (HEX)	Notes
High	Mid	Low						
		45	1	10 - 58	Pitch Bend Range Lower	-48 - +24 [semitones]	3E	
		46	1	00 - 01	Portamento Mode	fingered, fulltime	01	
		47	1	00 - 01	Portamento Switch	off, on	00	
		48	1	00 - 7F	Portamento Time	0 - 127	40	
		49	1	00 - 03	Portamento Time Mode	rate1, time1, rate2, time2	00	
		4A	1	00 - 07	Legato Slope	0 - 7	00	
		4B	1	00 - 7F	Reverb Send	0 - 127	0C	
		4C	1	00 - 7F	Chorus Send	0 - 127	00	
40	00	4D	1	00 - 03	Insertion Connect Type	parallel, ins A>B, ins B>A, vocoder	01	
		4E	1		reserved			
		4F	1		reserved			

TOTAL SIZE = 80 50 (HEX)

Address			Size	Data Range (HEX)	Parameter Name	Description	Default (HEX)	Notes
High	Mid	Low						
40	30	00	1	00 - 05	ARP SF Select	SF1 - SF6	00	
		01	1		reserved			
		02	2	00 - 02 05 - 2C	ARP Tempo	5..300	00 5A	
		04	1		reserved			
		05	1		reserved			
		06	2		reserved			
		08	2		reserved			
		0A	2		reserved			
		0C	2		reserved			
		0E	1	00 - 01	ARP Switch	off, on		
		0F	1		reserved			
		10	1		reserved			
		11	1		reserved			
		12	1		reserved			
		13	1		reserved			
		14	1	00 - 01	ARP Loop	off, on	01	
		15	1	00 - 02	ARP Hold	sync-off, off, on	01	
		16	1	00 - 06	ARP Unit Multiply	50%, 66%, 75%, 100%, 133%, 150%, 200%	03	
		17	1	00 - 7F	ARP Note Limit Low	C-2..G8	00	
		18	1	00 - 7F	ARP Note Limit High	C-2..G8	7F	
		19	1	01 - 7F	ARP Velocity Limit Low	1 - 127	01	
		1A	1	01 - 7F	ARP Velocity Limit High	1 - 127	7F	
		1B	1	00 - 04	ARP Key Mode	sort, thru, direct, sort+direct, thru+direct	00	
		1C	1	00 - 01	ARP Velocity Mode	original, thru	00	
		1D	1	00 - 01	ARP Change Timing	realtime, measure	01	
		1E	1	01 - 07	ARP Quantize Value	32th, 16th_Triplet, 16th, 8th_Triplet, 8th, 4th_Triplet, 4th	03	
		1F	1	00 - 64	ARP Quantize Strength	0..100%	00	
		20	2	00 - 01 00 - 48	ARP Velocity Rate	0..200%	00 64	
		22	2	00 - 01 00 - 48	ARP Gate Time Rate	0..200%	00 64	
		24	1		reserved			
		25	1		reserved			
		26	1		reserved		00 64	
		27	1		reserved			
		28	2	00 - 01 08 - 78	ARP Swing	-120 ... 0 ... +120	01 00	
		2A	1	00 - 7F	ARP Accent Velocity Threshold	off, 1 ... 127	40	
		2B	1	00 - 01	ARP Accent Start Quantize	off, on	01	
		2C	1	3D - 43	ARP Octave Range	-3 ... 0 ... +3	40	
		2D	1	36 - 4A	ARP Output Octave Shift	-10 ... 0 ... +10	40	
		2E	1	00 - 01	ARP Trigger Mode	gate, toggle	00	
		2F	1	00 - 01	ARP Random SFX	off, on	01	
		30	1	00 - 01	ARP Random SFX Keyon Control	off, on	01	
		31	1	00 - 7F	ARP Random SFX Velocity Offset	-64 ... 0 ... +63	40	
		32	2	00 - 01 1C - 64	ARP Assign Velocity Rate Offset SF1	-100 ... 0 ... +100	01 00	
		34	2	00 - 01 1C - 64	ARP Assign Gate Time Rate Offset SF1	-100 ... 0 ... +100	01 00	
		36	2	00 - 01 1C - 64	ARP Assign Velocity Rate Offset SF2	-100 ... 0 ... +100	01 00	
		38	2	00 - 01 1C - 64	ARP Assign Gate Time Rate Offset SF2	-100 ... 0 ... +100	01 00	
		3A	2	00 - 01 1C - 64	ARP Assign Velocity Rate Offset SF3	-100 ... 0 ... +100	01 00	
		3C	2	00 - 01 1C - 64	ARP Assign Gate Time Rate Offset SF3	-100 ... 0 ... +100	01 00	

Address			Size	Data Range (HEX)	Parameter Name	Description	Default (HEX)	Notes
High	Mid	Low						
	3E	2	00 - 01 1C - 64	ARP Assign Velocity Rate Offset SF4	-100 ... 0 ... +100	01 00		
	40	2	00 - 01 1C - 64	ARP Assign Gate Time Rate Offset SF4	-100 ... 0 ... +100	01 00		
	42	2	00 - 01 1C - 64	ARP Assign Velocity Rate Offset SF5	-100 ... 0 ... +100	01 00		
	44	2	00 - 01 1C - 64	ARP Assign Gate Time Rate Offset SF5	-100 ... 0 ... +100	01 00		
	46	2	00 - 01 1C - 64	ARP Assign Velocity Rate Offset SF6	-100 ... 0 ... +100	01 00		
	48	2	00 - 01 1C - 64	ARP Assign Gate Time Rate Offset SF6	-100 ... 0 ... +100	01 00		
	4A	2	00 - 3E 00 - 2D, 40 - 41 00 - 7F	ARP SF1 Assign Type	off, Preset 0001 ... 7981, User 001 ... 256	05 4A	MA_Pf Arp1	
	4C	2	00 - 3E 00 - 2D, 40 - 41 00 - 7F	ARP SF2 Assign Type	off, Preset 0001 ... 7981, User 001 ... 256	00 00	off	
	4E	2	00 - 3E 00 - 2D, 40 - 41 00 - 7F	ARP SF3 Assign Type	off, Preset 0001 ... 7981, User 001 ... 256	00 00	off	
	50	2	00 - 3E 00 - 2D, 40 - 41 00 - 7F	ARP SF4 Assign Type	off, Preset 0001 ... 7981, User 001 ... 256	00 00	off	
	52	2	00 - 3E 00 - 2D, 40 - 41 00 - 7F	ARP SF5 Assign Type	off, Preset 0001 ... 7981, User 001 ... 256	00 00	off	
	54	2	00 - 3E 00 - 2D, 40 - 41 00 - 7F	ARP SF6 Assign Type	off, Preset 0001 ... 7981, User 001 ... 256	00 00	off	

TOTAL SIZE = 86 56 (HEX)

Address			Size	Data Range (HEX)	Parameter Name	Description	Default (HEX)	Notes
High	Mid	Low						
40	01	00	2	00 - 7F 00 - 7F	Reverb Type	Refer to the "Effect Parameter List."	01 00	Rev-X Hall
	02	1	00 - 7F	Preset Number		00	Basic	
	03	1	reserved					
	04	2	00 - 7F 00 - 7F	Reverb Parameter 1	Refer to the "Effect Parameter List."			Init value for Rev-X Hall / Basic
	06	2	00 - 7F 00 - 7F	Reverb Parameter 2	:			Init value for Rev-X Hall / Basic
	08	2	00 - 7F 00 - 7F	Reverb Parameter 3	:			Init value for Rev-X Hall / Basic
	0A	2	00 - 7F 00 - 7F	Reverb Parameter 4	:			Init value for Rev-X Hall / Basic
	0C	2	00 - 7F 00 - 7F	Reverb Parameter 5	:			Init value for Rev-X Hall / Basic
	0E	2	00 - 7F 00 - 7F	Reverb Parameter 6	:			Init value for Rev-X Hall / Basic
	10	2	00 - 7F 00 - 7F	Reverb Parameter 7	:			Init value for Rev-X Hall / Basic
	12	2	00 - 7F 00 - 7F	Reverb Parameter 8	:			Init value for Rev-X Hall / Basic
	14	2	00 - 7F 00 - 7F	Reverb Parameter 9	:			Init value for Rev-X Hall / Basic
	16	2	00 - 7F 00 - 7F	Reverb Parameter 10	:			Init value for Rev-X Hall / Basic
	18	2	00 - 7F 00 - 7F	Reverb Parameter 11	:			Init value for Rev-X Hall / Basic
	1A	2	00 - 7F 00 - 7F	Reverb Parameter 12	:			Init value for Rev-X Hall / Basic
	1C	2	00 - 7F 00 - 7F	Reverb Parameter 13	:			Init value for Rev-X Hall / Basic
	1E	2	00 - 7F 00 - 7F	Reverb Parameter 14	:			Init value for Rev-X Hall / Basic
	20	2	00 - 7F 00 - 7F	Reverb Parameter 15	:			Init value for Rev-X Hall / Basic
	22	2	00 - 7F 00 - 7F	Reverb Parameter 16	:			Init value for Rev-X Hall / Basic
	24	1	00 - 7F	Reverb Return	---dB...0dB...+6dB (0...96...127)	40		
	25	1	01 - 7F	Reverb Pan	L63...C...R63	40		

TOTAL SIZE = 38 26 (HEX)

Address			Size	Data Range (HEX)	Parameter Name	Description	Default (HEX)	Notes
High	Mid	Low						
40	02	00	2	00 - 7F 00 - 7F	Chorus Type	Refer to the "Effect Parameter List."	03 00	G Chorus
	02	1	00 - 7F	Preset Number		00	Basic	
	03	1	reserved					
	04	2	00 - 7F 00 - 7F	Chorus Parameter 1	Refer to the "Effect Parameter List."			Init value for G Chorus / Basic
	06	2	00 - 7F 00 - 7F	Chorus Parameter 2	:			Init value for G Chorus / Basic
	08	2	00 - 7F 00 - 7F	Chorus Parameter 3	:			Init value for G Chorus / Basic
	0A	2	00 - 7F 00 - 7F	Chorus Parameter 4	:			Init value for G Chorus / Basic
	0C	2	00 - 7F 00 - 7F	Chorus Parameter 5	:			Init value for G Chorus / Basic
	0E	2	00 - 7F 00 - 7F	Chorus Parameter 6	:			Init value for G Chorus / Basic
	10	2	00 - 7F 00 - 7F	Chorus Parameter 7	:			Init value for G Chorus / Basic
	12	2	00 - 7F 00 - 7F	Chorus Parameter 8	:			Init value for G Chorus / Basic
	14	2	00 - 7F 00 - 7F	Chorus Parameter 9	:			Init value for G Chorus / Basic
	16	2	00 - 7F 00 - 7F	Chorus Parameter 10	:			Init value for G Chorus / Basic
	18	2	00 - 7F 00 - 7F	Chorus Parameter 11	:			Init value for G Chorus / Basic
	1A	2	00 - 7F 00 - 7F	Chorus Parameter 12	:			Init value for G Chorus / Basic
	1C	2	00 - 7F 00 - 7F	Chorus Parameter 13	:			Init value for G Chorus / Basic
	1E	2	00 - 7F 00 - 7F	Chorus Parameter 14	:			Init value for G Chorus / Basic
	20	2	00 - 7F 00 - 7F	Chorus Parameter 15	:			Init value for G Chorus / Basic
	22	2	00 - 7F 00 - 7F	Chorus Parameter 16	:			Init value for G Chorus / Basic
	24	1	00 - 7F	Chorus Return	---dB...0dB...+6dB (0...96...127)	60		
	25	1	01 - 7F	Chorus Pan	L63...C...R63	40		
	26	1	00 - 7F	Send Chorus To Reverb	---dB...0dB (0...127)	00		
	27	1	reserved					

TOTAL SIZE = 40 28 (HEX)

Address			Size	Data Range (HEX)	Parameter Name	Description	Default (HEX)	Notes
High	Mid	Low						
40	03	00	2	00 - 7F 00 - 7F	Insertion A Type	Refer to the "Effect Parameter List."	00 00	
	02	1	00 - 7F	Preset Number		00		
	03	1	reserved					
	04	2	00 - 7F 00 - 7F	Insertion A Parameter 1	Refer to the "Effect Parameter List."	00 00		
	06	2	00 - 7F 00 - 7F	Insertion A Parameter 2	:	00 00		
	08	2	00 - 7F 00 - 7F	Insertion A Parameter 3	:	00 00		
	0A	2	00 - 7F 00 - 7F	Insertion A Parameter 4	:	00 00		
	0C	2	00 - 7F 00 - 7F	Insertion A Parameter 5	:	00 00		
	0E	2	00 - 7F 00 - 7F	Insertion A Parameter 6	:	00 00		
	10	2	00 - 7F 00 - 7F	Insertion A Parameter 7	:	00 00		
	12	2	00 - 7F 00 - 7F	Insertion A Parameter 8	:	00 00		
	14	2	00 - 7F 00 - 7F	Insertion A Parameter 9	:	00 00		
	16	2	00 - 7F 00 - 7F	Insertion A Parameter 10	:	00 00		
	18	2	00 - 7F 00 - 7F	Insertion A Parameter 11	:	00 00		
	1A	2	00 - 7F 00 - 7F	Insertion A Parameter 12	:	00 00		
	1C	2	00 - 7F 00 - 7F	Insertion A Parameter 13	:	00 00		
	1E	2	00 - 7F 00 - 7F	Insertion A Parameter 14	:	00 00		
	20	2	00 - 7F 00 - 7F	Insertion A Parameter 15	:	00 00		
	22	2	00 - 7F 00 - 7F	Insertion A Parameter 16	:	00 00		

TOTAL SIZE = 36 24 (HEX)

Address			Size	Data Range (HEX)	Parameter Name	Description	Default (HEX)	Notes
High	Mid	Low						
40	04	00	2	00-7F 00-7F	Insertion B Type	Refer to the "Effect Parameter List."	00 00	
		02	1	00-7F	Preset Number		00	
		03	1		reserved			
		04	2	00-7F 00-7F	Insertion B Parameter 1	Refer to the "Effect Parameter List."	00 00	
		06	2	00-7F 00-7F	Insertion B Parameter 2	:	00 00	
		08	2	00-7F 00-7F	Insertion B Parameter 3	:	00 00	
		0A	2	00-7F 00-7F	Insertion B Parameter 4	:	00 00	
		0C	2	00-7F 00-7F	Insertion B Parameter 5	:	00 00	
		0E	2	00-7F 00-7F	Insertion B Parameter 6	:	00 00	
		10	2	00-7F 00-7F	Insertion B Parameter 7	:	00 00	
		12	2	00-7F 00-7F	Insertion B Parameter 8	:	00 00	
		14	2	00-7F 00-7F	Insertion B Parameter 9	:	00 00	
		16	2	00-7F 00-7F	Insertion B Parameter 10	:	00 00	
		18	2	00-7F 00-7F	Insertion B Parameter 11	:	00 00	
		1A	2	00-7F 00-7F	Insertion B Parameter 12	:	00 00	
		1C	2	00-7F 00-7F	Insertion B Parameter 13	:	00 00	
		1E	2	00-7F 00-7F	Insertion B Parameter 14	:	00 00	
		20	2	00-7F 00-7F	Insertion B Parameter 15	:	00 00	
		22	2	00-7F 00-7F	Insertion B Parameter 16	:	00 00	

TOTAL SIZE = 36 24 (HEX)

Address			Size	Data Range (HEX)	Parameter Name	Description	Default (HEX)	Notes
High	Mid	Low						
40	05	00	2	00-7F 00-7F	Insertion L Type	Refer to the "Effect Parameter List."	00 00	
		02	1	00-7F	Preset Number		00	
		03	1		reserved			
		04	2	00-7F 00-7F	Insertion L Parameter 1	Refer to the "Effect Parameter List."	00 00	
		06	2	00-7F 00-7F	Insertion L Parameter 2	:	00 00	
		08	2	00-7F 00-7F	Insertion L Parameter 3	:	00 00	
		0A	2	00-7F 00-7F	Insertion L Parameter 4	:	00 00	
		0C	2	00-7F 00-7F	Insertion L Parameter 5	:	00 00	
		0E	2	00-7F 00-7F	Insertion L Parameter 6	:	00 00	
		10	2	00-7F 00-7F	Insertion L Parameter 7	:	00 00	
		12	2	00-7F 00-7F	Insertion L Parameter 8	:	00 00	
		14	2	00-7F 00-7F	Insertion L Parameter 9	:	00 00	
		16	2	00-7F 00-7F	Insertion L Parameter 10	:	00 00	
		18	2	00-7F 00-7F	Insertion L Parameter 11	:	00 00	
		1A	2	00-7F 00-7F	Insertion L Parameter 12	:	00 00	
		1C	2	00-7F 00-7F	Insertion L Parameter 13	:	00 00	
		1E	2	00-7F 00-7F	Insertion L Parameter 14	:	00 00	
		20	2	00-7F 00-7F	Insertion L Parameter 15	:	00 00	
		22	2	00-7F 00-7F	Insertion L Parameter 16	:	00 00	
		24	2	00-7F 00-7F	Insertion L Parameter 17	:	00 00	
		26	2	00-7F 00-7F	Insertion L Parameter 18	:	00 00	
		28	2	00-7F 00-7F	Insertion L Parameter 19	:	00 00	
		2A	2	00-7F 00-7F	Insertion L Parameter 20	:	00 00	
		2C	2	00-7F 00-7F	Insertion L Parameter 21	:	00 00	
		2E	2	00-7F 00-7F	Insertion L Parameter 22	:	00 00	
		30	2	00-7F 00-7F	Insertion L Parameter 23	:	00 00	
		32	2	00-7F 00-7F	Insertion L Parameter 24	:	00 00	

Address			Size	Data Range (HEX)	Parameter Name	Description	Default (HEX)	Notes
High	Mid	Low						
		34	2	00-7F 00-7F	Insertion L Parameter 25	:	00 00	
		36	2	00-7F 00-7F	Insertion L Parameter 26	:	00 00	
		38	2	00-7F 00-7F	Insertion L Parameter 27	:	00 00	
		3A	2	00-7F 00-7F	Insertion L Parameter 28	:	00 00	
		3C	2	00-7F 00-7F	Insertion L Parameter 29	:	00 00	
		3E	2	00-7F 00-7F	Insertion L Parameter 30	:	00 00	
		40	2	00-7F 00-7F	Insertion L Parameter 31	:	00 00	
		42	2	00-7F 00-7F	Insertion L Parameter 32	:	00 00	

TOTAL SIZE = 68 44 (HEX)

Address			Size	Data Range (HEX)	Parameter Name	Description	Default (HEX)	Notes
High	Mid	Low						
40	06	00	1	00-7F	Controller Set1 Depth	-64 +63	40	
		01	1	00-0E	Controller Set1 Source	0: PB, 1: MW, 3: AT, 4: FC, 5: FS, 6: RB, 7: BC, 8: AKN1, 9: AKN2, 12: FC2, 13: ASW1, 14: ASW2	01	
		02	2	00-00 00-65	Controller Set1 Destination	0-101 Refer to the "Control List."	00 00	
		04	1	00-7F	Controller Set2 Depth	-64 +63	40	
		05	1	00-0E	Controller Set2 Source	0: PB, 1: MW, 3: AT, 4: FC, 5: FS, 6: RB, 7: BC, 8: AKN1, 9: AKN2, 12: FC2, 13: ASW1, 14: ASW2	01	
		06	2	00-00 00-65	Controller Set2 Destination	0-101 Refer to the "Control List."	00 00	
		08	1	00-7F	Controller Set3 Depth	-64 +63	40	
		09	1	00-0E	Controller Set3 Source	0: PB, 1: MW, 3: AT, 4: FC, 5: FS, 6: RB, 7: BC, 8: AKN1, 9: AKN2, 12: FC2, 13: ASW1, 14: ASW2	01	
		0A	2	00-00 00-65	Controller Set3 Destination	0-101 Refer to the "Control List."	00 00	
		0C	1	00-7F	Controller Set4 Depth	-64 +63	40	
		0D	1	00-0E	Controller Set4 Source	0: PB, 1: MW, 3: AT, 4: FC, 5: FS, 6: RB, 7: BC, 8: AKN1, 9: AKN2, 12: FC2, 13: ASW1, 14: ASW2	08	
		0E	2	00-00 00-65	Controller Set4 Destination	0-101 Refer to the "Control List."	00 00	
		10	1	00-7F	Controller Set5 Depth	-64 +63	40	
		11	1	00-0E	Controller Set5 Source	0: PB, 1: MW, 3: AT, 4: FC, 5: FS, 6: RB, 7: BC, 8: AKN1, 9: AKN2, 12: FC2, 13: ASW1, 14: ASW2	09	
		12	2	00-00 00-65	Controller Set5 Destination	0-101 Refer to the "Control List."	00 00	
		14	1	00-7F	Controller Set6 Depth	-64 +63	40	
		15	1	00-0E	Controller Set6 Source	0: PB, 1: MW, 3: AT, 4: FC, 5: FS, 6: RB, 7: BC, 8: AKN1, 9: AKN2, 12: FC2, 13: ASW1, 14: ASW2	03	
		16	2	00-00 00-65	Controller Set6 Destination	0-101 Refer to the "Control List."	00 00	
40	06	18	1	00-05	LFO Phase	0, 90, 120, 180, 240, 270	00	
		19	1	00-0C	LFO Wave	tri, tri+, sawup, sawdwn, squ1/4, squ1/3, squ, squ2/3, squ3/4, trpzd, S/H1, S/H2, user	00	
		1A	1	00-3F	LFO Speed	0-63	20	This is available only when Tempo Sync is set to off.
		1B	1	05-18	LFO Tempo Speed	16th, 8th/3, 16th., 8th, 4th/3, 8th., 4th, 2th/3, 4th., 2nd, Whole/3, 2nd., 4thX4, 4thX5, 4thX6, 4thX7, 4thX8, 4thX16, 4thX32, 4thX64	0B	This is available only when Tempo Sync is set to off.
		1C	1	00-01	LFO Tempo Sync	off, on	00	
		1D	1	00-7F	LFO Delay Time	0-127	00	
		1E	1	00-7F	LFO Fade In Time	0-127	00	
		1F	1	00-7F	LFO Hold Time	0-126, hold	7F	

**MIDI PARAMETER CHANGE TABLE
(NORMAL VOICE ELEMENT)**

Address			Size	Data Range (HEX)	Parameter Name	Description	Default (HEX)	Notes
High	Mid	Low						
		20	1	00-7F	LFO Fade Out Time	0-127	40	
		21	1	00-02	LFO Key On Reset	off, each-on, 1st-on	02	
		22	1	00-01	LFO Play Mode	loop, one shot	00	
		23	1	00-7F	LFO Set 1 Depth	0-127	00	
		24	1	00-45	LFO Set 1 Destination	Refer to the "Control List."	02	
		25	1	00-7F	LFO Set 2 Depth	0-127	00	
		26	1	00-45	LFO Set 2 Destination	Refer to the "Control List."	04	
		27	1	00-7F	LFO Set 3 Depth	0-127	00	
		28	1	00-45	LFO Set 3 Destination	Refer to the "Control List."	04	
		29	1	00-06	User Wave Total Step	2, 3, 4, 6, 8, 12, 16	06	
		2A	1	00-03	User Wave Slope	off, up, down, up&down	00	
		2B	1	00-7F	User Wave Step Value1	0-127	40	
		2C	1	00-7F	User Wave Step Value2	0-127	40	
		2D	1	00-7F	User Wave Step Value3	0-127	40	
		2E	1	00-7F	User Wave Step Value4	0-127	40	
		2F	1	00-7F	User Wave Step Value5	0-127	40	
		30	1	00-7F	User Wave Step Value6	0-127	40	
		31	1	00-7F	User Wave Step Value7	0-127	40	
		32	1	00-7F	User Wave Step Value8	0-127	40	
		33	1	00-7F	User Wave Step Value9	0-127	40	
		34	1	00-7F	User Wave Step Value10	0-127	40	
		35	1	00-7F	User Wave Step Value11	0-127	40	
		36	1	00-7F	User Wave Step Value12	0-127	40	
		37	1	00-7F	User Wave Step Value13	0-127	40	
		38	1	00-7F	User Wave Step Value14	0-127	40	
		39	1	00-7F	User Wave Step Value15	0-127	40	
		3A	1	00-7F	User Wave Step Value16	0-127	40	
		3B	1	00-7F	LFO Random Speed Depth	0-127	00	This is available only when Tempo Sync is set to off.

TOTAL SIZE = 60 3C (HEX)

Address			Size	Data Range (HEX)	Parameter Name	Description	Default (HEX)	Notes
High	Mid	Low						
41	ee	00	1	00-01	Element Switch	off, on	01 (only EL1)	
		01	1	00-01	Wave Select	0=preset, 1=user	00	
		02	2	00-1F 01-09	Wave Number	1-3977	00 01	
		04	1	00-07	Element Group Number	1-8	00	
		05	1	01-7F	Pan	L63-C-R63	40	
		06	1	00-7F	Random Pan Depth	0-127	00	
		07	1	00-7F	Alternate Pan Depth	L64-0-R63	40	
		08	1	00-7F	Scaling Pan Depth	-64-+63	40	
		09	1	00-07	XA Control	normal, legato, key off sound, wave cycle, wave random, all AF off, AF 1 on, AF 2 on	00	
		0A	1	00-7F	Note Limit Low	0-127	00	
		0B	1	00-7F	Note Limit High	0-127	7F	
		0C	1	01-7F	Velocity Limit Low	1-127	01	
		0D	1	01-7F	Velocity Limit High	1-127	7F	
		0E	1	00-7F	Velocity Cross Fade	0-127	00	
		0F	1	00-7F	Key On Delay	0-127	00	This is available only when Tempo Sync is set to off.
		10	1	00-01	Key On Delay Tempo Sync	off, on	00	
		11	1	00-02	Insertion Effect	thru, insA, insB	01	
		12	2	00-00 00-3F	Controller Set Element Sw	1st bit6-0: reserved 2nd bit6: reserved 2nd bit5: off, on set6 2nd bit4: off, on set5 2nd bit3: off, on set4 2nd bit2: off, on set3 2nd bit1: off, on set2 2nd bit0: off, on set1	00 3F	
		14	2	00-00 00-07	LFO Set Element Sw	1st bit6-0: reserved 2nd bit6-3: reserved 2nd bit2: off, on box3 2nd bit1: off, on box2 2nd bit0: off, on box1	00 07	
		16	1	05-15	Key On Delay Tempo	16th, 8th/3, 16th., 8th, 4th/3, 8th., 4th, 2th/3, 4th., 2nd, Whole/3, 2nd., 4thX4, 4thX5, 4thX6, 4thX7, 4thX8	0B	This is available only when Tempo Sync is set to off.
		17	1	00-01	Half Damper Switch	off, on	00	
		18	1		reserved			
		19	1		reserved			
41	ee	1A	1	00-7F	Element Level	0-127	7F	
		1B	1	00-7F	Level Velocity Sensitivity	-64-+63	40	
		1C	1	00-7F	Level Velocity Sensitivity Offset	0-127	00	
		1D	1	00-04	Level Velocity Sensitivity Curve	00-04 P00000	03	
		1E	1	00-7F	AEG Attack Time	0-127	00	
		1F	1	00-7F	AEG Decay1 Time	0-127	40	
		20	1	00-7F	AEG Decay2 Time	0-127	40	
		21	1	00-7F	Half Damper Time	0-127	7F	
		22	1	00-7F	AEG Release Time	0-127	32	
		23	1	00-7F	AEG Init Level	0-127	00	
		24	1	00-7F	AEG Attack Level	0-127	7F	
		25	1	00-7F	AEG Decay1 Level	0-127	7F	
		26	1	00-7F	AEG Decay2 Level	0-127	7F	
		27	1		reserved			
		28	1	00-04	AEG Time Velocity Segment	attack, atk+dcy, decay, atk+rls, all	04	
		29	1	00-7F	AEG Time Velocity Sensitivity	-64-+63	40	
		2A	1	00-7F	AEG Time Key Follow Sensitivity	-64-+63	40	
		2B	1	00-7F	AEG Time Key Follow Center Key	C-2-G8	18	
		2C	1	00-7C	Level Scaling Break Point 1	C-2-E8	24	BP1<BP2<BP3<BP4
		2D	1	01-7D	Level Scaling Break Point 2	C#2-F8	30	BP1<BP2<BP3<BP4
		2E	1	02-7E	Level Scaling Break Point 3	D-2-F#8	3C	BP1<BP2<BP3<BP4
		2F	1	03-7F	Level Scaling Break Point 4	D#2-G8	48	BP1<BP2<BP3<BP4
		30	2	00-01 00-7F	Level Scaling Offset 1	-128-+127	01 00	
		32	2	00-01 00-7F	Level Scaling Offset 2	-128-+127	01 00	
		34	2	00-01 00-7F	Level Scaling Offset 3	-128-+127	01 00	
		36	2	00-01 00-7F	Level Scaling Offset 4	-128-+127	01 00	
		38	1	00-7F	Level Key Follow Sensitivity	-200%-+200%	40	
		39	1	00-7F	AEG Time Key Follow Sensitivity Release Adjustment	-64-+63	40	
		3A	1	10-70	Coarse Tune	-48-+48	40	

Address			Size	Data Range (HEX)	Parameter Name	Description	Default (HEX)	Notes
High	Mid	Low						
		3B	1	00 - 7F	Fine Tune	-64 - +63	40	
		3C	1	00 - 7F	Pitch Velocity Sensitivity	-64 - +63	40	
		3D	1	00 - 7F	Random Pitch Depth	0 - 127	00	
		3E	1	00 - 7F	Pitch Key Follow Sensitivity	-200% - +200%	60	
		3F	1	00 - 7F	Pitch Key Follow Sensitivity Center Key	C-2 - G8	3C	
		40	1	00 - 7F	Pitch Fine Scaling Sensitivity	-64 - +63	40	
		41	1	00 - 7F	PEG Hold Time	0 - 127	00	
		42	1	00 - 7F	PEG Attack Time	0 - 127	28	
		43	1	00 - 7F	PEG Decay1 Time	0 - 127	40	
		44	1	00 - 7F	PEG Decay2 Time	0 - 127	40	
		45	1	00 - 7F	PEG Release Time	0 - 127	40	
		46	2	00 - 01 00 - 7F	PEG Hold Level	-128 - +127 (-4800 - +4800 [cent])	01 00	
		48	2	00 - 01 00 - 7F	PEG Attack Level	-128 - +127 (-4800 - +4800 [cent])	01 00	
		4A	2	00 - 01 00 - 7F	PEG Decay1 Level	-128 - +127 (-4800 - +4800 [cent])	01 00	
		4C	2	00 - 01 00 - 7F	PEG Decay2 Level	-128 - +127 (-4800 - +4800 [cent])	01 00	
		4E	2	00 - 01 00 - 7F	PEG Release Level	-128 - +127 (-4800 - +4800 [cent])	01 00	
		50	1	00 - 7F	PEG Depth	-64 - +63	54	
		51	1	00 - 04	PEG Time Velocity Sensitivity Segment	attack, atk+dcy, decay, atk+rls, all	04	
		52	1	00 - 7F	PEG Time Velocity Sensitivity	-64 - +63	40	
		53	1	00 - 7F	PEG Depth Velocity Sensitivity	-64 - +63	40	
		54	1	00 - 04	PEG Depth Velocity Sensitivity Curve	00 - 04 [0][0][0][0]	02	
		55	1	00 - 7F	PEG Time Key Follow Sensitivity	-64 - +63	40	
		56	1	00 - 7F	PEG Time Key Follow Sensitivity Center Key	C-2 - G8	3C	
		57	1		reserved			

TOTAL SIZE = 88 58 (HEX)

ee = element number 00 - 07

Address			Size	Data Range (HEX)	Parameter Name	Description	Default (HEX)	Notes
High	Mid	Low						
42	ee	00	1	00 - 15	Filter Type	LPF24D, LPF24A, LPF18, LPF18s, LPF12+HPF12, LPF6+HPF12, HPF24D, HPF12, BPF12D, BPFw, BPF6, BEF12, BEF6, DualLPF, DualHPF, DualBPF, DualBEF, LPF12+BPF6, thru	04	
		01	1		reserved			
		02	2	00 - 01 00 - 7F	Filter Cutoff Frequency	0 - 255	01 20	
		04	1	00 - 7F	Filter Cutoff Velocity Sensitivity	-64 - +63	40	
		05	1	00 - 7F	Filter Resonance/Width/ Band	0 - 127	00	
		06	1	00 - 7F	Filter Resonance Velocity Sensitivity	-64 - +63	40	
		07	1		reserved			
		08	2	00 - 01 00 - 7F	HPF Cutoff Frequency	0 - 255	00 00	
		0A	2	00 - 01 00 - 7F	Distance	-128 - +127 (available only when the dual type filter is set.)	01 00	
		0C	2	00 - 01 00 - 7F	Filter Gain	0 - 255	01 66	
		0E	1	00 - 7F	FEG Hold Time	0 - 127	00	
		0F	1	00 - 7F	FEG Attack Time	0 - 127	00	
		10	1	00 - 7F	FEG Decay1 Time	0 - 127	40	
		11	1	00 - 7F	FEG Decay2 Time	0 - 127	40	
		12	1	00 - 7F	FEG Release Time	0 - 127	50	
		13	1		reserved			
		14	2	00 - 01 00 - 7F	FEG Hold Level	-128 - +127 (-9600 - +9600 [cent])	01 00	
		16	2	00 - 01 00 - 7F	FEG Attack Level	-128 - +127 (-9600 - +9600 [cent])	01 7F	
		18	2	00 - 01 00 - 7F	FEG Decay1 Level	-128 - +127 (-9600 - +9600 [cent])	01 7F	
		1A	2	00 - 01 00 - 7F	FEG Decay2 Level	-128 - +127 (-9600 - +9600 [cent])	01 7F	
		1C	2	00 - 01 00 - 7F	FEG Release Level	-128 - +127 (-9600 - +9600 [cent])	01 00	
		1E	1	00 - 7F	FEG Depth	-64 - +63	68	
		1F	1	00 - 04	FEG Time Velocity Sensitivity Segment	attack, atk+dcy, decay, atk+rls, all	04	
		20	1	00 - 7F	FEG Time Velocity Sensitivity	-64 - +63	40	
		21	1	00 - 7F	FEG Depth Velocity Sensitivity	-64 - +63	40	

Address			Size	Data Range (HEX)	Parameter Name	Description	Default (HEX)	Notes
High	Mid	Low						
		22	1	00 - 04	FEG Depth Velocity Sensitivity Curve	00 - 04 [0][0][0][0]	02	
		23	1	00 - 7F	FEG Time Key Follow Sensitivity	-64 - +63	40	
		24	1	00 - 7F	FEG Time Key Follow Sensitivity Center Key	C-2 - G8	18	
		25	1	00 - 7C	Filter Cutoff Scaling Break Point 1	C-2 - E8	24	BP1<BP2<BP3<BP4
		26	1	01 - 7D	Filter Cutoff Scaling Break Point 2	C#-2 - F8	30	BP1<BP2<BP3<BP4
		27	1	02 - 7E	Filter Cutoff Scaling Break Point 3	D-2 - F#8	3C	BP1<BP2<BP3<BP4
		28	1	03 - 7F	Filter Cutoff Scaling Break Point 4	D#-2 - G8	48	BP1<BP2<BP3<BP4
		29	1		reserved			
		2A	2	00 - 01 00 - 7F	Filter Cutoff Scaling Offset 1	-128 - +127	01 00	
		2C	2	00 - 01 00 - 7F	Filter Cutoff Scaling Offset 2	-128 - +127	01 00	
		2E	2	00 - 01 00 - 7F	Filter Cutoff Scaling Offset 3	-128 - +127	01 00	
		30	2	00 - 01 00 - 7F	Filter Cutoff Scaling Offset 4	-128 - +127	01 00	
		32	1	00 - 7F	Filter Cutoff Key Follow Sensitivity	-200% - +200%	4A	
		33	1	00 - 7F	HPF Cutoff Key Follow Sensitivity	-200% - +200%	40	
42	ee	34	1	00 - 05	EQ Type	2 Band, PEQ, Boost6, Boost12, Boost18, thru	00	
		35	1	00 - 1F	EQ Q	0 - 31 (0.7 - 10.3)	00	
		36	2	00 - 01 2E - 7B	EQ 1 Frequency	2 Band: 46-182, PEQ: 83-251	00 36	
		38	1	20 - 60	EQ 1 Gain	-32 - +32	40	
		39	1		reserved			
		3A	2	01 - 01 03 - 71	EQ 2 Frequency	2 Band: 131-241	01 67	
		3C	1	20 - 60	EQ 2 Gain	-32 - +32	40	
		3D	1		reserved			
42	ee	3E	1	00 - 02	LFO Wave	saw, tri, squ	01	
		3F	1	00 - 01	LFO Key On Reset	off, on	01	
		40	1	00 - 7F	LFO Key On Delay Time	0 - 127	00	
		41	1	00 - 3F	LFO Speed	0 - 63	26	
		42	1	00 - 7F	LFO AMod Depth	0 - 127	00	
		43	1	00 - 7F	LFO PMod Depth	0 - 127	00	
		44	1	00 - 7F	LFO FMod Depth	0 - 127	00	
		45	1	00 - 7F	LFO Fade In Time	0 - 127	00	
42	ee	46	1	00 - 05	Common LFO Phase Offset	+0, +90, +120, +180, +240, +270	00	
		47	1	00 - 7F	Common LFO Box1 Depth Ratio	0 - 127	7F	
		48	1	00 - 7F	Common LFO Box2 Depth Ratio	0 - 127	7F	
		49	1	00 - 7F	Common LFO Box3 Depth Ratio	0 - 127	7F	

TOTAL SIZE = 74 4A (HEX)

ee = element number 00 - 07

MIDI PARAMETER CHANGE TABLE (DRUM VOICE COMMON)

Address			Size	Data Range (HEX)	Parameter Name	Description	Default (HEX)	Notes
High	Mid	Low						
46	00	00	1	20-7E	Voice Name1	32..126 (ASCII)	l	
		01	1	20-7E	Voice Name2	32..126 (ASCII)	n	
		02	1	20-7E	Voice Name3	32..126 (ASCII)	i	
		03	1	20-7E	Voice Name4	32..126 (ASCII)	t	
		04	1	20-7E	Voice Name5	32..126 (ASCII)	j	
		05	1	20-7E	Voice Name6	32..126 (ASCII)	a	
		06	1	20-7E	Voice Name7	32..126 (ASCII)	l	
		07	1	20-7E	Voice Name8	32..126 (ASCII)	i	
		08	1	20-7E	Voice Name9	32..126 (ASCII)	z	
		09	1	20-7E	Voice Name10	32..126 (ASCII)	e	
		0A	1	20-7E	Voice Name11	32..126 (ASCII)	d	
		0B	1	20-7E	Voice Name12	32..126 (ASCII)		
		0C	1	20-7E	Voice Name13	32..126 (ASCII)	D	
		0D	1	20-7E	Voice Name14	32..126 (ASCII)	r	
		0E	1	20-7E	Voice Name15	32..126 (ASCII)	u	
		0F	1	20-7E	Voice Name16	32..126 (ASCII)	m	
		10	1	20-7E	Voice Name17	32..126 (ASCII)		
		11	1	20-7E	Voice Name18	32..126 (ASCII)		
		12	1	20-7E	Voice Name19	32..126 (ASCII)		
		13	1	20-7E	Voice Name20	32..126 (ASCII)		
		14	1		reserved			
		15	1		reserved			
		16	1		reserved			
		17	1		reserved			
		18	1	00-11	Voice Category (Main)	0..17	11 (NoAsg)	
		19	1	00-05	Voice Category (Sub)	0..5	00 (-)	
		1A	1		reserved			
		1B	1		reserved			
		1C	1		reserved			
		1D	1		reserved			
46	00	1E	1	00-33	Knob Function Select	bit0-3 KnobUp: 0=Tone1, 1=Tone2, 2=Tone3, 3=Volume/ Pan bit4-7 KnobLo: 0=EQ, 1=Fx, 2=Arp, 3=Volume/Pan	00	
		1F	1	01-7F	Pan	L63..C..R63	40	
		20	1		reserved			
		21	1	00-7F	AEG Attack Time	-64..+63	40	
		22	1	00-7F	AEG Decay Time	-64..+63	40	
		23	1		reserved			
		24	1		reserved			
		25	1		reserved			
		26	1		reserved			
		27	1		reserved			
		28	1		reserved			
		29	1		reserved			
		2A	1	00-7F	Cutoff Frequency	-64..+63	40	
		2B	1	00-7F	Resonance	-64..+63	40	
		2C	2	00-01 2E-36	EQ Low Frequency	50.1 - 2.00k	00 36	
		2E	1	20-60	EQ Low Gain	-32 - +32 (-12.00db - +12.00db)	40	
		2F	1		reserved			
		30	2	00-01 53-71	EQ Mid Frequency	139.7 - 10.1k	01 0D	
		32	1	20-60	EQ Mid Gain	-32 - +32 (-12.00db - +12.00db)	40	
		33	1	00-1F	EQ Mid Q	0 - 31 (0.7 - 10.3)	00	
		34	2	01-01 03-7F	EQ High Frequency	503.8 - 14.0k	01 67	
		36	1	20-60	EQ High Gain	-32 - +32 (-12.00db - +12.00db)	40	
		37	1		reserved			
		38	1	00-7F	Assignable Knob 1 Value	-64..+63	40	
		39	1	00-7F	Assignable Knob 2 Value	-64..+63	40	
		3A	1	00-01	Assignable Function 1 Mode	momentary, latch	01	
		3B	1	00-01	Assignable Function 2 Mode	momentary, latch	01	
		3C	1		reserved			
		3D	1		reserved			
		3E	1		reserved			
46	00	3F	1	00-7F	Volume	0 - 127	7F	
		40	1		reserved			
		41	1	10-58	Pitch Bend Range Upper	-48 - +24 [semitones]	42	
		42	1	10-58	Pitch Bend Range Lower	-48 - +24 [semitones]	3E	
		43	1	00-7F	Reverb Send	0 - 127	00	
		44	1	00-7F	Chorus Send	0 - 127	00	
46	00	45	1	00-03	Insertion Connect Type	parallel, ins A>B, ins B>A, vocoder	00	
		46	1	00-7F	Ins-EF Reverb Send Level	0 - 127	00	
		47	1	00-7F	Ins-EF Chorus Send Level	0 - 127	00	

TOTAL SIZE = 72 48 (HEX)

Address			Size	Data Range (HEX)	Parameter Name	Description	Default (HEX)	Notes
High	Mid	Low						
46	30	00	1	00-05	ARP SF Select	SF1 - SF6	00	
		01	1		reserved			
		02	2	00-02 05-2C	ARP Tempo	5..300	00 5A	
		04	1		reserved			
		05	1		reserved			
		06	2		reserved			
		08	2		reserved			
		0A	2		reserved			
		0C	2		reserved			
		0E	1	00-01	ARP Switch	off, on		
		0F	1		reserved			
		10	1		reserved			
		11	1		reserved			
		12	1	00-01	ARP Fixed SD/BD	off, on	00	
		13	1		reserved			
		14	1	00-01	ARP Loop	off, on	01	
		15	1	00-02	ARP Hold	sync-off, off, on	01	
		16	1	00-06	ARP Unit Multiply	50%, 66%, 75%, 100%, 133%, 150%, 200%	03	
		17	1	00-7F	ARP Note Limit Low	C-2..G8	00	
		18	1	00-7F	ARP Note Limit High	C-2..G8	7F	
		19	1	01-7F	ARP Velocity Limit Low	1 - 127	01	
		1A	1	01-7F	ARP Velocity Limit High	1 - 127	7F	
		1B	1	00-04	ARP Key Mode	sort, thru, direct, sort+direct, thru+direct	00	
		1C	1	00-01	ARP Velocity Mode	original, thru	00	
		1D	1	00-01	ARP Change Timing	realtime, measure	01	
		1E	1	01-07	ARP Quantize Value	32th, 16th_Triplet, 16th, 8th_Triplet, 8th, 4th_Triplet, 4th	03	
		1F	1	00-64	ARP Quantize Strength	0...100%	00	
		20	2	00-01 00-48	ARP Velocity Rate	0...200%	00 64	
		22	2	00-01 00-48	ARP Gate Time Rate	0...200%	00 64	
		24	1		reserved			
		25	1		reserved			
		26	1		reserved			
		27	1		reserved			
		28	2	00-01 08-78	ARP Swing	-120 ... 0 ... +120	01 00	
		2A	1	00-7F	ARP Accent Velocity Threshold	off, 1 ... 127	40	
		2B	1	00-01	ARP Accent Start Quantize	off, on	01	
		2C	1	3D-43	ARP Octave Range	-3 ... 0 ... +3	40	
		2D	1	36-4A	ARP Output Octave Shift	-10 ... 0 ... +10	40	
		2E	1	00-01	ARP Trigger Mode	gate, toggle	00	
		2F	1	00-01	ARP Random SFX	off, on	01	
		30	1	00-01	ARP Random SFX Keyon Control	off, on	01	
		31	1	00-7F	ARP Random SFX Velocity Offset	-64 ... 0 ... +63	40	
		32	2	00-01 1C-64	ARP Assign Velocity Rate Offset SF1	-100 ... 0 ... +100	01 00	
		34	2	00-01 1C-64	ARP Assign Gate Time Rate Offset SF1	-100 ... 0 ... +100	01 00	
		36	2	00-01 1C-64	ARP Assign Velocity Rate Offset SF2	-100 ... 0 ... +100	01 00	
		38	2	00-01 1C-64	ARP Assign Gate Time Rate Offset SF2	-100 ... 0 ... +100	01 00	
		3A	2	00-01 1C-64	ARP Assign Velocity Rate Offset SF3	-100 ... 0 ... +100	01 00	
		3C	2	00-01 1C-64	ARP Assign Gate Time Rate Offset SF3	-100 ... 0 ... +100	01 00	
		3E	2	00-01 1C-64	ARP Assign Velocity Rate Offset SF4	-100 ... 0 ... +100	01 00	
		40	2	00-01 1C-64	ARP Assign Gate Time Rate Offset SF4	-100 ... 0 ... +100	01 00	
		42	2	00-01 1C-64	ARP Assign Velocity Rate Offset SF5	-100 ... 0 ... +100	01 00	
		44	2	00-01 1C-64	ARP Assign Gate Time Rate Offset SF5	-100 ... 0 ... +100	01 00	
		46	2	00-01 1C-64	ARP Assign Velocity Rate Offset SF6	-100 ... 0 ... +100	01 00	
		48	2	00-01 1C-64	ARP Assign Gate Time Rate Offset SF6	-100 ... 0 ... +100	01 00	
		4A	2	00-3E 00-2D, 40-41 00-7F	ARP SF1 Assign Type	off, Preset 0001 ... 7981, User 001 ... 256	05 4A	MA_Pf Arp1
		4C	2	00-3E 00-2D, 40-41 00-7F	ARP SF2 Assign Type	off, Preset 0001 ... 7981, User 001 ... 256	00 00	off

Address			Size	Data Range (HEX)	Parameter Name	Description	Default (HEX)	Notes
High	Mid	Low						
		4E	2	00 - 3E 00 - 2D, 40 - 41 00 - 7F	ARP SF3 Assign Type	off, Preset 0001 ... 7981, User 001 ... 256	00 00	off
		50	2	00 - 3E 00 - 2D, 40 - 41 00 - 7F	ARP SF4 Assign Type	off, Preset 0001 ... 7981, User 001 ... 256	00 00	off
		52	2	00 - 3E 00 - 2D, 40 - 41 00 - 7F	ARP SF5 Assign Type	off, Preset 0001 ... 7981, User 001 ... 256	00 00	off
		54	2	00 - 3E 00 - 2D, 40 - 41 00 - 7F	ARP SF6 Assign Type	off, Preset 0001 ... 7981, User 001 ... 256	00 00	off

TOTAL SIZE = 86 56 (HEX)

Address			Size	Data Range (HEX)	Parameter Name	Description	Default (HEX)	Notes
High	Mid	Low						
		1C	2	00 - 7F 00 - 7F	Chorus Parameter 13	:		Init value for G Chorus / Basic
		1E	2	00 - 7F 00 - 7F	Chorus Parameter 14	:		Init value for G Chorus / Basic
		20	2	00 - 7F 00 - 7F	Chorus Parameter 15	:		Init value for G Chorus / Basic
		22	2	00 - 7F 00 - 7F	Chorus Parameter 16	:		Init value for G Chorus / Basic
		24	1	00 - 7F	Chorus Return	-->dB...0dB...+6dB (0...96...127)	60	
		25	1	01 - 7F	Chorus Pan	L63...C...R63	40	
		26	1	00 - 7F	Send Chorus To Reverb	-->dB...0dB (0...127)	00	
		27	1		reserved			

TOTAL SIZE = 40 28 (HEX)

Address			Size	Data Range (HEX)	Parameter Name	Description	Default (HEX)	Notes
High	Mid	Low						
46	01	00	2	00 - 7F 00 - 7F	Reverb Type	Refer to the "Effect Parameter List."	01 00	Rev-X Hall
		02	1	00 - 7F	Preset Number		00	Basic
		03	1		reserved			
		04	2	00 - 7F 00 - 7F	Reverb Parameter 1	Refer to the "Effect Parameter List."	Init value for Rev-X Hall / Basic	
		06	2	00 - 7F 00 - 7F	Reverb Parameter 2	:	Init value for Rev-X Hall / Basic	
		08	2	00 - 7F 00 - 7F	Reverb Parameter 3	:	Init value for Rev-X Hall / Basic	
		0A	2	00 - 7F 00 - 7F	Reverb Parameter 4	:	Init value for Rev-X Hall / Basic	
		0C	2	00 - 7F 00 - 7F	Reverb Parameter 5	:	Init value for Rev-X Hall / Basic	
		0E	2	00 - 7F 00 - 7F	Reverb Parameter 6	:	Init value for Rev-X Hall / Basic	
		10	2	00 - 7F 00 - 7F	Reverb Parameter 7	:	Init value for Rev-X Hall / Basic	
		12	2	00 - 7F 00 - 7F	Reverb Parameter 8	:	Init value for Rev-X Hall / Basic	
		14	2	00 - 7F 00 - 7F	Reverb Parameter 9	:	Init value for Rev-X Hall / Basic	
		16	2	00 - 7F 00 - 7F	Reverb Parameter 10	:	Init value for Rev-X Hall / Basic	
		18	2	00 - 7F 00 - 7F	Reverb Parameter 11	:	Init value for Rev-X Hall / Basic	
		1A	2	00 - 7F 00 - 7F	Reverb Parameter 12	:	Init value for Rev-X Hall / Basic	
		1C	2	00 - 7F 00 - 7F	Reverb Parameter 13	:	Init value for Rev-X Hall / Basic	
		1E	2	00 - 7F 00 - 7F	Reverb Parameter 14	:	Init value for Rev-X Hall / Basic	
		20	2	00 - 7F 00 - 7F	Reverb Parameter 15	:	Init value for Rev-X Hall / Basic	
		22	2	00 - 7F 00 - 7F	Reverb Parameter 16	:	Init value for Rev-X Hall / Basic	
		24	1	00 - 7F	Reverb Return	-->dB...0dB...+6dB (0...96...127)	40	
		25	1	01 - 7F	Reverb Pan	L63...C...R63	40	

TOTAL SIZE = 38 26 (HEX)

Address			Size	Data Range (HEX)	Parameter Name	Description	Default (HEX)	Notes
High	Mid	Low						
46	03	00	2	00 - 7F 00 - 7F	Insertion A Type	Refer to the "Effect Parameter List."	00 00	
		02	1	00 - 7F	Preset Number		00	Basic
		03	1		reserved			
		04	2	00 - 7F 00 - 7F	Insertion A Parameter 1	Refer to the "Effect Parameter List."	00 00	
		06	2	00 - 7F 00 - 7F	Insertion A Parameter 2	:	00 00	
		08	2	00 - 7F 00 - 7F	Insertion A Parameter 3	:	00 00	
		0A	2	00 - 7F 00 - 7F	Insertion A Parameter 4	:	00 00	
		0C	2	00 - 7F 00 - 7F	Insertion A Parameter 5	:	00 00	
		0E	2	00 - 7F 00 - 7F	Insertion A Parameter 6	:	00 00	
		10	2	00 - 7F 00 - 7F	Insertion A Parameter 7	:	00 00	
		12	2	00 - 7F 00 - 7F	Insertion A Parameter 8	:	00 00	
		14	2	00 - 7F 00 - 7F	Insertion A Parameter 9	:	00 00	
		16	2	00 - 7F 00 - 7F	Insertion A Parameter 10	:	00 00	
		18	2	00 - 7F 00 - 7F	Insertion A Parameter 11	:	00 00	
		1A	2	00 - 7F 00 - 7F	Insertion A Parameter 12	:	00 00	
		1C	2	00 - 7F 00 - 7F	Insertion A Parameter 13	:	00 00	
		1E	2	00 - 7F 00 - 7F	Insertion A Parameter 14	:	00 00	
		20	2	00 - 7F 00 - 7F	Insertion A Parameter 15	:	00 00	
		22	2	00 - 7F 00 - 7F	Insertion A Parameter 16	:	00 00	

TOTAL SIZE = 36 24 (HEX)

Address			Size	Data Range (HEX)	Parameter Name	Description	Default (HEX)	Notes
High	Mid	Low						
46	02	00	2	00 - 7F 00 - 7F	Chorus Type	Refer to the "Effect Parameter List."	03 00	G Chorus
		02	1	00 - 7F	Preset Number		00	Basic
		03	1		reserved			
		04	2	00 - 7F 00 - 7F	Chorus Parameter 1	Refer to the "Effect Parameter List."	Init value for G Chorus / Basic	
		06	2	00 - 7F 00 - 7F	Chorus Parameter 2	:	Init value for G Chorus / Basic	
		08	2	00 - 7F 00 - 7F	Chorus Parameter 3	:	Init value for G Chorus / Basic	
		0A	2	00 - 7F 00 - 7F	Chorus Parameter 4	:	Init value for G Chorus / Basic	
		0C	2	00 - 7F 00 - 7F	Chorus Parameter 5	:	Init value for G Chorus / Basic	
		0E	2	00 - 7F 00 - 7F	Chorus Parameter 6	:	Init value for G Chorus / Basic	
		10	2	00 - 7F 00 - 7F	Chorus Parameter 7	:	Init value for G Chorus / Basic	
		12	2	00 - 7F 00 - 7F	Chorus Parameter 8	:	Init value for G Chorus / Basic	
		14	2	00 - 7F 00 - 7F	Chorus Parameter 9	:	Init value for G Chorus / Basic	
		16	2	00 - 7F 00 - 7F	Chorus Parameter 10	:	Init value for G Chorus / Basic	
		18	2	00 - 7F 00 - 7F	Chorus Parameter 11	:	Init value for G Chorus / Basic	
		1A	2	00 - 7F 00 - 7F	Chorus Parameter 12	:	Init value for G Chorus / Basic	

Address			Size	Data Range (HEX)	Parameter Name	Description	Default (HEX)	Notes
High	Mid	Low						
46	04	00	2	00 - 7F 00 - 7F	Insertion B Type	Refer to the "Effect Parameter List."	00 00	
		02	1	00 - 7F	Preset Number		00	Basic
		03	1		reserved			
		04	2	00 - 7F 00 - 7F	Insertion B Parameter 1	Refer to the "Effect Parameter List."	00 00	
		06	2	00 - 7F 00 - 7F	Insertion B Parameter 2	:	00 00	
		08	2	00 - 7F 00 - 7F	Insertion B Parameter 3	:	00 00	
		0A	2	00 - 7F 00 - 7F	Insertion B Parameter 4	:	00 00	
		0C	2	00 - 7F 00 - 7F	Insertion B Parameter 5	:	00 00	
		0E	2	00 - 7F 00 - 7F	Insertion B Parameter 6	:	00 00	
		10	2	00 - 7F 00 - 7F	Insertion B Parameter 7	:	00 00	
		12	2	00 - 7F 00 - 7F	Insertion B Parameter 8	:	00 00	
		14	2	00 - 7F 00 - 7F	Insertion B Parameter 9	:	00 00	
		16	2	00 - 7F 00 - 7F	Insertion B Parameter 10	:	00 00	
		18	2	00 - 7F 00 - 7F	Insertion B Parameter 11	:	00 00	
		1A	2	00 - 7F 00 - 7F	Insertion B Parameter 12	:	00 00	
		1C	2	00 - 7F 00 - 7F	Insertion B Parameter 13	:	00 00	
		1E	2	00 - 7F 00 - 7F	Insertion B Parameter 14	:	00 00	

Address			Size	Data Range (HEX)	Parameter Name	Description	Default (HEX)	Notes
High	Mid	Low						
		20	2	00 - 7F 00 - 7F	Insertion B Parameter 15	:	00 00	
		22	2	00 - 7F 00 - 7F	Insertion B Parameter 16	:	00 00	

TOTAL SIZE = 36 24 (HEX)

Address			Size	Data Range (HEX)	Parameter Name	Description	Default (HEX)	Notes
High	Mid	Low						
46	05	00	2	00 - 7F 00 - 7F	Insertion L Type	Refer to the "Effect Parameter List."	00 00	
		02	1	00 - 7F	Preset Number		00	Basic
		03	1		reserved			
		04	2	00 - 7F 00 - 7F	Insertion L Parameter 1	Refer to the "Effect Parameter List."	00 00	
		06	2	00 - 7F 00 - 7F	Insertion L Parameter 2	:	00 00	
		08	2	00 - 7F 00 - 7F	Insertion L Parameter 3	:	00 00	
		0A	2	00 - 7F 00 - 7F	Insertion L Parameter 4	:	00 00	
		0C	2	00 - 7F 00 - 7F	Insertion L Parameter 5	:	00 00	
		0E	2	00 - 7F 00 - 7F	Insertion L Parameter 6	:	00 00	
		10	2	00 - 7F 00 - 7F	Insertion L Parameter 7	:	00 00	
		12	2	00 - 7F 00 - 7F	Insertion L Parameter 8	:	00 00	
		14	2	00 - 7F 00 - 7F	Insertion L Parameter 9	:	00 00	
		16	2	00 - 7F 00 - 7F	Insertion L Parameter 10	:	00 00	
		18	2	00 - 7F 00 - 7F	Insertion L Parameter 11	:	00 00	
		1A	2	00 - 7F 00 - 7F	Insertion L Parameter 12	:	00 00	
		1C	2	00 - 7F 00 - 7F	Insertion L Parameter 13	:	00 00	
		1E	2	00 - 7F 00 - 7F	Insertion L Parameter 14	:	00 00	
		20	2	00 - 7F 00 - 7F	Insertion L Parameter 15	:	00 00	
		22	2	00 - 7F 00 - 7F	Insertion L Parameter 16	:	00 00	
		24	2	00 - 7F 00 - 7F	Insertion L Parameter 17	:	00 00	
		26	2	00 - 7F 00 - 7F	Insertion L Parameter 18	:	00 00	
		28	2	00 - 7F 00 - 7F	Insertion L Parameter 19	:	00 00	
		2A	2	00 - 7F 00 - 7F	Insertion L Parameter 20	:	00 00	
		2C	2	00 - 7F 00 - 7F	Insertion L Parameter 21	:	00 00	
		2E	2	00 - 7F 00 - 7F	Insertion L Parameter 22	:	00 00	
		30	2	00 - 7F 00 - 7F	Insertion L Parameter 23	:	00 00	
		32	2	00 - 7F 00 - 7F	Insertion L Parameter 24	:	00 00	
		34	2	00 - 7F 00 - 7F	Insertion L Parameter 25	:	00 00	
		36	2	00 - 7F 00 - 7F	Insertion L Parameter 26	:	00 00	
		38	2	00 - 7F 00 - 7F	Insertion L Parameter 27	:	00 00	
		3A	2	00 - 7F 00 - 7F	Insertion L Parameter 28	:	00 00	
		3C	2	00 - 7F 00 - 7F	Insertion L Parameter 29	:	00 00	
		3E	2	00 - 7F 00 - 7F	Insertion L Parameter 30	:	00 00	
		40	2	00 - 7F 00 - 7F	Insertion L Parameter 31	:	00 00	
		42	2	00 - 7F 00 - 7F	Insertion L Parameter 32	:	00 00	

TOTAL SIZE = 68 44 (HEX)

Address			Size	Data Range (HEX)	Parameter Name	Description	Default (HEX)	Notes
High	Mid	Low						
46	08	00	1	00 - 7F	Controller Set1 Depth	-64 - +63	40	
		01	1	00 - 0E	Controller Set1 Source	0: PB, 1: MW, 3: AT, 4: FC, 5: FS, 6: RB, 7: BC, 8: AKN1, 9: AKN2, 12: FC2, 13: ASW1, 14: ASW2	01	
		02	2	00 - 00 00 - 20, 00 - 00 41 - 43	Controller Set1 Destination	0 - 32, 65 - 67	00 00	
		04	1	00 - 7F	Controller Set2 Depth	-64 - +63	40	
		05	1	00 - 0E	Controller Set2 Source	0: PB, 1: MW, 3: AT, 4: FC, 5: FS, 6: RB, 7: BC, 8: AKN1, 9: AKN2, 12: FC2, 13: ASW1, 14: ASW2	01	
		06	2	00 - 00 00 - 20, 00 - 00 41 - 43	Controller Set2 Destination	0 - 32, 65 - 67	00 00	
		08	1	00 - 7F	Controller Set3 Depth	-64 - +63	40	
		09	1	00 - 0E	Controller Set3 Source	0: PB, 1: MW, 3: AT, 4: FC, 5: FS, 6: RB, 7: BC, 8: AKN1, 9: AKN2, 12: FC2, 13: ASW1, 14: ASW2	01	
		0A	2	00 - 00 00 - 20, 00 - 00 41 - 43	Controller Set3 Destination	0 - 32, 65 - 67	00 00	
		0C	1	00 - 7F	Controller Set4 Depth	-64 - +63	40	
		0D	1	00 - 0E	Controller Set4 Source	0: PB, 1: MW, 3: AT, 4: FC, 5: FS, 6: RB, 7: BC, 8: AKN1, 9: AKN2, 12: FC2, 13: ASW1, 14: ASW2	08	
		0E	2	00 - 00 00 - 20, 00 - 00 41 - 43	Controller Set4 Destination	0 - 32, 65 - 67	00 00	
		10	1	00 - 7F	Controller Set5 Depth	-64 - +63	40	
		11	1	00 - 0E	Controller Set5 Source	0: PB, 1: MW, 3: AT, 4: FC, 5: FS, 6: RB, 7: BC, 8: AKN1, 9: AKN2, 12: FC2, 13: ASW1, 14: ASW2	09	
		12	2	00 - 00 00 - 20, 00 - 00 41 - 43	Controller Set5 Destination	0 - 32, 65 - 67	00 00	
		14	1	00 - 7F	Controller Set6 Depth	-64 - +63	40	
		15	1	00 - 0E	Controller Set6 Source	0: PB, 1: MW, 3: AT, 4: FC, 5: FS, 6: RB, 7: BC, 8: AKN1, 9: AKN2, 12: FC2, 13: ASW1, 14: ASW2	03	
		16	2	00 - 00 00 - 20, 00 - 00 41 - 43	Controller Set6 Destination	0 - 32, 65 - 67	00 00	

TOTAL SIZE = 24 18 (HEX)

MIDI PARAMETER CHANGE TABLE (DRUM VOICE KEY)

Address			Size	Data Range (HEX)	Parameter Name	Description	Default (HEX)	Notes
High	Mid	Low						
47	ee	00	1	00 – 01	Element Switch	off, on	01	
		01	1	00 – 01	Wave Select	0=preset, 1=user	00	
		02	2	00 – 1F 01 – 09	Wave Number	1 – 3977	15 6E	
		04	1	00 – 01	Receive Note Off	off, on	00	
		05	1	00 – 01	Key Assign Mode	single, multi	01	
		06	1	00 – 7F	Alternate Group	0: off, 1 – 127	00	
		07	1	01 – 7F	Pan	L63 – C – R63	40	
		08	1	00 – 7F	Random Pan Depth	0 – 127	00	
		09	1	00 – 7F	Alternate Pan Depth	L64 – 0 – R63	40	
		0A	1	00 – 7F	Reverb Send Level	0 – 127	5A	
		0B	1	00 – 7F	Chorus Send Level	0 – 127	00	
		0C	1	00 – 02	Insertion Effect	thru, insA, insB	00	
		0D	1		reserved			
47	ee	0E	1	00 – 7F	Element Level	0 – 127	7F	
		0F	1	00 – 7F	Level Velocity Sensitivity	-64 – +63	40	
		10	1		reserved			
		11	1	00 – 7F	AEG Attack Time	0 – 127	00	
		12	1	00 – 7F	AEG Decay1 Time	0 – 127	60	
		13	1	00 – 7F	AEG Decay2 Time	0 – 126, hold	50	
		14	1		reserved			
		15	1		reserved			
		16	1		reserved			
		17	1	00 – 7F	AEG Decay1 Level	0 – 127	7F	
		18	1		reserved			
		19	1		reserved			
47	ee	1A	1	10 – 70	Coarse Tune	-48 – +48	40	
		1B	1	00 – 7F	Fine Tune	-64 – +63	40	
		1C	1	00 – 7F	Pitch Velocity Sensitivity	-64 – +63	40	
		1D	1		reserved			
47	ee	1E	2	00 – 01 00 – 7F	LPF Cutoff Frequency	0 – 255	01 7F	
		20	1	00 – 7F	LPF Cutoff Velocity Sensitivity	-64 – +63	40	
		21	1	00 – 7F	LPF Resonance	0 – 127	00	
		22	2	00 – 01 00 – 7F	HPF Cutoff Frequency	0 – 255	00 00	
		24	1	00 – 05	EQ Type	2 Band, P.EQ, Boost6, Boost12, Boost18, thru	00	
		25	1	00 – 1F	EQ Q	0 – 31 (0.7 – 10.3)	00	
		26	2	00 – 01 2E – 7B	EQ 1 Frequency	2 Band: 46-182, P.EQ: 83-251	00 36	
		28	1	20 – 60	EQ 1 GAIN	-32 – +32	40	
		29	1		reserved			
		2A	2	01 – 01 03 – 71	EQ 2 Frequency	2 Band: 131-241	01 67	
		2C	1	20 – 60	EQ 2 GAIN	-32 – +32	40	
		2D	1		reserved			

TOTAL SIZE = 46 2E (HEX)
ee = element number (00 – 48: C0 – C6)

Function...	Transmitted	Recognized	Remarks	
Basic Channel	Default Changed	1 - 16 1 - 16	1 - 16 1 - 16	Memorized
Mode	Default Messages Altered	3 x *****	1 - 4 (m=1) *2 1 - 4 (m=1) *2 x	Memorized
Note Number : True voice		0 - 127 *****	0 - 127 0 - 127	Transpose
Velocity	Note ON Note OFF	o 9nH,v=1-127 x 9nH,v=0	o 9nH,v=1-127 x	
After Touch	Key's Ch's	x o *3	x o *1	
Pitch Bend		o	o *1	
Control Change	0,32 1,7,10,11 5 6,38 64 65 66 71-75 91,93 96-97 100-101 1-31,33-95	o o x x o x x o o o x x o	o o o o o o o o o o o o o	*1 *1 *1 *1 *1 *1 *1 *1 *1 *1 *1 *1 *1 *1 Bank Select Portamento Time Data Entry Sustain Sw Portamento Sw Sostenuto Sound Controller Effect Depth RPN Inc,Dec RPN LSB,MSB Assignable Cntrl
Prog Change : True #		o 0 - 127 *****	o 0 - 127 *1 0 - 127 *1	
System Exclusive		o	o	
Common	: Song Pos. : Song Sel. : Tune	x x x	x x x	
System Real Time	: Clock : Commands	x x	o x	
Aux Mes-sages	: All Sound Off : Reset All Cntrls : Local ON/OFF : All Notes OFF : Active Sense : Reset	x x x x o x	o (120,126,127) o (121) x o (123-125) o x	
Notes: *1 Recognized if receive switch is on. *2 "m" is always treated as "1" regardless of its actual value. *3 Even though the keyboard itself doesn't support after touch control, after touch data can be transmitted via the Arpeggio function when a User Arpeggio with after touch data is selected.				

Mode 1 : OMNI ON , POLY Mode 2 : OMNI ON ,MONO o : Yes
 Mode 3 : OMNI OFF, POLY Mode 4 : OMNI OFF,MONO x : No

Function...	Transmitted	Recognized	Remarks
Basic Channel Default Changed	1 - 16 x	1 - 16 x	Memorized
Mode Default Messages Altered	x x *****	x x x	
Note Number : True voice	0 - 127 *****	0 - 127	
Velocity Note ON Note OFF	o 9nH,v=1-127 x 9nH,v=0	o 9nH,v=1-127 x	
After Touch Key's Ch's	o o	o o	
Pitch Bend	o	o	
Control Change 0-121	o	o	
Prog Change : True #	o 0 - 127 *****	o 0 - 127	
System Exclusive	o	o	
Common : Song Pos. : Song Sel. : Tune	o *1 o *1 x	o *1 o *1 x	
System : Clock Real Time: Commands	o *2 o *1	o *3 o *1	
Aux : All Sound Off : Reset All Cntrls : Local ON/OFF Mes- : All Notes OFF sages: Active Sense : Reset	o o o x x x	o o o x x x	
Notes:	*1 if Sequencer Control in/out is enabled. *2 if MIDI Clock Out is on. *3 if MIDI Sync is external or auto. send MMC(stop,deffered play,locate) if sync mode is MTC. receive MTC quarter frame message if sync mode is MTC.		

Mode 1 : OMNI ON , POLY
 Mode 3 : OMNI OFF, POLY

Mode 2 : OMNI ON ,MONO
 Mode 4 : OMNI OFF,MONO

o : Yes
 x : No



Yamaha Web Site (English)
<http://www.yamahasyth.com/>
Yamaha Downloads
<http://download.yamaha.com/>