

# W56964 BRIEF



## 64-NOTE POLYPHONIC RINGTONE CHIP

### ***Table of Contents-***

1.	DESCRIPTION.....	2
2.	FEATURES .....	2
3.	PACKAGE CONFIGURATION .....	3
4.	TYPICAL APPLICATION .....	4
5.	REVISION HISTORY .....	4



## 1. DESCRIPTION

The W56964 is designed for the ringtone application of cell phones with 64-note MIDI plus ADPCM/PCM synthesis. This single chip consists of a CPU interface, FIFO buffering, a wavetable sound set, a MIDI sequencer, a wavetable synthesizer, DAC, and a power amplifier to drive an 8-ohm speaker directly.

With an on-chip, high-quality, GM-compliant sound set, the W56964 supports up to 128 instruments and 47 drums for playback of any MIDI songs with up to 64 notes simultaneously. MIDI songs in various formats can be downloaded and played back via the CPU interface between the baseband CPU and W56964.

The ADPCM/PCM synthesizer is designed to allow for customized SFX (sound effects), in addition to ordinary MIDI songs. The sound effects can be played along with the MIDI tunes for more fantastic sound experiences.

Synchronization among MIDI, SFX, LED, and MTR is done using embedded events in the MIDI file, which the W56964 would decode and process accordingly. The LED and MTR output pins with 256-level control output can be used for brightness and speed control, respectively.

In addition, API (Application Program Interface) source code is provided for the CPU to control the W56964 easily via the memory bus interface.

## 2. FEATURES

- General MIDI compliant sound set: 128 instruments + 47 drums
- 64-note, 100% wavetable MIDI synthesizer with ADPCM/PCM synthesis
- High quality sound
- Simultaneous playback of
  - Two MIDI song files,
  - Two ADPCM files, or
  - ADPCM + MIDI
- Karaoke feature support
- MIP support for SP-MIDI format
- Middleware API source code provided for function control and CPU interface
- Multiple Format Parser that supports
  - MIDI: SMF, SP-MIDI, i-Melody, RTTTL, etc.
  - Audio: stereo WAV @ 48 KHz
- Stereophonic DAC with 12-bit resolution per channel
- On-chip power amplifier to drive 8Ω speaker directly
- Equalizer embedded to meet speaker response
- Stereophonic headphone outputs available
- Line-In to receive external analog signals
- LED output with 256 levels of brightness

# W56964 BRIEF



- MTR output with 256 levels of speed
- Harmonized synchronization between MIDI, SFX, LED, and MTR
- Embedded PLL operates on 1.7 ~ 36 MHz clock input
- Power supply
  - VDD: 2.7 ~ 3.3 volt
  - SPVDD: 2.7 ~ 4.5 volt
  - IOVDD: 1.65 ~ VDD
- Operating current: 20 mA (25°C at no load)
- Standby current: 1 uA @ 25°C
- Operating temperature: -20°C ~ 85°C
- Package
  - 32-pin plastic QFN (5.2mmx6.2mmx1mm)

### 3. PACKAGE CONFIGURATION

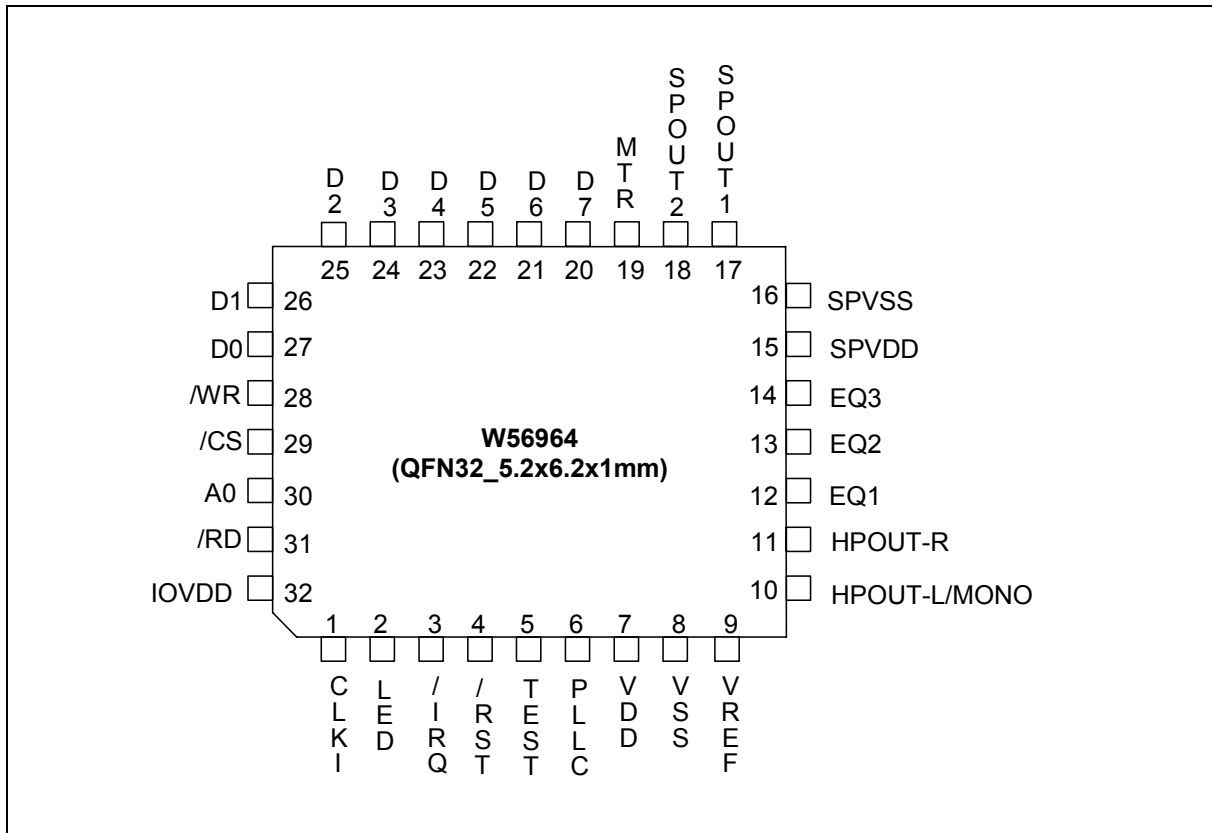

# W56964 BRIEF



## 4. TYPICAL APPLICATION

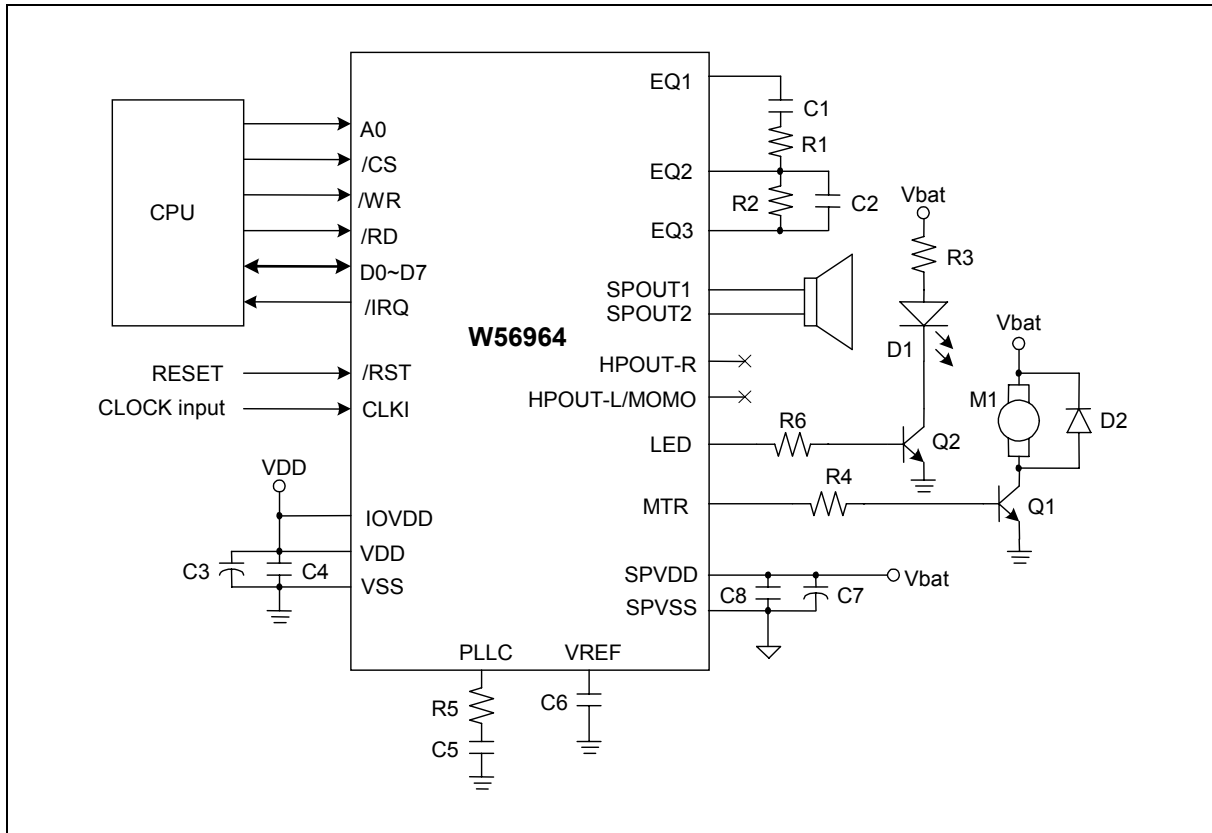

## 5. REVISION HISTORY

VERSION	DATE	PAGE	DESCRIPTION
A1	SEP. 2004	-	-
A2	MAY 31, 2005	-	Revised by Brent and add important notice



## Important Notice

Winbond products are not designed, intended, authorized or warranted for use as components in systems or equipment intended for surgical implantation, atomic energy control instruments, airplane or spaceship instruments, transportation instruments, traffic signal instruments, combustion control instruments, or for other applications intended to support or sustain life. Further more, Winbond products are not intended for applications wherein failure of Winbond products could result or lead to a situation wherein personal injury, death or severe property or environmental damage could occur.

Winbond customers using or selling these products for use in such applications do so at their own risk and agree to fully indemnify Winbond for any damages resulting from such improper use or sales.



### Headquarters

No. 4, Creation Rd. III,  
Science-Based Industrial Park,  
Hsinchu, Taiwan  
TEL: 886-3-5770066  
FAX: 886-3-5665577  
<http://www.winbond.com.tw/>

### Taipei Office

9F, No.480, Rueiguang Rd.,  
Neihu District, Taipei, 114,  
Taiwan, R.O.C.  
TEL: 886-2-8177-7168  
FAX: 886-2-8751-3579

### Winbond Electronics Corporation America

2727 North First Street, San Jose,  
CA 95134, U.S.A.  
TEL: 1-408-9436666  
FAX: 1-408-5441798

### Winbond Electronics Corporation Japan

7F Daini-ueno BLDG, 3-7-18  
Shinyokohama Kohoku-ku,  
Yokohama, 222-0033  
TEL: 81-45-4781881  
FAX: 81-45-4781800

### Winbond Electronics (Shanghai) Ltd.

27F, 2299 Yan An W. Rd. Shanghai,  
200336 China  
TEL: 86-21-62365999  
FAX: 86-21-62365998

### Winbond Electronics (H.K.) Ltd.

Unit 9-15, 22F, Millennium City,  
No. 378 Kwun Tong Rd.,  
Kowloon, Hong Kong  
TEL: 852-27513100  
FAX: 852-27552064

*Please note that all data and specifications are subject to change without notice.  
All the trade marks of products and companies mentioned in this data sheet belong to their respective owners.*