

Digital IF Sub Sampling Using the HI5702, HSP45116 and HSP43220

Author: Carl Andren and John Fakatselis

Introduction

This note is about the conversion of previously analog receiver designs into a digital form. It includes a technique for IF sub sampling that can simplify the digital circuits compared to a one to one correspondence with analog methods. An example of a Digital Receiver design based on off-the shelf Harris Components, is included.

Discussion

It is often desired to downconvert a bandpass signal to its baseband representation. Bandpass signals can be expressed as a sum of two quadrature components which are 90 degrees out of phase. In general:

$$x(t) = x_1(t) \cos\omega_c t + x_2(t) \sin\omega_c t$$

where $x_1(t)$ is the in phase component, $x_2(t)$ is the quadrature component of the signal $x(t)$ and ω_c is the center frequency of the band pass signal (carrier frequency).

In the down conversion process the receiver needs to effectively shift the carrier frequency ω_c to baseband (DC). To achieve this one must multiply the incoming bandpass signal $x(t)$ with the complex phasor $[\cos\omega_c t - j\sin\omega_c t]$ and then low pass filter the result. This operation will accomplish the desired frequency shift.

$$x(t) [\cos\omega_c t - j\sin\omega_c t] = 1/2[x_1(t) + x_1(t) \cos 2\omega_c t - jx_1(t) \sin 2\omega_c t + x_2(t) \sin 2\omega_c t - jx_2(t) + jx_2(t) \cos 2\omega_c t]$$

After low pass filtering the second harmonic components are filtered out and the result is the desired baseband signal representation of $x(t)$:

$$\text{LPF (output)} = 1/2[x_1(t) - j x_2(t)]$$

Figure 1 illustrates the functional block diagrams that represent this mathematical process.

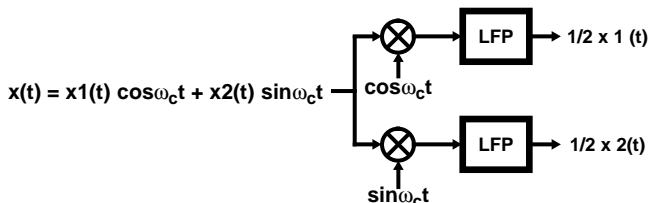

FIGURE 1. BASEBAND DOWNCONVERSION BLOCK DIAGRAM

An all digital implementation of this function implies that the an A/D converter needs to digitize the incoming waveform $x(t)$.

The carrier frequency ω_c is typically much higher than the frequency of the actual baseband signal. The Nyquist criterion specifies the minimum sampling rate of the A/D required for signal reconstruction. This minimum sampling rate is defined as twice the frequency of the baseband signal. Based on this definition alone it appears that the carrier frequency ω_c does not influence the sampling rate of the A/D converter. For example, if a baseband signal of 9600 bits/sec is transmitted using a ω_c of 45MHz at the A/D input, then the sampling rate to reconstruct the 9600 bits/sec signal needs to be a minimum of $9600 \times 2 = 19.2\text{kHz}$. The 19.2kHz rate is the signal reconstruction requirement for the sampling rate independent of the value of ω_c . Based on this discussion, a low speed A/D can potentially be used to sample the signal at very high IF frequencies and still recover the baseband information. This concept is referred as under sampling or sub sampling. Sub sampling makes an all digital implementation of down conversion at high IF frequencies (i.e. 40MHz-200MHz) feasible. This is because A/Ds would no longer present a limiting factor. A/Ds at low sampling rates are relatively inexpensive and available. From a pure, Nyquist rate, theoretical standpoint this appears as a viable approach. In practice though there are a number of additional factors that need to be evaluated for such a design. The A/D requirements are still a key factor and they impact the design outcome and overall feasibility to a great extent. The designer must carefully analyze the following requirements before deciding on an A/D for a particular under sampling application.

A/D dynamic range requirement: This is derived by examining the operational environment and desired system signal to noise ratio. The noise environment, signal interference conditions, multipath, and adjacent channel rejection requirements are some of the primary variables that influence the dynamic range specifications of the A/D in a classical receiver architecture. In addition, the existence of a system AGC and the parameters of the filters that proceed the A/D need to be taken into account for these calculations.

A/D sampling rate requirement: This is derived primarily from the baseband signal bandwidth. The minimum rate is defined by the Nyquist criterion. The overall system frequency plan and the baseband digital rates required by the system can also influence the decision on the rate selection. Implementation issues such as availability of only certain clock rates can also play a role in selecting the sampling rate. A minimum rate may be set by the A/D Track and Hold droop specification.

A/D Track and Hold aperture jitter requirement: This requirement is a function of the IF frequency. The track and hold circuit must have enough bandwidth to adequately cover the IF frequency that is being sampled. In addition, the effects on the system performance due to the sampling aperture error have to be evaluated. The aperture jitter of the track and hold directly influences this aperture error result. The degradation due to aperture jitter is a function of the sampled IF frequency. The higher the IF frequency the tighter the track and hold aperture jitter requirements become in order to maintain a desired aperture error system specification.

An example of a digital receiver application will be used to further elaborate on under sampling and to demonstrate the points made thus far.

This design is based on the Harris HI5702 A/D for the IF sampling, the Harris HSP45116 numerically controlled oscillator /modulator (NCOM) to perform the multiplication of the A/D samples with the complex phasor $[\cos\omega_c t - j\sin\omega_c t]$, followed by the Harris decimating digital filters HSP43220 that generate the low rate filtered baseband data. The down conversion and filtering operations are followed with a digital FSK/FM demodulator that processes the baseband in phase (I) and quadrature (Q) data as it is being output from the digital low pass filters (HSP43220). The digital demodulator can be a simple discriminator implementation based on delay and multiply calculations on the I and Q channels. Figure 2 illustrates this general purpose digital IF design. The block diagram includes an optional AGC circuit. The utility of this AGC circuit is explained later in this paper.

The target receiver design is a standard FSK/FM receiver with a 45MHz IF and 25kHz of channel bandwidth. It is also assumed that the FSK data has a deviation of $(\pm 6.4\text{kHz})$. This example can be modified for ETACS, AMPS, Nordic Telephone, MMP and other applications. Existing systems that use traditional analog techniques place the A/D after the analog discriminator which performs the FSK/FM demodulation. These systems experience problems with matching the pre detection filtering to the discriminator. Assuming the S curve characteristics of the analog discriminator, it is apparent that frequency matching of the analog filters becomes essential to maintain acceptable performance. The digital implementation doesn't suffer from possible filter mismatching and digital filters are not subject to phase non linearities. In addition, the digital approach can improve the performance of the adjacent signal rejection over the rejection that is provided by the analog IF filter, in front of the A/D converter.

The diagram on Figure 2 shows this basic approach which uses sub sampling to convert the 45MHz IF to a 1MHz IF. This assumes that the track and hold is integrated with the A/D as is the case with the HI5702. The frequency spectrum diagrams in Figure 2 show the basic signal processing flow in sub sampling. The input signal is first filtered using an analog IF bandpass filter and then amplified by an ACG amplifier to a level sufficient to drive the A/D converter. It is then sampled by the high speed track and hold and quantized by a 4MHz rate clock at the A/D converter. The sampling process creates a spectrum that repeats the original spectrum every multiple of the sampling frequency as shown in Figure 3. The negative part of the spectrum is shown folded back on and interleaved with the positive part.

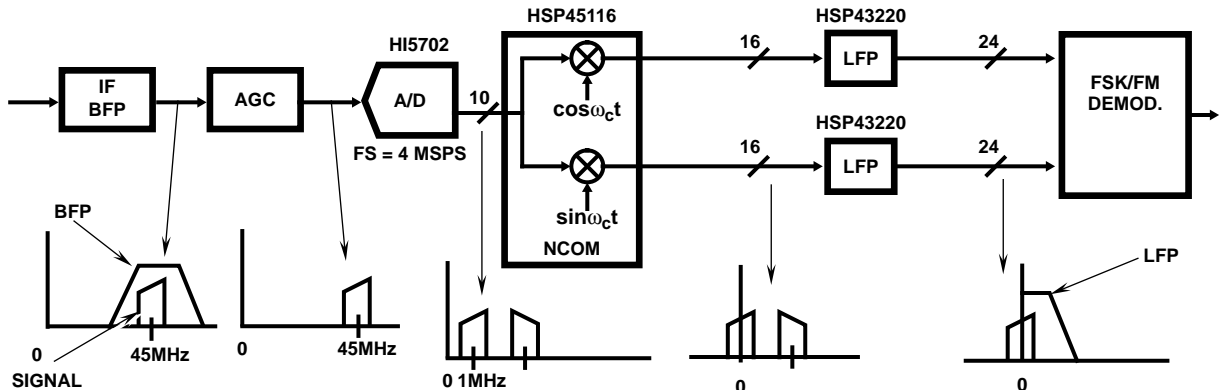

FIGURE 2. DIGITAL IF BASEBAND DOWNCONVERSION BLOCK DIAGRAM

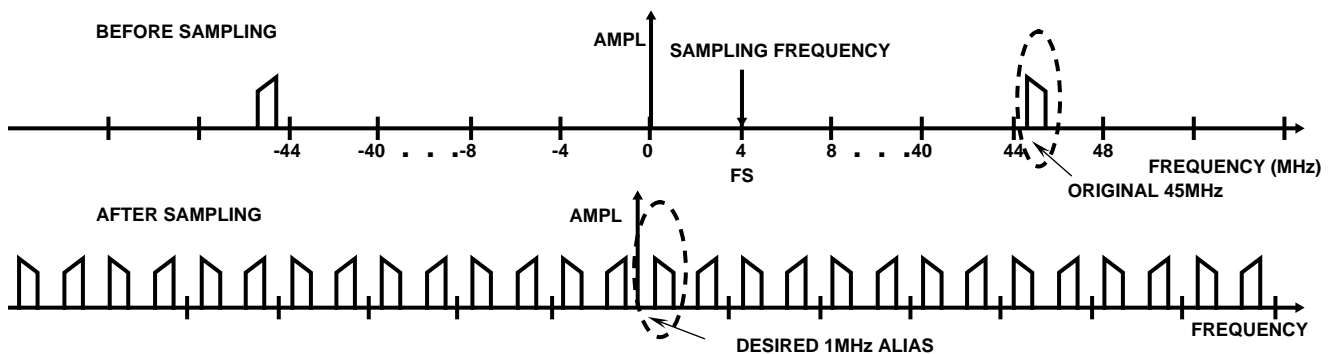

FIGURE 3. UNDERSAMPLING FREQUENCY PLAN

Application Note 9509

Two of the repeats (aliases) can be found at frequencies between the sampling frequency and DC. The sub sampling approach can be thought of as generating a signal replica at a much lower IF frequency close to DC. In this example the aliased signal is centered at 1MHz. This signal is later going to be processed by the NCOM, as shown in Figure 2, to shift it and center it at DC where it can be digitally filtered. The sampling rate as well as the bit resolution of the A/D are chosen based on the following considerations:

1. The highest usable sampling rate is set by the A/D converter and the subsequent digital processing circuits. For low power operation and ease of processing, the lower the rate, the better. Fundamentally, the lowest rate is twice the signal bandwidth according to the Nyquist criterion. For this example, that works out to 50kHz given that the signal occupies a 25kHz channel. Practically, however, the filtering in the RF and IF circuits is usually not sufficient to insure good performance this close in. The sampling frequency has to be high enough so that any noise and interference passing through the RF and IF filtering does not fold back within the sampling bandwidth. These filters only partially reject interference for a bandwidth that is wider than the channel bandwidth. Additionally, the minimum sampling rate is set by the lowest rate that the A/D converter can use without suffering too much track & hold droop. For the Harris HI5702, the lowest rate is 0.5MHz. For these reasons, the sampling rate was chosen to be 4MHz. This sampling rate aliases the 45MHz IF to create the 1MHz IF. This rate is also easily handled by the Harris Digital Signal Processing devices (HSP45116, HSP43220) which follow with complex down conversion, decimating and filtering. Higher sampling rates can also be employed if more over sampling of the baseband signal is desired.
2. The digital filters that follow in the processing chain can provide additional adjacent channel rejection to improve selectivity beyond what the analog IF filter is offering. This additional selectivity can be 30-40dB more than provided by the IF filter prior to the A/D. In this example the combination of the analog IF filter and the digital filter selectivities can provide overall adjacent channel rejections of 60dB to 70dB.

One consideration to be addressed is the placement of gain and the use of AGC. In most analog designs, the majority of the gain is in the final IF after the filtering that establishes the selectivity. Since we are using digital processing to do some of this filtering, large interfering signals might exist at the input to the A/D converter. We cannot allow clipping in the IF prior to the A/D converter because of these adjacent channel signals. For this reason, the A/D will have to be operated with adequate headroom in order to insure that the adjacent channel signals are not above full scale. Another reason to use headroom is Raleigh fading due to multipath. This phenomenon causes rapid variations in the signal level for a number of applications such as a mobile cellular terminal. The receiver of this fading signal needs to handle variations that can potentially range from +10dB to -40dB.

Excluding the requirements for multipath and interference, for +10dB of pre detection SNR alone, the required number of A/D bits is 2 (assuming ~ 6dB/bit).

The system, though, needs to achieve 40dB more adjacent channel rejection which implies that the SNR at the A/D will be at -30dB or so given the +10dB of pre detection SNR that is needed. This, along with 6dB of headroom, sets the required A/D quantization to a minimum of 6 bits or about 36dB of ENOB (equivalent number of bits). To insure good ENOB performance, an 8-bit A/D should be sufficient. Note that the driving specification for the A/D is the spurious free dynamic range that the system requires.

3. In choosing the sub sampling rate one should also be concerned with the phase noise due to the clock edge jitter of the sampling clock. This combined with the inherent aperture jitter in the A/D can limit of how low the sampling rate can be set.

An approximation to the aperture error of the A/D converter can be derived from the formula:

$$t_a = \frac{1}{2^n \text{IF}_{\text{max}}}$$

where:

n = number of bits

t_a = aperture error

F_{max} = IF frequency

For the given IF frequency and sampling rate the aperture error of the A/D converter needs to be less than 27ps for a 1 LSB degradation at 8 bits. The hold time is 250ns for the 4MHz sampling rate. All of these requirements are met or exceeded with the HI 5702 A/D converter.

4. The quantization noise is another noise source that needs attention. For this example, given the choice of the sampling frequency, the quantization noise will be spread over the 4MHz bandwidth and will therefore be attenuated when the signal is filtered to 25kHz bandwidth during the pre detection filtering. This reduction in bandwidth gives 22dB of SNR improvement. With a required SNR of 35dB in 3kHz of bandwidth after the final filtering at the FM demodulator, the quantization noise is not of concern. The digital filtering process needs to also be evaluated since this process is essential to achieve the additional filter selectivity for the overall system. By using the HSP43220 the additional filter selectivity desired for this application can be achieved. The HSP43220 is a decimating digital filter. Decimation is the filtering operation employed in digital filtering that accomplishes the rate reduction from filter input to filter output. A summary of the HSP43220 features include:
 - DC to 33 MHz clock rate
 - 16-bit 2's complement input
 - 20-bit coefficients
 - 24-bit extended precision output
 - Programmable Decimation up to a maximum of 16,384

Decimation factors, sampling rates and number of filter taps need to be traded in configuring the filter response. For the application of this example the HSP43220 can be programmed to provide the desired filter response. An example of two possible filter specifications are attached. The filter coefficients for these two cases were generated using Decimate which is a software filter design tool developed for the HSP43220. The user defines the desired filter response and the program determines if the HSP43220 can implement the given response and then it derives the necessary coefficients, and hardware configuration.

Application Note 9509

The filter parameters as well as the frequency response for these two filter examples are as follows:

- Filter 1. Passband = 7500
- Transition Band = 3000
- Passband Attenuation = 0.5dB
- Stopband Attenuation = 60dB
- Input Sample Rate = 4e+06
- FIR Input Rate = 125000
- Output Rate = 62500

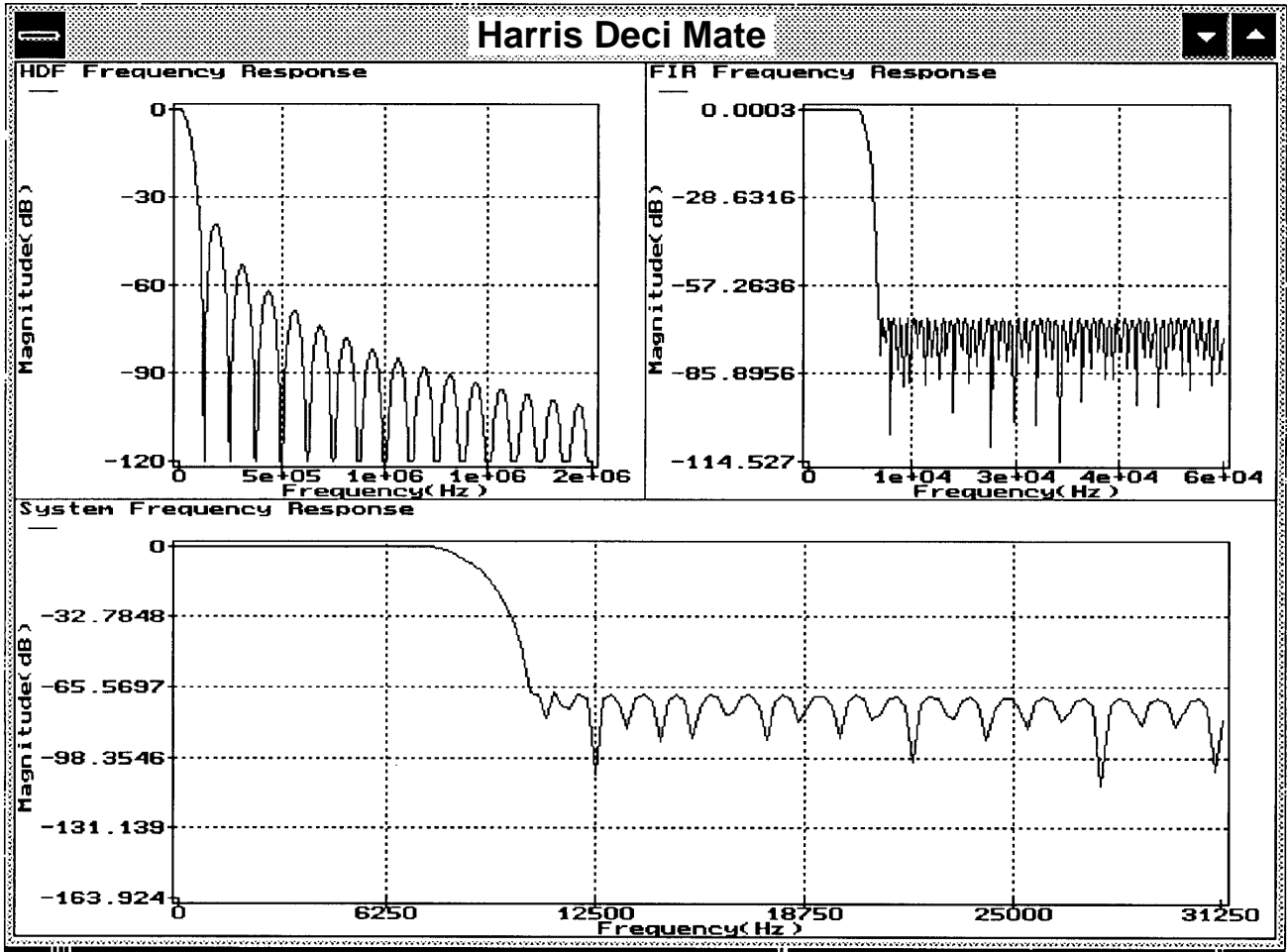

Application Note 9509

Filter 2. Passband = 10000
 Transition Band = 3000
 Passband Attenuation = 0.5dB
 Stopband Attenuation = 60dB
 Input Sample Rate = 4e+06
 FIR Input Rate = 125000
 Output Rate = 62500

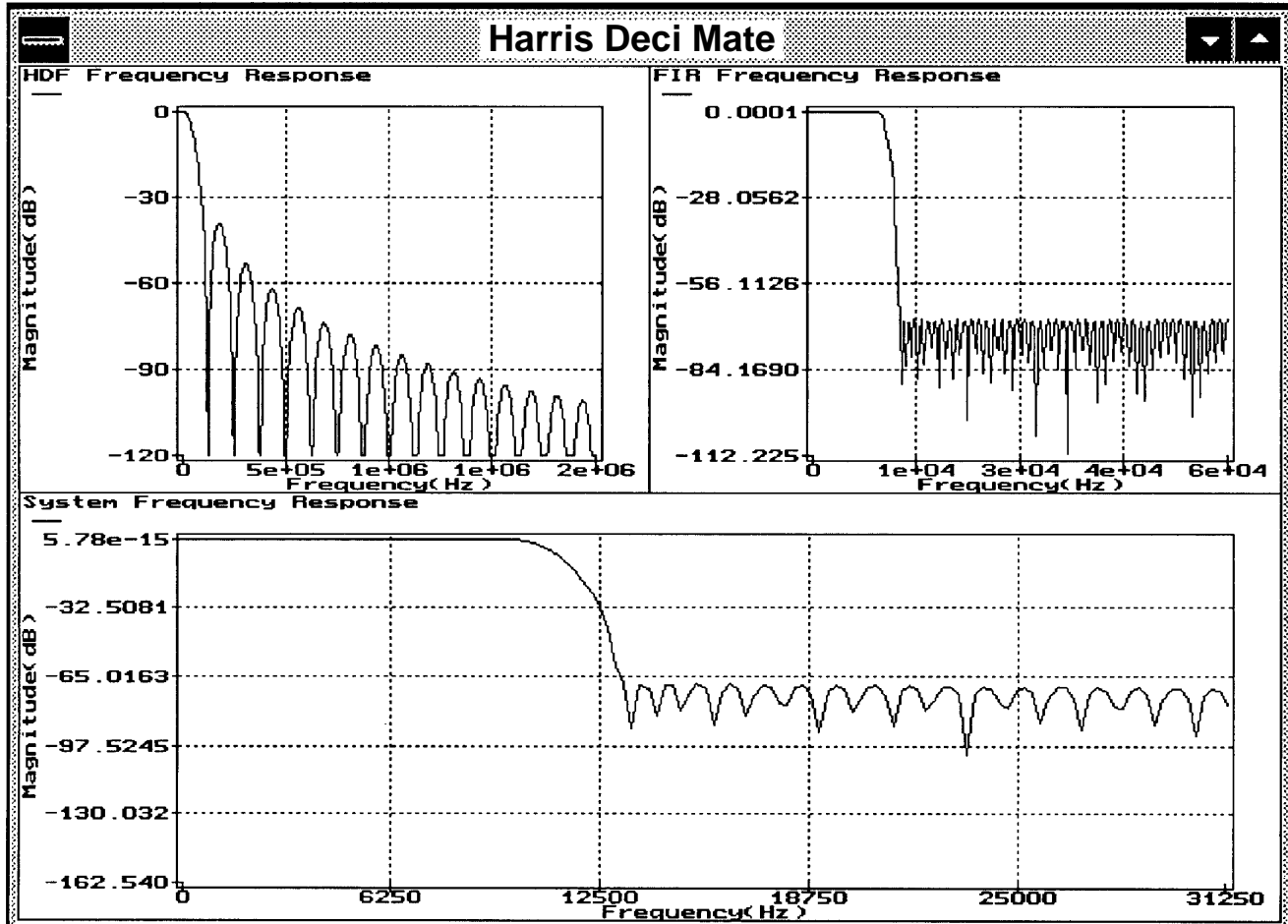

The HSP43220 architecture is composed of the cascade of two filtering stages. The High order Decimation Filter (HDF), followed by a Finite Impulse Response (FIR) filter. The individual responses of both filters are shown on the two top frequency spectrum responses. The HDF has a sinc/x type of a response and it does the initial filtering followed by the FIR that provides the desired stopband and transition band output characteristics. The cascaded final system response which is the actual output of the HSP43220 is shown on the bottom frequency response plot.

Besides the HSP43220 Harris has a number of other high speed Digital Filters that can be appropriate for under sampling applications. The reference part numbers for some of these filter products include the HSP43168, the HSP43124, the HSP43216 and the HSP50016. Information and more details of these Digital Filters as well as for other Digital Signal Processing (DSP) products can be found in the Harris DSP data book.