



Delta Modulation For Voice Transmission

Author: Don Jones

Introduction

Delta modulation has evolved into a simple, efficient method of digitizing voice for secure, reliable communications and for voice I/O in data processing.

To illustrate basic principles, a very simple delta modulator and demodulator are illustrated in Figure 1. The modulator is a sampled data system employing a negative feedback loop. A comparator senses whether or not the instantaneous level of the analog voice input is greater or less than the feedback signal. The comparator output is clocked by a flip-flop to form a continuous NRZ digital data stream. This digital data is also integrated and fed back to the comparator. The feedback system is such that the integrator ramps up and down to produce a rough approximation of the input waveform. An identical integrator in the demodulator produces the same waveform, which when filtered, reproduces the voice.

One can see that the digital data 0's and 1's are commands to the integrators to "go up" or "go down" respectively. Another way of looking at it is that the digital data stream also has analog significance; it approximates the differential of the voice, since analog integration of the data reproduces the voice.

Note that the integrator output never stands still; it always travels either up or down by a fixed amount in any clock period. Because of its fixed integrator output slope, the simple delta modulator is less than ideal for encoding human voice which may have a wide dynamic amplitude range.

The integrator cannot track large, high frequency signals with its fixed slope. Fortunately, human speech has statistically smaller amplitudes at higher frequencies, therefore an integrator time constant of about 1ms will satisfactorily reproduce voice in a 3kHz bandwidth.

A more serious limitation is that voice amplitude changes which are less than the height of the integrator ramp during one clock period cannot be resolved. So dynamic range is proportional to clock frequency, and satisfactory range cannot be obtained at desirable low clock rates.

A means of effectively increasing dynamic range is called "companding" (compressing-expanding); where at the modulator, small signals are given higher relative gain, and an inverse characteristic is produced at the demodulator.

The CVSD: A popular effective scheme for companded delta modulation is known as CVSD (continuously variable slope deltamod) shown in Figure 2. Additional digital logic, a second integrator, and an analog multiplier are added to the simple modulator.

Under small input signal conditions, the second integrator (known as the syllabic filter) has no input, and circuit function is identical to the simple modulator, except that the multiplier is biased to output quite small ramp amplitudes giving good resolution to the small signals.

A larger signal input is characterized by consecutive strings of 1's or 0's in the data as the integrator attempts to track the input. The logic input to the syllabic filter actuates whenever 3 or more consecutive 0's or 1's are present in the data. When this happens, the syllabic filter output starts to build up increasing the multiplier gain, passing larger amplitude ramps to the comparator, enabling the system to track the larger signal. Up to a limit, the more consecutive 1's or 0's generated, the larger the ramp amplitude. Since the larger signals increase the negative feedback of the modulator and the forward gain of the demodulator, companding takes place. By listening tests, the syllabic filter time constant of 4 to 10ms is generally considered optimum.

An outstanding characteristic of CVSD is its ability, with fairly simple circuitry, to transmit intelligible voice at relatively low data rates. Companded PCM, for telephone quality transmission, requires about 64K bits/sec data rate per channel. CVSD produces equal quality at 32K bits/sec. (However, at this rate it does not handle tone signals or phase encoded modern transmissions as well.)

CVSD is useful at even lower data rates. At 16K bits/sec the reconstructed voice is remarkably natural, but has a slightly "Fuzzy Edge". At 9.6K bits/sec intelligibility is still excellent, although the sound is reminiscent of a damaged loudspeaker. Of course, very sophisticated speech compression techniques have been used to transmit speech at even lower data rates; but CVSD is an excellent compromise between circuit simplicity and bandwidth economy.

Application Note 607

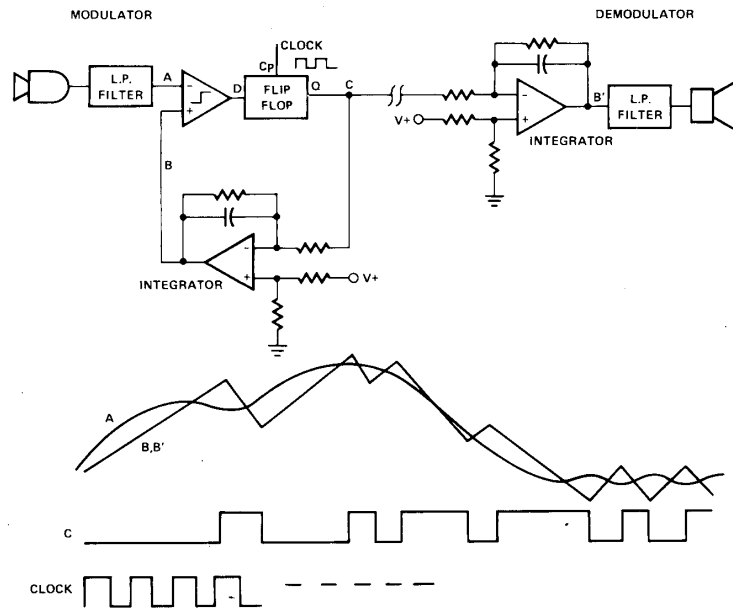

FIGURE 1.

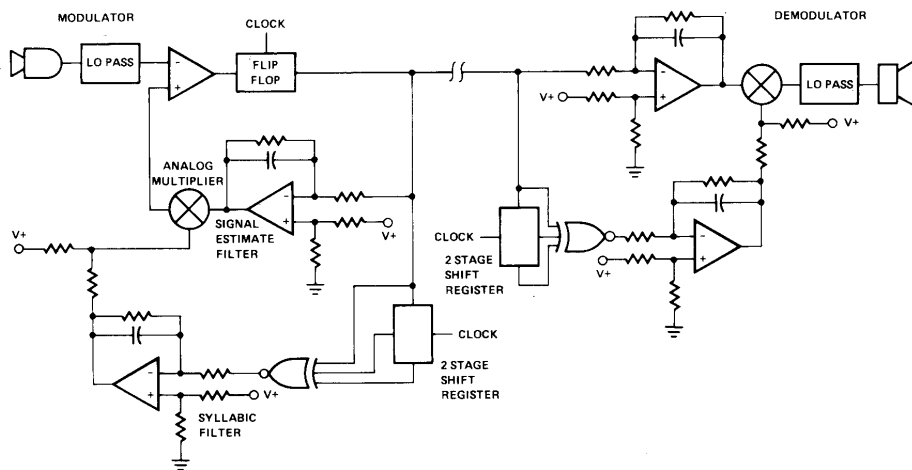

FIGURE 2.

The Digital CVSD

Delta modulated data is in a form which can be digitally filtered with fairly simple circuitry. A compatible CVSD can be made using digital integrators and multipliers driving a digital-to-analog converter. The block diagram of the HC-55564 monolithic CVSD is shown in Figure 3.

The CMOS digital circuit functions of Figure 3 closely parallel the equivalent analog function in Figure 2. The filters are single pole recursive types using shift registers with feedback. A digital multiplier feeds a 10-bit R-2R DAC which reconstructs the voice waveform. The DAC output is in steps, rather than ramps.

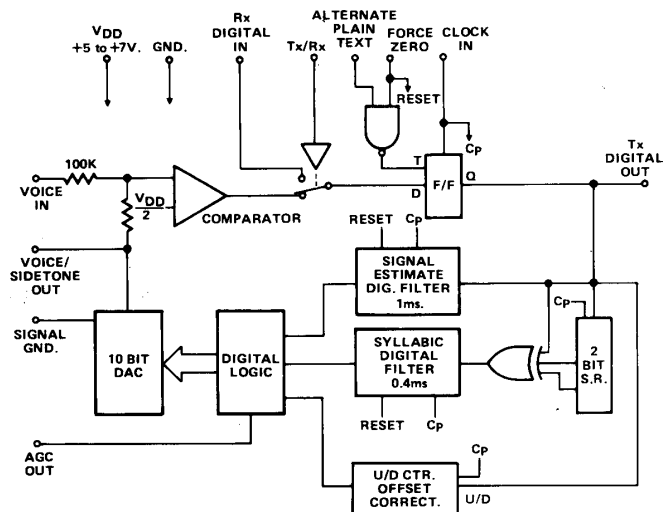

FIGURE 3. HC-55564 CVSD FUNCTIONAL DIAGRAM

The digital CVSD has a number of advantages over its analog counterpart, and has desirable features which would otherwise require additional circuitry:

- 1) The all CMOS device requires only 1mA current from a single +4.5V to +7V supply.
- 2) No bulky external precision resistors or capacitors are required for the integrators; time constants of the digital filters are set by the clock frequency and do not drift with time or temperature.
- 3) For best intelligibility and freedom from listener fatigue, it is important that the recovered audio is quiet during the pauses between spoken words. During quiet periods, an alternate "1", "0" pattern should be encoded, which when decoded and filtered will be inaudible. Achieving this in the analog CVSD requires that up and down ramp slopes are precisely equal and that offsets in the comparator and amplifiers are adjusted to zero. Improper adjustment or excessive component drift can result in noisy oscillations. In the digital design, comparator offset and drift are adjusted by a long up-down counter summed to the DAC to insure that over a period of time equal numbers of 1's and 0's are generated.

An added feature is automatic quieting, where if the DAC input would be less than 2 LSB's the quieting pattern is generated instead. This has proven to aid intelligibility.

- 4) To prevent momentary overload when beginning to encode or decode, it is desirable to initialize the integrators. In the analog CVSD, external analog switches would be required to discharge the capacitors.

In the digital CVSD, the filters are reset by momentarily putting the "Force Zero" pin low. At the same time, a quieting pattern is generated without affecting internal encoding by putting the "Alternate Plain Text" pin low.

- 5) In some analog CVSD designs, transient noise will be generated during recovery from a low frequency overdriven input condition. The digital CVSD has a clipped output with instant recovery, when overdriven.
- 6) Half-duplex operation (using the same device, switching between the encode and decode functions) requires external circuits with the analog CVSD, while the digital type is switched internally by a logic input.

Applications of Delta Modulation

- 1) **Telecommunications:** Digitized signals are easily routed and multiplexed with low cost digital gates. Voice channels may be easily added to existing multiplexed digital data transmission systems. The digital signals are much more immune to crosstalk and noise when transmitted over long distances by wire, R.F., or optical paths. CVSD has better intelligibility than PCM when random bit errors are introduced during transmission.
- 2) **Secure Communications:** Digital data can be quite securely encrypted using fairly simple standard hardware (Figure 4A). Scrambled speech for audio channels may also be accomplished by encoding into a shift register, then selecting different segments of the shifted data in pseudo-random fashion and decoding it (Figure 4B).

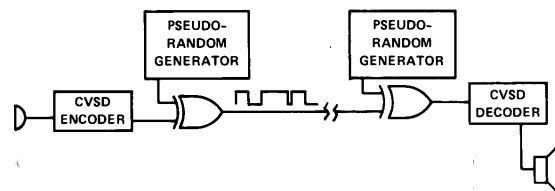

FIGURE 4A. DIGITAL TRANSMISSION ENCIPTION

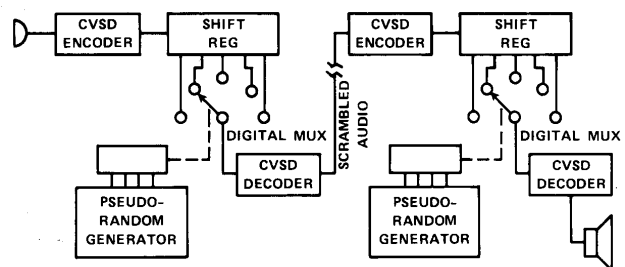

FIGURE 4B. VOICE TRANSMISSION SCRAMBLING

- 3) **Audio Delay Lines:** Although charge-coupled devices (CCD) will perform this function, they are still expensive and choice of configurations is quite limited. Also, there is a practical limit to the number of CCD stages, since each introduces a slight degradation to the signal.

As shown in Figure 5, the delay line consists of a CVSD modulator, a shift register and a demodulator. Delay is proportional to the number of register stages divided by the clock frequency. This can be used in speech scrambling, as explained above, echo suppression in PA systems; special echo effects; music enhancement or synthesis; and recursive or nonrecursive filtering.

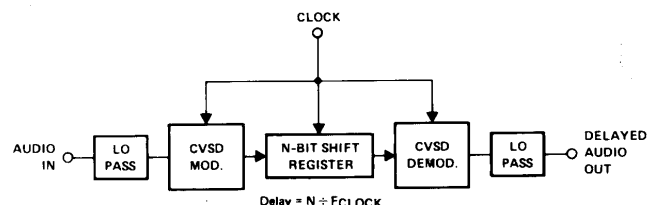

FIGURE 5. AUDIO DELAY LINE

Application Note 607

4) **Voice I/O:** Digitized speech can be entered into a computer for storage, voice identification, or word recognition. Words stored in ROM's, disc memory, etc. can be used for voice output. CVSD, since it can operate at low data rates, is more efficient in storage requirements than PCM or other A to D conversions. Also, the data is in a useful form for filtering or other processing.

Figure 6 illustrates a simple evaluation breadboard circuit for the HC-55564. A single device is sufficient to evaluate sound quality, etc. since, when encoding, the feedback signal at pin 3 is identical to the decoded signal from a receiver. The following are some pointers for using the devices:

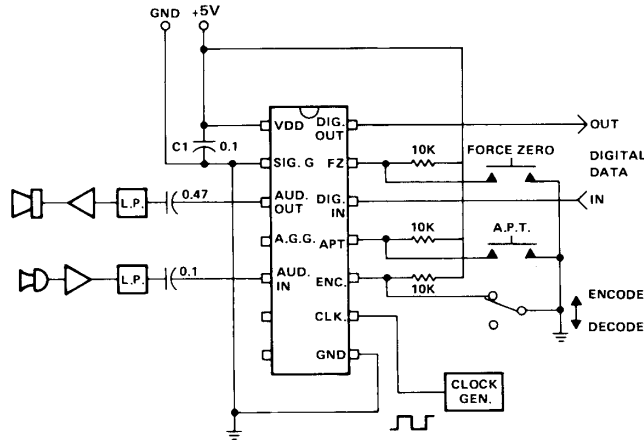

FIGURE 6. CVSD HOOKUP FOR EVALUATION

- 1) Power supply decoupling is essential with the capacitor (C1 in Figure 6) located close to the I.C.
- 2) Power to the I.C. must be present before the audio input, the clock, or other digital inputs are applied. Failure to observe this may result in a latchup condition, which is usually not destructive and may be removed by cycling the supply off, then on.
- 3) Signal ground (pin 2) should be externally connected to pin 8 and power ground. It is recommended for noise-free operation that the audio input and output ground returns connect directly to pin 2 and to no other grounds in the system. Pins 6 and 7 must be open circuited.
- 4) Digital inputs and outputs are similar to and compatible with standard CMOS logic circuits using the same supply voltage. The illustrated 10K pullup resistors are necessary only with mechanical switches, and are not necessary when driving these pins with CMOS. Unused digital inputs should be tied to the appropriate supply rail for the desired operation. TTL output, however, will require CMOS input levels. Pins 4 and 14 will drive CMOS logic, or each can drive one low power TTL input.

5) Capacitor coupling is recommended for the audio in and out (pins 3 and 5) as each pin is internally biased to about 1/2 the supply voltage.

6) The AGC output (pin 4) is a digital output, whose duty cycle is dependently on the average audio level. This may be externally integrated to drive an AGC preamplifier; or it could be used (through a buffer gate) to drive an LED indicator to indicate proper speaking volume.

7) To prevent generation of alias frequencies, the input filter should reduce the audio amplitude at frequencies greater than half the clock rate to less than $12mV_{P-P}$.

8) The PCM Filter shown in the data sheet lends itself well as a cost-effective input/output filter to the CVSD.

9) A suggested receiver clock circuit is a free running multi-vibrator, synchronized at each transition of the incoming data. Any synch errors occurring during reception of long strings of zeros or ones will have negligible effect on the decoded voice.

Figures 7 through 11 illustrate some typical audio output (before filtering) and digital output waveforms. To make the scope picture stationary, the audio input generator was synchronized with a submultiple of the clock frequency.

Figure 7 shows the results of a large low frequency sine wave. The somewhat jagged peaks are typical of all CVSD systems. Note that the digital output is continuous "ones" while the waveform is slewing down and continuous "zeros" while slewing up.

Figure 8 shows the excellent recovery from overdriven conditions at low frequency. Some analog type CVSD's have trouble recovering from this condition.

As mentioned previously, CVSD's cannot handle large signals at high frequencies (but these are not generally present in the human voice). Figure 9 shows this limitation where the voice output is slewing at its maximum rate, but cannot catch up with the input. At reduced amplitudes, however, the same signal can be reproduced, as shown in Figure 10.

The transfer function curve on the data sheet shows that at 16kHz clock rate, a $1.2V_{RMS}$ signal can be tracked up to 500Hz. With a 32kHz clock, the same curves may be used, but with each of the indicated frequencies doubled. Likewise, each of the SNR figures shown on the data sheet will be 6dB better than a 32kHz clock.

Figure 11 shows the 10mV voice output waveform at 1/2 the clock rate, when there is no audio input. After filtering, this signal is inaudible.

Application Note 607

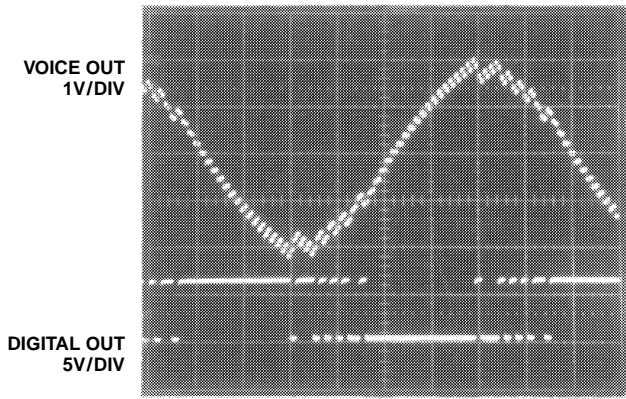

0.5ms/DIV
 VOICE IN = 250Hz, 4V_{p-p} SINE WAVE
 CLOCK = 16kHz

FIGURE 7. CVSD LARGE SIGNAL SINE WAVE RECONSTRUCTION

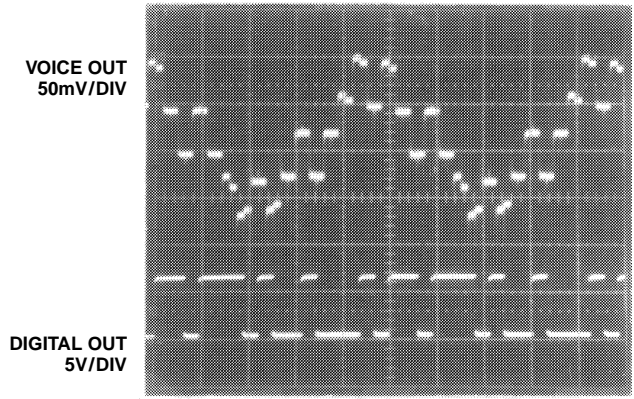

0.2ms/DIV
 VOICE IN = 1kHz, 0.15V_{p-p} SINE WAVE
 CLOCK = 16kHz

FIGURE 8. CVSD SMALL SIGNAL SINE WAVE RECONSTRUCTION

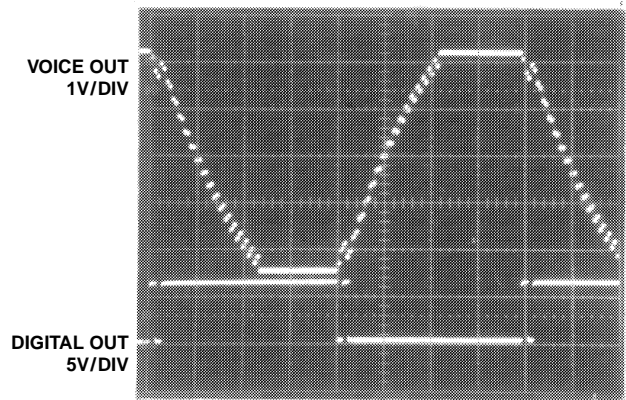

0.5ms/DIV
 VOICE IN = 250Hz, 6V_{p-p} SINE WAVE
 CLOCK = 16kHz

FIGURE 9. CVSD LARGE SIGNAL, LOW FREQUENCY CLIPPED WAVEFORM

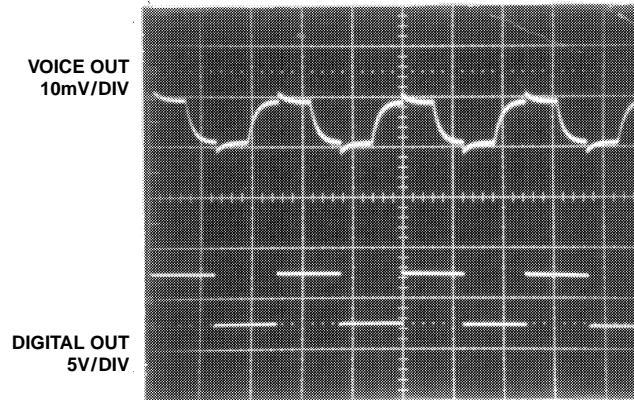

50ms/DIV
 VOICE IN = 0
 CLOCK = 16kHz

FIGURE 10. CVSD ZERO SIGNAL IDLE PATTERN

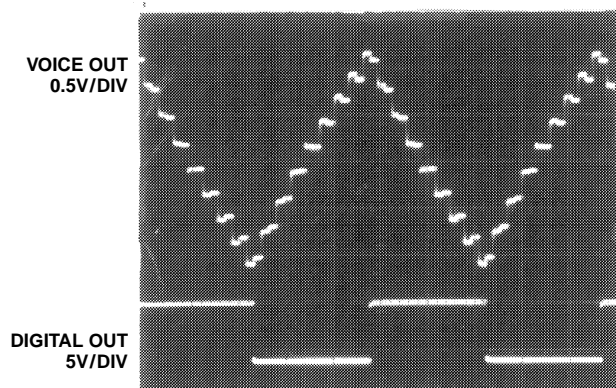

0.2ms/DIV
 VOICE IN = 1kHz, 6V_{p-p} SINE WAVE
 CLOCK = 16kHz

FIGURE 11. CVSD LARGE SIGNAL, HIGH FREQUENCY SLEW LIMITING