

DYNAMIC PERFORMANCE TESTING OF DIGITAL AUDIO D/A CONVERTERS

By Larry Gaddy and Hajima Kawai

This application bulletin will provide the reader with an understanding of test methods for audio digital-to-analog converters (DACs). In particular, delta-sigma ($\Delta\Sigma$) DACs require a special understanding due to the nature of their architecture. The dynamic specifications of interest for an audio DAC are THD+N (total harmonic distortion + noise), dynamic range, channel separation, and idle channel noise (often referred to as SNR, signal-to-noise ratio). There are many possible digital audio applications, but only CD-DA (reproduction of digital audio from a compact disc) has a standard specification defined by EIAJ (Electronic Industry Association of Japan). Test methods for evaluating DACs used in other digital audio applications are somewhat ambiguous. For these applications, evaluating the DAC is highly dependent upon the experience and knowledge base of the design engineer. Digital audio reproduction is based upon sampling and Nyquist theorems. This application bulletin will describe the operation theory of $\Delta\Sigma$ audio DACs, and associated test methods for these DACs.

SAMPLING AND NYQUIST THEOREMS

Digital audio can be reproduced when the data obeys the Nyquist criteria. This criterion states any signal can be completely described when the bandwidth of the sampled signal is less than one half of the sampling frequency. For a DAC, this means the sampling frequency must be at more than twice the value of the highest frequency for reproduction. Figure 1a illustrates proper sampling technique, where the sampling frequency f_s is more than twice the value of the frequency of interest f_A . In figure 1b, f_s is less than $2f_A$, violating the Nyquist sampling theorem and creating signal aliasing. The frequency spectra shown in figures 1a and 1b represent the reconstructed analog signals. CD players use a sampling frequency of 44.1kHz, which allows for reproduction of signals up to 22.05kHz, more than the accepted upper audio bandwidth limit of 20kHz.

OUTPUT SPECTRA IS DEPENDENT UPON DAC ARCHITECTURE

There are two primary DAC architectures used in digital audio applications: R-2R and $\Delta\Sigma$. Consumer-level and cost-sensitive applications tend to use $\Delta\Sigma$ DACs, which have higher integration and lower cost. The $\Delta\Sigma$ DAC is also known as noise-shaping or one-bit DACs. In most cases, the original 16-bit audio data is digitally filtered and interpolated. This filtering function is external for most R-2R DACs and internal to most $\Delta\Sigma$ DACs.

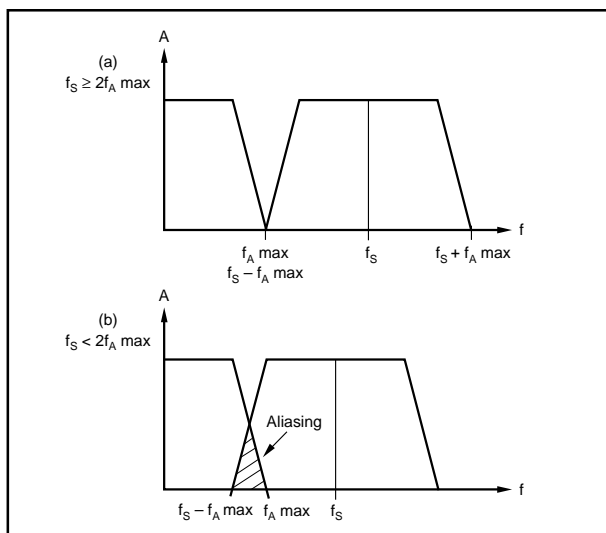

FIGURE 1. Sampling Theorem and Nyquist Theorem.

OUTPUT SPECTRA FOR AN R-2R DAC

Early generation digital audio was reproduced using R-2R type DACs, sometimes called current-steering or ladder DACs. The architecture for the R-2R DAC is very similar to instrumentation-grade DACs, where all bits are converted simultaneously (although these DACs accept standard serial digital audio data, they utilize internal serial-to-parallel converters). This architecture is used in Burr-Brown's audio DACs such as PCM56, PCM61, PCM63, PCM1700 and PCM1702. This architecture has a theoretical noise limit equivalent to the random quantization noise contained in the digital audio data. The R-2R DAC does not contain any internal filtering or noise shaping. In practice, the noise floor is limited by analog noise sources, such as resistor noise and $1/f$ noise. These noise sources are typically less than -100dB , as shown in Figure 2.

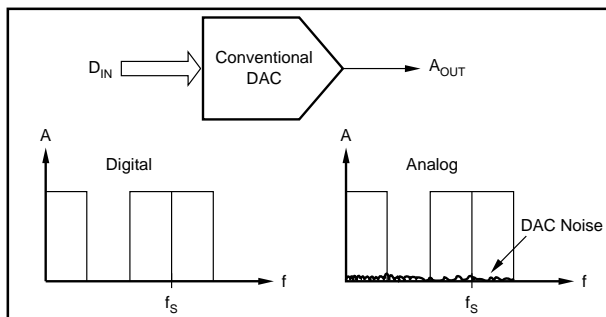

FIGURE 2. Output Spectrum for an R-2R DAC.

In a typical application, the output of the R-2R DAC is filtered, using an analog low-pass filter. This filter acts as an anti-imaging filter rejecting signals which fall outside of f_A , as shown in Figure 3. The analog filter must pass all signals up to f_A , typically 20kHz for audio, and reject all frequencies beyond f_A . In practice, these filters have some small roll-off prior to 20kHz with finite stop-band attenuation, though these “imperfections” are rarely audible.

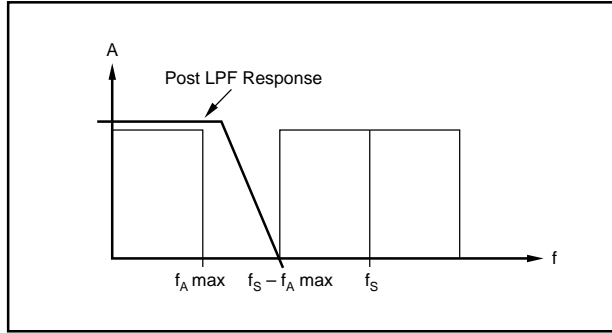

FIGURE 3. Bandlimiting with a Low Pass Filter.

OUTPUT SPECTRA FOR AN OVERSAMPLING DIGITAL FILTER

Most modern digital audio applications, whether an R-2R or $\Delta\Sigma$ DAC is used, include an oversampling digital filter function. The original purpose of the digital filter was to reduce the performance requirements of the analog post low-pass filter by increasing the sampling rate. A practical explanation of the operation and theory of the digital filter leads to an understanding of the relationship between the low-pass filter test condition and the output spectrum of the DAC.

A digital filter for an audio DAC interpolates the input data, and then filters the data with a finite impulse response (FIR) function, which is similar to an analog low-pass filter. The interpolation function is also known as oversampling. Shown in Figure 4 are the original input spectra (4a), the 2-times interpolated spectra (4b), and the interpolated spectra with FIR filtering. In this example, the original input data is oversampled 2-times, leading to the spectra shown in 4b, which contains additional data around $2f_s$. Next, the data is filtered by the digital FIR, with the result shown in Figure 4c. The level of attenuation in the stopband is given by the order, or number of taps, in the digital filter.

It is important to understand the stopband attenuation of the digital filter. There are many types of digital filters offering a wide variety of performance. The level of attenuation may vary from -30dB to -100dB . As shown in Figure 4c, a higher level of attenuation from the digital filter will reduce the performance requirements of the post low-pass filter. For the sake of simplicity, this section used a 2-times oversampling rate as an example. In practice, 4-times or 8-times oversampling are more common. These filters are implemented by cascading stages of interpolation and filtering.

OUTPUT SPECTRA OF A $\Delta\Sigma$ DAC

$\Delta\Sigma$ DACs utilize a different approach for obtaining dynamic range performance compared to R-2R DACs. The in-band (audio band) quantization noise is reduced by delta-sigma modulation and by oversampling the input spectrum at a rate much greater than for R-2R DACs. This noise-shaping performance is given by the order of the modulator as well as the oversampling rate. These factors determine the dynamic range capabilities of the $\Delta\Sigma$ DAC. The spectrum for a typical $\Delta\Sigma$ modulator is shown in Figure 5, with the audio band area of interest highlighted as f_A . Observe how the noise is “shaped” to the out-of-band region.

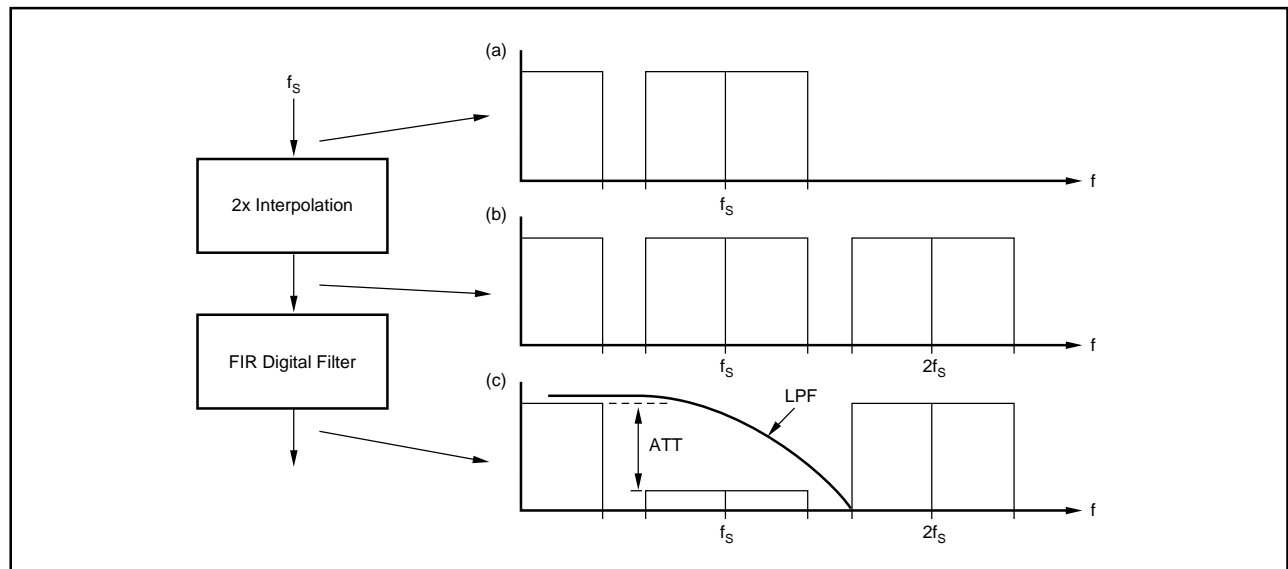

FIGURE 4. Function and Operation of a Digital Filter .

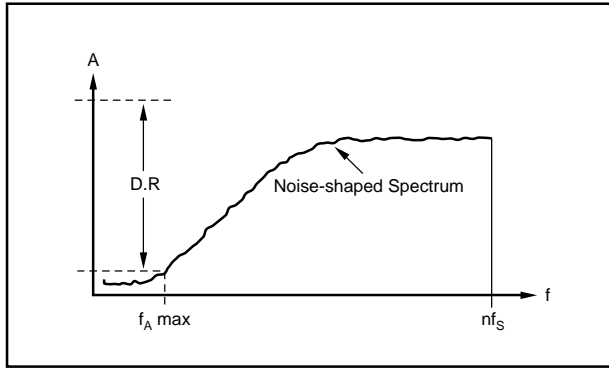

FIGURE 5. $\Delta\Sigma$ Noise Shaper Spectrum.

The $\Delta\Sigma$ DAC is typically integrated with the digital filter, providing a monolithic solution. For these DACs, the output spectrum is given by the combined performance of the digital filter and the $\Delta\Sigma$ DAC, including the level of stop-band attenuation provided by the digital filter. The complete $\Delta\Sigma$ output spectrum is shown in Figure 6.

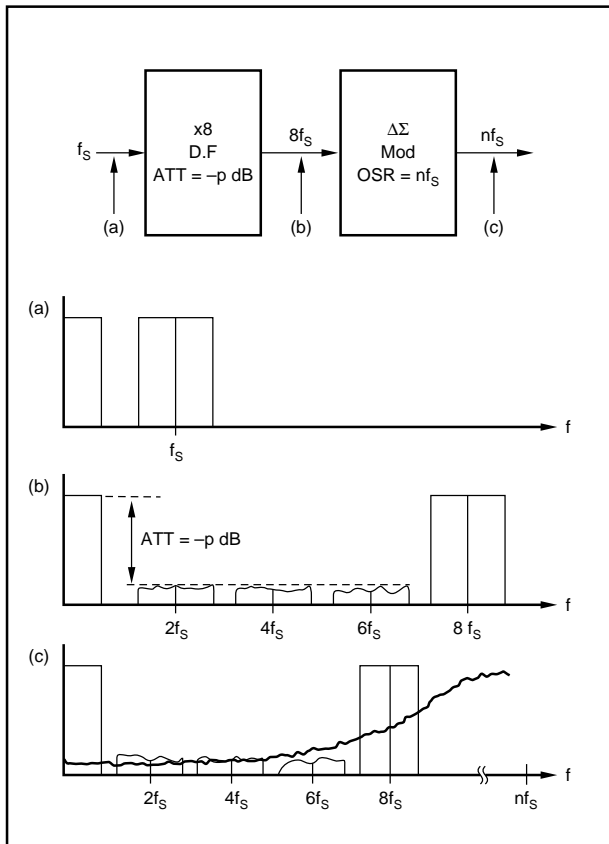

FIGURE 6. Spectrum of a $\Delta\Sigma$ DAC with a Digital Filter.

DYNAMIC PERFORMANCE TESTING

An audio DAC is primarily evaluated for dynamic performance. DC specifications are not important, since DC cannot be heard! This section will define and discuss test methods for dynamic performance.

TOTAL HARMONIC DISTORTION PLUS NOISE (THD+N)

Total harmonic distortion plus noise is related to the linearity errors of the DAC, as well as the level of in-band noise. Human hearing is highly sensitive to distortion and noise present in audio playback systems. As shown in Figure 7, when the audio signal is reconstructed from the digital source data, harmonic distortion occurs at both even and odd harmonics of the fundamental signal. The sum of these harmonics is defined as the total harmonic distortion, though in practice the sum is limited to seven or nine harmonic terms. For the complete term THD+N, the in-band (audio bandwidth of 20Hz to 20kHz) noise term is included. Given this, any noise beyond 20kHz should be rejected from consideration in the noise term. Only noise in the passband from 20Hz to 20kHz should be considered. If the measurement for THD+N is not bandlimited to 20kHz, the out-of-band noise will be included in the THD+N term, and will not be a true measurement of audio THD+N. Distortion is generally measured against amplitude (signal level) and frequency.

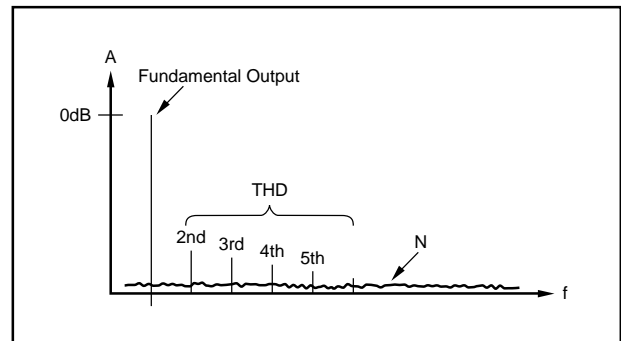

FIGURE 7. Harmonic Distortion Spectrum.

DYNAMIC RANGE

The EIAJ standard measurement for dynamic range is done by reading THD+N at an input amplitude of -60dB . The measured value is negative, since the distortion level will be down from the fundamental amplitude. Dynamic range is calculated by inverting the polarity of the THD+N reading, and adding 60dB. Theoretical dynamic range performance is limited by resolution, which determines the quantization error level:

$$\text{Dynamic Range} = 6.02n + 1.76, \text{ in dB}$$

n = number of bits of resolution

Given this equation, the theoretical limit for dynamic range for a 16-bit DAC is approximately 98dB. In practice, dynamic range is degraded by nonlinearities and semiconductor noise sources, as well as by actual resolution. Dynamic range is perhaps the most useful figure of merit for an audio DAC, as it indicates the DAC's ability to reproduce low level signals. Human hearing is much more sensitive to distortion at very low signal levels than at large amplitudes. Dynamic range is usually specified as A-weighted, which compen-

sates for human hearing response. Psychoacoustic studies have characterized human hearing, which is not flat over audible frequencies. There is a predictable response pattern which is called A-weighted. This response phenomena is applied to the output spectrum of the DAC. Generally speaking, A-weighted data will be 2 to 3dB better than non-weighted. Since the application for the audio DAC is almost always audio reproduction, it makes sense to apply A-weighting to the results.

SIGNAL-TO-NOISE RATIO (SNR)

SNR is often misused in defining audio DAC performance. For an A/D converter, SNR is a figure of merit similar to the dynamic range of a DAC, being limited by the resolution. For a DAC, SNR is measured with all input data set to zero. In this case, the output will consist of any noise sources in the DAC, totally independent of the resolution. A more proper term to describe the noise floor for an audio DAC is idle channel noise. This specification is also typically A-weighted. A comparison of the dynamic range and idle channel noise floors is shown in Figure 8.

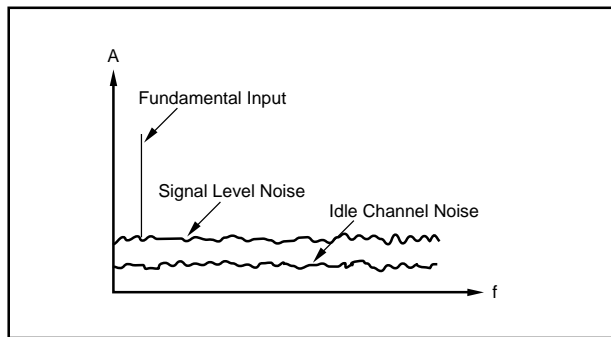

FIGURE 8. Noise Levels.

There is a special case for measuring SNR for a $\Delta\Sigma$ DAC: depending upon the quality of the design architecture, the output of a $\Delta\Sigma$ DAC will not stay at a nominal analog zero level when given all zero input data. There is a tendency for the analog value to modulate around the zero output level. This may cause audible noise between CD tracks, for example. Most $\Delta\Sigma$ DACs contain a feature called zero detection or auto mute. When the input data is consistently zero (most DACs count for 8192 zeroes, Burr-Brown's DACs count for 65,536 consecutive zeroes) the output amplifier is disconnected from the delta-sigma modulator. In some cases, this results in an abrupt change in the noise floor, which may be heard as a "pop" or "click" in the output. Burr-Brown's PCM1717, 1718, 1719, 1720, 1721 utilize an advanced DC dither technique in the modulator. Primarily intended to eliminate idle tones, this dither technique also reduces modulation noise with zero input data. Typical performance for idle channel noise is 100dB, which eliminates the need for the zero detection feature (although this series of DACs still contain this feature as an option).

CHANNEL SEPARATION

Channel separation is defined as the ratio of the signal level on one channel while the opposite channel is held at idle level. In other words, this is a measure of crosstalk between adjacent channels. It can be measured by evaluating distortion on the idle channel when the opposite channel has data present. Channel separation is an indicator of stereo separation for the DAC.

THD+N at 0dB (full scale)	-88dB
THD+N at -60dB	-36dB
Dynamic Range	96dB
SNR (without zero detect)	100dB
SNR (with zero detect)	110dB
Channel Separation	96dB

TABLE I. Typical Dynamic Performance for PCM1717.

TEST METHODS FOR MEASURING DYNAMIC PERFORMANCE

For audio DACs, the noise spectrum for the DUT must be considered when establishing test conditions. The level of noise outside of normal audio frequencies is determined by the architecture, most often by the attenuation level of the digital filter. A proper test for an audio DAC includes band-limiting the measured spectra to the Nyquist frequency. Although this condition should be imposed upon all DAC testing, it is most important for $\Delta\Sigma$ audio DACs. If the measured output spectra is not band-limited, then the out-of-band noise will corrupt the dynamic range and idle channel noise results. Figure 9a illustrates the use of a high-order "brick-wall" low-pass filter, while Figure 9b shows an inadequate low-pass filter.

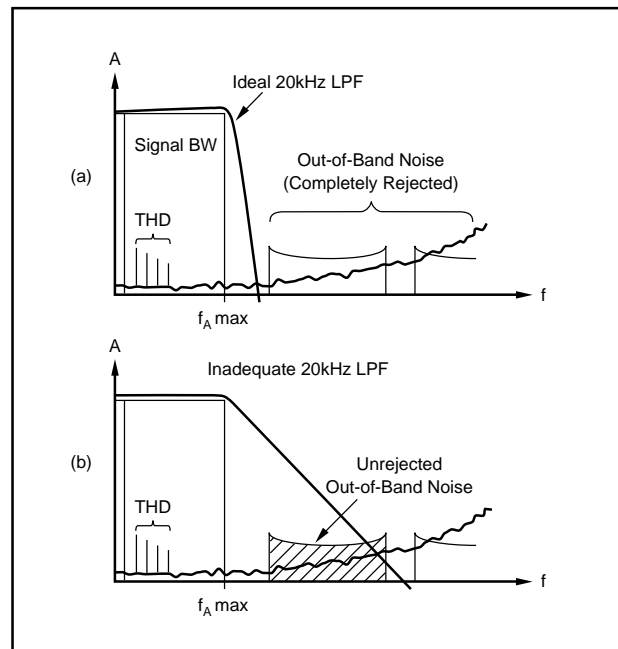

FIGURE 9. Requirements for External Low Pass Filter.

In Figure 9a, the out-of-band spectra is adequately rejected for f_A (maximum) = 20kHz. The portion of the out-of-band spectra is small enough so as not to interfere with in-band measurements of THD+N, etc. In Figure 9b, the rolloff of the filter is too gradual to adequately filter unwanted out-of-band noise. A measurement taken with this filter would show poor THD+N, etc., due to the inclusion of high levels of out-of-band noise. As shown, the low-pass filter must have enough stopband attenuation to remove the out-of-band noise components. This strictly applies for testing and evaluation purposes. For the actual application, a simpler filter may be inadequate, since the human ear makes an excellent low-pass filter with very steep infinite stopband attenuation. The only concern with out-of-band noise in an application is potential damage to downstream components.

REQUIRED PERFORMANCE FOR THE EXTERNAL LOW-PASS FILTER

The typical THD+N performance for audio DACs is between -80dB (0.01%) and -90dB (0.003%). Adequate measurement to this level would require -90dB attenuation in the stopband. The necessary performance levels for the low pass filter are illustrated in Figure 10, assuming $f_S = 44.1\text{kHz}$, and $f_A = 20\text{Hz}$ to 20kHz. From the Nyquist theorem, the sampling spectrum is distributed at $f_S - f_A$ (max), typically 24.1kHz (44.1kHz - 20kHz). The external low pass filter will further attenuate the out-of-band noise, depending upon the rolloff characteristic of the external filter.

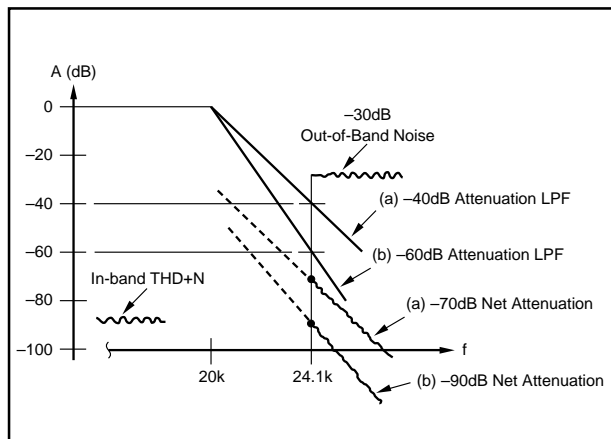

FIGURE 10. Test Results Due to Low Pass Filter .

From Figure 10a: External LPF (-40dB at 24.1kHz) attenuates -30dB noise to -70dB.

From Figure 10b: External LPF (-60dB at 24.1kHz) attenuates -30dB noise to -90dB.

Considering the typical $\Delta\Sigma$ DAC has a THD+N performance of -80dB to -90dB, it can be seen the -60dB attenuation LPF is adequate for testing purposes, while the -40dB filter would be inadequate for proper suppression of out-of-band noise. To realize actual dynamic performance, it is recommended to apply an external LPF which combined with the digital filter of the DAC will achieve -90dB attenuation

EIAJ CD PLAYER TESTING METHOD

EIAJ has specified a standard test for dynamic performance of CD players in 1985, reference number CP-307. The current standard is CP-2404. This test standard is also acceptable for general purpose testing of audio DACs. The conditions of CP-2404 are:

Passband	4Hz to 20kHz
Stopband Attenuation	-60dB at 24.1kHz

In addition, EIAJ specifies dynamic range and idle channel noise tests are A-weighted.

THD+N TEST

The block diagram for the THD+N test is shown in Figure 11. This diagram indicates the presence of the 20kHz LPF.

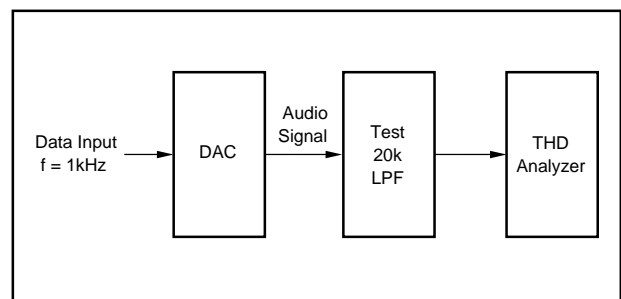

FIGURE 11. Block Diagram for THD Test.

DYNAMIC RANGE TEST

The block diagram for the dynamic range test is shown in Figure 12. The input signal to the DAC is set to -60dB. The output is then filtered with both a low-pass and A-weighting function. The output level is then amplified with a 60dB gain amplifier. The amplifier is used to provide a higher signal level for the spectrum analyzer. The THD+N is measured, the result being EIAJ standard dynamic range (expressed as a positive number). Figure 12 is a block diagram of the dynamic range test condition.

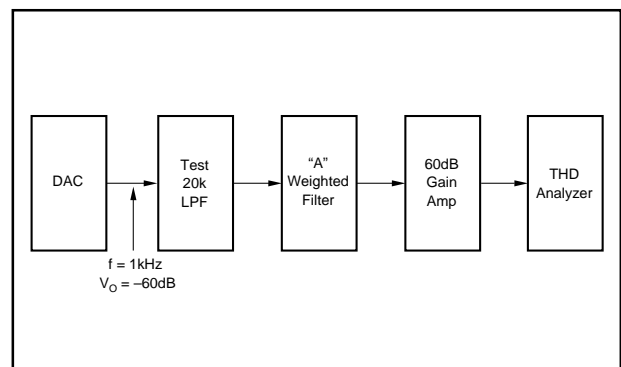

FIGURE 12. Dynamic Range Test Block Diagram.

SIGNAL-TO-NOISE (SNR) TEST

As previously mentioned, SNR is actually a measure of idle channel noise, since the test is measured with no input data present. The block diagram for the SNR test is shown in Figure 13. SNR is defined as the ratio of the full scale (0dB) signal level to the idle channel noise level:

$$\text{SNR} = \text{Signal Level (full scale)} - \text{Signal Level (idle input)}$$

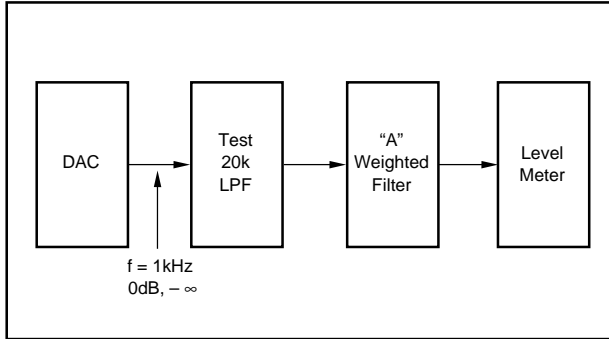

FIGURE 13. SNR (idle channel noise) Test Block Diagram.

CONSIDERATIONS FOR APPLICATIONS CIRCUITS

The general digital audio application utilizes a data source, the DAC under test, a low-pass filter and an analog audio amplifier, as shown in Figure 14.

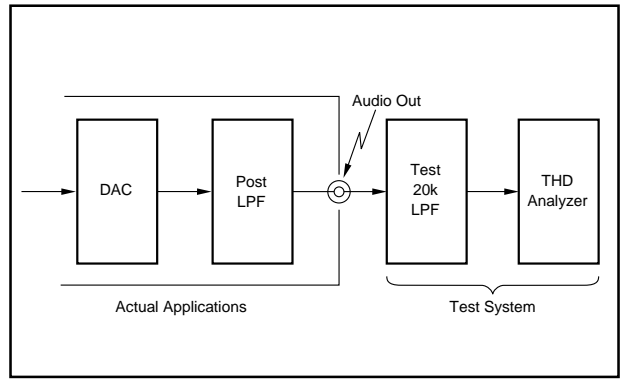

FIGURE 14. Actual Application and Test System.

Ideally the low-pass filter should have infinite rejection at 20kHz, as was previously discussed for test conditions. Most modern cost-sensitive applications do not, and cannot, use an exotic high-order low pass filter. These applications take advantage of psychoacoustics which use the natural “brick wall” filter characteristic of the human ear. Assuming the spectrum level for frequencies greater than 20kHz is at least -60dB, there is a little chance for damage to downstream equipment or audible noise. A typical application uses a low order filter cutoff frequency at 24kHz. Shown in Figure 15 are three examples of post low pass filters, a first-order passive RC, a second-order active, and a third-order active. All three filters use 24kHz as $f_c = -6\text{dB}$.

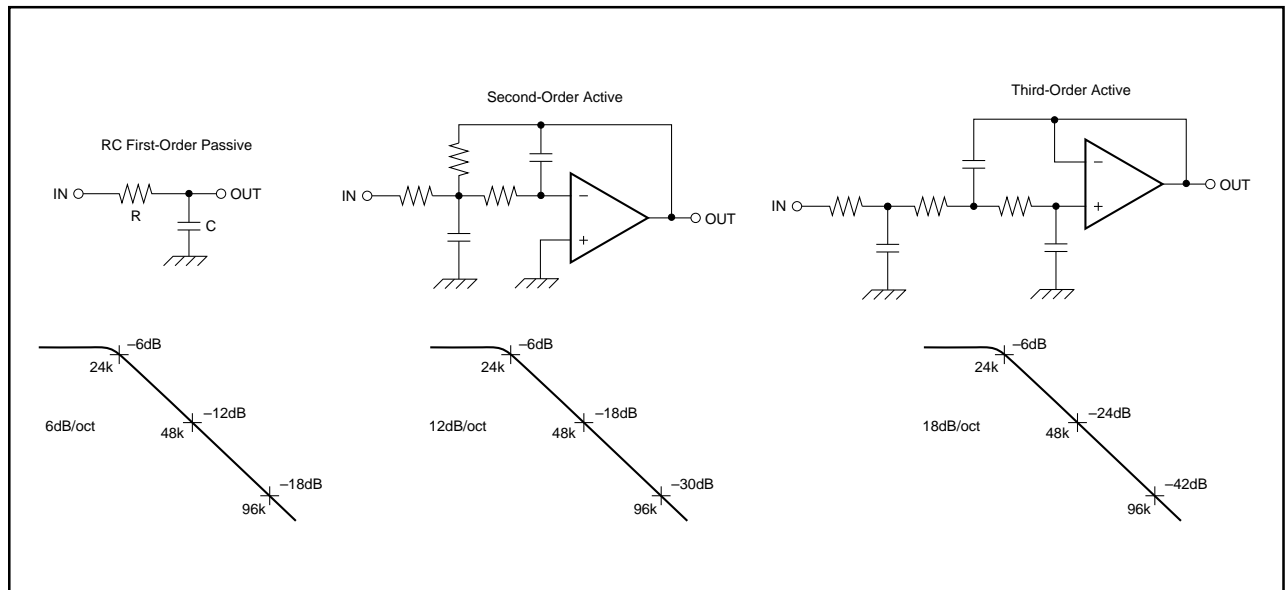

FIGURE 15. Performance of Typical Low Pass Filters.

The information provided herein is believed to be reliable; however, BURR-BROWN assumes no responsibility for inaccuracies or omissions. BURR-BROWN assumes no responsibility for the use of this information, and all use of such information shall be entirely at the user's own risk. Prices and specifications are subject to change without notice. No patent rights or licenses to any of the circuits described herein are implied or granted to any third party. BURR-BROWN does not authorize or warrant any BURR-BROWN product for use in life support devices and/or systems.

EXAMPLES OF ACTUAL MEASUREMENTS

Figure 16 is an example of an actual measured output spectrum for a $\Delta\Sigma$ DAC. This is the output of Burr-Brown’s PCM1717E, sampling at 44.1kHz. The input data is a 16-bit digital approximation of a 1kHz sinewave. The noise in the spectrum is limited by the noise shaper. For PCM1717 and PCM1718, the noise floor with a full scale input is around -74dB . In Figure 16a, the input signal is a full scale 1kHz sinewave. The input signal is aliased around the sampling frequency of 44.1 kHz. The amplitude of the alias signal is limited by the digital filter. The PCM1717 data sheet indicates a stopband attenuation level of -35dB ; this is the minimum level. Since the digital filter’s response is frequency dependent, the attenuation level will vary. In this example, the 1kHz alias signals are attenuated to -45dB .

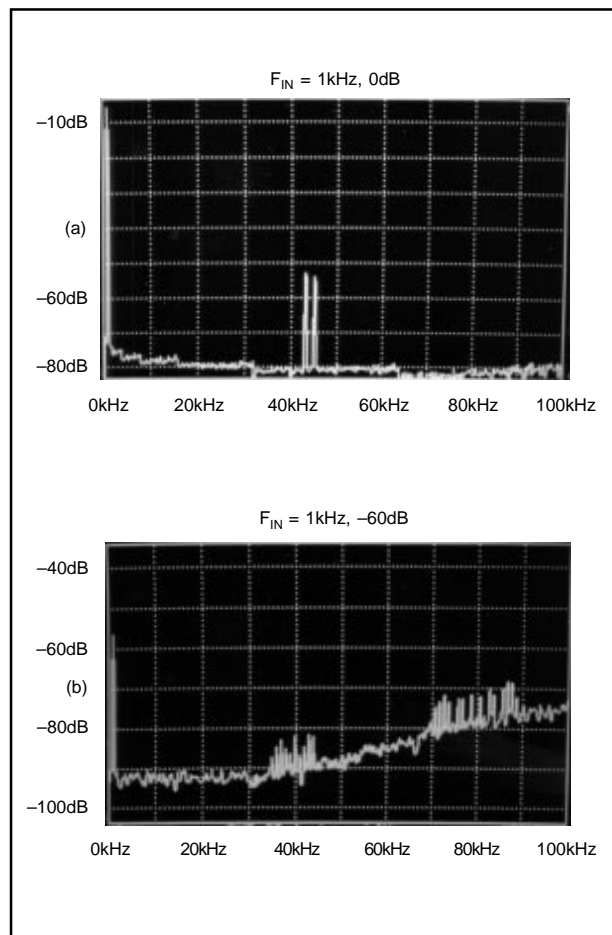

FIGURE 16. PCM1717 Output Spectrum.

In Figure 16b, the input is very low level, at -60dB . Now the effect of the noise shaped spectrum can easily be seen. The in-band noise floor is around -94dB . At 100kHz , the noise level is at -75dB . The amplitude of the alias frequencies is at -80dB . In the test environment, this noise must be suppressed to at least -95dB to yield proper results.

THD+N TEST CONDITIONS

The effect of external low pass filters on test results can be quite dramatic. Two pieces of test equipment can be used for demonstration purposes, Audio Precision’s “System One” and Shibasoku’s “Model 725 THD Meter”. All data is measured using the PCM1717.

SYSTEM ONE

The System One has several types of internal filters, at 22kHz, 30kHz and 80kHz, which are often assumed to be adequate. For duplicating data sheet results, these internal filters do not have steep enough rolloff. In Figure 17, both the System One’s 22kHz internal filter and a high-order 20kHz external filter are used. The two curves, which appear to have very little difference between them show the direct output of the DAC and a filtered (second-order) output, as used on the PCM1717 evaluation board, DEM-DAI1717. Note the full scale THD+N is at -88dB , as indicated in the PCM1717 data sheet.

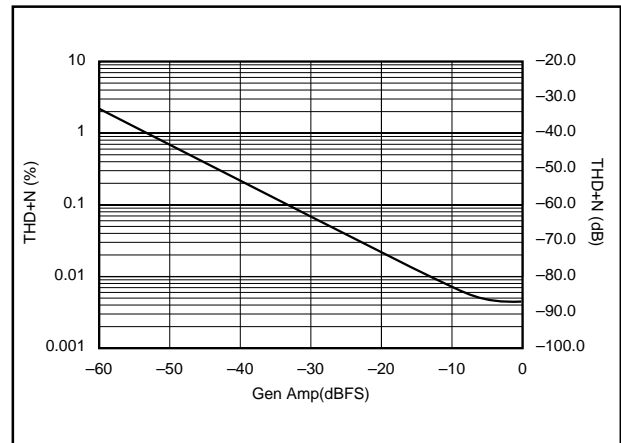

FIGURE 17. PCM1717 THD+N with External 20kHz LPF.

In Figure 18, the System One 22kHz filter is used but with no additional external 20kHz filter. Both the direct output and the filtered output are examined, as in Figure 17. The filtered output appears to have reasonable THD+N performance, but note how the full scale data point is at -76dB . This is caused by inadequate suppression of out-of-band noise by the System One and DEM-DAI1717 low pass filters; more rolloff is required. For the direct output, the noise level was so high the measurement is completely meaningless. This figure illustrates the need for a high-order low pass filter.

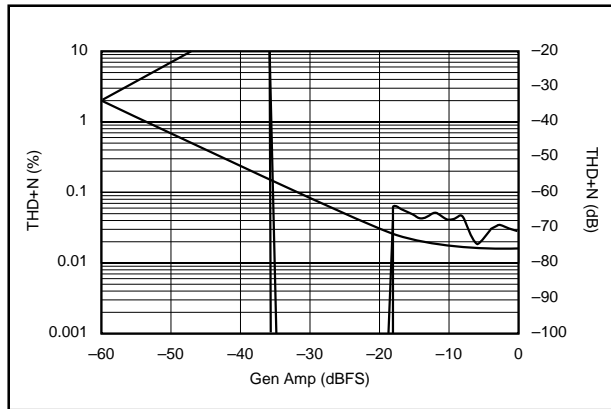

FIGURE 18. PCM1717 THD+N with No External Filter.

SHIBASOKU 725 THD METER

The Shibasoku 725 distortion analyzer also has internal low pass filters at 30kHz and 100kHz. The rolloff of these filters is no more adequate than for the System One's filters. Each scope photo shows the output signal from the DAC as a reference, and the level of distortion measured on that signal. In Figure 19a, an external 20kHz filter is used in addition to the Shibasoku's internal filter, and the output of the DAC is filtered on DEM-DAI1717. The measured THD+N is -91dB. In Figure 19b, the external filter is

removed. The measured THD+N is -60dB. In Figure 19c, the Shibasoku filter is used with the direct output of the DAC. The measured THD+N is -42dB. Note how the distortion is visible on the reference signal. Clearly the performance of the Shibasoku 30kHz filter is too poor for test purposes.

SUMMARY

The multi-level $\Delta\Sigma$ architecture used in Burr-Brown's PCM17xx audio DAC family has higher out-of-band noise than traditional one-bit switched capacitor DACs. The multi-level architecture is used to provide lower in-band noise, which is much more important for the actual application. The data sheet performance specifications are achieved through use of a high-order low pass filter which provides -60dB attenuation at 24.1kHz. If the DAC is measured without an adequate low pass filter, then the THD+N figure will include some out-of-band noise. Since THD+N for an audio DAC is defined as measured between 20Hz and 20kHz, it would not be proper to allow noise greater than 20kHz to interfere with the measurement. Proper evaluations must include a high performance external low pass filter. The most important elements to consider when designing a performance evaluation solution are 20kHz bandlimiting and the Nyquist sampling theorem.

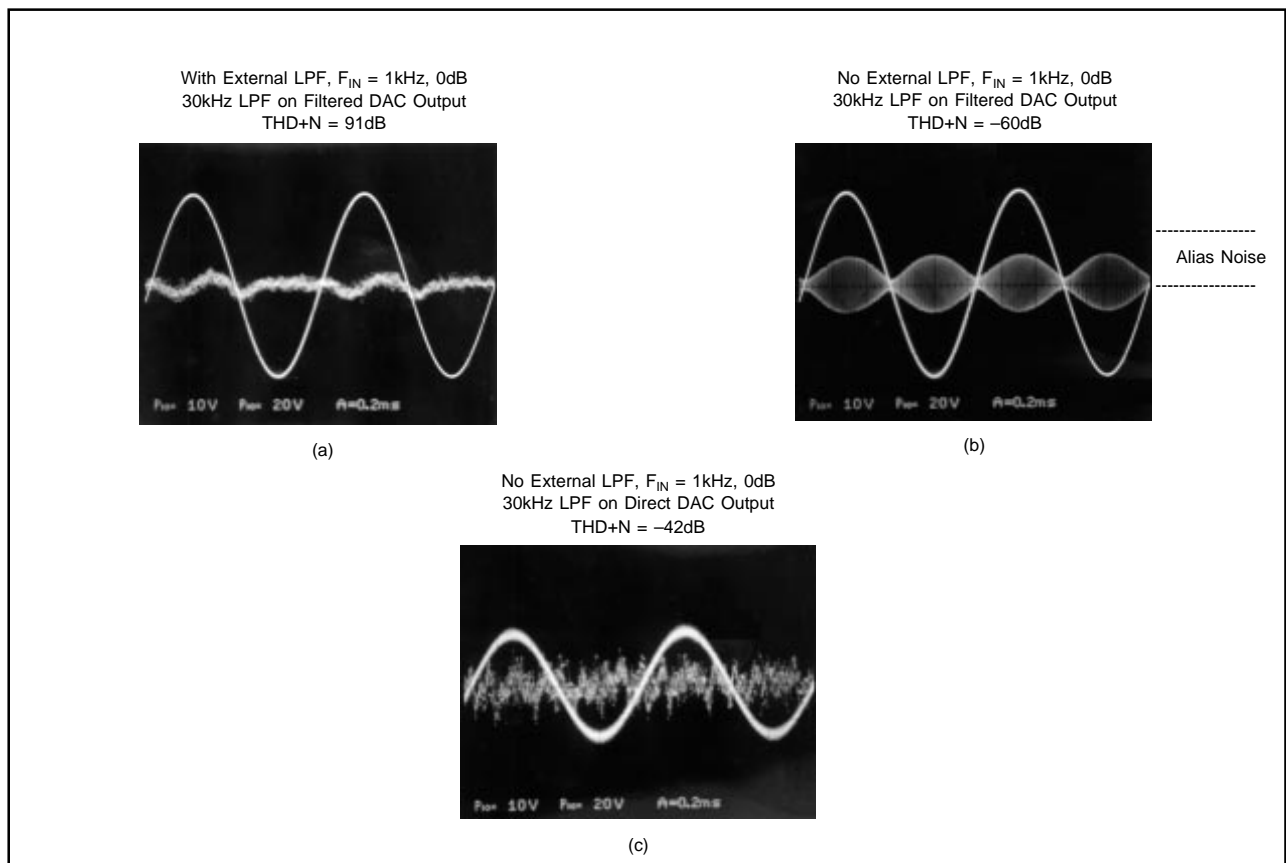

FIGURE 19. PCM1717 THD+N From Shibasoku 725 THD Analyzer.