

DIGITALLY PROGRAMMABLE, TIME-CONTINUOUS ACTIVE FILTER

by Johnnie Molina, (602) 746-7592

Programmable active filters have increased in popularity over the past decade. With the advent of switched capacitor topologies, filter parameters such as the natural frequency and filter Q can be changed simply by varying the clock frequency. But switched capacitor filters are sampled data systems and are subject to anomalies such as clock feedthrough noise and aliasing errors.

The circuit in Figure 1 shows how an analog, digitally programmable filter can be built using a UAF42. This monolithic, state-variable active filter chip provides a two pole filter building block with low sensitivity to external component variations. It eliminates aliasing errors and clock feedthrough noise common to switched capacitor filters. Lowpass, highpass, bandpass and notch (band reject) outputs are available simultaneously.

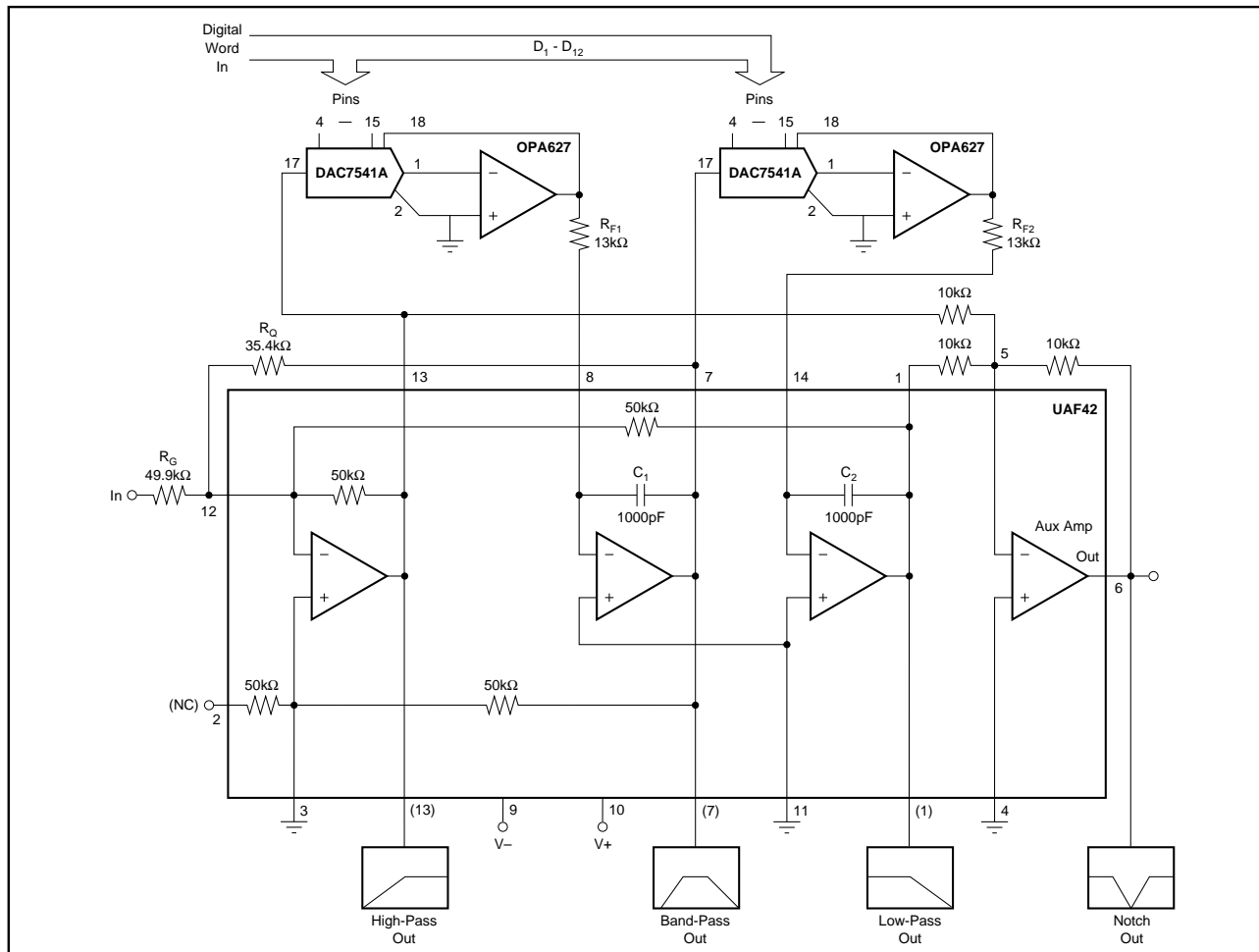

FIGURE 1. Digitally Programmable Analog Filter.

The circuit uses the UAF42 state-variable filter IC, two op amps, a few resistors and two common MDACs. Capacitors aren't required because the UAF42 has on chip 1000pF, 0.5% precision capacitors. The MDACs function as voltage attenuators which influence the unity-gain bandwidth of the integrators on board the UAF42. The filter's natural frequency, f_o , is described by the following relationships:

$$f_o = \text{DAC}_{\text{GAIN}} \cdot f_{o_{\text{MAX}}} \quad (1)$$

Where:

$$\text{DAC}_{\text{GAIN}} = \frac{X}{2^n}$$

$$f_{o_{\text{MAX}}} = \frac{1}{2 \cdot \pi \cdot 10^{-9} \cdot R_F} \quad R_F = R_{F1} = R_{F2}$$

and,

X = digital word at DAC inputs $D_1 - D_{12}$

n = number DAC bits

BUILD A NOTCH FILTER

For example, to program a 60Hz notch filter with the circuit shown in Figure 1, the digital word to the MDAC is given using Equation 1,

$$X = 6.28 \cdot 10^{-9} \cdot R_F \cdot f_o \cdot 2^n$$

Given that,

$$f_o = 60 \quad R_F = 13\text{k}\Omega \quad n = 12$$

then,

$$X = 20.1$$

The 12-bit digital word to the DAC should be 20 or 00000010100. The rounding error introduced is 0.3% ($f_{\text{NOTCH}} = 59.8\text{Hz}$). Note that the natural frequency, f_o , is equal to f_{NOTCH} .

Figure 2 shows the response seen at the band reject or "Notch Out" node.

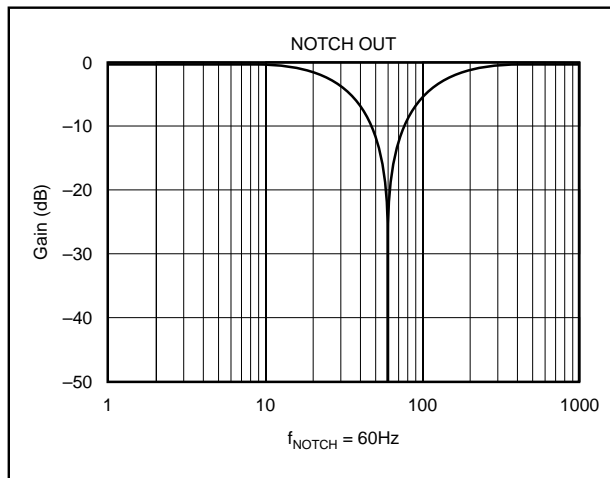

FIGURE 2. 60Hz Notch Response.

The highpass, bandpass and lowpass outputs yield the responses shown in Figure 3.

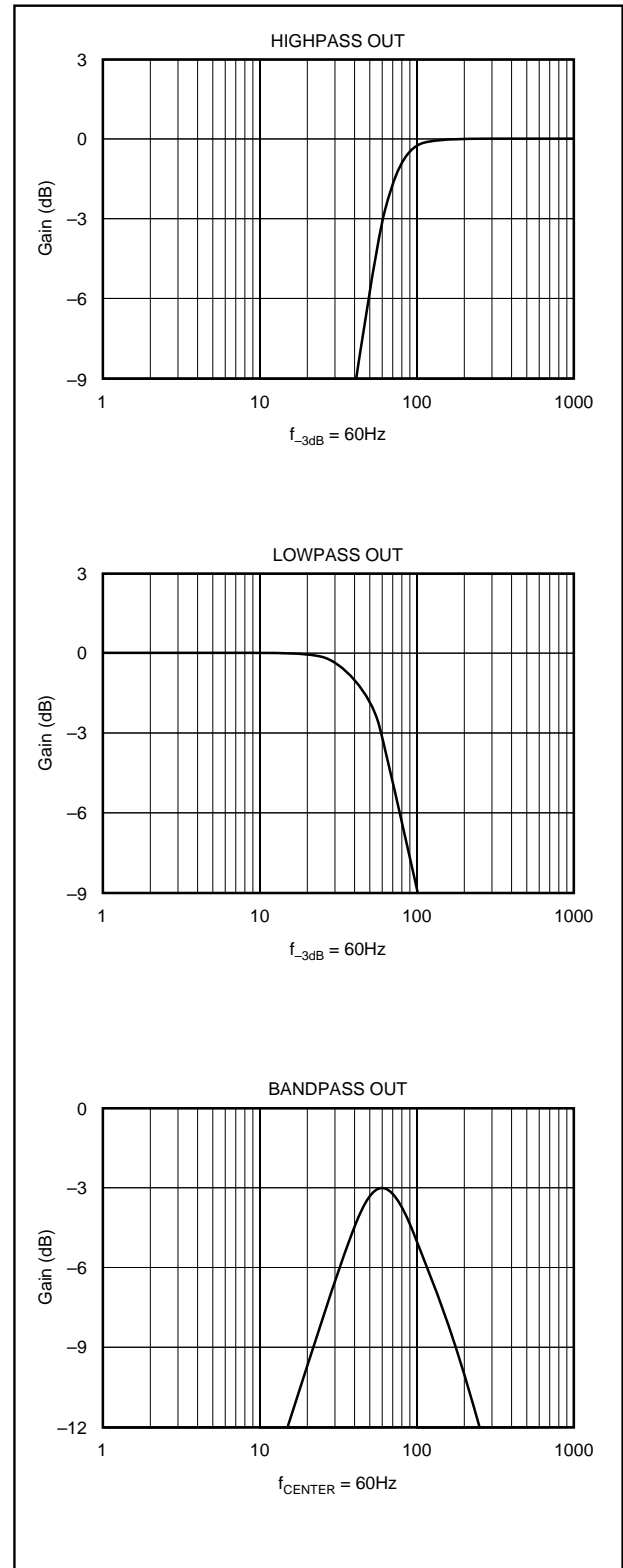

FIGURE 3. Highpass, Lowpass and Bandpass $f_o = 60\text{Hz}$ Response.

The filter in Figure 1 is set for a Q of 0.707. This can be adjusted using Equation 2 where,

$$R_Q = 50k\Omega \cdot Q \quad (2)$$

Setting the filter to a Q of 0.707 produces second-order Butterworth responses. The Q is not affected by the natural frequency programmed by the DACs. Note that for Butterworth filters, the natural frequency is also the -3dB (half power point) for lowpass and highpass responses. It also is the center frequency for bandpass filters and the notch frequency for band reject responses. The passband gain is unity for all response types except the bandpass. For the bandpass output, the gain at f_{CENTER} is equal to the filter Q.

LIMITATIONS

The maximum f_o in Figure 1 is set for 12.25kHz. This can be adjusted using Equation 1. Set the DAC gain term equal to $(2^n - 1)/2^n$, f_o = desired maximum natural frequency and solve for RF.

For example, to extend the maximum f_o to 20kHz,

$$RF = \frac{4095}{2 \cdot \pi \cdot 10^{-9} \cdot 20kHz} = 7.96k\Omega$$

The maximum natural frequency obtainable for the UAF42 is 100kHz.

f_o accuracy can decrease as the DAC gain decreases in an attempt to program low natural frequencies. For example, for a 12-bit DAC and maximum f_o set to 20kHz, the resolution giving one LSB change is,

$$\text{Resolution} = \frac{1}{2^{12}} \cdot f_{O_{MAX}} = \frac{1}{4096} \cdot 20kHz = 4.9Hz$$

When trying to program low natural frequencies like 12Hz, the digital word to the DAC would be 2.

So,

$$f_o = \frac{2}{4096} \cdot f_{O_{MAX}} = \frac{2}{4096} \cdot 20kHz = 9.8Hz$$

This is an 18% error. Resolution can be increased by reducing $f_{O_{MAX}}$ or using a higher order DAC. RF resistor tolerance should be kept below 1% to maintain f_o error to within $\pm 1\%$.

The OPA627 op amps are chosen for their low offset voltage, low noise, low input bias current (FET input), and high unity gain bandwidth (GBW = 16MHz) to maintain stability.