

THE ACF2101 USED AS A BIPOLAR SWITCHED INTEGRATOR

By Bonnie Baker

The ACF2101 is a dual, switched integrator that is typically used to convert a positive input current to a negative output voltage by integration, using an integration capacitor (C_{INT}), either on the chip or an external capacitor provided by the user. Typical applications for the ACF2101 are photo diode integrators (as shown in Figure 1), current measurements, charge measurements, and a CT scanner front end. In Figure 1, 1/2 of the ACF2101 integrates a positive input current to a 0 to -10V output signal. The transfer function of the integrator is:

$$V_{OUT} = -\frac{1}{C_{INT}} \int_0^t I_{IN} dt + \text{constant}$$

where C_{INT} = integration capacitor
 I_{IN} = positive input current
 constant = initial voltage at output

Assuming that the initial voltage at the output of the integrator is 0V, the transfer function becomes:

$$V_{OUT} = -\frac{1}{C_{INT}} \int_0^t I_{IN} dt$$

The ACF2101 is specified for a maximum input current of 100µA. The input current magnitude is limited by the slew rate of the operational amplifier and by the resistance of the

hold switch. The slew rate is specified at 1V/µs minimum. If the user has an input device that supplies a higher maximum positive current, an external capacitor can be added to comply with the slew rate specification of the operational amplifier and the input signal can be connected to the "In" pin, bypassing the hold switch.

The hold and reset switches are used to control the ACF2101. Three basic modes of operation are controlled by these switches. In the integrate mode, the output voltage integrates from 0 to -10V. In the hold mode, the output voltage is held at the present level. In the reset mode, the output returns to zero so the integration cycle can start again. The switching diagram for these modes are shown in Figure 2. The output of the ACF2101 is selectable by use of the select switches, which can be used to multiplex the outputs when multiple integrators are connected to a common bus. The internal capacitor (C_F) can be used alone or in parallel with an external capacitor (C_{OPT}). In addition, the external capacitor can be used without the internal capacitor if needed.

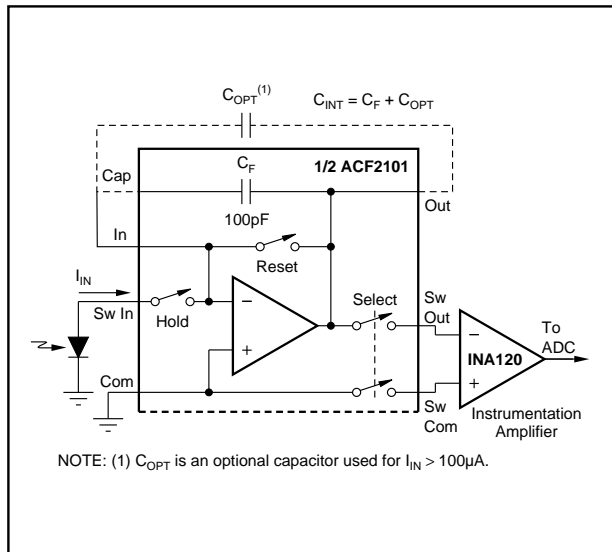

FIGURE 1. A Typical Application for the ACF2101 Switched Integrator.

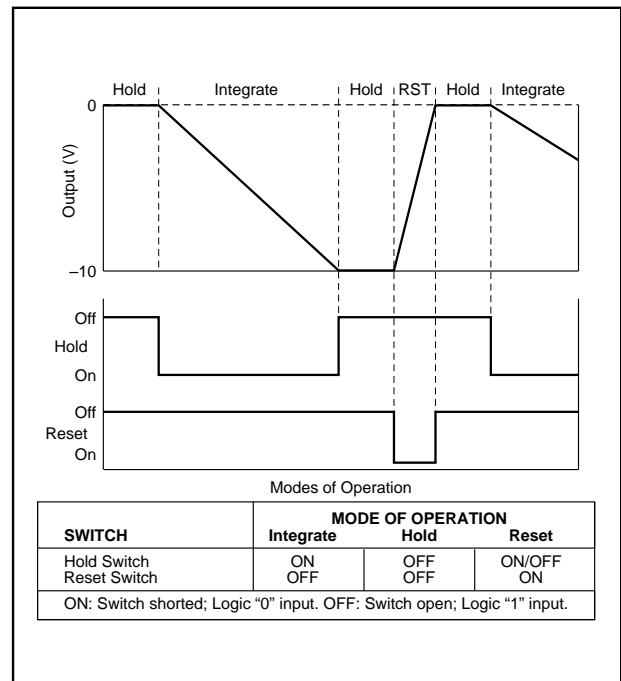

FIGURE 2. Modes of Operation for the ACF2101.

A second application for the ACF2101 is shown in Figure 3. Here the input current is bipolar such as found in radar or accelerometer applications. The hold and reset switches are designed to withstand $-10V$ to $+0.5V$. A bipolar input signal will cause the protection circuitry of the reset and hold switch to conduct if the input or output exceeds $+0.5V$. A positive dc offset current (I_{OFF}) is injected into the input of the integrator to balance the effects of the bipolar signal. The magnitude of the offset current (I_{OFF}) must be equal to or greater than the magnitude of the negative portion of the bipolar input current.

As an example, if the full scale input current of the input device is $\pm 25\mu A$, an offset current of $+25\mu A$ is required to insure the output will integrate negative. C_{OPT} is 50pf to take advantage of slew rate minimum of the ACF2101. With a $10\mu s$ integration time, the output of the ACF2101 will always be between $0V$ and $-10V$. A zero input current will

produce a $-5V$ output at the end of conversion. Output voltage vs bipolar input current is tabulated in Figure 3. C_1 clamps the input of the hold switch to less than $+0.5V$. As another example, the input current could be $\pm 1\mu A$. R_1 would be changed to $10M\Omega$ and C_{OPT} is no longer needed. With an integration time of 1ms, the output of the ACF2101 will always be between $0V$ and $-10V$.

In low current applications, errors are dominated by noise and offset error in the REF102, the input bias current of the operational amplifier in the ACF2101, and the tolerance error of C_F .

The ACF2101 dual integrator was intended to operate in a unipolar mode and features low noise of $10\mu V_{rms}$, low $100fA$ bias current and a wide 120dB dynamic range. With the addition of a REF102 and a resistor, the device can also be operated in a bipolar mode.

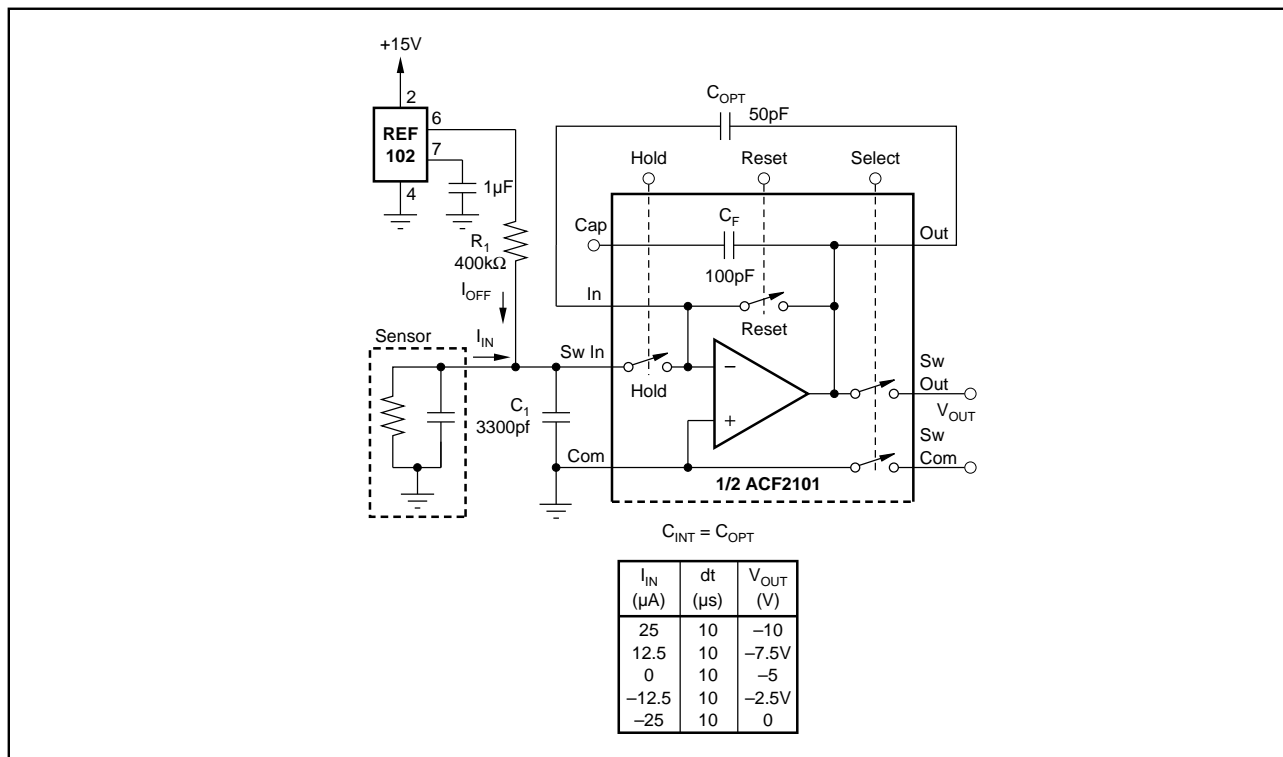

FIGURE 3. Using the ACF2101 with a Current Offset on the Input to Allow Bipolar Operation.