

VOLTAGE-REFERENCE FILTERS

By R. Mark Stitt (602) 746-7445

IMPROVED VOLTAGE-REFERENCE FILTER HAS SEVERAL ADVANTAGES

- LOW OUTPUT IMPEDANCE AT HIGH FREQUENCY FOR DRIVING DYNAMIC LOADS SUCH AS HIGH-SPEED A/D CONVERTERS
- IMPROVED NOISE FILTERING
- BETTER ACCURACY BY ELIMINATING CAPACITOR LEAKAGE ERRORS
- DRIVES LARGE CAPACITIVE LOADS

The Burr-Brown REF102 is a buried-zener-based precision 10.0V reference. It has better stability and about five times lower output noise than band-gap-based voltage references such as the PMI REF-10. Still, its output noise is about 600 μ Vp-p at a noise bandwidth of 1MHz (the output noise of the PMI REF-10 is about 3,000 μ Vp-p at 1MHz).

So far as we know, the stability with time of the REF102 is significantly better than any other single-chip voltage reference on the market. We plan more characterization of stability vs time, but it will probably not be available this year. The following preliminary data is all we have for now. The devices used were off-the-shelf. They were not burned-in, or otherwise stabilized prior to this stability test.

Noise of a voltage reference can be reduced by filtering its output. Broadband noise can be reduced by the square-root of the reduction in noise bandwidth. Filtering the output of the reference to reduce the noise bandwidth by 100/1 (from 1MHz to 10kHz, for example) can reduce the noise by 10/1 (from 600 μ Vp-p to 60 μ Vp-p).

The conventional circuit, shown in Figure 1, uses a single-pole RC filter and a buffer amplifier. One problem with this circuit is that leakage current through the filter capacitor, C_1 , flows through R_1 resulting in DC error. Furthermore, changes in leakage with temperature result in drift. The relatively low RC time constants often needed dictate large capacitor values prone to this problem.

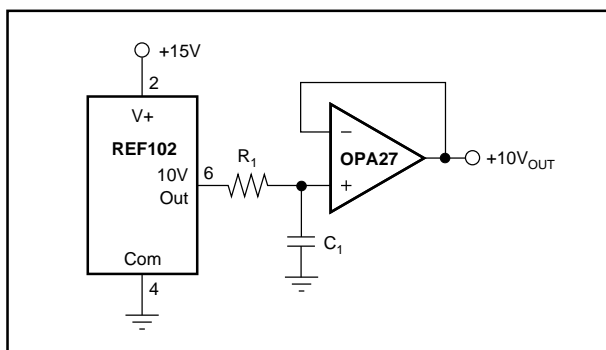

FIGURE 1. Voltage Reference with Conventional Filter.

REF102CM +10.0V REFERENCE STABILITY vs TIME

$T_A = 25^\circ\text{C}$, $V_S = +15\text{V}$.

UNIT	V_{OUT} CHANGE FROM 1 HR TO 168 HRS [ppm]	V_{OUT} CHANGE FROM 1 HR TO 1008 HRS [ppm]	V_{OUT} CHANGE FROM 1 HR TO 2016 HRS [ppm]	V_{OUT} CHANGE FROM 1 HR TO 3072 HRS [ppm]	V_{OUT} CHANGE FROM 1 HR TO 5136 HRS [ppm]	V_{OUT} CHANGE FROM 1 HR TO 14205 HRS [ppm]
1	6.8	5.5	7.1	4.7	8.2	11.7
2	5.1	1.0	1.2	-2.1	0.1	1.3
3	9.4	6.5	3.2	1.0	1.8	2.0
4	9.6	6.9	7.7	5.6	7.6	10.3
5	12.9	7.8	9.6	6.7	9.5	12.8
6	10.5	6.4	5.3	3.0	5.4	9.4
7	10.3	5.7	6.2	3.7	5.8	8.2
8	17.0	14.5	12.9	9.2	9.9	13.7
9	6.2	5.1	3.8	1.7	2.7	4.1
10	7.1	1.7	1.3	0.1	1.0	2.4
11	13.0	9.6	9.6	10.0	13.0	16.5
12	7.5	4.7	3.9	4.2	5.0	7.4
13	13.0	9.5	10.4	8.2	9.9	13.7
14	4.2	3.0	0.5	-0.3	4.2	2.8
15	7.3	4.3	2.6	1.8	4.1	3.9

Another problem with the conventional filter is the added noise of the buffer amplifier. The noise of the buffer amplifier acts at the buffer's full unity-gain bandwidth adding to the output noise of the circuit. Even if the noise at the output of the RC filter is zero, the noise added by the buffer can be intolerable in many applications. The improved filter, shown in Figure 2, solves both problems.

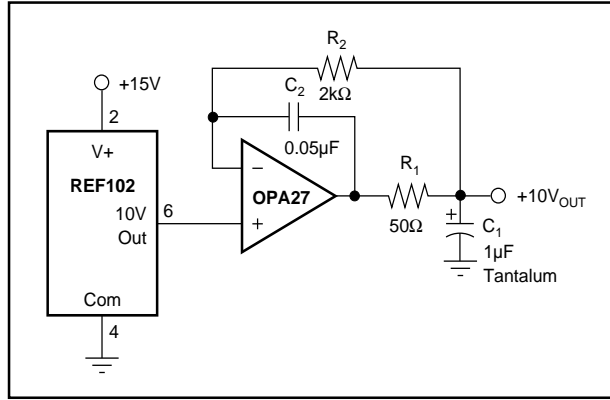

FIGURE 2. Voltage Reference with Improved Filter.

The improved filter places the RC filter at the output of the buffer amplifier. Reference noise is filtered by a single pole of $f_{-3dB} = 2 \cdot \pi \cdot R_1 \cdot C_1$. The R_2, C_2 network assures amplifier loop stability. Set $R_2 \cdot C_2 = 2 \cdot R_1 \cdot C_1$ to minimize amplifier noise gain peaking. Since buffer amplifier bias current flows through R_2 , keep the value of R_2 low enough to minimize both DC error and noise due to op amp bias-current noise. Also, load current flows in R_1 . The resulting voltage drop adds to the required swing at the output of the buffer amplifier. Keep the voltage drop across R_1 low, e.g. less than 1V at full load, to prevent the amplifier output from saturating by swinging too close to its power-supply rail.

With the RC filter at the output of the buffer, the noise of both the voltage reference and the buffer is filtered. Since the filter is in the feedback loop of the buffer amplifier, C_1 leakage current errors reacting with R_1 are divided down to an insignificant level by the loop gain of the buffer amp. The feedback also keeps the DC output impedance of the improved filter near zero. Also, leakage through C_2 is negligible since the voltage across it is nearly zero.

At high frequency, the output impedance of the improved filter is low due to C_1 . The reactance of a 1μF capacitor is 0.16Ω at 1MHz. For an A/D converter reference, connect C_1 as close to the reference input pin as possible.

The improved filter can drive large capacitive loads without stability problems. Just keep $(C_{LOAD} + C_1) \cdot R_1 < 0.5 \cdot R_2 \cdot C_2$.

There is one caution with the improved filter. Although the output impedance is low at both high frequencies and DC, it peaks at midband frequencies. Reduced loop gain due to the R_2, C_2 network is responsible. A peak output impedance of about $0.7 \cdot R_1$ occurs near the filter pole frequency. If lower midband output impedance is required, R_1 must be reduced and C_1 increased accordingly.

The information provided herein is believed to be reliable; however, BURR-BROWN assumes no responsibility for inaccuracies or omissions. BURR-BROWN assumes no responsibility for the use of this information, and all use of such information shall be entirely at the user's own risk. Prices and specifications are subject to change without notice. No patent rights or licenses to any of the circuits described herein are implied or granted to any third party. BURR-BROWN does not authorize or warrant any BURR-BROWN product for use in life support devices and/or systems.