

PGA206
PGA207

High-Speed Programmable Gain INSTRUMENTATION AMPLIFIER

FEATURES

- **DIGITALLY PROGRAMMABLE GAINS:**
PGA206: $G=1, 2, 4, 8V/V$
PGA207: $G=1, 2, 5, 10V/V$
- **TRUE INSTRUMENTATION AMP INPUT**
- **FAST SETTLING: 3.5 μ s to 0.01%**
- **FET INPUT: $I_B = 100pA$ max**
- **INPUT PROTECTION: $\pm 40V$**
- **LOW OFFSET VOLTAGE: 1.5mV max**
- **16-PIN DIP, SOL-16 SOIC PACKAGES**

APPLICATIONS

- **MULTIPLE-CHANNEL DATA ACQUISITION**
- **MEDICAL, PHYSIOLOGICAL AMPLIFIER**
- **PC-CONTROLLED ANALOG INPUT BOARDS**

DESCRIPTION

The PGA206 and PGA207 are digitally programmable gain instrumentation amplifiers that are ideally suited for data acquisition systems.

The PGA206 and PGA207's fast settling time allows multiplexed input channels for excellent system efficiency. FET inputs eliminate I_B errors due to analog multiplexer series resistance.

Gains are selected by two CMOS/TTL-compatible address lines. Analog inputs are internally protected for overloads up to $\pm 40V$, even with the power supplies off. The PGA206 and PGA207 are laser-trimmed for low offset voltage and low drift.

The PGA206 and PGA207 are available in 16-pin plastic DIP and SOL-16 surface-mount packages. Both are specified for $-40^{\circ}C$ to $+85^{\circ}C$ operation.

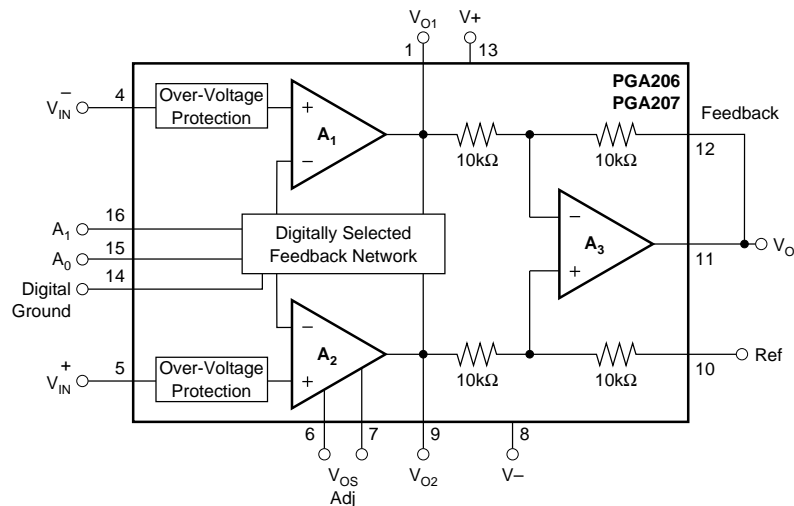

International Airport Industrial Park • Mailing Address: PO Box 11400 • Tucson, AZ 85734 • Street Address: 6730 S. Tucson Blvd. • Tucson, AZ 85706
Tel: (520) 746-1111 • Twx: 910-952-1111 • Cable: BBRCORP • Telex: 066-6491 • FAX: (520) 889-1510 • Immediate Product Info: (800) 548-6132

SPECIFICATIONS

At $T_A = +25^\circ\text{C}$, $V_S = \pm 15\text{V}$, $R_L = 2\text{k}\Omega$ unless otherwise noted.

PARAMETER	CONDITIONS	PGA206P, U PGA207P, U			PGA206PA, UA PGA207PA, UA			UNITS
		MIN	TYP	MAX	MIN	TYP	MAX	
INPUT								
Offset Voltage, RTI Initial	All Gains $T_A = +25^\circ\text{C}$		± 0.5	± 1.5		± 1	± 2.5	mV
vs Temperature	$T_A = T_{\text{MIN}}$ to T_{MAX} , $G = 8, 10$		± 2			*		$\mu\text{V}/^\circ\text{C}$
vs Power Supply	$V_S = \pm 4.5\text{V}$ to $\pm 18\text{V}$		± 5	± 20		± 10	± 40	$\mu\text{V}/\text{V}$
Long-Term Stability			4.5			*		$\mu\text{V}/\text{mo}$
Impedance, Differential			$10^{13} \parallel 1$			*		$\Omega \parallel \text{pF}$
Common-Mode			$10^{12} \parallel 4$			*		$\Omega \parallel \text{pF}$
Common-Mode Voltage Range ⁽¹⁾	$V_O = 0\text{V}$	$\pm(V_S -4)$	$\pm(V_S -2.5)$		*	*		V
Safe Input Voltage				± 40			*	V
Common-Mode Rejection	$V_{\text{CM}} = \pm 11\text{V}$, $\Delta R_S = 1\text{k}\Omega$							
	$G = 1$	80	92		75	86		dB
	$G = 2$	85	96		80	90		dB
	$G = 4$ or 5	90	100		84	94		dB
	$G = 8$ or 10	95	100		84	94		dB
INPUT BIAS CURRENT	$V_{\text{IN}} = 0$		2	100		*	*	pA
vs Temperature			See Typical Curve			*		
Offset Current			1	100		*	*	pA
vs Temperature			See Typical Curve			*		
NOISE VOLTAGE, RTI	$G = 8, 10$; $R_S = 0\Omega$							
$f = 10\text{Hz}$			30			*		$\text{nV}/\sqrt{\text{Hz}}$
$f = 100\text{Hz}$			20			*		$\text{nV}/\sqrt{\text{Hz}}$
$f = 1\text{kHz}$			18			*		$\text{nV}/\sqrt{\text{Hz}}$
$f_B = 0.1\text{Hz}$ to 10Hz			1			*		$\mu\text{Vp-p}$
Noise Current								
$f = 1\text{kHz}$			1.5			*		$\text{fA}/\sqrt{\text{Hz}}$
GAIN	All Gains, $V_O = \pm 11\text{V}$							
Gain Error			± 0.01	± 0.05		*	± 0.1	%
Gain vs Temperature ⁽²⁾			± 1	± 10		*	*	$\text{ppm}/^\circ\text{C}$
Nonlinearity			± 0.0003	± 0.002		*	± 0.005	% of FSR
OUTPUT								
Voltage, Positive		(V+) -4	(V+) -2.3		*	*		V
Negative		(V-) +4	(V-) +1.5		*	*		V
Load Capacitance Stability			1000			*		pF
Short-Circuit Current			± 17			*		mA
FREQUENCY RESPONSE								
Bandwidth, -3dB	$G = 1$		5			*		MHz
	$G = 2$		4			*		MHz
	$G = 4, 5$		1.3			*		MHz
	$G = 8, 10$		600			*		kHz
Slew Rate	$V_O = \pm 10\text{V}$, $G = 1$ to 10		25			*		$\text{V}/\mu\text{s}$
Settling Time, 0.1%	20V Step, All Gains		2			*		μs
0.01%	20V Step, All Gains		3.5			*		μs
Output Overload Recovery	50% Overdrive		1.5			*		μs
DIGITAL LOGIC INPUTS								
Digital Ground Voltage, V_{DG}		V-		(V+) -4	*		*	V
Digital Low Voltage		V-		$V_{\text{DG}} + 0.8\text{V}$	*		*	V
Digital Input Current			1			*		pA
Digital High Voltage		$V_{\text{DG}} + 2$		V+	*		*	V
Gain Switching Time			500			*		ns
POWER SUPPLY								
Voltage Range		± 4.5	± 15	± 18	*	*	*	V
Current	$V_{\text{IN}} = 0\text{V}$		$+12.4/-11.2$	± 13.5		*		mA
TEMPERATURE RANGE								
Specification		-40		+85	*		*	$^\circ\text{C}$
Operating		-40		+125	*		*	$^\circ\text{C}$
Thermal Resistance, θ_{JA}			80			*		$^\circ\text{C}/\text{W}$

* Specification same as PGA206P or PGA207P.

NOTES: (1) Input common-mode range varies with output voltage—see typical curves. (2) Guaranteed by wafer test.

The information provided herein is believed to be reliable; however, BURR-BROWN assumes no responsibility for inaccuracies or omissions. BURR-BROWN assumes no responsibility for the use of this information, and all use of such information shall be entirely at the user's own risk. Prices and specifications are subject to change without notice. No patent rights or licenses to any of the circuits described herein are implied or granted to any third party. BURR-BROWN does not authorize or warrant any BURR-BROWN product for use in life support devices and/or systems.

DICE INFORMATION

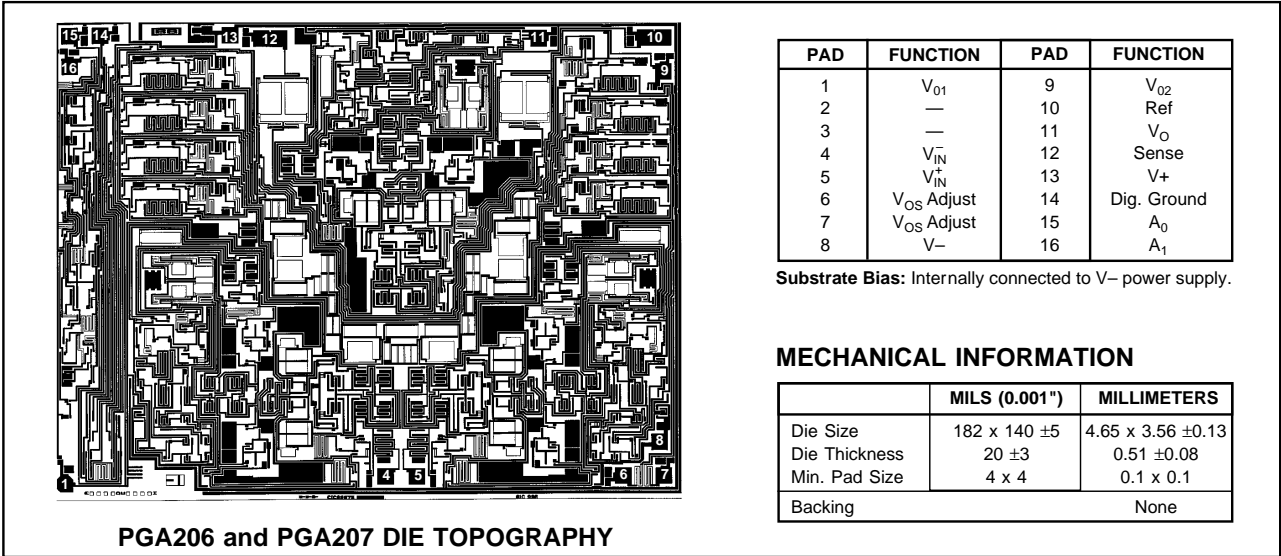

PIN CONFIGURATION

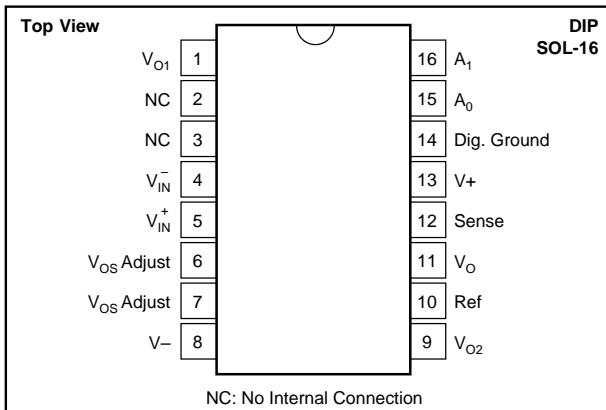

ABSOLUTE MAXIMUM RATINGS

Supply Voltage	±18V
Analog Input Voltage Range	±40V
Logic Input Voltage Range	± V_S
Output Short-Circuit (to ground)	Continuous
Operating Temperature	-40°C to +125°C
Storage Temperature	-40°C to +125°C
Junction Temperature	+150°C
Lead Temperature (soldering -10s)	+300°C

PACKAGE INFORMATION

MODEL	PACKAGE	PACKAGE DRAWING NUMBER ⁽¹⁾
PGA206PA	16-Pin Plastic DIP	180
PGA206P	16-Pin Plastic DIP	180
PGA206UA	SOL-16 Surface Mount	211
PGA206U	SOL-16 Surface Mount	211
PGA207PA	16-Pin Plastic DIP	180
PGA207P	16-Pin Plastic DIP	180
PGA207UA	SOL-16 Surface Mount	211
PGA207U	SOL-16 Surface Mount	211

NOTE: (1) For detailed drawing and dimension table, please see end of data sheet, or Appendix D of Burr-Brown IC Data Book.

ORDERING INFORMATION

MODEL	GAINS	PACKAGE	TEMPERATURE RANGE
PGA206PA	1, 2, 4, 8V/V	16-Pin Plastic DIP	-40°C to +85°C
PGA206P	1, 2, 4, 8V/V	16-Pin Plastic DIP	-40°C to +85°C
PGA206UA	1, 2, 4, 8V/V	SOL-16 Surface-Mount	-40°C to +85°C
PGA206U	1, 2, 4, 8V/V	SOL-16 Surface-Mount	-40°C to +85°C
PGA207PA	1, 2, 5, 10V/V	16-Pin Plastic DIP	-40°C to +85°C
PGA207P	1, 2, 5, 10V/V	16-Pin Plastic DIP	-40°C to +85°C
PGA207UA	1, 2, 5, 10V/V	SOL-16 Surface-Mount	-40°C to +85°C
PGA207U	1, 2, 5, 10V/V	SOL-16 Surface-Mount	-40°C to +85°C

ELECTROSTATIC DISCHARGE SENSITIVITY

This integrated circuit can be damaged by ESD. Burr-Brown recommends that all integrated circuits be handled with appropriate precautions. Failure to observe proper handling and installation procedures can cause damage.

ESD damage can range from subtle performance degradation to complete device failure. Precision integrated circuits may be more susceptible to damage because very small parametric changes could cause the device not to meet its published specifications.

TYPICAL PERFORMANCE CURVES

At $T_A = +25^\circ\text{C}$, and $V_S = \pm 15\text{V}$, unless otherwise noted.

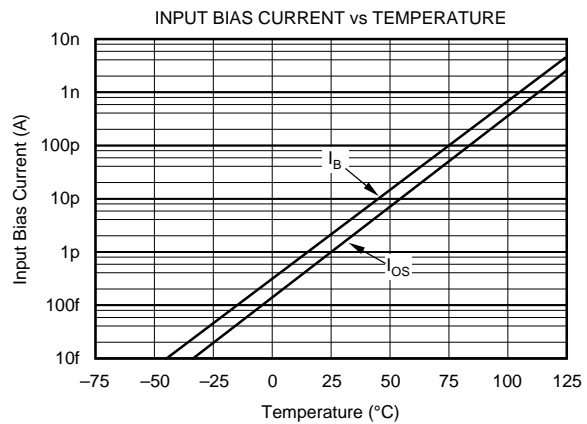
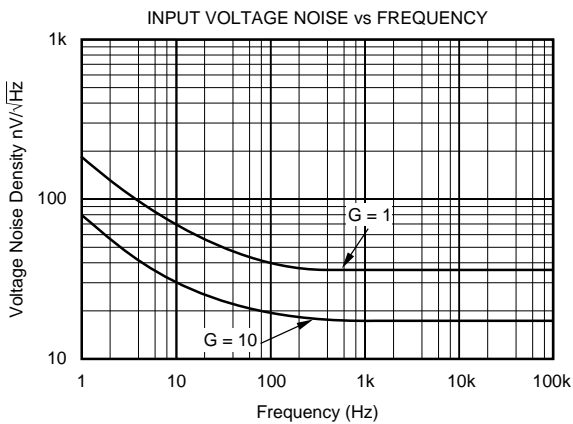
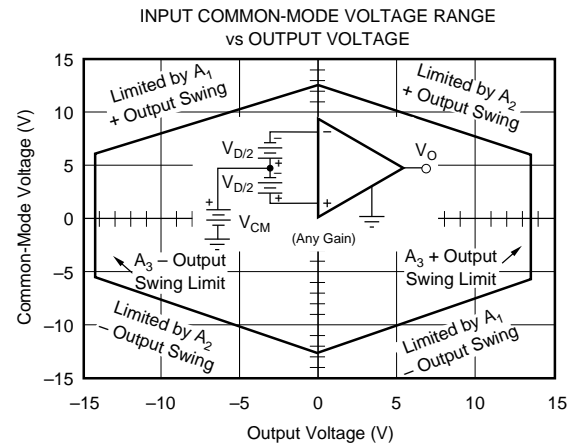
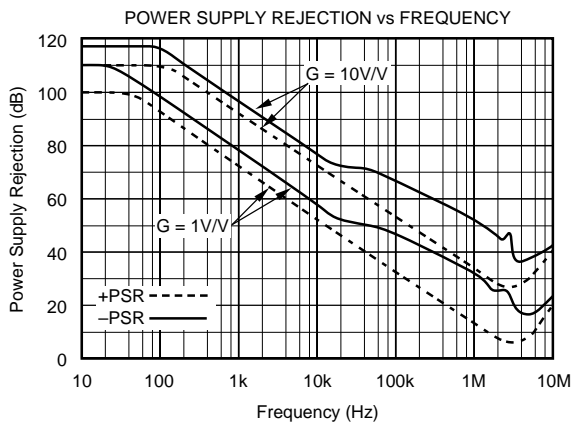
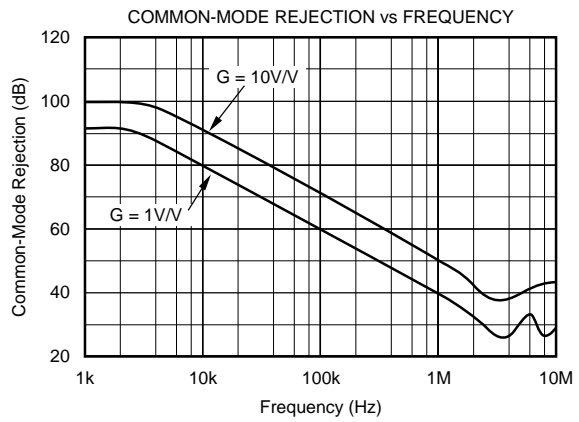
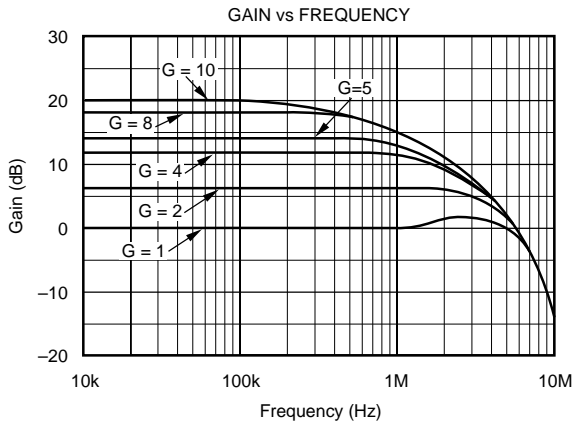

TYPICAL PERFORMANCE CURVES (CONT)

At $T_A = +25^\circ\text{C}$, and $V_S = \pm 15\text{V}$, unless otherwise noted.

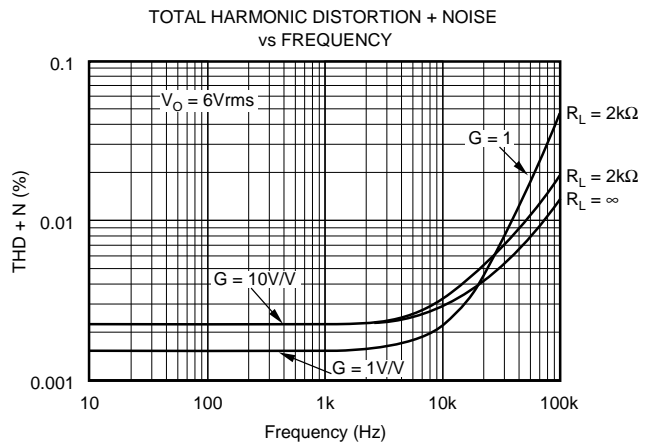
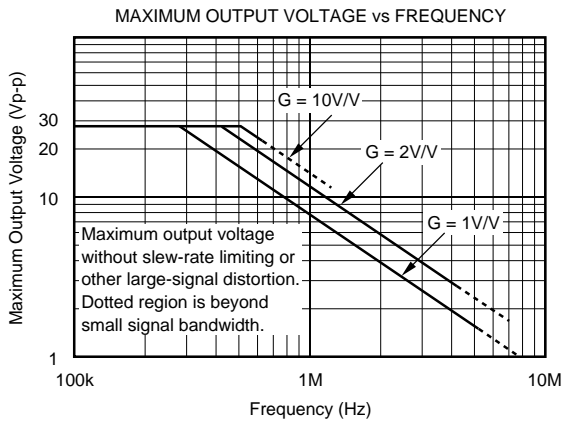
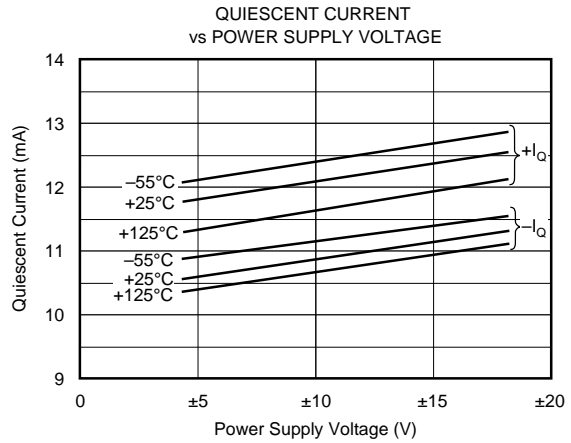
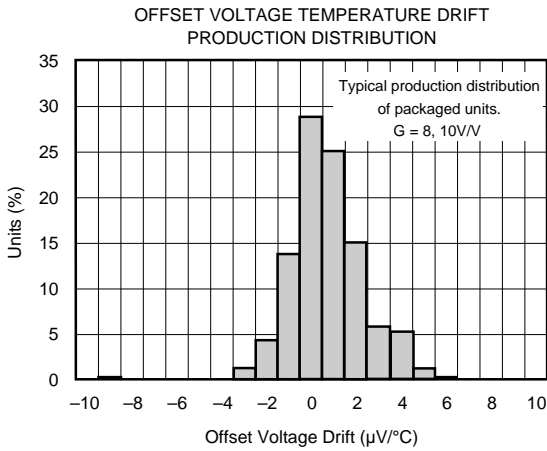
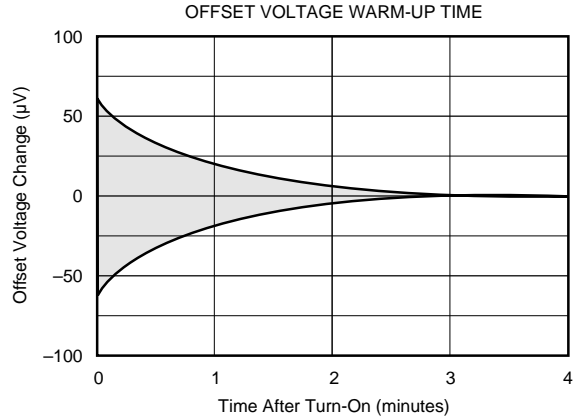
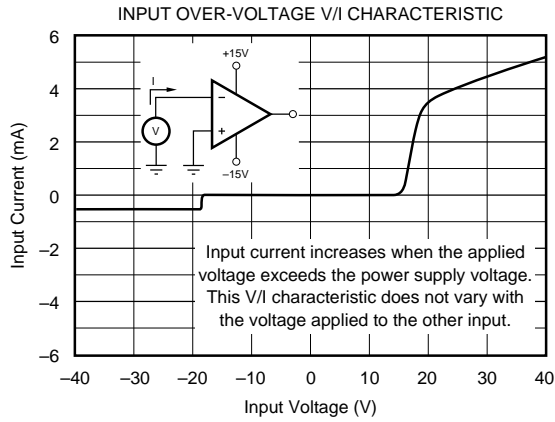

TYPICAL PERFORMANCE CURVES (CONT)

At $T_A = +25^\circ\text{C}$, and $V_S = \pm 15\text{V}$, unless otherwise noted.

SMALL SIGNAL RESPONSE
 $G = 1, C_L = 50\text{pF}$

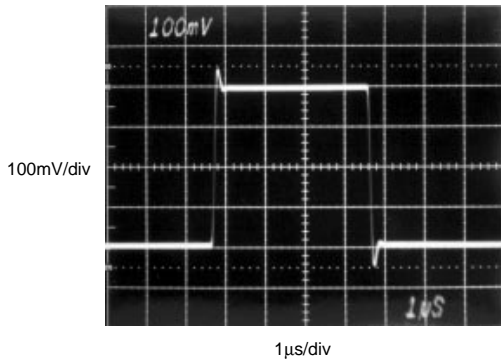

SMALL SIGNAL RESPONSE
 $G = 10, C_L = 50\text{pF}$

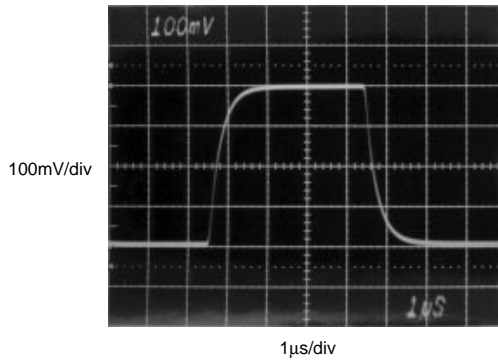

LARGE SIGNAL RESPONSE
 $G = 1, C_L = 50\text{pF}$

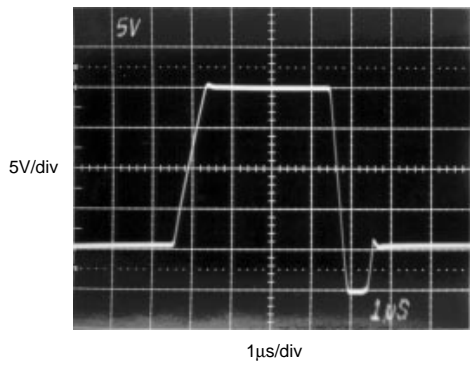

LARGE SIGNAL RESPONSE
 $G = 10, C_L = 50\text{pF}$

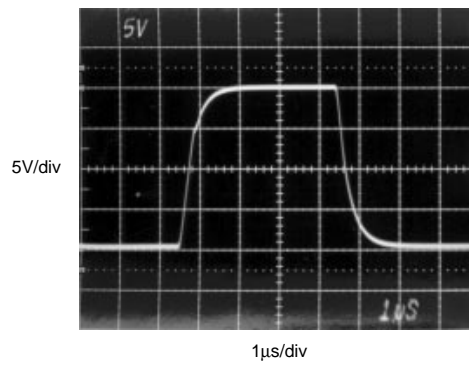

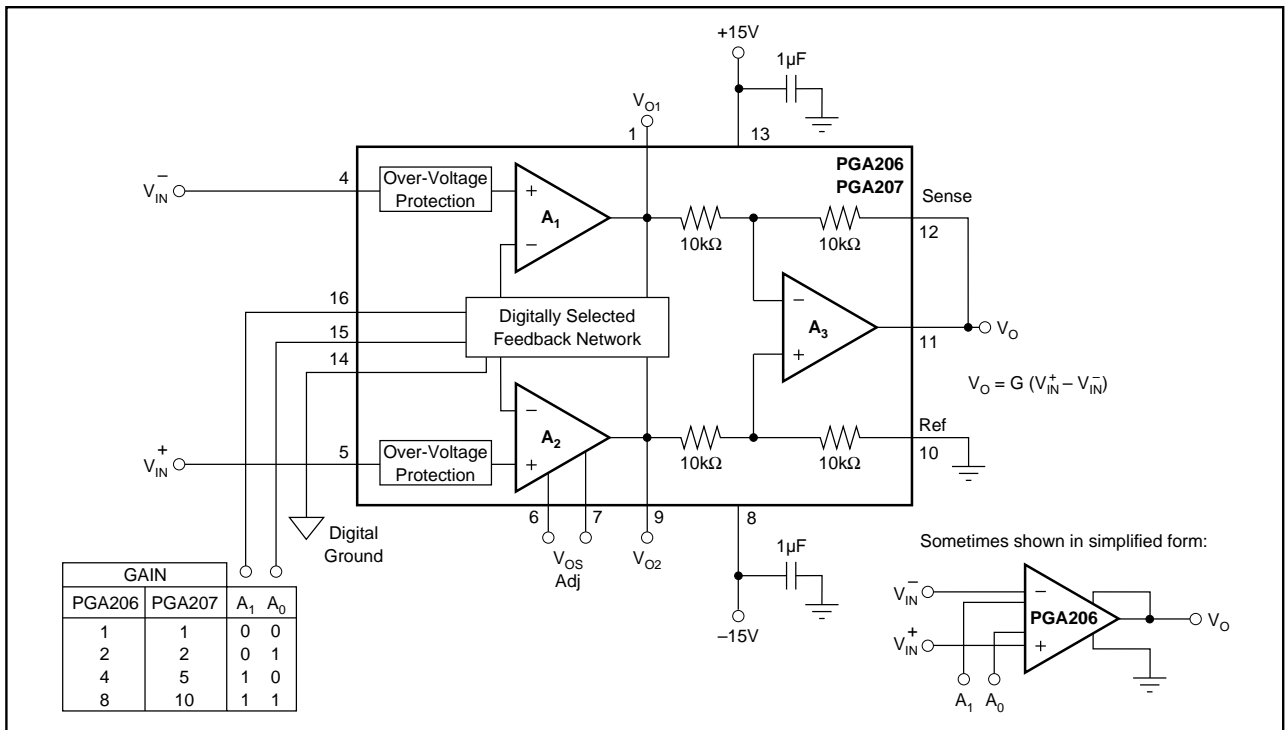

FIGURE 1. Basic Connections.

APPLICATIONS INFORMATION

Figure 1 shows the circuit diagram for basic operation of the PGA206 or PGA207. Applications with noisy or high impedance power supplies may require decoupling capacitors close to the device pins as shown.

The output is referred to the output reference (Ref) terminal which is normally grounded. This must be a low-impedance connection to assure good common-mode rejection. A resistance of 2Ω in series with the Ref pin will cause a typical device to degrade to approximately 80dB CMR ($G = 1$).

The output sense connection (pin 12) must be connected to the output terminal (pin 11) for proper operation. This connection can be made at the load for best accuracy.

DIGITAL INPUTS

The digital inputs A_0 and A_1 select the gain according to the logic table in Figure 1. Logic “1” is defined as a voltage greater than 2V above digital ground potential (pin 14). Digital ground can be connected to any potential ranging from the V_- power supply to 4V less than V_+ . Digital ground is usually equal to analog ground potential and the two grounds are connected at the power supply. The digital inputs interface directly to CMOS and TTL logic.

A nearly constant current of approximately 1.2mA flows in the digital ground pin. It is good practice to return digital ground through a separate connection path so that analog ground is not affected by the digital ground current.

The digital inputs, A_0 and A_1 , are not latched. A change in logic input immediately selects a new gain. Switching time of the logic is approximately 500ns. The time to respond to gain change is equal to switching time, plus the time it takes the amplifier to settle to a new output voltage in the newly selected gain (see settling time specifications).

Many applications use an external logic latch to acquire gain control data from a high speed digital bus. Using an external latch isolates the high speed digital bus from sensitive analog circuitry. Locate the digital latch as far as practical from analog circuitry to avoid coupling digital noise into analog input circuitry.

OFFSET VOLTAGE ADJUSTMENT

The PGA206 and PGA207 are laser trimmed for very low offset voltage and drift. Many applications require no external offset adjustment. Multiplexed data acquisition systems generally correct offset by grounding the inputs of one channel to measure offset voltage. Stored offset values for each gain are then subtracted from subsequent readings of other channels.

Figure 2 shows optional offset voltage trim circuits. Offset voltage changes with the selected gain. To adjust for low offset voltage in all gains, both input and output offsets must be trimmed.

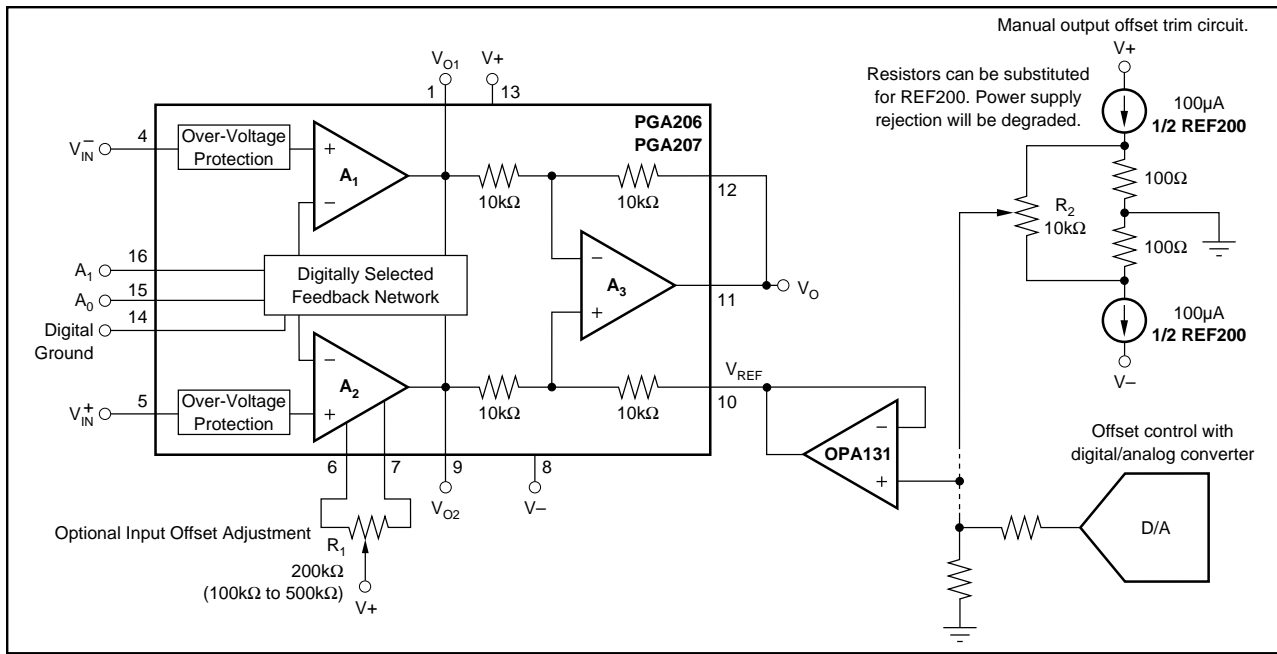

FIGURE 2. Optional Offset Voltage Trim Circuits.

R_1 adjusts the offset of the input amplifiers. Output stage offset is adjusted with R_2 . A buffer op amp is required in the output offset adjustment circuit, as shown, to assure that the Ref pin is driven by a low source impedance. To adjust for low offset voltage in all gains, first adjust the input stage offset in the highest gain. Then adjust the output stage offset (R_2) in $G = 1$. Iterate the adjustments for lowest offset in all gains.

Offset can also be adjusted under processor control with a D/A converter as shown in Figure 2. The D/A's output voltage can be reduced with a resistor divider for better adjustment resolution, but an op amp buffer following the divider is required to provide a low source impedance to the ref terminal. A different offset value is required for each amplifier gain.

INPUT BIAS CURRENT RETURN PATH

The FET inputs of the PGA206 and PGA207 provide extremely high input impedance. Still, a path must be provided for the bias current of each input. Figure 3 shows provisions for an input bias current path. Without a bias current return path, the inputs will float to a potential which exceeds the linear input voltage range and the input amplifiers will saturate.

If the differential source resistance is low, a bias current return path can be connected to only one input (see thermocouple example in Figure 3). With higher source impedance, using two resistors provides a balanced input with possible advantages of lower input offset voltage due to bias current and better common-mode rejection.

Many sources or sensors inherently provide a path for input bias current (e.g. the bridge sensor shown in Figure 3). These applications do not require additional resistor(s) for proper operation.

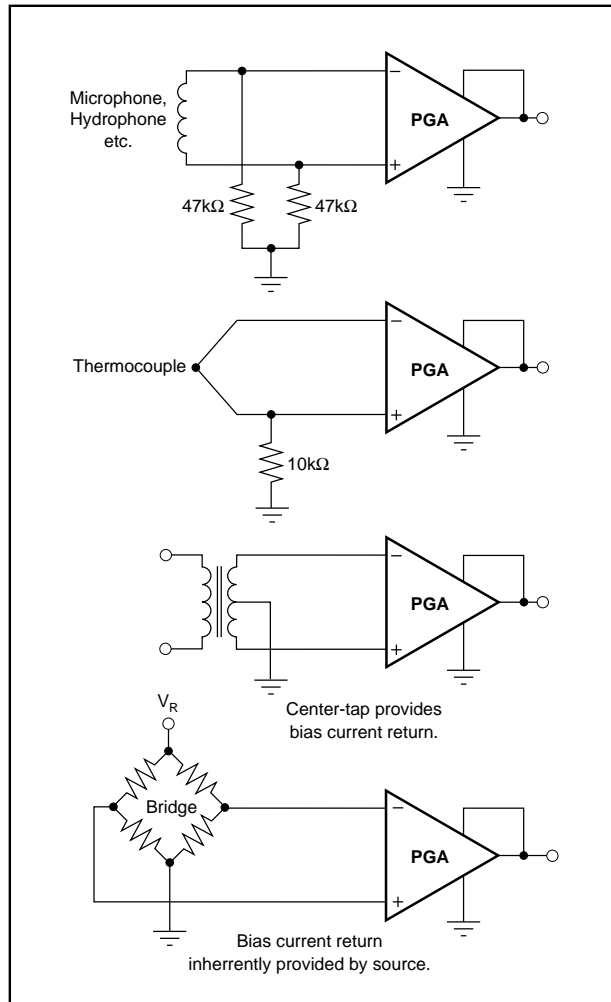

FIGURE 3. Providing an Input Bias Current Path.

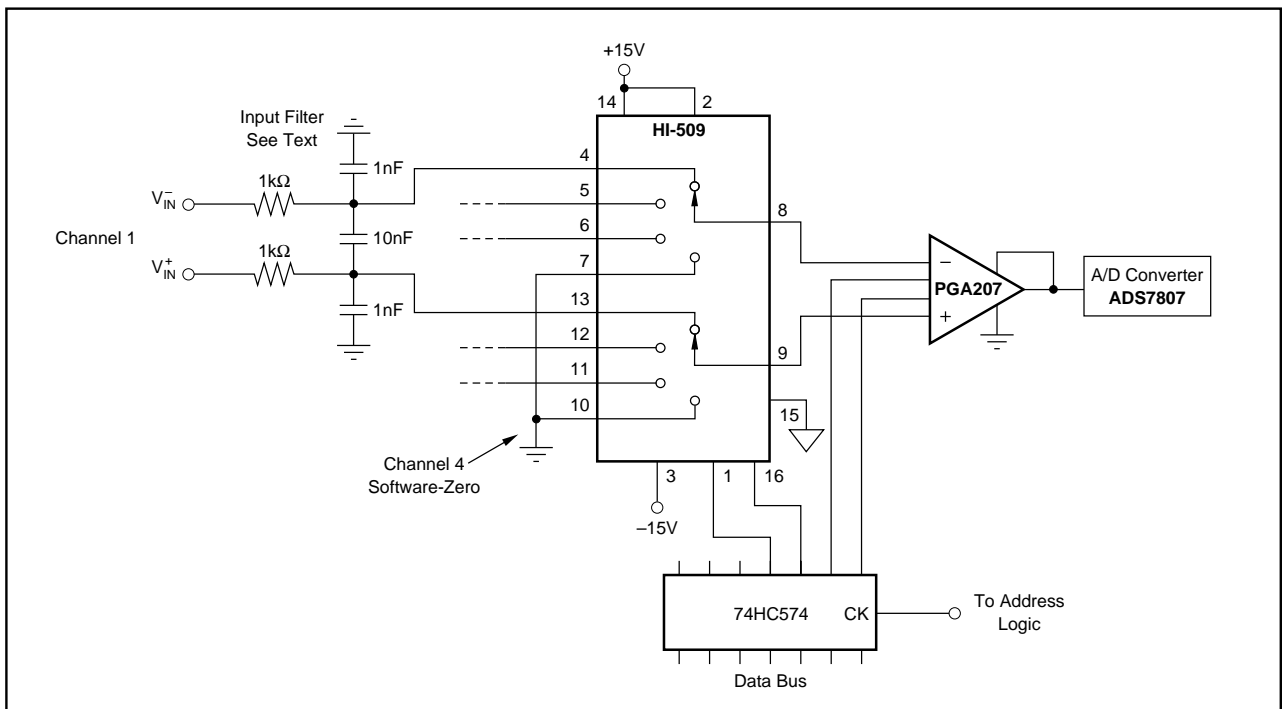

FIGURE 4. Multiplexed-Input Signal Acquisition System.

INPUT COMMON-MODE RANGE

The linear input voltage range of the PGA206 and PGA207 is from approximately 2.3V below the positive supply voltage to 1.5V above the negative supply. As a differential input voltage causes output voltage to increase, however, the linear input range is limited by the output voltage swing of amplifiers A_1 and A_2 . So the linear common-mode input range is related to the output voltage of the complete amplifier. This behavior also depends on supply voltage—see performance curves “Input Common-Mode Range vs Output Voltage”.

Input overload can produce an output voltage that appears normal. For example, if an input overload condition drives both input amplifiers to their positive output swing limit, the difference voltage measured by the output amplifier will be near zero. The output of the PGA206 or PGA207 will be near 0V even though both inputs are overloaded. This condition can be detected by sensing the voltage on the V_{O1} and V_{O2} pins to determine whether they are within their linear operating range.

INPUT PROTECTION

The inputs of the PGA206 and PGA207 are individually protected for voltages up to $\pm 40V$. For example, a condition of $-40V$ on one input and $+40V$ on the other input will not cause damage. Internal circuitry on each input provides low series impedance under normal signal conditions. If the input is overloaded, the protection circuitry limits the input current to a safe value. The typical performance curve “Input Overload V/I Characteristic” shows this behavior. The inputs are protected even if no power supply voltage is applied.

MULTIPLEXED INPUTS

The PGA206 and PGA207 are ideally suited for multiple channel data acquisition. Figure 4 shows a typical application with an analog multiplexer used to connect one of four differential input signals to a single PGA207.

Careful circuit layout will help preserve accuracy of multiplexed signals. Run the inverting and non-inverting connections of each channel parallel to each other over a ground plane, or directly adjacent on top and bottom of the circuit board. Grounded guard traces between channels help reduce stray signal pick-up.

Multiplexed signals from high impedance sources require special care. As inputs are switched by the multiplexer, charge can be injected into the source, disturbing the input signal. Since many such sources involve slow signals, a simple R/C filter at the input can be used to dramatically reduce this effect. The arrangement shown filters both the differential signal and common-mode noise.

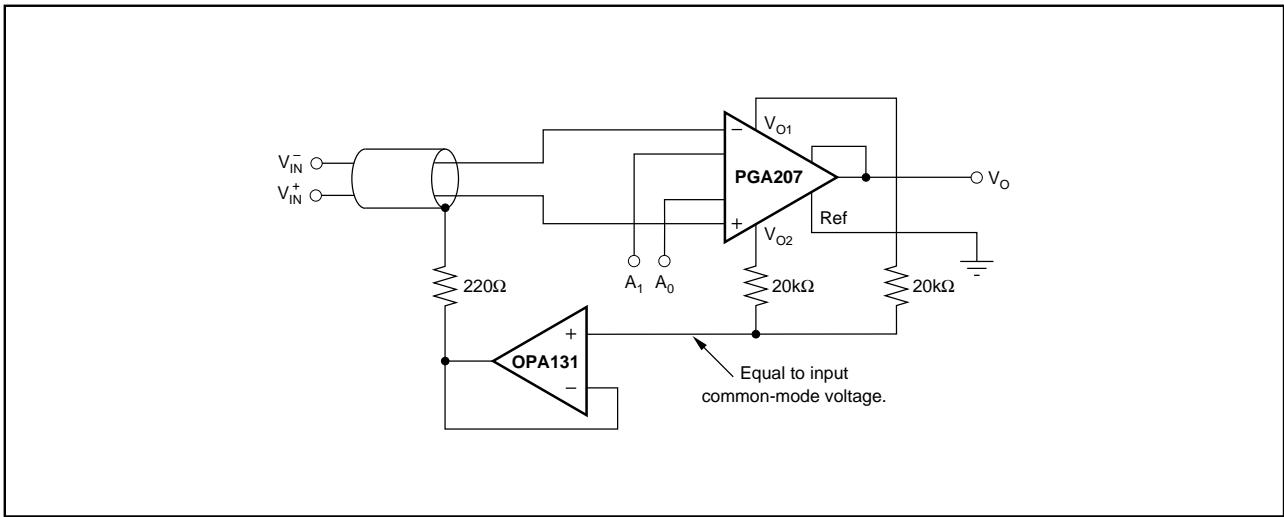

FIGURE 5. Shield Drive Circuit.

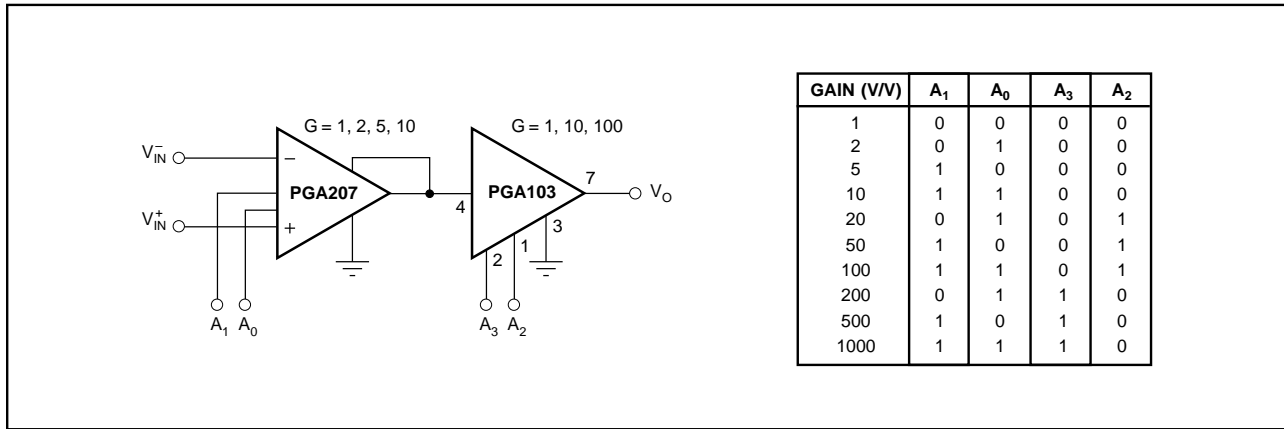

FIGURE 6. Wide Gain Range Programmable IA.