



# DRV1101

## HIGH POWER DIFFERENTIAL LINE DRIVER

### FEATURES

- HIGH OUTPUT CURRENT: 230mA
- SINGLE SUPPLY OPERATION: 5V
- 10MHz BANDWIDTH: 6Vp-p into 15Ω
- VERY LOW THD AT HIGH POWER: -81dBc at 6Vp-p, 100kHz, 100Ω
- FIXED DIFFERENTIAL GAIN: 3V/V

### APPLICATIONS

- DSL TWISTED PAIR LINE DRIVER
- COMMUNICATIONS LINE DRIVER
- TWISTED-PAIR CABLE DRIVER

### DESCRIPTION

The DRV1101 is fixed gain differential line driver designed for very low distortion operation when driving DSL line transformers. It is designed for use as the upstream line driver for ADSL G.Lite, and as both upstream and downstream line drivers in CAP systems. Operating on a single 5V supply, the DRV1101 can supply up to 230mA peak output current. The output voltage can swing up to 9.5Vp-p on a single 5V supply. In ADSL G.Lite applications, DRV1101 can supply up to 10dBm average *line* power with a crest factor of 5.3 for a peak line power delivered of approximately 25dBm. It is packaged in a 8-lead SOIC.

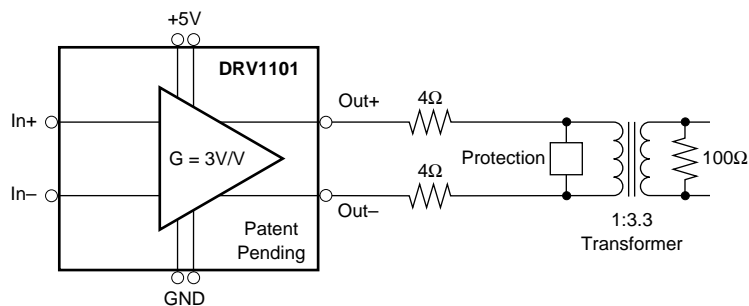

# SPECIFICATIONS

Typical at 25°C,  $V_{CM} = V_{DD}/2$ ,  $V_{DD} = +5.0V$ , unless otherwise specified.

PARAMETER	CONDITIONS	DRV1101U			UNITS
		MIN	TYP	MAX	
<b>AC PERFORMANCE</b>					
-3dB Bandwidth	$R_L = 15\Omega$ , $V_O = 1V_{p-p}$		24		MHz
	$R_L = 100\Omega$ , $V_O = 1V_{p-p}$		42		MHz
	$R_L = 15\Omega$ , $V_O = 6V_{p-p}$		17		MHz
	$R_L = 100\Omega$ , $V_O = 6V_{p-p}$		23		MHz
Slew Rate	$R_L = 100\Omega$ , $V_O = 6V_{p-p}$		100		V/ $\mu$ s
Step Response Delay <sup>(2)</sup>	$V_O = 1V_{p-p}$		25		ns
Settling Time to 1%, Step Input	$V_O = 1V_{p-p}$ , $R_L = 100\Omega$		0.12		$\mu$ s
Settling Time to 1%, Step Input	$V_O = 6V_{p-p}$ , $R_L = 100\Omega$		0.13		$\mu$ s
Settling Time to 0.1%, Step Input	$V_O = 1V_{p-p}$ , $R_L = 100\Omega$		0.30		$\mu$ s
Settling Time to 0.1%, Step Input	$V_O = 6V_{p-p}$ , $R_L = 100\Omega$		0.32		$\mu$ s
THD, Total Harmonic Distortion					
f = 10kHz	$R_L = 100\Omega$ , $V_O = 6V_{p-p}$		-88		dB
f = 10kHz	$R_L = 15\Omega$ , $V_O = 6V_{p-p}$		-85		dB
f = 100kHz	$R_L = 100\Omega$ , $V_O = 6V_{p-p}$		-83		dB
f = 100kHz	$R_L = 15\Omega$ , $V_O = 6V_{p-p}$	-66	-71		dB
Input Voltage Noise	f = 100kHz		30		nV/ $\sqrt{Hz}$
Input Current Noise	f = 100kHz		0.5		fA/ $\sqrt{Hz}$
<b>INPUT</b>					
Differential Input Resistance			$10^9$		$\Omega$
Differential Input Capacitance			1		pF
Common-Mode Input Resistance			$10^9$		$\Omega$
Common-Mode Input Capacitance			6		pF
Input Offset Voltage			3		mV
Input Bias Current			1		nA
Common-Mode Rejection Ratio	Input Referred		46		dB
Power Supply Rejection Ratio	Input Referred	55	76		dB
Input Common-Mode Voltage Range <sup>(4)</sup>		0.5		$V_{DD} - 0.5$	V
<b>OUTPUT</b>					
Differential Output Offset, RTO			$\pm 10$	$\pm 30$	mV
Differential Output Offset Drift, RTO	-40°C to +85°C		30		$\mu$ V/°C
Differential Output Resistance			0.16		$\Omega$
Peak Current (Continuous)	$R_L = 15\Omega$	200	230		mA
Differential Output Voltage Swing <sup>(5)</sup>	$R_L = 1k\Omega$		9.8		Vp-p
	$R_L = 100\Omega$	8.5	9.7		Vp-p
	$R_L = 15\Omega$		7.0		Vp-p
Gain	Fixed Gain, Differential		3.1		V/V
Gain Error				$\pm 0.25$	dB
<b>POWER SUPPLY</b>					
Operating Voltage Range	$V_{DD} = 5.0V$	4.5	5.0	5.5	V
Quiescent Current			25	38	mA
<b>TEMPERATURE RANGE</b>					
Thermal Resistance, $\theta_{JA}$		-40		+85	°C
8-Pin SOIC			125		°C/W

NOTES: (1) Measurement Bandwidth = 500kHz. (2) Time from 50% point of input step to 50% point of output step. (3) For step input. (4) Output common-mode voltage follows input common-mode voltage; therefore, if input  $V_{CM} = V_{DD}/2$ , then output  $V_{CM} = V_{DD}/2$ . (5) THD = 1%.

The information provided herein is believed to be reliable; however, BURR-BROWN assumes no responsibility for inaccuracies or omissions. BURR-BROWN assumes no responsibility for the use of this information, and all use of such information shall be entirely at the user's own risk. Prices and specifications are subject to change without notice. No patent rights or licenses to any of the circuits described herein are implied or granted to any third party. BURR-BROWN does not authorize or warrant any BURR-BROWN product for use in life support devices and/or systems.

## PIN CONFIGURATIONS

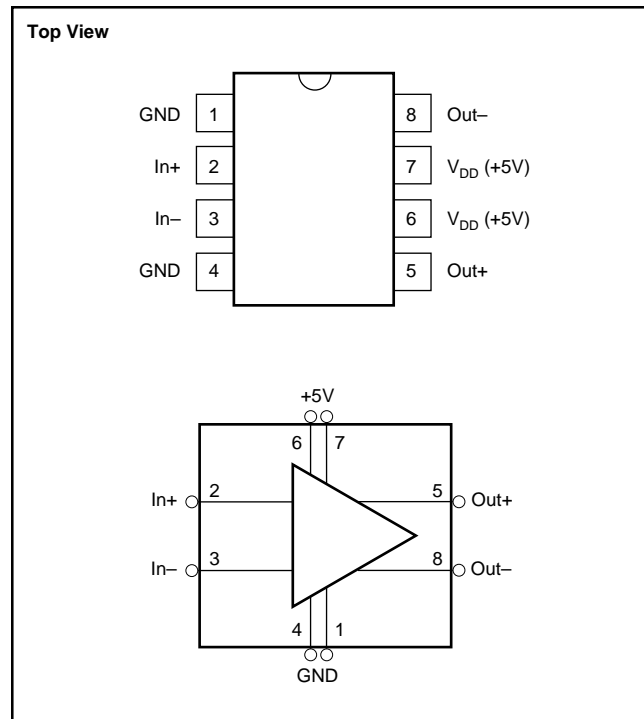

## ABSOLUTE MAXIMUM RATINGS

Analog Inputs: Current	$\pm 100\text{mA}$ , Momentary
	$\pm 10\text{mA}$ , Continuous
Voltage	GND $-0.3\text{V}$ to $V_{DD} + 0.2\text{V}$
Analog Outputs Short Circuit to Ground ( $+25^\circ\text{C}$ )	Momentary
Analog Outputs Short Circuit to $V_{DD}$ ( $+25^\circ\text{C}$ )	Momentary
$V_{DD}$ to GND	$-0.3\text{V}$ to $6\text{V}$
Junction Temperature	$+150^\circ\text{C}$
Storage Temperature Range	$-40^\circ\text{C}$ to $+125^\circ\text{C}$
Lead Temperature (soldering, 3s)	$+260^\circ\text{C}$
Power Dissipation	(See Thermal/Analysis Discussion)

## PACKAGE/ORDERING INFORMATION

PRODUCT	PACKAGE	PACKAGE DRAWING NUMBER <sup>(1)</sup>
DRV1101U	SO-8 Surface Mount	182

NOTE: (1) For detailed drawing and dimension table, please see end of data sheet, or Appendix C of Burr-Brown IC Data Book.

## ELECTROSTATIC DISCHARGE SENSITIVITY

This integrated circuit can be damaged by ESD. Burr-Brown recommends that all integrated circuits be handled with appropriate precautions. Failure to observe proper handling and installation procedures can cause damage.

ESD damage can range from subtle performance degradation to complete device failure. Precision integrated circuits may be more susceptible to damage because very small parametric changes could cause the device not to meet its published specifications.

# APPLICATIONS INFORMATION

## INTERNAL BLOCK DIAGRAM

The DRV1101 is a true differential input to differential output fixed gain amplifier. Operating on a single +5V power supply, it provides an internally fixed differential gain of +3V/V and a common-mode gain of +1V/V from the input to output. Fabricated on an advanced CMOS process, it offers very high input impedance along with a low impedance 230mA output drive. Figure 1 shows a simplified internal block diagram.

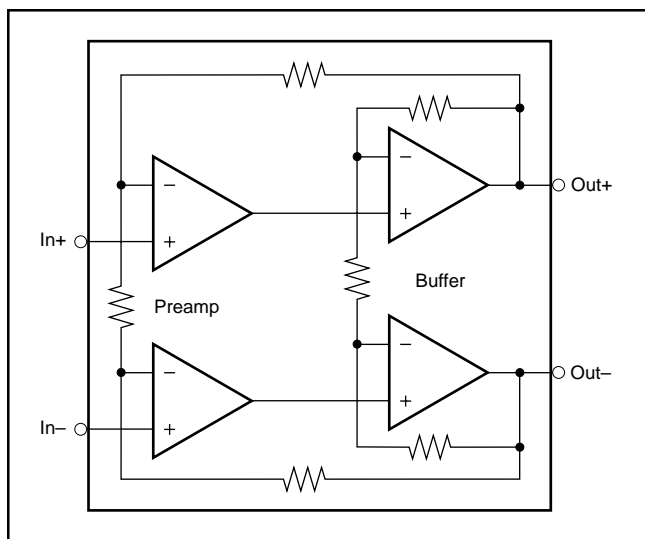

FIGURE 1. Simplified DRV1101 Internal Block Diagram.

The DRV1101 should be operated with the inputs centered at  $V_{DD}/2$ . This will place the output differential voltage centered at  $V_{DD}/2$  for maximum swing and lowest distortion. Purely differential input signals will produce a purely differential output signal. A single ended input signal, applied to one input of the DRV1101, with the other input at a fixed voltage, will produce both a differential and common-mode output signal. This is an acceptable mode of operation when the DRV1101 is driving an element with good common-mode rejection (such as a transformer).

## DIFFERENTIAL OUTPUT VOLTAGE AND POWER

Applying the balanced differential output voltage of the DRV1101 to a load between the outputs will produce a peak-to-peak voltage swing that is twice the swing of each individual output. This is illustrated in Figure 2 where the common-mode voltage is  $V_{DD}/2$ . For a load connected between the outputs, the only voltage that matters is the differential voltage between the two outputs—the common-mode voltage does not produce any load current in this case.

The peak power that the DRV1101 can deliver into a differential load is  $V_p^2/R_L$ . The peak voltage ( $V_p$ ) equals 1/2 of the peak-to-peak voltage ( $V_{p-p}$ ). Squaring 1/2 of the  $V_{p-p}$  and dividing by the load impedance will give the peak power. For

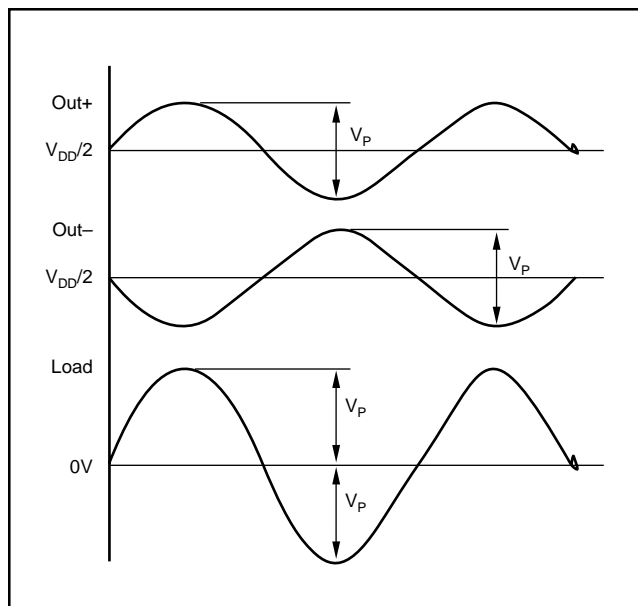

FIGURE 2. DRV1101 Single Ended and Differential Output Waveforms.

example, the specifications show that on +5V supply the DRV1101 will deliver 6.0Vp-p into 15Ω. The peak load power under this condition is  $(6.0V_{p-p}/2)^2/15\Omega = 600mW$ .

## POWER SUPPLY

The DRV1101 is designed for operation on a single +5V supply. For loads  $> 200\Omega$ , each output will swing rail to rail. This gives a peak-to-peak differential output swing that is approximately  $= 2 \cdot V_{DD}$ . For best distortion performance, the power supply should be decoupled to a good ground plane immediately adjacent to the package with a 0.1μF capacitor. In addition, a larger electrolytic supply decoupling capacitor (6.8μF) should be near the package but can be shared among multiple devices.

## DIGITAL SUBSCRIBER LINE APPLICATIONS

The DRV1101 is designed for the high power, low distortion, requirements of a twisted pair driver in digital communications applications. These include ADSL (Asymmetrical Digital Subscriber Lines), and RADSL (Rate adaptive ADSL). Figure 3 shows a typical transformer coupled xDSL line driver configuration.

The DRV1101 is recommended as the upstream driver (CPE equipment) for ADSL G.Lite systems. These system require an rms line power of 10dBm with a voltage crest factor of 5.3 (crest factor is the ratio of peak to rms voltage). A voltage crest factor of 5.3 is equivalent to a power crest factor of about 15dB. Therefore, the peak power required at the line for G.Lite is 25dBm. Using the basic circuit shown in Figure 3, DRV1101 will provide this power to the line with very low distortion.

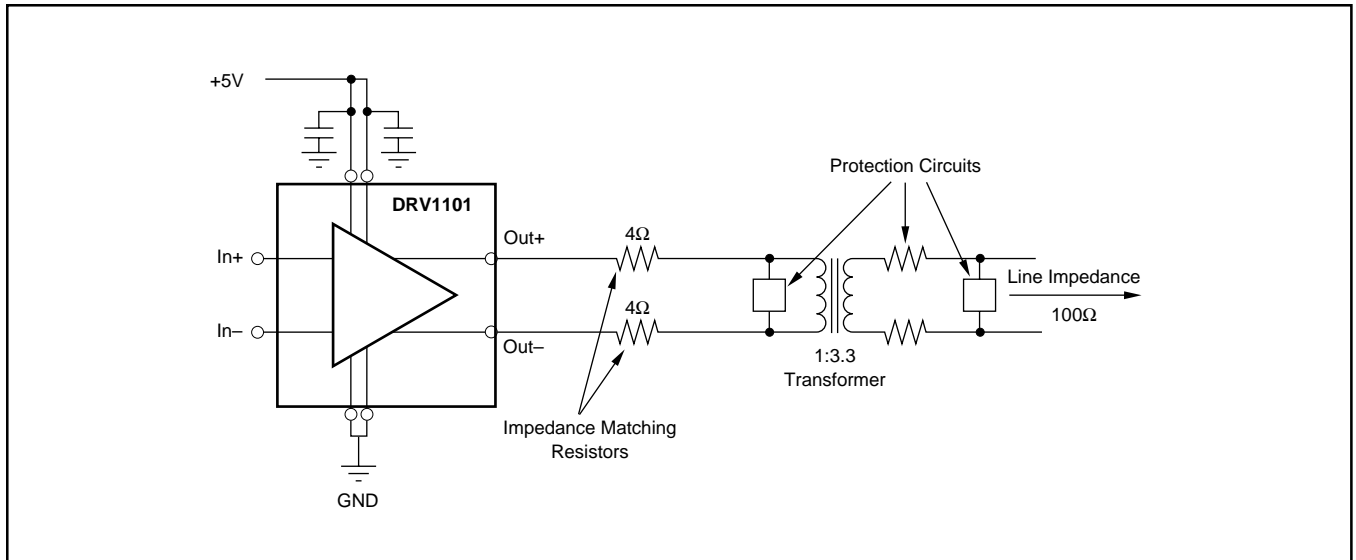

FIGURE 3. Typical Digital Subscriber Line Application.

To calculate the amplifier requirements for a DSL application:

1. Determine the average power that must be delivered to the line. The amplifier must deliver twice this power to account for the power dissipated in the series impedance matching resistors. Therefore, add 3dB to the line power. This is the average power delivered at the output of the amplifier. For ADSL G.Lite (as of June 1998), the average line power is 10dBm. Adding 3dB results in an average power at the amplifier output of 13dBm.
2. Next add the power crest factor needed for the line code used. The power crest factor for ADSL is 15dB which means that the peak power ( $P_{PEAK}$ ) needed at the amplifier output is 28dBm (13dBm + 15dB). 28dBm is 631mW.
3. The DRV1101 peak output voltage is calculated by the formula:  $V_{PEAK} = (P_{PEAK} \cdot R_L)^{1/2}$  where  $R_L$  is the load impedance that the DRV1101 must drive. For ADSL Lite, using the circuit shown in Figure 3,  $V_{PEAK} = (P_{PEAK} \cdot R_L)^{1/2} = (.631W \times 17\Omega)^{1/2} = 3.3V$ . The peak-to-peak voltage out of the DRV1101 is  $2 \times 3.3V = 6.6V$ .
4. The transformer turns ratio can be changed to keep the required output voltage and current within the range of the DRV1101. The line impedance ( $R_{LINE}$ ) is 100Ω for ADSL. The impedance that is reflected to the DRV1101 side of the transformer is  $R_{LINE}/(\text{turns ratio})^2$ . For best power transfer, the total of the impedance matching resistors should equal the reflected impedance. Thus, for the circuit shown in Figure 3, the reflected impedance is  $100\Omega/(3.4)^2 = 8.6\Omega$ . With two impedance matching resistors of 4Ω each and about 0.5Ω transformer resistance, the total load impedance is about  $(8.6\Omega + 4\Omega + 4\Omega + 0.5\Omega) = 17\Omega$ .

## OUTPUT PROTECTION

Figure 3 also shows overvoltage and short circuit protection elements that are commonly included in DSL applications. Overvoltage suppressors include diodes or MOV's. The outputs of the DRV1101 can be momentarily shorted to ground or to the supply without damage. The outputs are not, however, designed for a continuous short to ground or the supply.

## POWER DISSIPATION AND THERMAL ANALYSIS

The total internal power dissipation of the DRV1101 is the sum of a fixed overhead power that is independent of the load plus the power dissipated internally to deliver the average load power. The total internal power dissipation determines the internal temperature rise when in operation. For DSL applications with high crest factors, such as ADSL, the average load power delivered is much lower than the peak power required. For practical purposes, this means that internal temperature rise is not an issue for the DRV1101 in high-crest factor DSL applications.

With a +5V supply, the DRV1101's typical fixed overhead current of 22mA (out of total no-load supply current of 29mA) creates a fixed overhead power dissipation of 110mW. The load dependent power dissipation of the DRV1101 when delivering an output voltage  $V_{rms}$  to a load  $R_L$  is:

$$P = (V_{DD} - V_{rms}) \cdot (V_{rms}/R_L)$$

The internal power dissipation will reach a maximum when  $V_{rms}$  is equal to  $V_{DD}/2$ . For a sinusoidal output, this corresponds to an output  $V_{p-p} = 1.41 \cdot V_{DD}$ .

As an example, compute the power and junction temperature under a worst case condition with  $V_{DD} = +5V$  and  $V_{rms} = 2.5V$  into a 20Ω differential load. The total internal power dissipation would be:

$$\underbrace{(110mW)}_{\text{Fixed}} + \underbrace{(5V - 2.5V) \cdot (2.5V/20\Omega)}_{\text{Load Related}} = 423mW$$

To compute the internal junction temperature, this power is multiplied by the junction to ambient thermal impedance (to get the temperature rise above ambient) then added to the ambient temperature. Using the specified maximum ambient temperature of +85°C, the junction temperature for the DRV1101 in an SO-8 package under these worst case conditions will be:

$$T_j = 85^\circ\text{C} + 0.423\text{W} \cdot 125^\circ\text{C}/\text{W} = 138^\circ\text{C}$$

The internal junction temperature should, in all cases, be limited to < 150°C. For a maximum ambient temperature of +85°C, this limits the internal temperature rise to less than 65°C. Figure 4 shows the temperature rise from ambient to junction for loads of 15Ω and 100Ω.

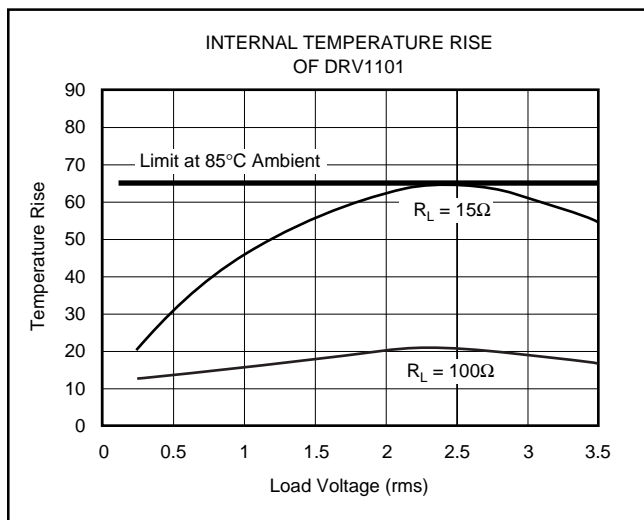

FIGURE 4. Junction Temperature Rise From Ambient for the DRV1101U.

## INPUT INTERFACE CIRCUITS

DRV1101 is designed for operation with a differential input centered at  $V_{DD}/2$ . Signals that do not require DC coupling may be connected as shown in Figure 5 through blocking caps to a midpoint reference developed through resistor dividers from the supply voltage. The 1MΩ bias resistors determine four performance requirements.

- They bias the inputs at the supply midpoint.
- They provide a DC bias current path for the input of the DRV1101.
- They set the AC input impedance of the circuit to approximately 1MΩ.
- They set the low cutoff frequency along with  $C_B$ .

The bias resistors may be set to a lower level if a lower input impedance is desired.

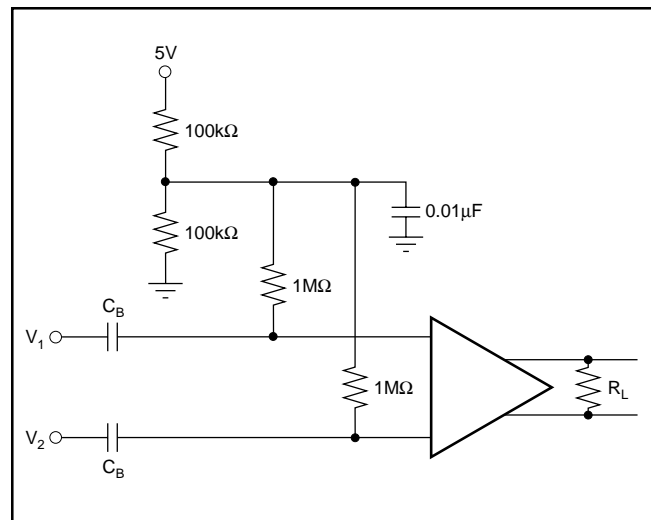

FIGURE 5. AC-Coupled Differential Input Interface.