

Li/LiPo Charger and Power Selector

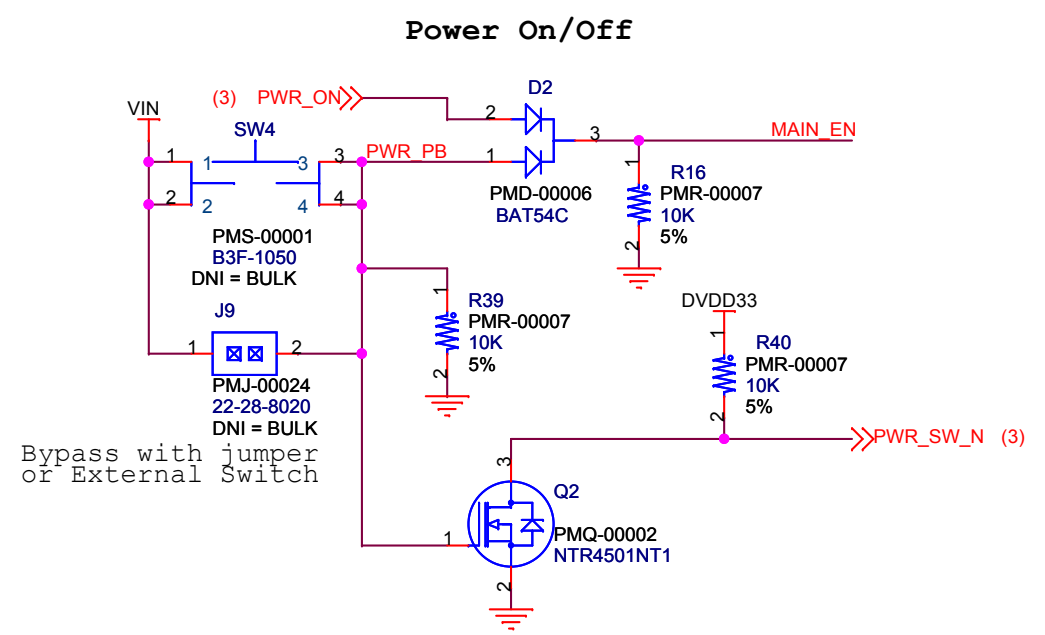

Power On/Off

Remove two R6/R7 to use NGW100 power entry for VCC5
!USE WITH GREAT CARE!

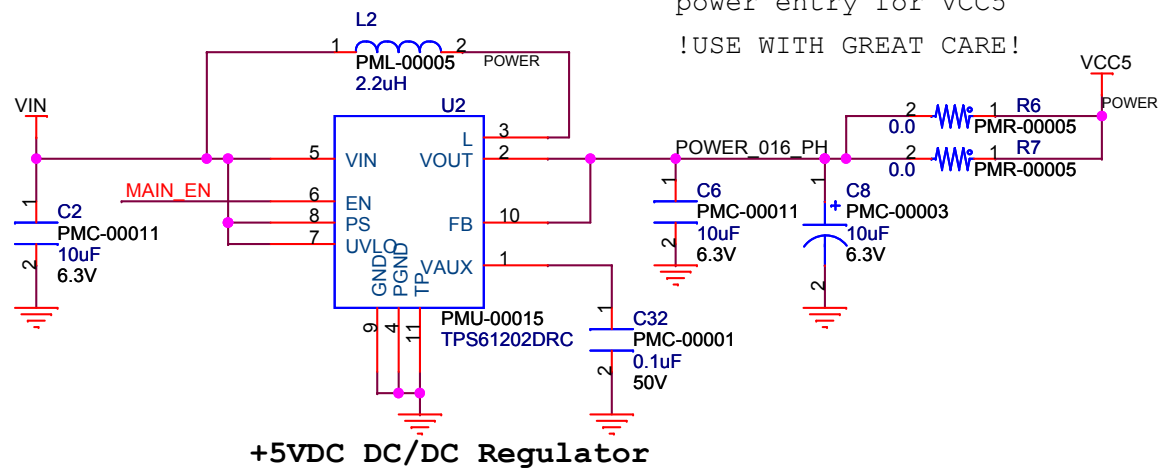

+5VDC DC/DC Regulator

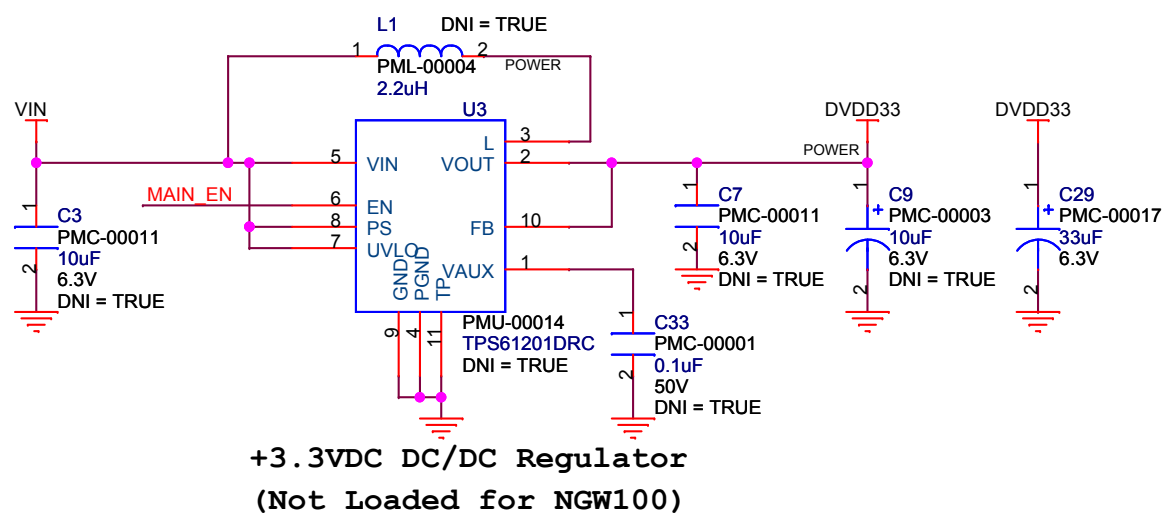

+3.3VDC DC/DC Regulator
(Not Loaded for NGW100)

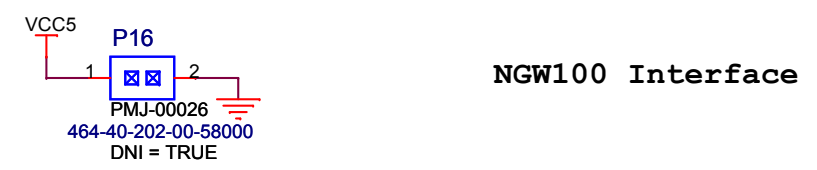
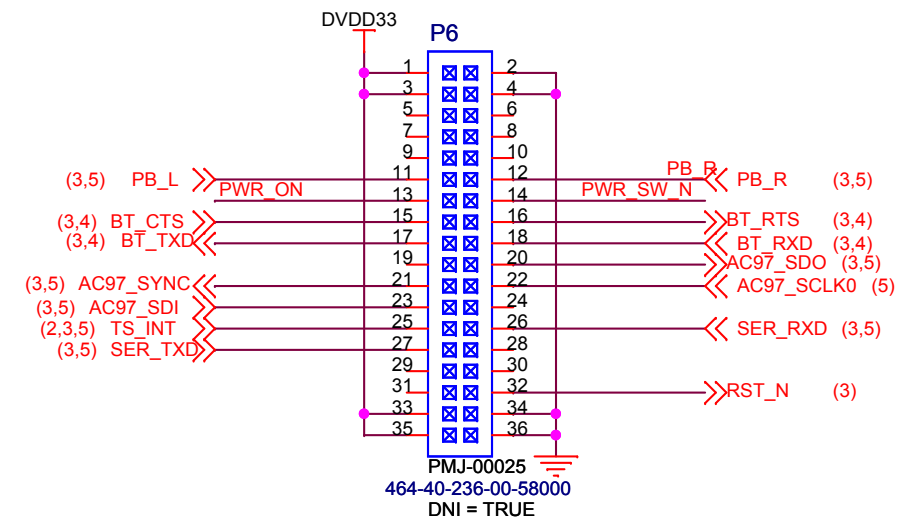
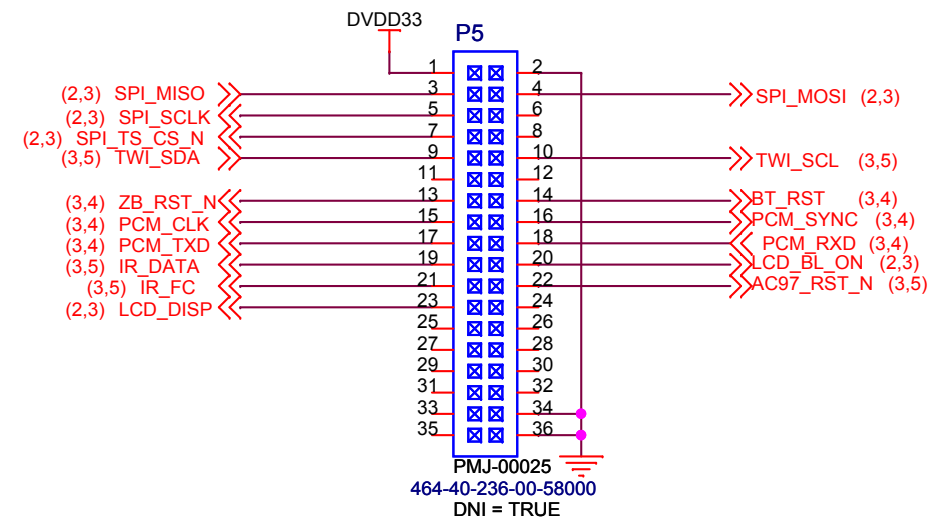

NGW100 Interface

Special Notes:
1) "DNI" Property on components:
TRUE: do not purchase and do not load
BULK: purchase but do not load
<blank>: purchase and load

Copyright 2008 Mediama Technologies Burnaby, British Columbia, Canada		www.mediamatech.com	
Power Input/Charger, NGW100 Interface			
Title Remote Media Terminal 1 (NGW100 Daughter Card)			
Size B	Document Number SCH-RMT1	Rev 1.3	
Date:	Tuesday, July 29, 2008	Sheet	1 of 5

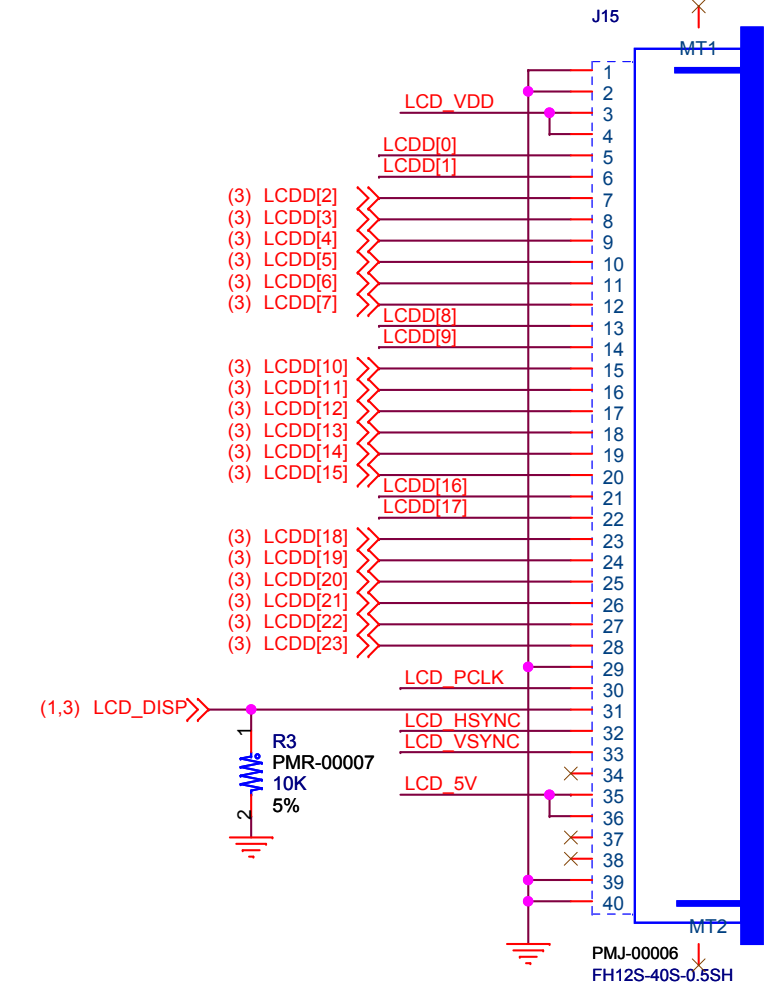
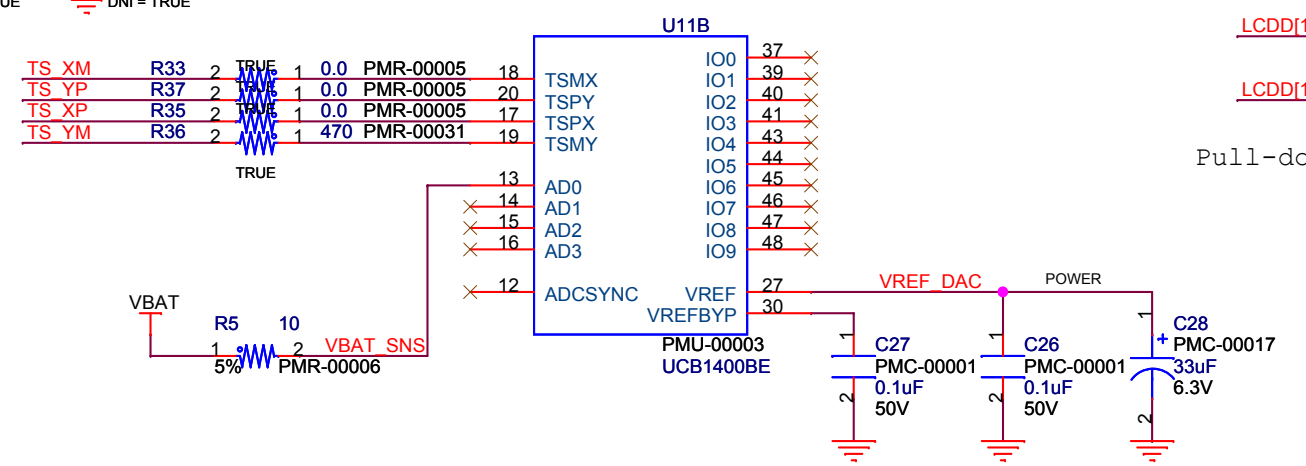
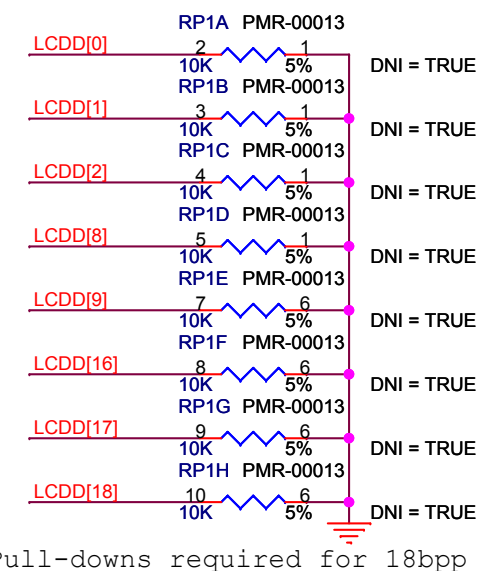
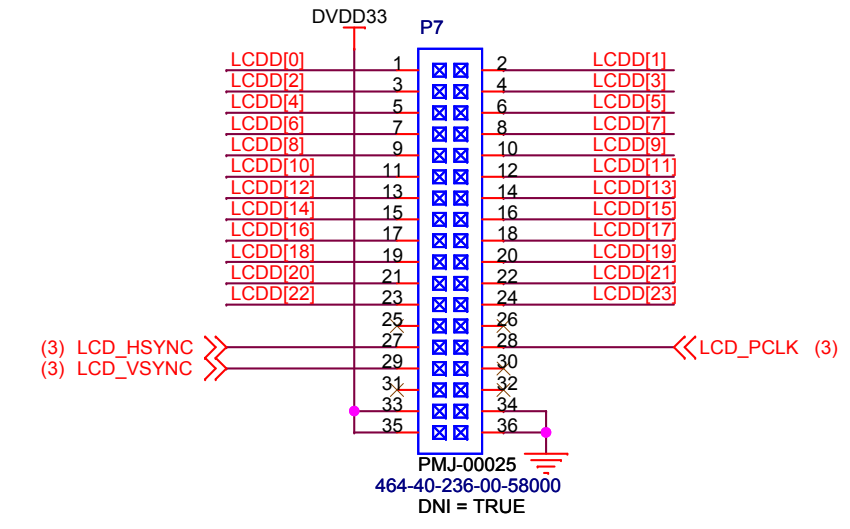
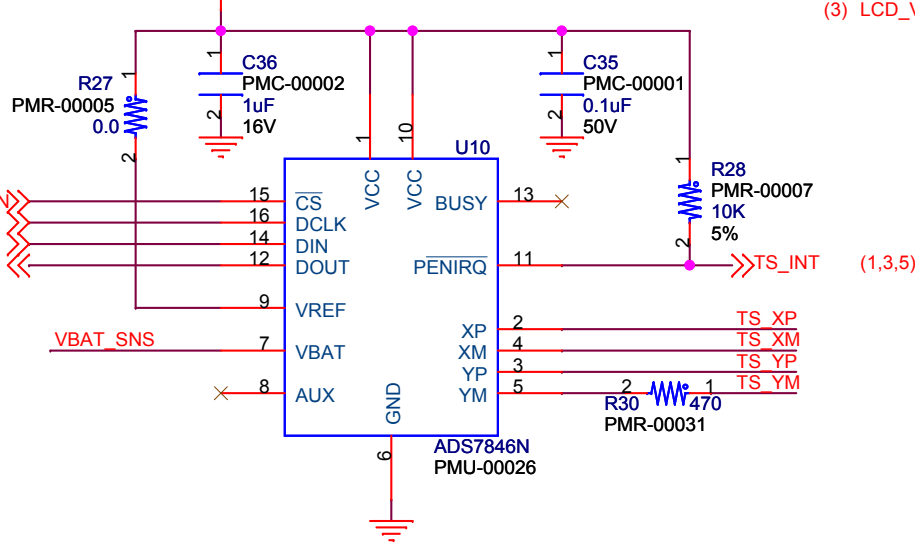
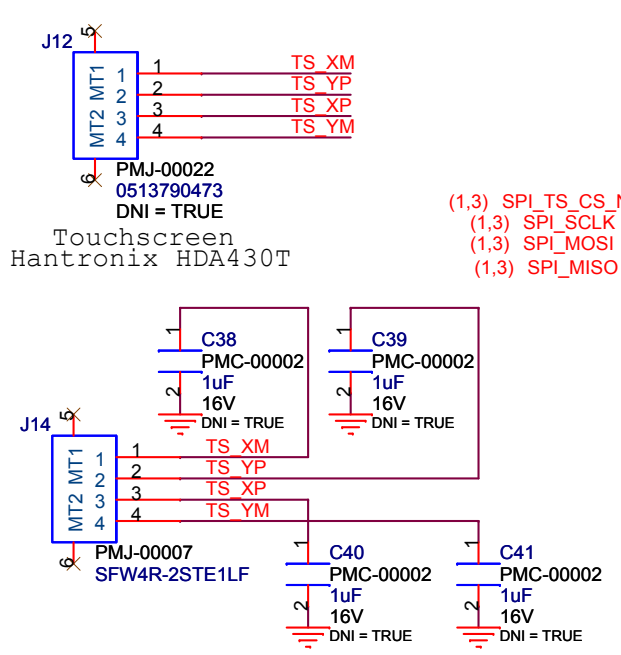
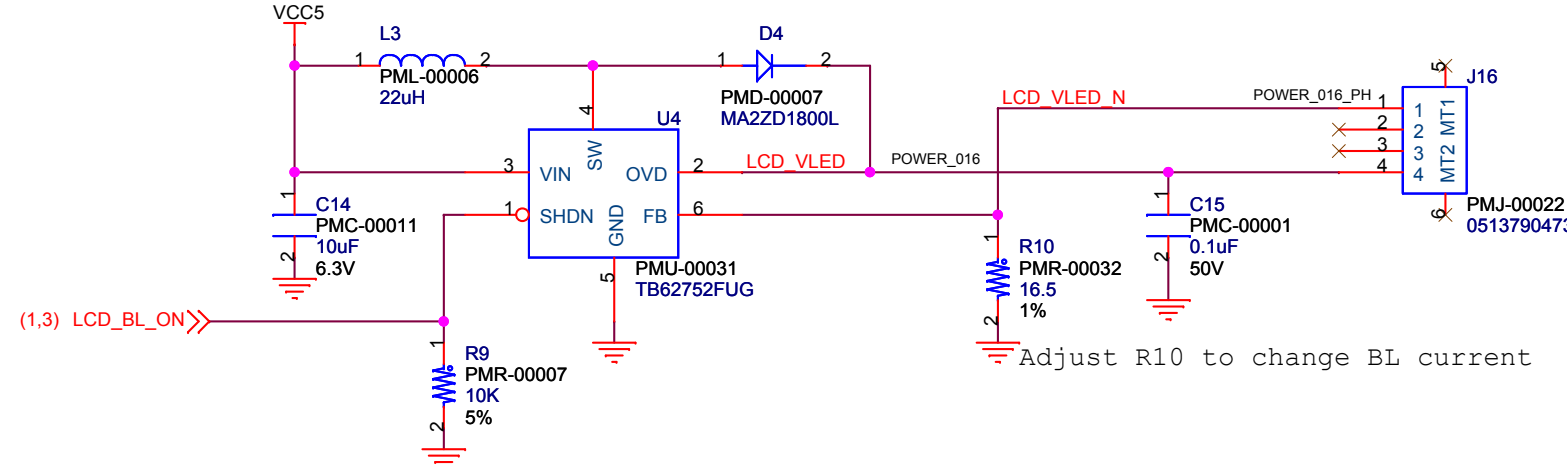
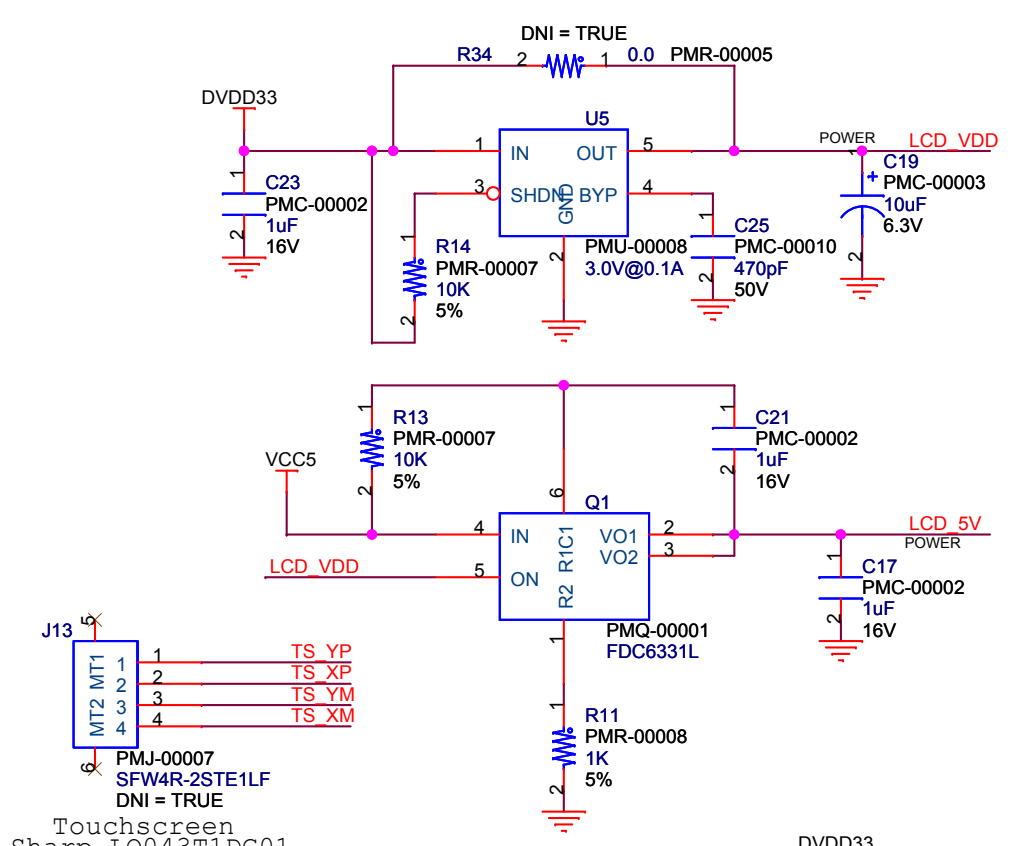

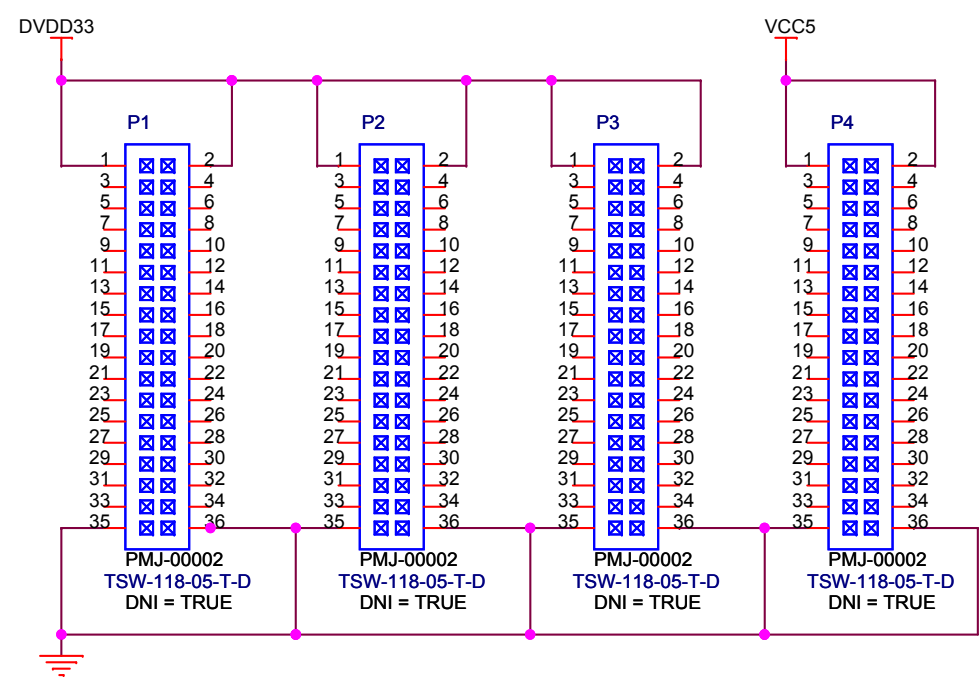
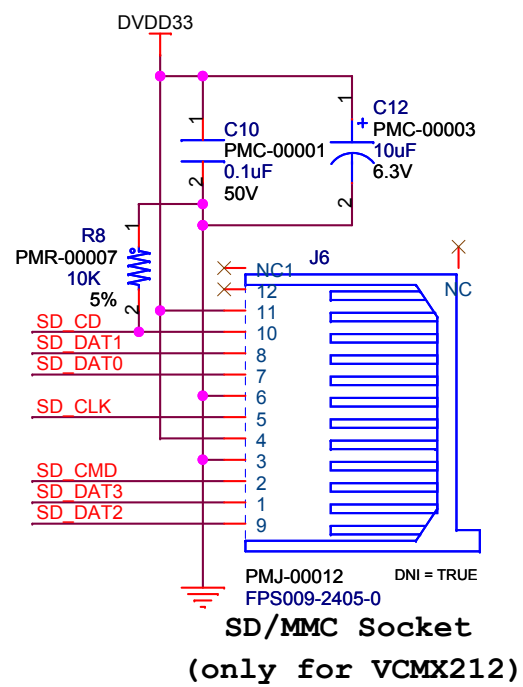
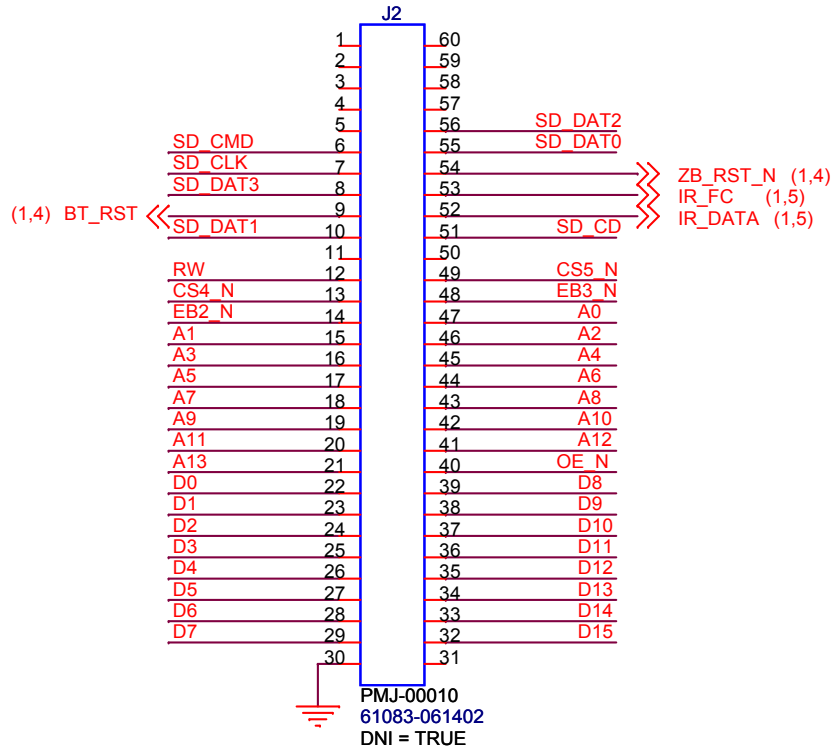
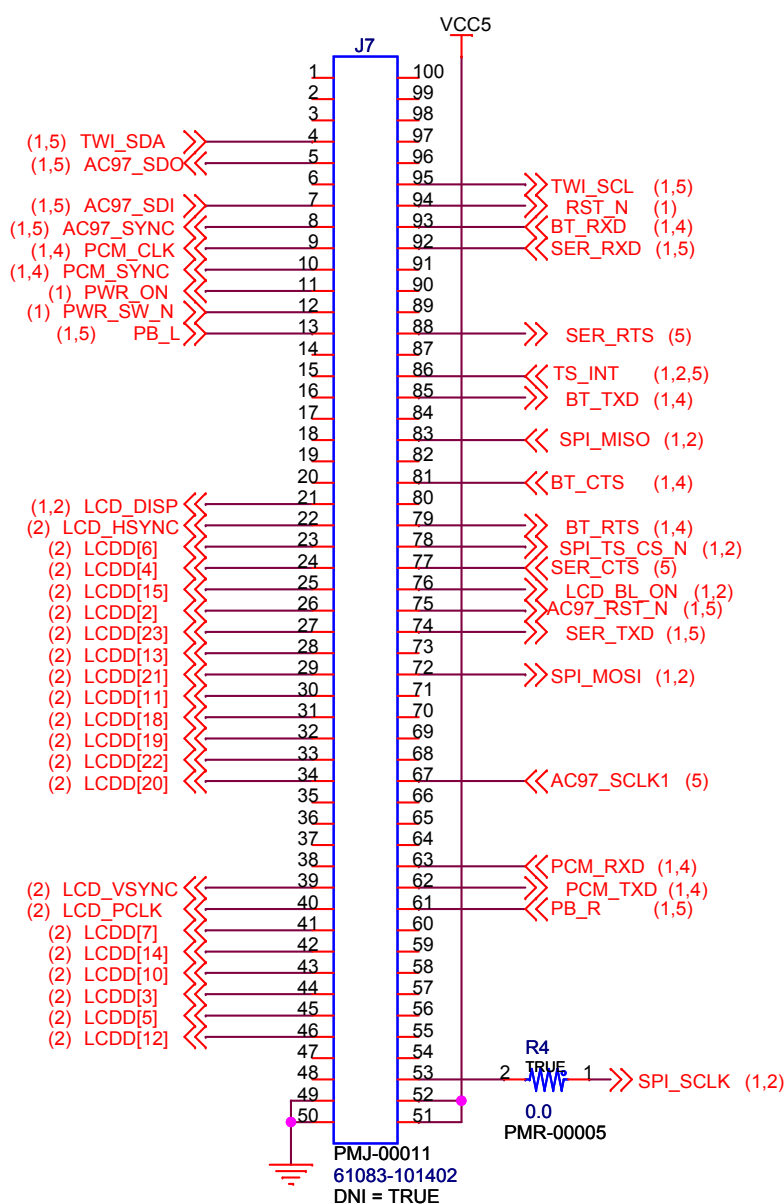

Copyright 2008 Mediama Technologies Burnaby, British Columbia, Canada		www.mediamatech.com	
VCMX212 Support & Prototyping			
Title Remote Media Terminal 1			
Size B	Document Number SCH-RMT1	Rev 1.3	
Date:	Tuesday, July 29, 2008	Sheet	3 of 5

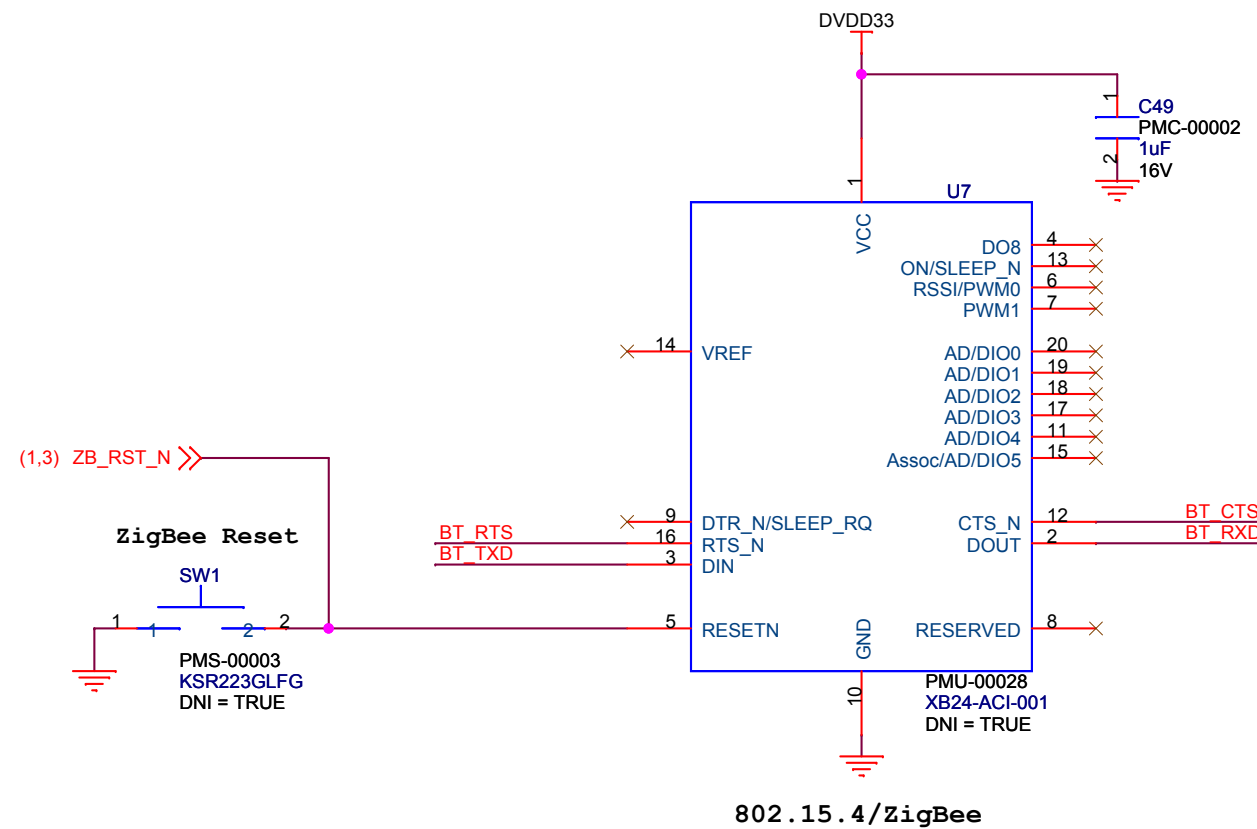
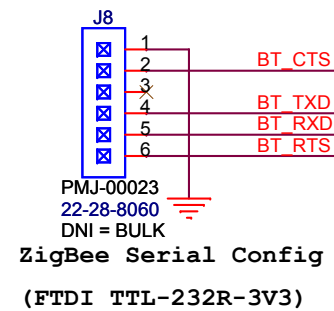
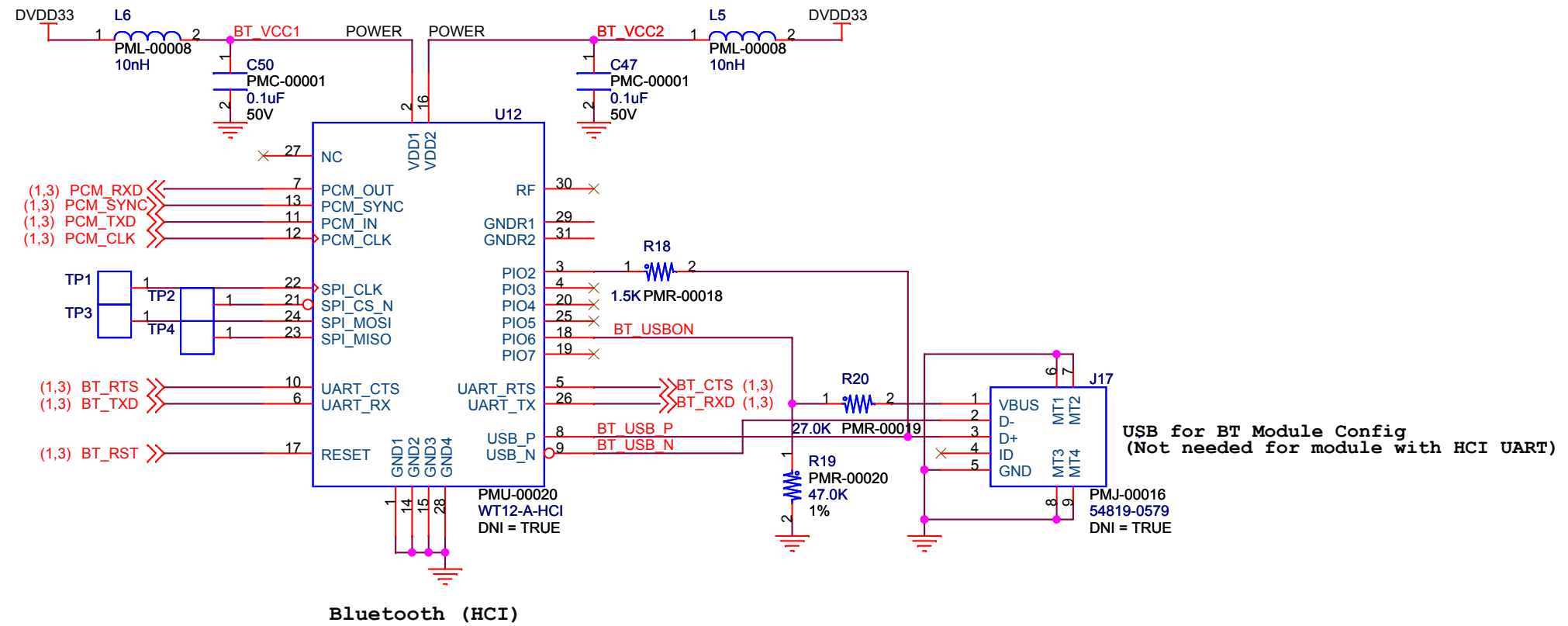

Copyright 2008 Mediama Technologies Burnaby, British Columbia, Canada		www.mediamatech.com	
Wireless Options			
Title Remote Media Terminal 1			
Size B	Document Number SCH-RMT1	Rev 1.3	
Date:	Tuesday, July 29, 2008	Sheet	4 of 5

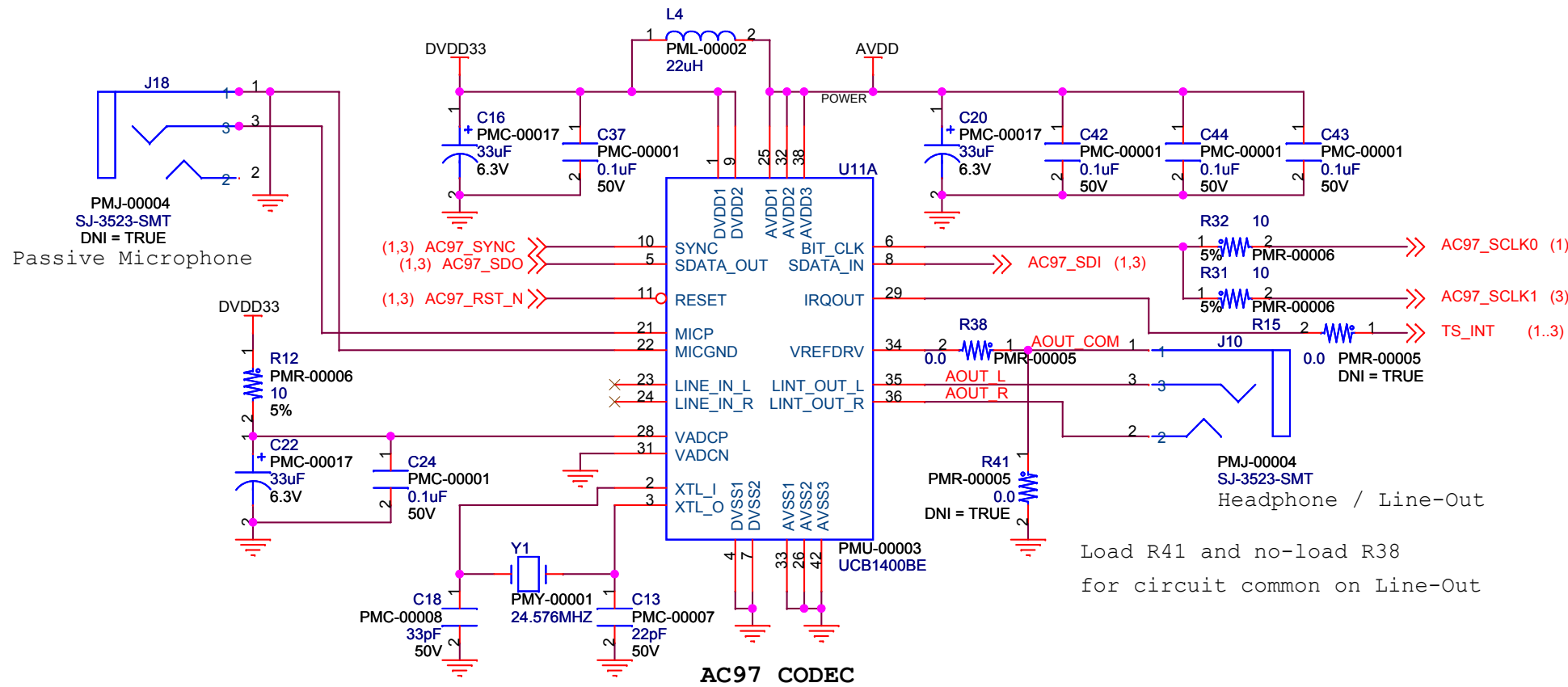
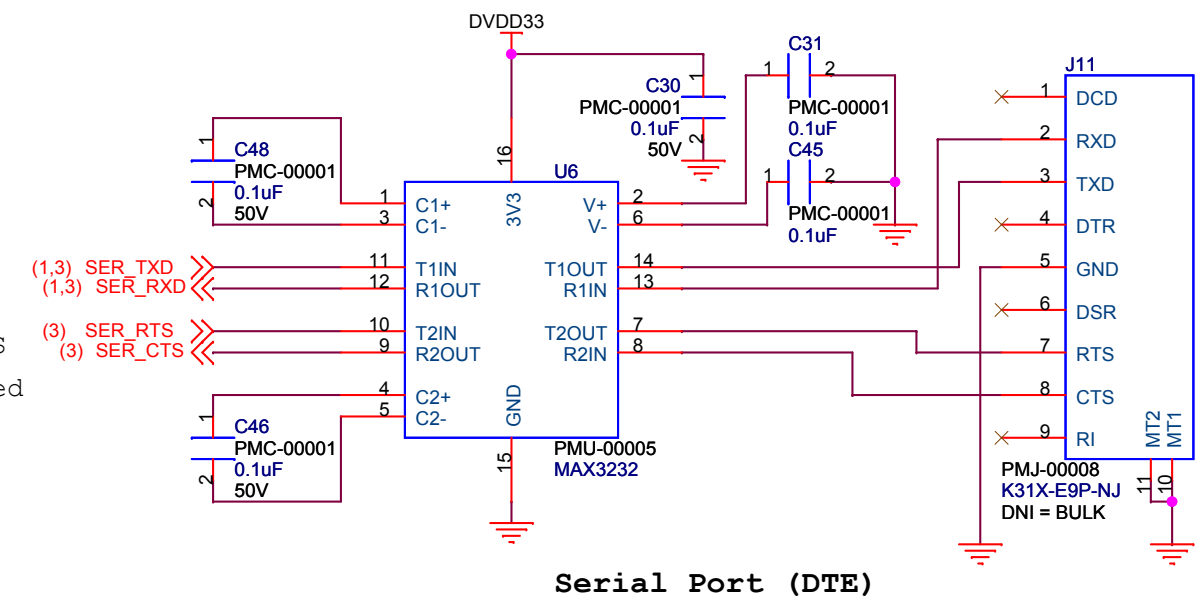
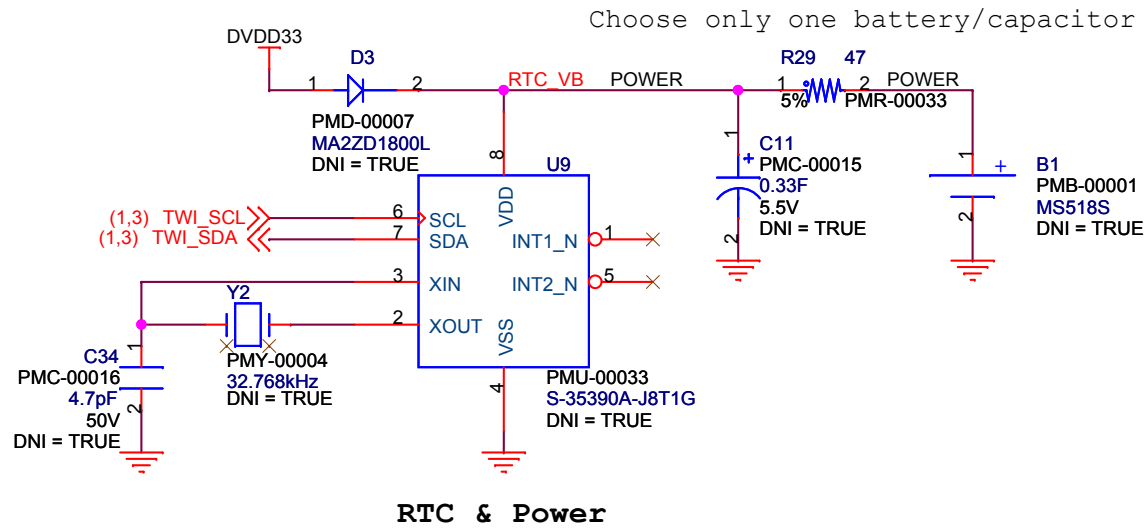
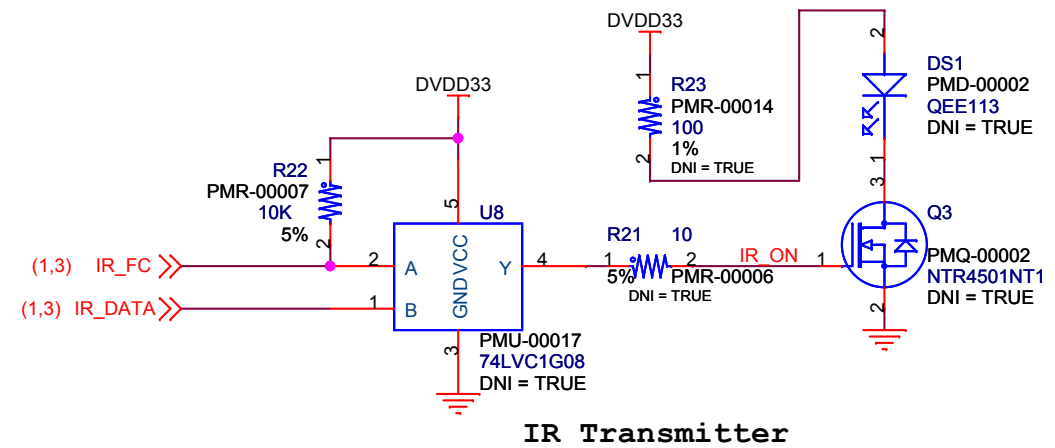
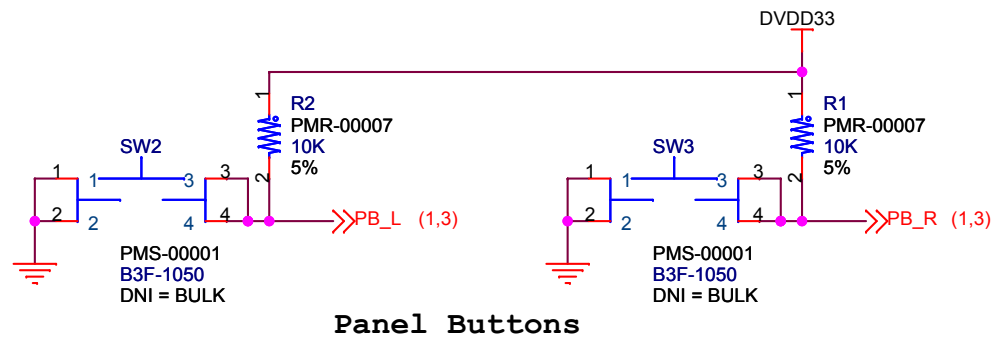

Copyright 2008 Mediama Technologies Burnaby, British Columbia, Canada		www.mediamatech.com	
Peripherals			
Title Remote Media Terminal 1			
Size B	Document Number SCH-RMT1	Rev 1.3	
Date:	Tuesday, July 29, 2008	Sheet	5 of 5